

**TECHNICAL SPECIFICATION
LOAD BREAK SWITCHES**

**TECHNICAL SPECIFICATION
LOAD BREAK SWITCHES**

TYPE LDTP

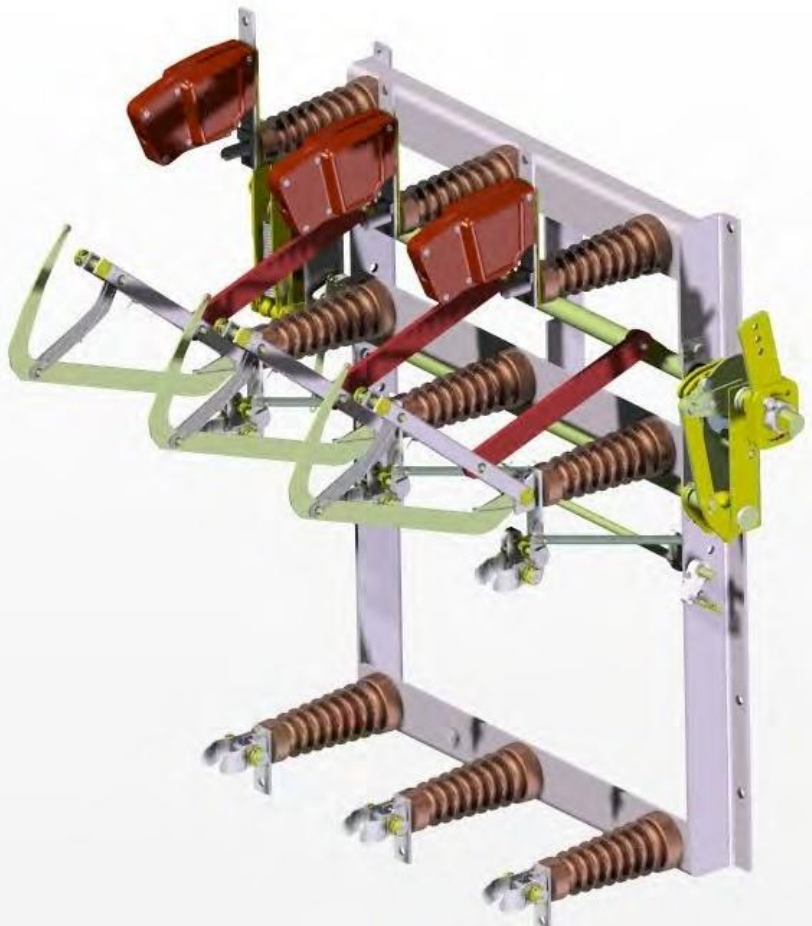

WITH FUSE HOLDER

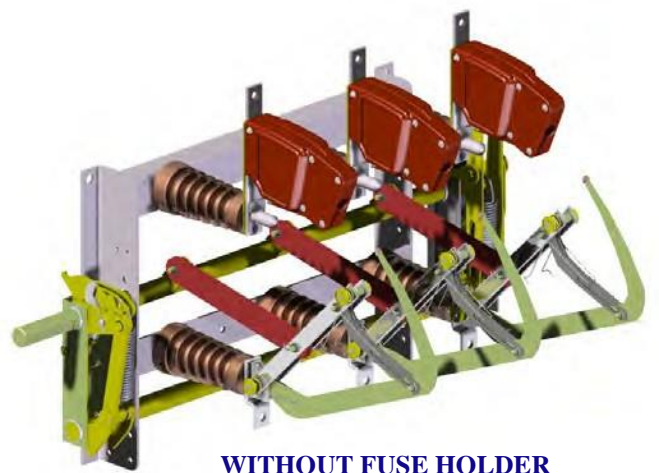

WITHOUT FUSE HOLDER

TECHNICAL SPECIFICATION LOAD BREAK SWITCHES

Contents

	PAGE
1 General Features	3
2 Standards	3
3 Service Conditions	4
4 Electrical Capacities	4
5 Construction	5
6 Selection Chart	6
7 Dimensions	7
8 Technical Information	7
9 Tests	7
10 Marking	7
12 Accessories and Spare Parts	8

TECHNICAL SPECIFICATION

LOAD BREAK SWITCHES

1. General Features

Load break switches DRIWISA® are used in medium voltage systems from 7.2 kV up to 38 kV. Installed inside the metal enclosed substations or medium voltage metal enclosed switchgear for indoor or outdoor service.

Applications

- Sectionalize and isolate lines or cables, metal enclosed substations, bars and the power supply.
- Sectionalize and isolate ring networks.
- Connect or disconnect transformers.

Characteristics

- Opening and closing operation in tripolar group.
- Quick main and quick break mechanism, without depending the operator ability.
- Fuse operation (load break disconnecter switches with fuse holder).

Advantages

- Easy installation.
- Vertical, horizontal or inverted mounting.
- Safe and simple operation.
- Minimum maintenance.

2. Standards

Load break switches DRIWISA® comply with the following standards:

NMX-J-098	Sistemas eléctricos de potencia-suministro-tensiones eléctricas normalizadas.
NMX-J-564	Equipos de desconexión y su control - parte 1: especificaciones comunes.
NMX-J-323	Cuchillas seccionadoras de operación con carga para media tensión - especificaciones y métodos de prueba.
NMX-J-068	Tableros de alta tensión.
IEC 62271-1	Common specifications.
IEC 62271-103	Switches for rated voltages above 1 kv and less than 52 kv.
IEC 62271-200	Ac metal-enclosed switchgear and control gear for rated voltages above 1 kV and up to and including 52 kV.
IEC 60273	Characteristics of indoor and outdoor post insulators for systems with nominal voltages greater than 1000 v.
IEC-60282-1	High voltage fuses – Part 1: Current-limiting fuses.
ANSI-IEEE STD C37.20.3	Standard for metal-enclosed interrupter switchgear.
ANSI C37.22	Preferred ratings and related required capabilities for indoor ac medium-voltage switches used in metal-enclosed switchgear.
IEEE STD C37.20.4-2001	Standard for indoor ac switches (1 kV–38 kV) for use in metal-enclosed switchgear.

TECHNICAL SPECIFICATION LOAD BREAK SWITCHES

3. Service Conditions

Load break switches DRIWISA® are able to operate within the range of the following environment conditions:

Temperature: -10 °C / +40 °C.
 Relative Humidity: < 60%
 Altitude: 0 - 1000 msnm *

* For higher installation heights must apply the appropriate correction factor (IEC 60694)

The enclosure, metal enclosure substation or board, must have the appropriate NEMA or IP degree protection to secure the specified temperature or humidity conditions and keep the inside air free of smoke, gases, water, corrosive or explosive steamers and electrically conductive particles (dust).

IEC 60529 Degrees of protection provided by enclosures (IP Code).

NEMA 250 Enclosures for electrical equipment (1000 volts maximum).

4. Electrical Capacities

Load break switches DRIWISA® comply with the following electrical values (according to the requirements of Section 2 Standards):

Series	Maximum Voltage kV	Rated Current A	Rated Peak Current kA	Rated Short Circuit Current kA (rms) @ 3 seg	Rated Withstand Voltage Impulse (BIL) 1.2 X 50µs kV	Rated Withstand Voltage 60Hz DRY 1 min kV
07	7.2	400	65	25	60	20
		630	65	25	60	20
		1250	99	38.1	60	20
15	17.5	400	65	25	95	38
		630	65	25	95	38
		1250	99	38.1	95	38
20	25.8	400	65	25	125	60
		630	65	25	125	60
		1250	99	38.1	125	60
30	38	400	65	25	150	80
		630	65	25	150	80
		1250	99	38.1	150	80

4.1. Rated operating capacities:

Maximum switching current load:	In (rated current with a FP > 0.7).
Mechanical life:	1,000 non load operations
Electrical life:	40 operations at the maximum interrupting current

TECHNICAL SPECIFICATION

LOAD BREAK SWITCHES

5. Construction

Load break disconnecter switches on air DRIWISA® are mainly constructed with the following elements:

5.1. Base frame

A steel frame made of angles and canals with an electrolytic galvanized corrosion coating with a 18 µm thickness, able to support mechanical efforts resulting of the normal operation and the effects of short circuit currents.

5.2. Insulators

Non-hygroscopic and non-flammable material with the mechanical strength to support the efforts generated of the normal operation and the effects of short circuit currents. Its mechanical strength does not allow deformations that cause insulation failures in the non-load isolator switches.

5.3. Arc extinguishing system

It is constructed of insulating material to extinguish the maximum interrupting current and support the electrical life established in section 4.1.

5.4. Conductive parts

Are made of electrolytic copper (99.9%) with round edges, plated with 5 µm, able to support short-term currents and stand up to the limits of temperature increase according to the standards in Section 2.

5.5. - Quick main and quick break mechanisms

A solid steel bar with anticorrosive electroplated zinc coating with 18 µm thickness. The strength of the materials used guarantees the mechanical operations indicated in the Section 4.1.

5.6. Mechanism axis (Drive shaft)

A solid steel bar with anticorrosive electroplated zinc coating with 18 µm thickness, able to support mechanical strength efforts generated of the normal operation and the effects of short circuit currents.

5.7. Fuse clip holder (only in load break disconnecter switch with fuse holder)

Are made of electrolytic copper (99.9%), plated with 5 µm, contact area with the fuse more than 80%. The contacts are designed to receive DRIWISA® current limiting fuses (IEC 60282-1) for a 45 mm diameter contact area.

5.8. Transmission set and tripping system for 3 poles (only in load break switch with fuse holder)

Material designed for temperature rises, this ensures that can work with conductive parts or be in contact with steel parts as is indicated in NMX-J-323 standard. The designed admit DRIWISA current limiting fuses with striker pin (120 N).

5.9. Fuse Holder (only in load break switch with fuse holder)

DRIWISA fuse holder design admits the installation of DRIWISA current limiting fuses indicated i NMX-J- 149/1 and IEC 60282-1 standards and complain with the following dimensions.

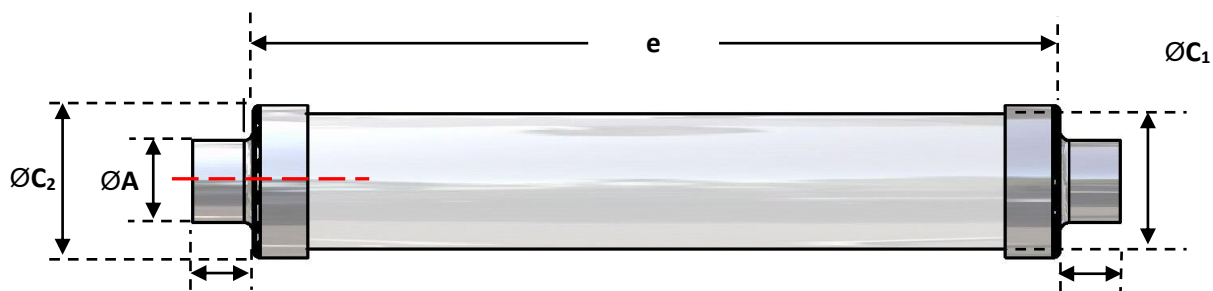

TECHNICAL SPECIFICATION LOAD BREAK SWITCHES

Note: Striker pin is situated at the middle line of the fuse.

$\varnothing A$	B	$\varnothing C_2$ (minimum)	$\varnothing C_{1y} \varnothing C_2$ (maximum)	e
45	33	50	88	192
				292
				442
				537

6. Selection Chart

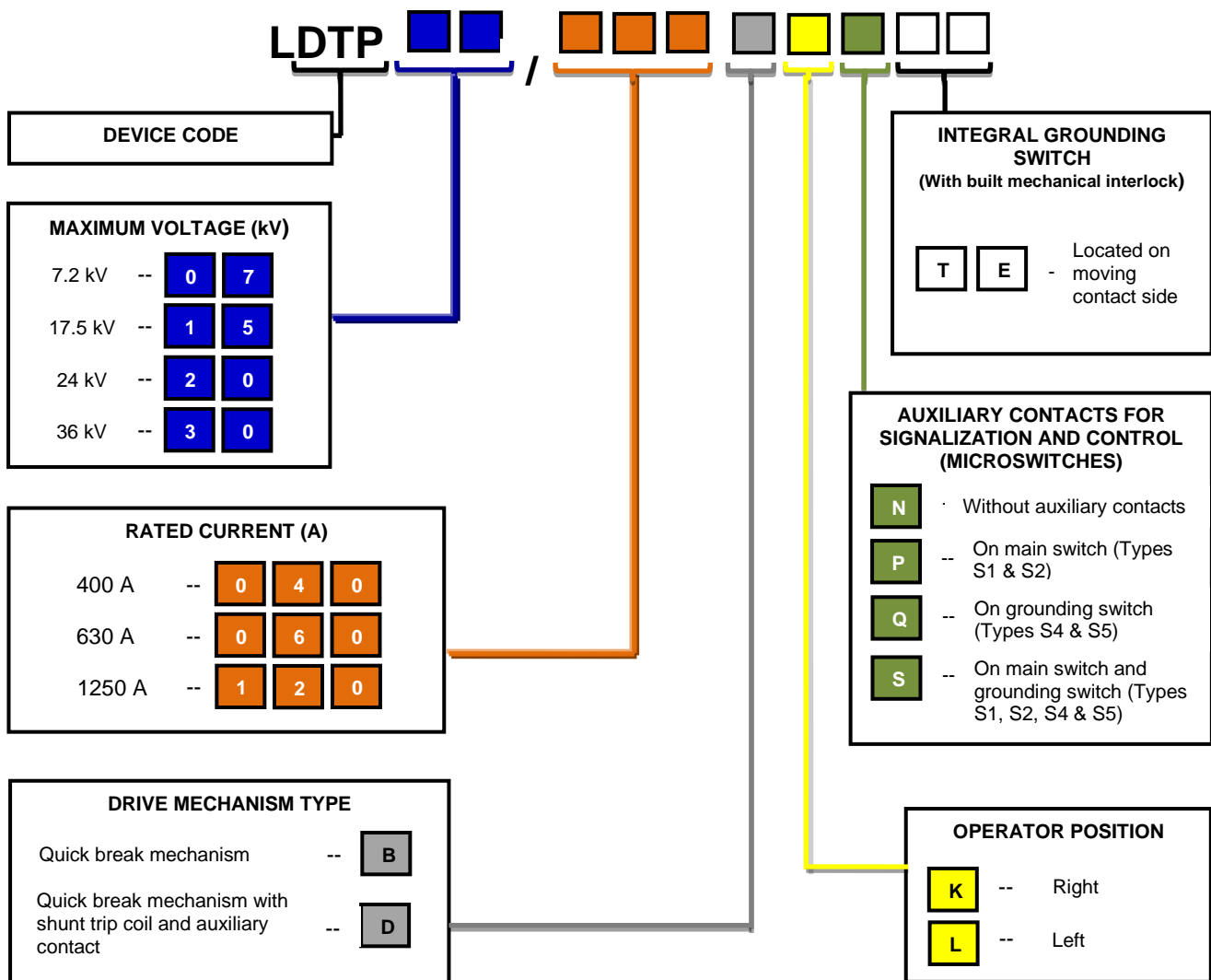

* The operator position refers to the normal mounting position as shown in Figure 1.

TECHNICAL SPECIFICATION LOAD BREAK SWITCHES

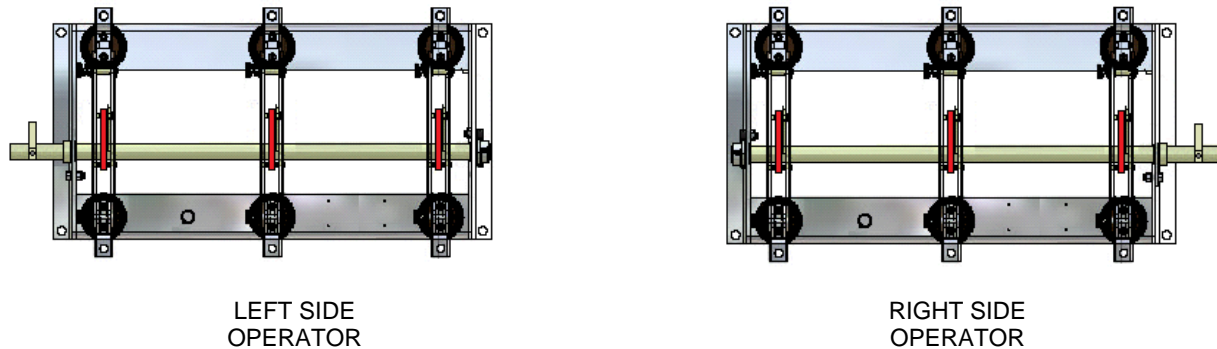

Figure 1

7. Dimensions

The dimensions of load break switches depend on the capacity that is required.

8. Technical Information

8.1. Drawings

Printed drawings are provided as required in letter size, multiple letter size or electronic format (2D or 3D).

8.2. User manuals

Easily accessed on our website <http://www.driwisa.com/manuales>

9. Tests

9.1. Prototype test reports

We provide reports of prototype tests performed in accredited national laboratories (LAPEM) that guarantee the fulfillment of the values and capacities specified in Section 4 Electrical Capacities.

9.2. Routine tests

Routine tests are done to each load break switches DRIWISA®. The routine tests are the following:

- Visual inspection.
- Dimensional analysis.
- Contact resistance.
- Voltage withstands 60 Hz.
- 10 non load mechanical operations.

10. Marking

Load break switches DRIWISA® contain a nameplate made of stainless-steel material and has recorded the following data:

- Name of the manufacturer.
- Serial number.
- Type and model.
- Nominal voltage kV.

TECHNICAL SPECIFICATION LOAD BREAK SWITCHES

- Rated withstand voltage impulse in kV.
- Rated current A.
- Rated short circuit current in kA.
- Rated short circuit current time (1 s or 3 s).
- Legend "Made in Mexico".

11. Accessories and Spare Parts

11.1. Accessories

We offer optional accessories to be installed before or after the delivery of the load break switches DRIWISA®:

- Trip coil system.
- Auxiliary contacts to indicate the main blade position.
- Auxiliary contacts to indicate the fuses position.
- Auxiliary contacts to indicate the grounding switch position.
- Disc operator mechanism.
- Dual fuse kit conversion.
- Fuse dimension kit conversion.
- Motor operates with local or remote operation.
- Pliers for high voltage fuses with wall holders.
- High voltage indicators.
- Conductive parts lubricant.

11.2. Spare Parts

We have all components parts to provide for maintenance of the load break switches DRIWISA®:

- Fuse clip holder.
- Complete pole (isolator and conductive parts).
- Live parts set (conductive parts).
- Insulators.
- Arc extinguish system.
- Quick break mechanism.
- Quick main mechanism.