



Design Portfolio

E
M
I
L
I
A
N
O

S
H
O
R
T

June 2026

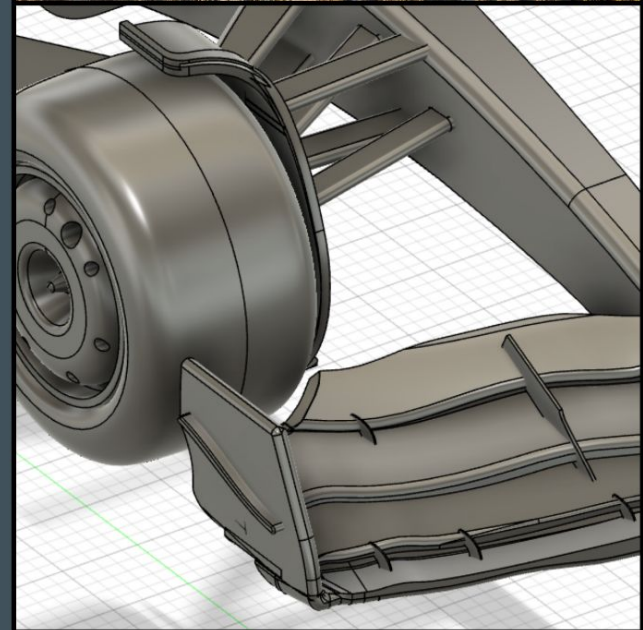



Emiliano Short

I am a 19 year old British-Canadian aspiring designer. I have skills in handmaking, CAD and graphic design, and I mean to develop them. I'm currently on my gap year, and I'm excited about the opportunity to get more experience and explore before I study product design at university in September 2026. I'm also a triathlete, an amateur linguist and a railway volunteer who spends perhaps too much time around trains.

I like bicycles, opera and languages. Maybe I'll find a way to involve design in all of those. For now I'm learning about design and the world. I hope to be able to gain industry experience over the next year- if you have any opportunities I'd love to talk to you about them. Thanks for exploring my portfolio.

short.gallery - emilianoshort@gmail.com - linktr.ee/emilianoshort

The template of this portfolio was designed in Inkscape by E. Short.

CAD - TINKERCAD AND FUSION 360

I've been developing my CAD skills since 2017, beginning with Tinkercad and later moving to Fusion 360. One of the first things I made was the fictional spacecraft Cosmonaut Alexei Leonov from the film 2010. I modelled this ship again twice, and I think the evolution is an excellent visualisation of how I have come along.

More recently, I have used Fusion to make vehicle models, some being used as a basis for 3D printed parts to make physical models, and some made to to be used for renders.

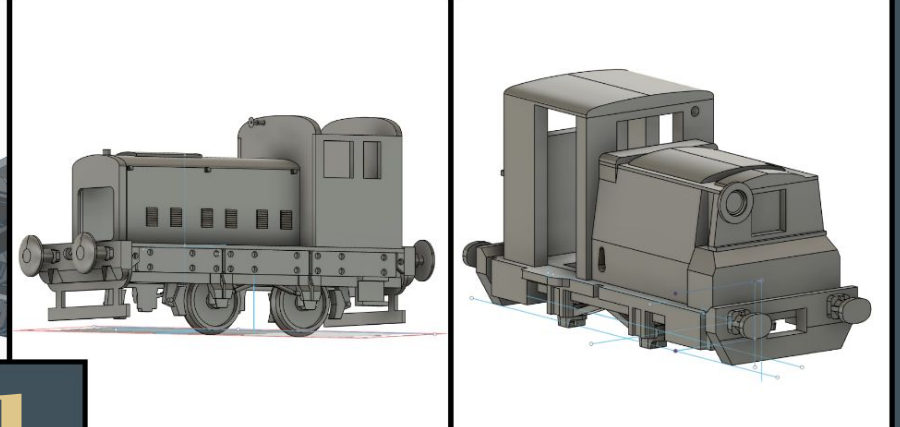
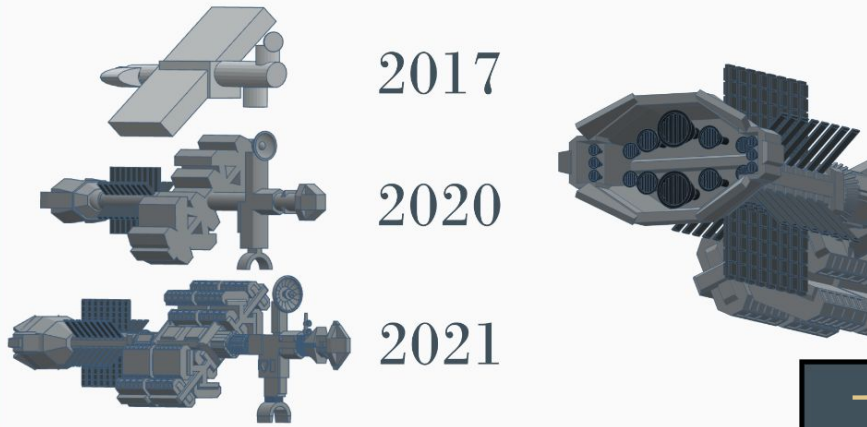
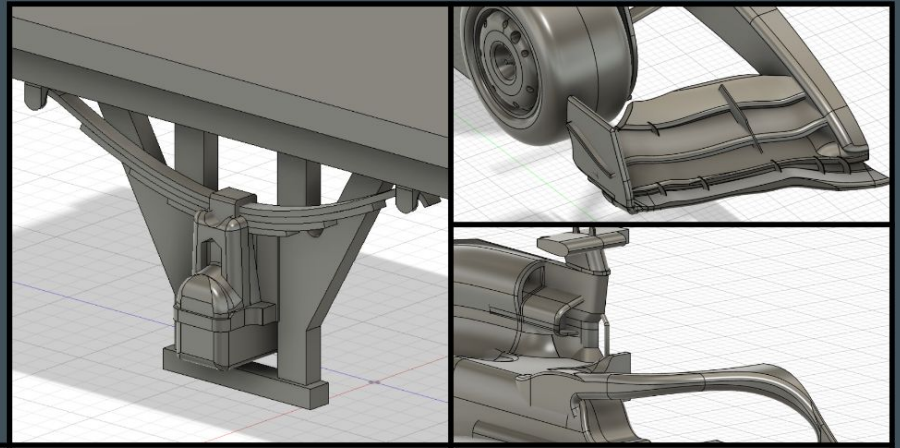

MODELS AND CERULEAN MODELLING

Since 2021 I've been developing my skills on my YouTube channel Cerulean Modelling. I use it to display my model work, and to improve in creating content. I find it very satisfying to improve on each project, and then do a video on it that is itself a project and an evolution. I plan to expand the CM project with a website (modelling.cc) and by making models commercially on a small scale.

More recently I started a second, German language channel, which uploads the same videos in German, and soon original videos of German-specific modelling. I look forward to using my second language to reach another community.



Cerulean Modelling

@cerulmo · 1.48k subscribers · 160 videos

Balancing time between modelling and procrastination. ...more

linktr.ee/cerulmo and 2 more links

Customise channel

Manage videos



Cerulean Modellbau DE

@CerulmoDE · 18 Abonnenten · 17 Videos

Deutschsprachiger Kanal für Cerulean Modellbau. ...mehr

linktr.ee/cerulmo

Kanal anpassen

Videos verwalten



THE FLYING KIPPER

2

Cerulean Modelling OO9 Talylyn Railway No. 5 'Midlander' for Tomytec TM-TR02 chassis

Complete bodyshell: 'CM ML complete'

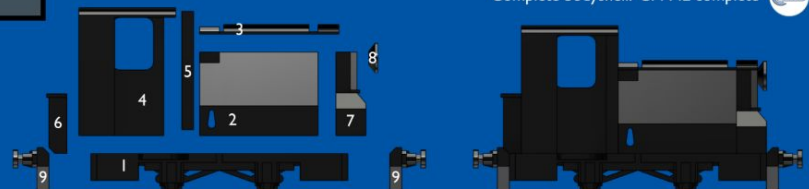

- 1. 'CM ML running board'
- 2. 'CM ML bonnet'
- 3. 'CM ML bonnet top'
- 4. 'CM ML cab'
- 5. 'CM ML spectacle plate'
- 6. 'CM ML toolbox'
- 7. 'CM ML radiator'
- 8. 'CM ML lamp'
- 9. 'CM ML bufferbeam' (type A or B)

'CM ML bufferbeam type A'

'CM ML bufferbeam type B'



LBORO UNI CHALLENGE - BABY MONITOR

In 2025 I was given a design challenge from Loughborough University to make a concept for a baby monitor. I used this as an opportunity to practice the conceptualisation of a project from a simple prompt quickly, from an idea to a proposal in a short time.

My main idea was to include features that track the health and position of the infant more actively, and can help prevent Sudden Infant Death Syndrome. The concept device features bluetooth tracking, an accelerometer and a heart rate monitor so that a baby can be checked on and kept safe.

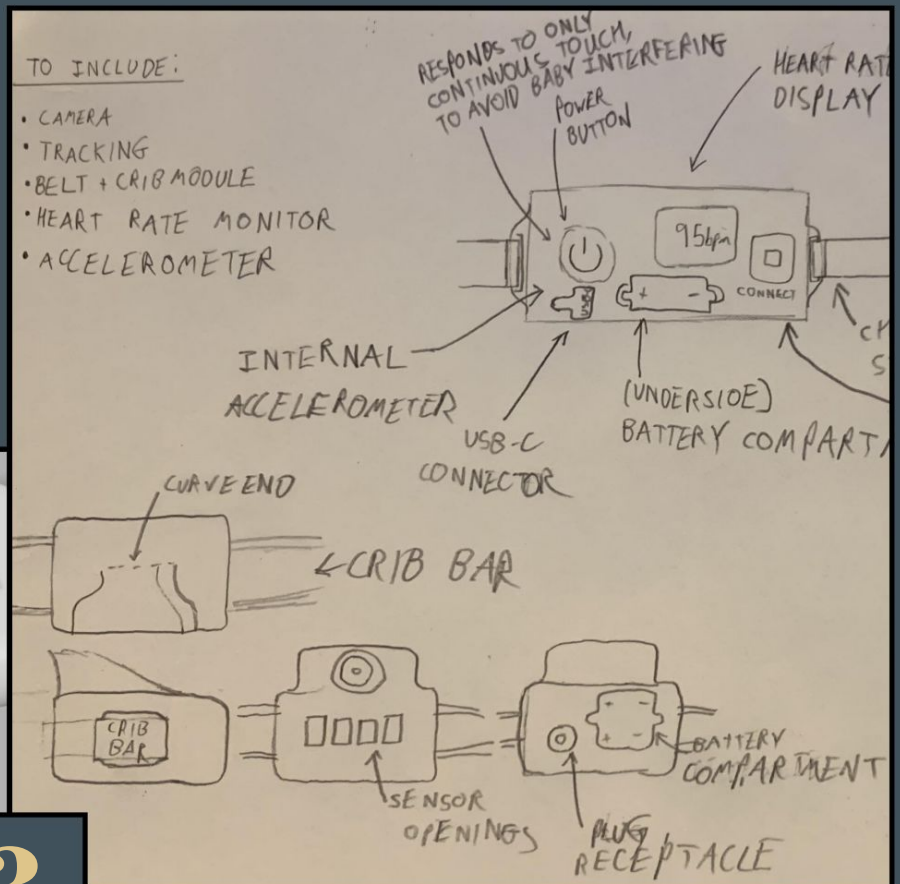
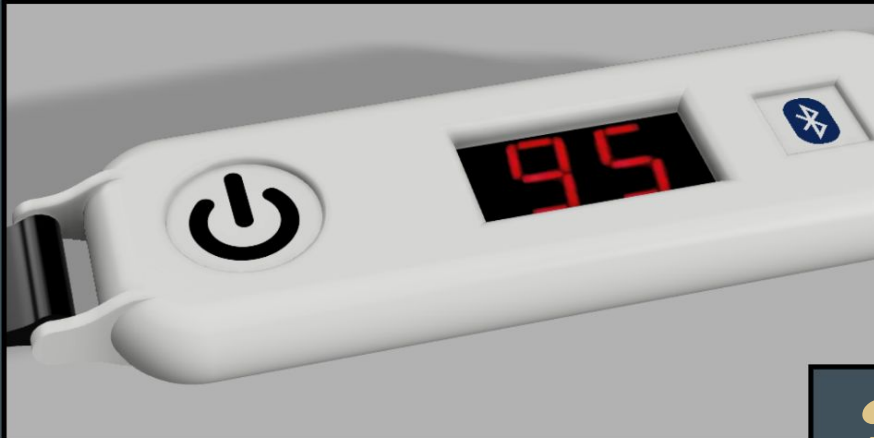

3



OSCILLATING CYLINDER STEAM ENGINE

During my time at the Pimlico Light Railway, I have learned a lot about machines. My most skill-developing project there was making this static steam engine as an off-season engineering project.

The boiler is copper, with hand beaten silver soldered end caps and machined brass upper fixtures. Under hydraulic testing, the boiler held a much higher pressure than required. The moving parts are steel and brass, with silver and normal solder. Precision was needed, as the holes through which the steam enters the cylinder must line up exactly at different points of the arc. The process greatly helped my eye for accuracy and my machining skills.

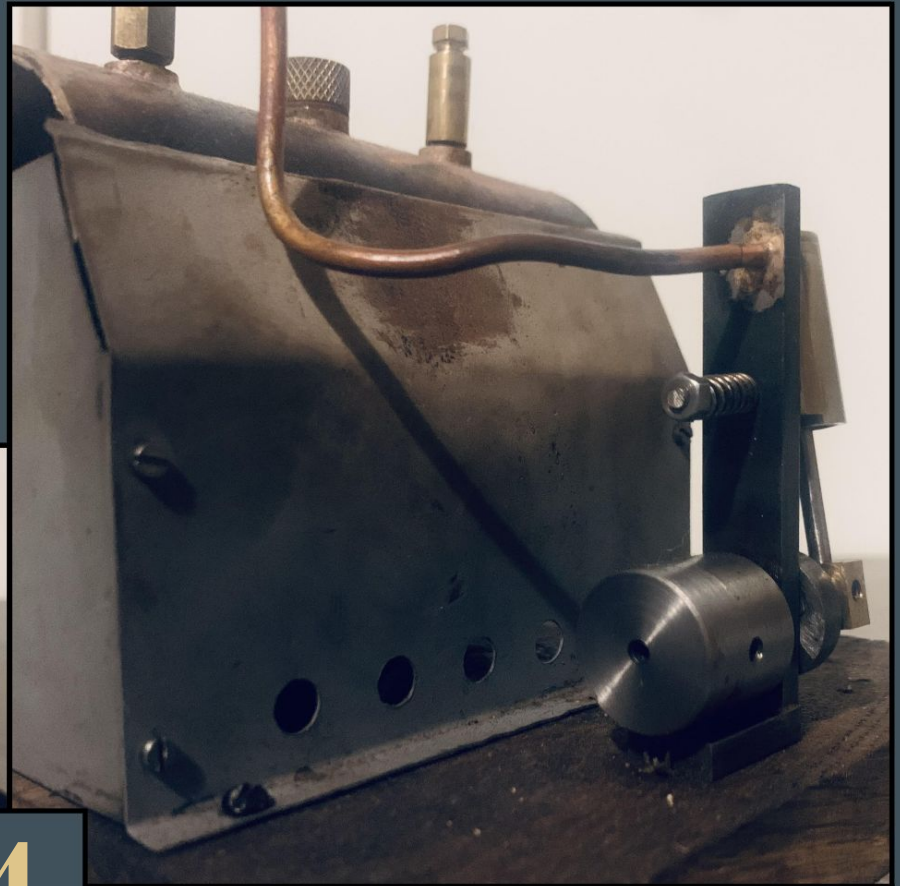

4

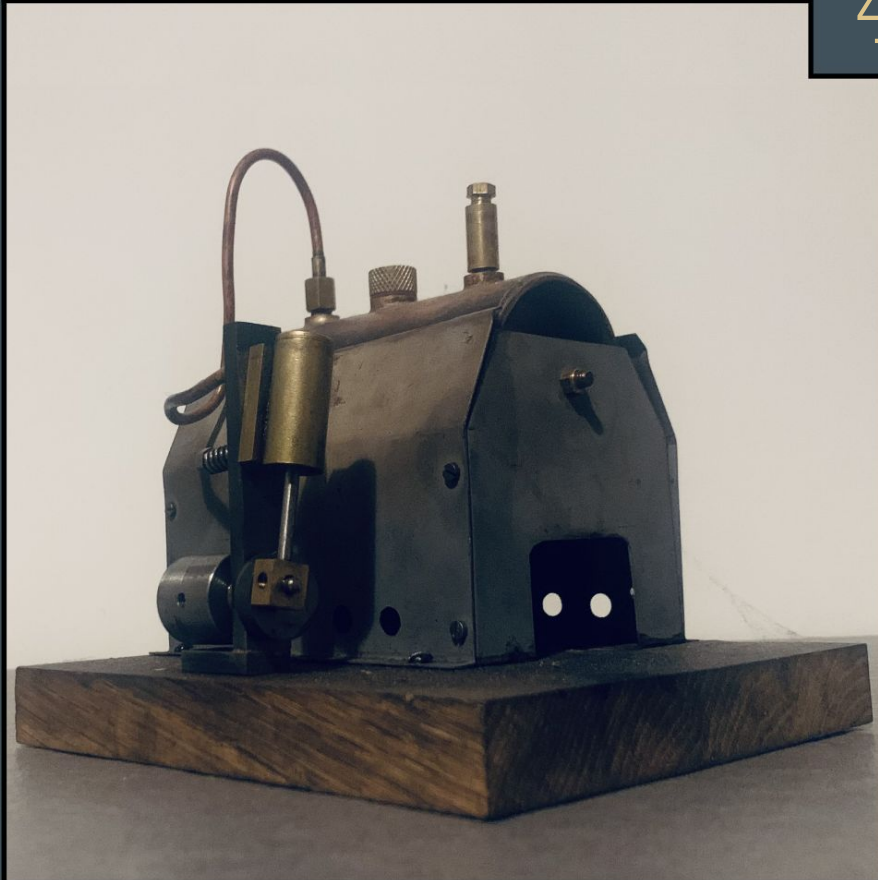

D6 ('EDWARD') - LOCOMOTIVE IN 1:76 - LES13

By far the most difficult yet rewarding model I've ever built is LES13, a 1:76 LNER D6, given a storybook livery. It was my first fully scratchbuilt motorised work, all made in-house, save wheel tyres and the motor. The model is a mix of parts handmade in styrene and 3D printed in PETG, with detailing made using wire and small hand tools. The livery is a mix of spray and freehand application.

I had so many problems to overcome in making this that it took a year on and off to complete. This is my most difficult and educational work to date, and the next generation of engines will benefit enormously from the knowledge gained.

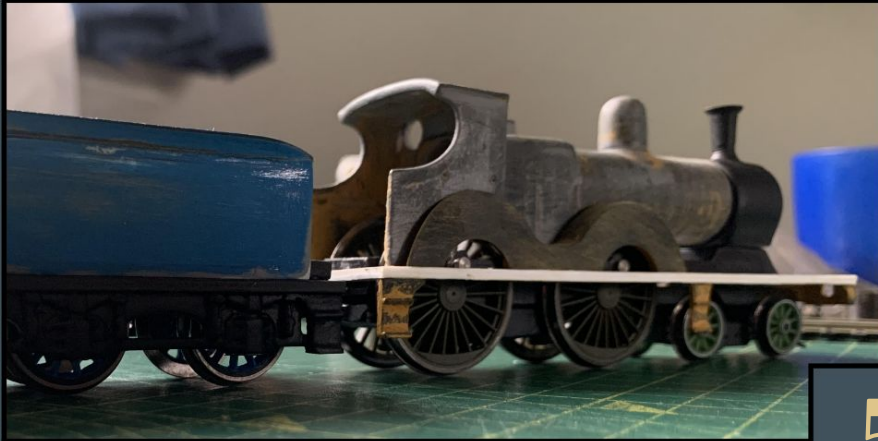

5



MILLIAN BIMOTIVE AND '211z-F' CONCEPT

A newer venture of mine is the sport focused internet presence and design project Millian Bimotive. Videos are still being planned, but the branding was a helpful exercise. I wanted a distinctive look, so that material stays recognisable. To this end I made the font 'Motiva Schrittschrift'. The influence of cycling can be seen, the B and T in particular being styled directly after racing bicycles.

The first MBM design exercise was the '211z-F' study, conceptualising a wooden bike frame. I made a basic design to show this in simple terms, first in 2D, and then in Fusion. I then made a mechanically complete 1:12 physical prototype.

MILLIAN BIMOTIVE

Millian Bimotive '211z-F' concept, August 2024



A concept for a home-built fixed gear road bike. Mostly commercial parts. Custom frame built of layered wood, central piece (A), spacer (B) and single side rear (C).

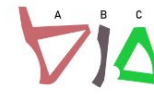

The single-sided fork may be insecure. If this is the case, a small steel structural member (D) could be used to make up the other side. This is a concept, not a full model. A full scale prototype will of course be subject to many alterations.

3 BIKES



MILLIAN BIMOTIVE



6



MILLIAN BIMOTIVE

MOTIVA SCHRITTSCHRIFT

A B C D E F G H I J K L
M N O P Q R S T U
V W X Y Z 0 1 2
3 4 5 6 7 8 9 ; : .

CERULEAN MODELLING LOCOMOTIVE PACKAGING

I really appreciate packaging, and think that manufacturers ought to put more thought into it. I want to sell models, and will need packaging that is practical, protective, and gives the product an enticing and professional image.

I made these prototypes for existing engines of different sizes. The shape is inspired by a kind of box common for commercial models, but with only card elements. With the graphics I tried to make a style that is individual to Cerulean Modelling. The plastic-less boxes ensure environmental friendliness, and I hope the final versions will complement my models well.

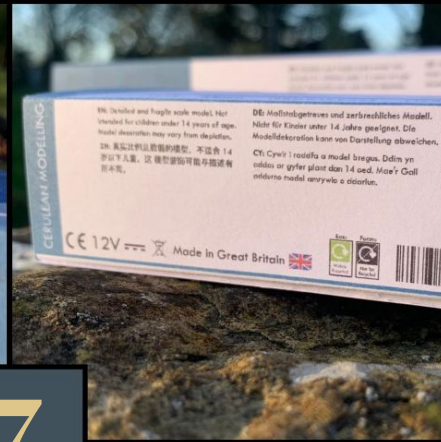
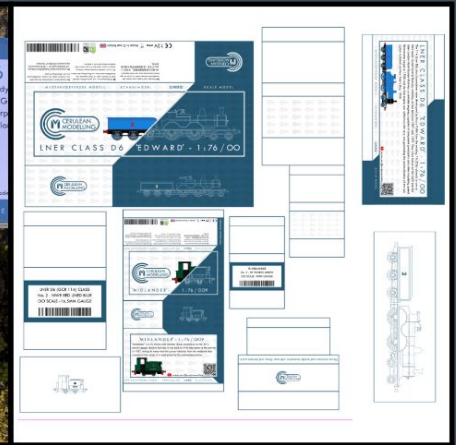

7

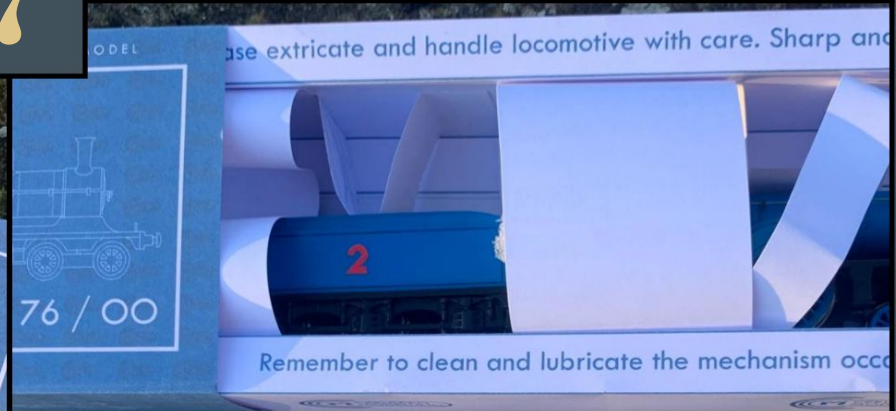

HYBRID IMAGE - THE FLYING KIPPER

In 2023 the Talylyn Railway held a challenge to recreate an illustration from the Railway Series books. Having earlier that year made a realistic short film of the story *The Flying Kipper*, I decided to continue this theme, but while using the strengths of a static image to evoke the feeling of a storybook illustration.

My technique for making films and images involves the fusion of physical and digital parts. The physical elements are the core, but the set is minimal- only the train and a few other objects. I took the challenge of editing in Inkscape, which produced a good result after much experimentation and layering.

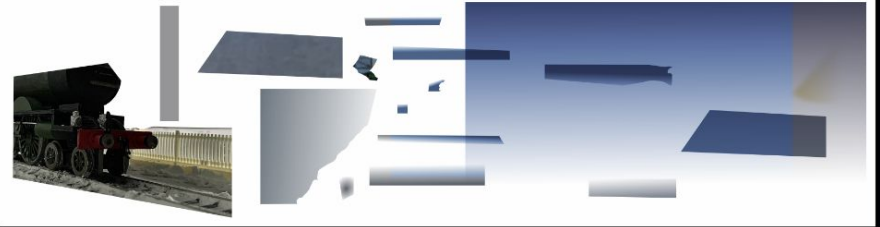

8



GRAPHIC DESIGN AND OTHER IMAGERY

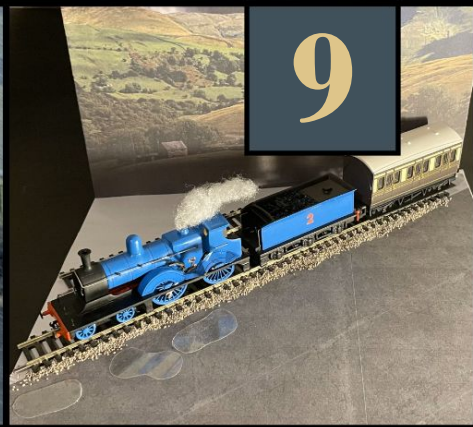
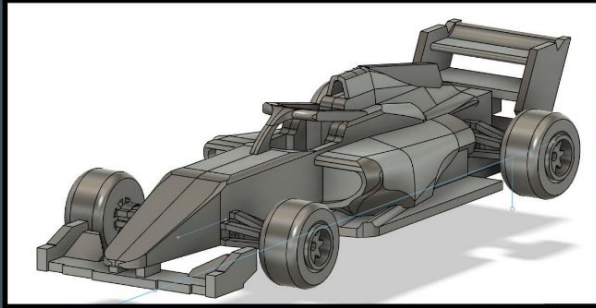

NOCH EINMAL AUF DEM WASSER

M.A.S. HEART
SCN-0101

BRAND POSITION - 2022/2023

THE MOTORIST
IS EVER
RESPONSIBLE
DRIVE WITH CAUTION

DER AUTOFAHRER
TRÄGT IMMER DIE
VERANTWORTLICHKEIT

FAHREN SIE MÉ VORSICHT

MSV - MMA

Miltenes Straßenverkehrsamt | Millian Motoring Authority

WHEN THE LINE BLURS

LEWIS HAMILTON

IRE

LEWIS HAMILTON
FRENCH EPY ANIMATIONS
PUPP PUPP ENTERTAINMENT, INC. - IRE CORPORATION
ALEXANDER MONTFERRIER 'DAY IN THE LIFE OF A MYSTICAL WOLF' ALEXANDER MONTFERRIER 'DARKEN & NIGHTS' DAN P. LYONS
JOSH PROCTOR 'YOU DON'T FALL' DAN P. LYONS 'CROSSING MOUNTAIN' DANIEL A. NICOLS 'DAMP' LYONS
ALEXANDER MONTFERRIER 'DARKEN & NIGHTS' DAN P. LYONS 'MUSICAL BLOOD' PUPP PUPP ENTERTAINMENT, INC. DANIEL A. NICOLS
BRADEN WARD 'DAMP' LYONS 'MUSICAL BLOOD' PUPP PUPP ENTERTAINMENT, INC. DANIEL A. NICOLS 'ALEXANDER MONTFERRIER' DANIEL A. NICOLS
BRADEN WARD 'DAMP' LYONS 'MUSICAL BLOOD' PUPP PUPP ENTERTAINMENT, INC. DANIEL A. NICOLS 'ALEXANDER MONTFERRIER' DANIEL A. NICOLS

HYPER
CAP

SARTHE

LEWIS HAMILTON
FRENCH EPY ANIMATIONS
PUPP PUPP ENTERTAINMENT, INC. - IRE CORPORATION
ALEXANDER MONTFERRIER 'DAY IN THE LIFE OF A MYSTICAL WOLF' ALEXANDER MONTFERRIER 'DARKEN & NIGHTS' DAN P. LYONS
JOSH PROCTOR 'YOU DON'T FALL' DAN P. LYONS 'CROSSING MOUNTAIN' DANIEL A. NICOLS 'DAMP' LYONS
ALEXANDER MONTFERRIER 'DARKEN & NIGHTS' DAN P. LYONS 'MUSICAL BLOOD' PUPP PUPP ENTERTAINMENT, INC. DANIEL A. NICOLS
BRADEN WARD 'DAMP' LYONS 'MUSICAL BLOOD' PUPP PUPP ENTERTAINMENT, INC. DANIEL A. NICOLS 'ALEXANDER MONTFERRIER' DANIEL A. NICOLS
BRADEN WARD 'DAMP' LYONS 'MUSICAL BLOOD' PUPP PUPP ENTERTAINMENT, INC. DANIEL A. NICOLS 'ALEXANDER MONTFERRIER' DANIEL A. NICOLS

ESCAPE

WORK IN PROGRESS - CALEDONIAN 652 IN 1:76

My next from-scratch locomotive project is underway. I chose the Caledonian Railway class 652, as I intend to make a film that features these engines. It will use much of the knowledge I gained in the process of making LES13/Edward, but I aim to move the standards of detail, mechanical and electrical systems, quality and practicality of construction to a new level.

I will need three of these engines, so this will be the first design of which multiple will be built. The practicality this requirement will bring to the design will make it a candidate for the first commercial Cerulean Modelling locomotive.

This engine will use the drive system that was created for LES13/Edward and developed further on a prototype chassis. This will be built around a small coreless motor, this time in the tender. This allows for more detail on the engine, and for compact, versatile propulsion. It is also more practical in terms of materials, as commercial tender wheels of a simple design and low cost can be used as the basis of the wheelsets. Non-driven wheels on the engine are free to be made exact to the real vehicle with fewer compromises.

The wheels are an evolution of past designs, but are much upgraded too. They use square axles in round bushings to give an easy way of aligning coupling rods. The wheel itself is in four parts- this makes painting substantially easier than if it were printed in a complete state.

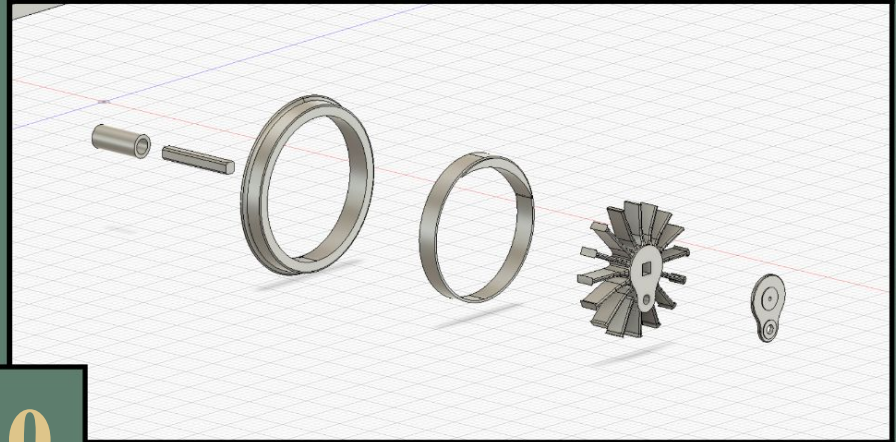
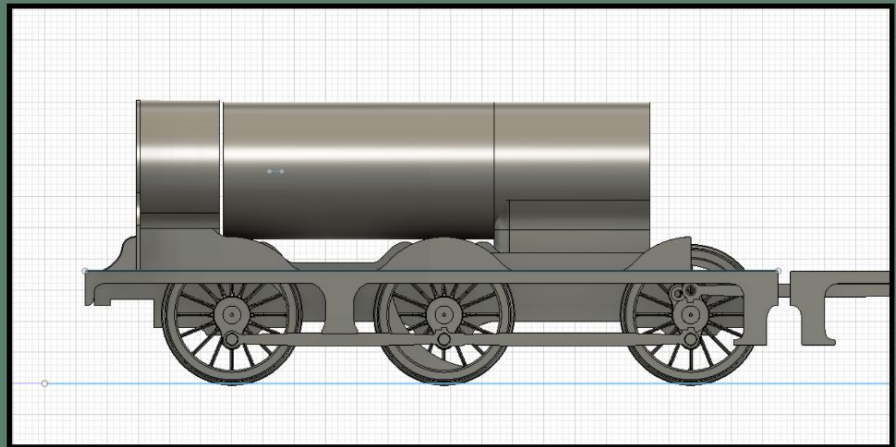

10

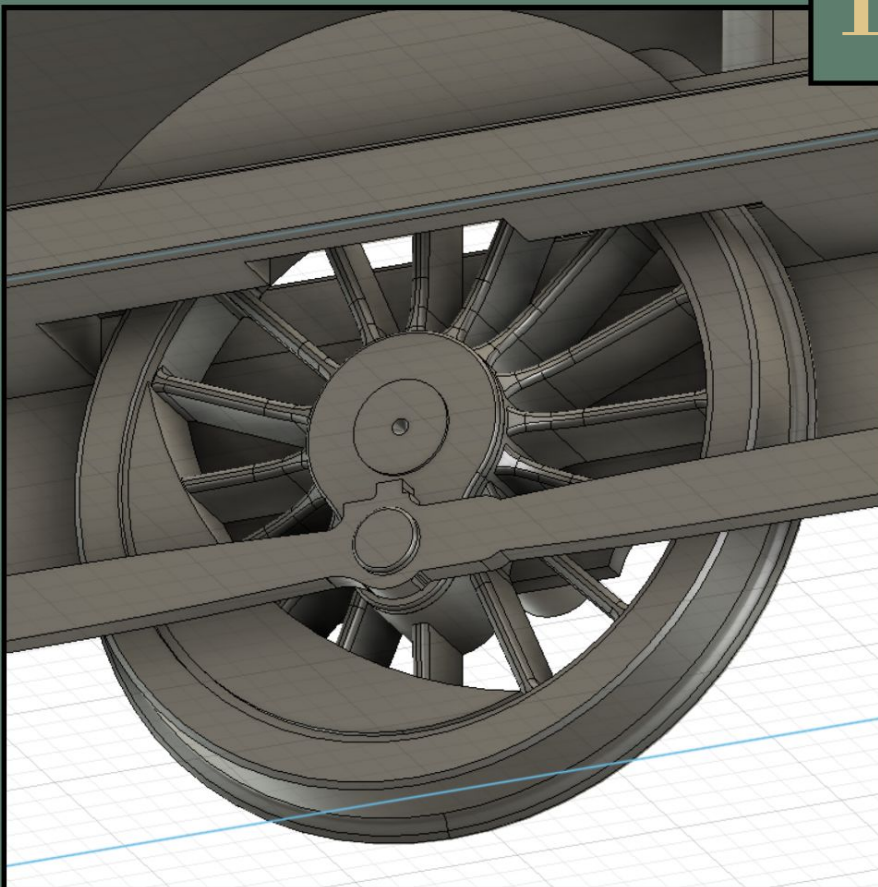

WORK IN PROGRESS - BRICKBUILT ENGINE KIT

Cerulean Modelling's first product came in early 2026. It is a branch into the modelling of trains using LEGO®-compatible elements. I had previously observed a demand among enthusiasts for a greater amount of realistic train models. I therefore decided to use the logistic challenge of producing a kit as an opportunity to make a first commercial offering.

The model was designed and prototyped in-house before I acquired the parts for a small pilot run from China. The instructions and packaging were then designed and tested for practicality. The wheels are custom 3D-printed and painted parts.

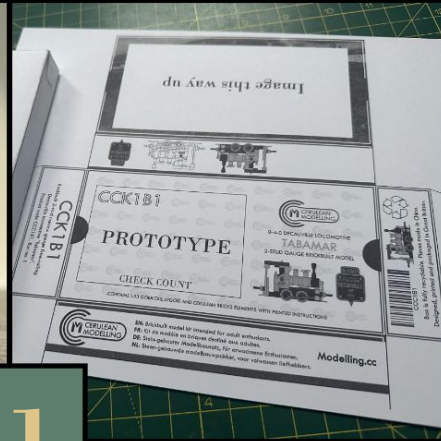
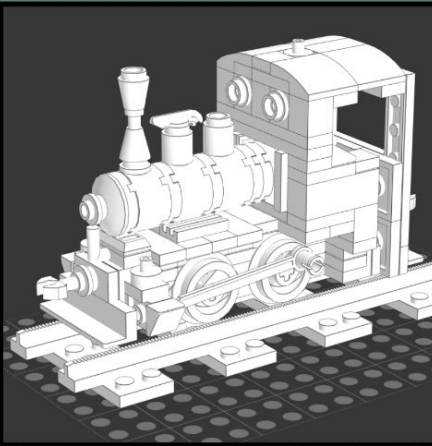

11



WORK IN PROGRESS - DICTIONARY TO MILENS

For some years I have been creating my own languages. I have written three languages at the time of writing. Having learned to speak both German and Dutch, my focus so far has been writing constructed members of the Germanic family that interact with the existing members in a real way.

One of these is intended as a realistic, historically supported language that might have developed as the tongue of a people like any other. Another evolved from the living, unique dialect of German that was organically, unintentionally created by my using it to think. The third began as a realistic West Germanic language, but has evolved into something grounded less in history and more in its own linguistic identity. This language is called Milens, and it is an excellent linguistic design outlet for me through its phonological aesthetics and grammatical inventiveness.

I see a link between languages, a typically unconscious human art, and the rest of art and creativity. Milens has been designed. Therefore this design mindset ought to carry over to its usage. I am currently compiling the body of the Milens language into a proper dictionary. The others will follow later but of the three, this is the one most artistically driven. I intend to use the design of the dictionary to learn about making a book, designing a cover, and to make certain the identity of language as a part of my design work.

Ongoing project: redubbing an episode of children's television

THOMAS DE TANKÆNGINA ESE WVREUNDE

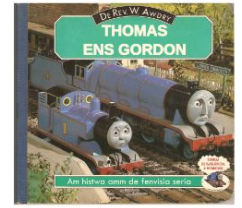

Thomas is a tank engine who lives at a big station on the Island of Sodor. He's a cheeky little engine, with 6 small wheels, a short, stumpy funnel, a short, stumpy boiler and a short, stumpy dome. He's a fussy little engine, too, always pulling coaches about ready for the big engines to take on long journeys. And when trains come in, he pulls the empty coaches away so that the big engines can go and rest.

Thomas la am tankængina, de aus am ro stagio a de illa Sodor wront. La am frac'h ænginej ese sehs kant rade, am kaur, coka kimnia, am kaur, coka kesal óc'h am kaur, coka doma. La ja am wéylen ænginej, alta cora em af zaien, zhodet des ro ængina de af lann faras tenen kan. Ent wain zoas apcomen, zaiet he de lair coras wec, zhodet des ro ængina saunen gén kan.

12

Ongoing project: translating the UDHR

De Leissengeman Bezhaseca vé Meslec Rekte - **The Universal Declaration of Human Rights in Milens**

Preamble

Whereas recognition of the inherent dignity and of the equal and inalienable rights of all members of the human family is the foundation of freedom, justice and peace in the world,

Pre'ame

Wa'inie de bekenenn der ænhurant niara ese des glai noc arátrenbe rekt vé leisen esglies der meslec familia de bahna ven réma, rekta ens paçe a wela la,



Thanks for reading.

Emiliano Short

short.gallery - emilianoshort@gmail.com - linktr.ee/emilianoshort

The template of this portfolio was designed in Inkscape by E. Short.