

专业分切机制造商

Professional provider of converting solution

RaLoyal合创

瑞安市合创机械制造有限公司
Ruian Loyal Machinery Co.,Ltd.

地址: 浙江省瑞安市东山街道上东路88号
Add: 1 Building, No.88 Shangdong Road,
Dongshan Economic Development Zone,Ruian,China

邮编(PC): 325200
销售热线(Tel): +86 0577 65138711
传真(Fax): +86 0577 65138712
手机(M.T): +86 18367750188
E-mail: ly@lyslitter.com

公司有权保留对机器技术参数的修改, 恕不另行通知。
Our company reserves the right to change technical
characteristics without further notice.

合创 —— 致力于为客户创造和提供价值
RaLoyal, Your loyal partner

RaLoyal合创



RaLoyal
YOUR LOYAL PARTNER
 致力为客户创造和提供价值

COMPANY PROFILE 公司介绍

Ruian Loyal Machinery Co.,Ltd located in Ruian city ,southeast of China, specializing in the slitting machine ,die cutting machine making for more than 14 years in the application of label /flexible packing/electric protector film/new energy and paper industry .

RaLoyal have been always devoted to provide a global solution to the demands of markets in constant development with competitive and tailored equipment including the latest solutions in innovation ,technology and sustainability for customers .

We deeply believe that RaLoyal will become your loyal partner once we have a chance to start the cooperation!

Global service center:

We have two exclusive agencies in the world currently, separated located in:

-Russia, Belarus,Estonia,Latvia,Lithuania Pre-sales and after-sales service

-Middle East: Egypt, Saudi Arabia,Iraq,Yemen, Libya, Oman Pre-sales and after-sales service

We can also provide local services in Venezuela, including installation and training.

瑞安市合创机械制造有限公司，坐落于浙江东海之滨---温州瑞安市，于2010年建厂以来，一直专注于分切机，模切机的研发和制造。

我们的使命是:为客户创造和提供价值。多年来，合创一直致力于为客户提供整体的，可持续发展和可定制的最新技术设备方案，方案具体明显的价格竞争力。

我们深深相信，只有为客户创造和提供价值，让客户的产品在市场更有竞争力，我们合创才能有更好的发展合创机械是您最忠实和长久的方案服务商!

全球代理:

我们目前在全球拥有两家独家代理，分别位于:

-俄罗斯、白俄罗斯、爱沙尼亚、拉脱维亚、立陶宛售前及售后服务

-中东:埃及、沙特阿拉伯、伊拉克、也门、利比亚、阿曼售前及售后服务

我们还可以在委内瑞拉提供本地服务，包括安装和培训。



OUR VALUES
 Integrity,Positivity,Earnest,Striving



OUR VISION
 Devoted to be a global professional provider of the converting solution



OUR MISSION
 Create and provide value to customers



PLUS SERIES

High Speed Jumbo Roll Slitting Machine 高速大卷径分切机

⊕ Features 特点

Plus series slitter rewinder machine purposely designed for large jumbo roll, for rewinding roll diameter is up to 1200mm. With a very solid unwinding stand and rewinding stand, the slitting speed can reach 600m/min. With the design for very convenient operation, can unload the finished jumbo roll by trolley easily on the ground. It is suitable for slitting and rewinding the label stock, all kinds of paper and laminated material etc.

Plus系列分切复卷机专为大型卷材而设计，收卷直径可达1200mm。机身具有非常稳固的放卷和收卷设计，分切速度可达600m/min。也具有非常方便的操控设计，可以轻松地将成品大卷卸到地面上。适用于标签纸、各种纸张、复合材料等的分切复卷。

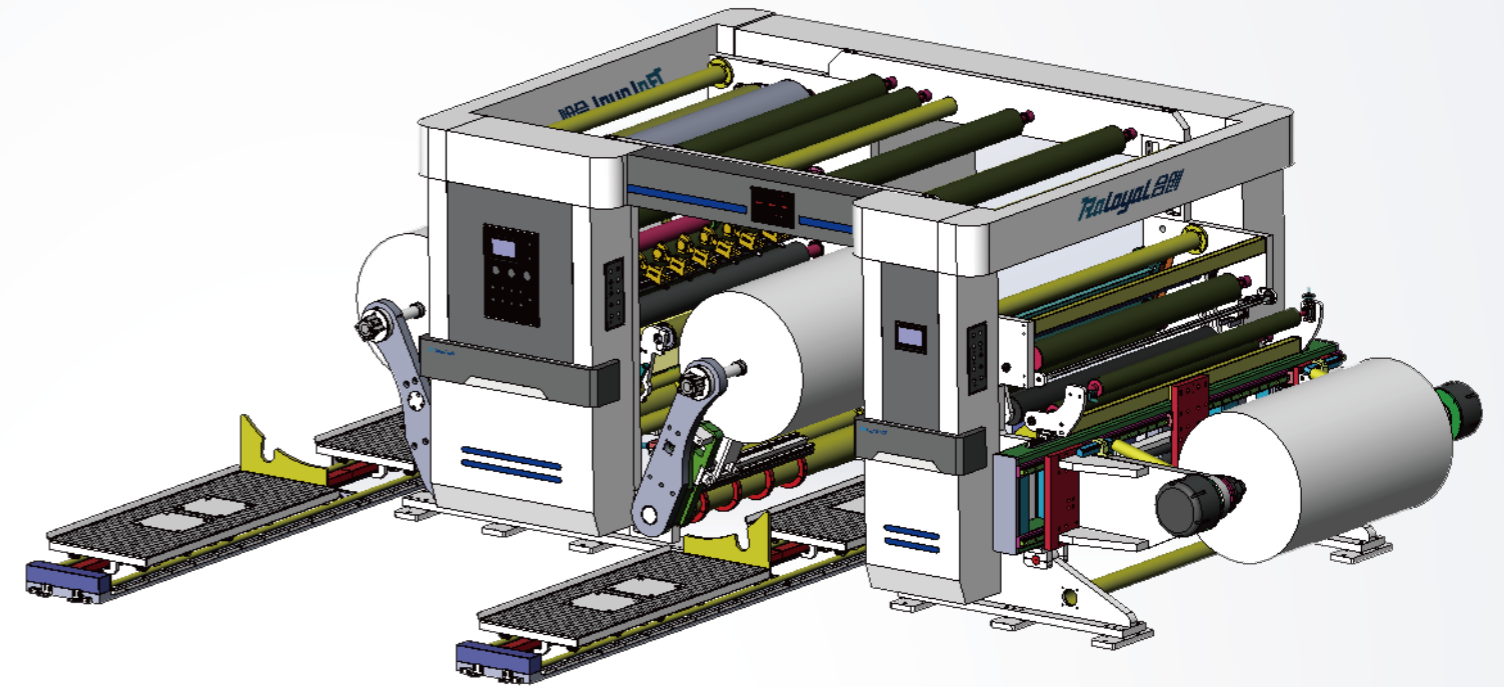

⊕ Advantages

- Rewind diameter 1200mm (Other bigger size can be customized)
- Automatic unloading trolley
- 5 sets Big power servo motor adopted
- Air knives equipped
- Full-auto blades set as option
- Overhead material path

优势

- 收卷直径可达1200mm (直径大于1200mm可定制)
- 导轨推车自动卸料
- 5个大功率伺服电机
- 配备气刀
- 选配全自动调刀
- 上走料

主要技术参数 Main Technical Parameter

Machine series	机器型号	HCH4-1300	HCH4-1600	HCH4-2200
Max Slitting speed	最大分切速度	600m/min	600m/min	600m/min
Max.Unwinding width	最大进料宽度	1300mm	1600mm	2200mm
Min. Slitting width	最小分切宽度	70mm	70mm	70mm
Max. Unwinding weight	最大放卷重量	3000-5000KG	3000-5000KG	3000-5000KG
Web guide	纠偏系统	Germany E+L	Germany E+L	Germany E+L
Automatic unloading trolley	自动卸料推车	Included	Included	Included

注：由于产品不断改进，机器外形及技术参数如有更改，恕不另行通知。
Note: as the products are developing day by day, the technical data are subject to change without notice.

PRO SERIES

Four-Axis Turret Slitting Rewinding Machine 四轴转换分切机

⊕ Application应用

Equipped 7 servo motors, to enable the machine slitting, rotating and rewinding precisely. Rewinding diameter even can be up to 800mm! Fully auto blade set, auto loading, 4 shaft turret, auto knife cutting, auto pushing and unloading, all the automations boost the efficiency and minus the downtime for customers.

设备配备7台伺服电机，确保分切、旋转、收卷精度。收卷直径可达最大800mm！全自动调刀，自动上料，4轴转换，自动切断，自动推料和自动卸料装置，为客户提高效率，减少劳动。



▲ Die cutting (Customized)
模切



▲ 4 Shaft turret non stop
4轴不停机转换



▲ Automatic knife cutting
自动切断



主要技术参数 Main Technical Parameter

Machine model	机器型号	HCT4-1300	HCT4-1600
Unwinding width	进料宽度	1300mm	1600mm
Unwinding diameter	放卷直径	Φ1200mm	Φ1200mm
Max. Rewinding diameter	最大收卷直径	Φ600mm (Φ800mm Customized)	Φ600mm (Φ800mm Customized)
Thickness range	厚度范围	0.012-0.2mm	0.012-0.2mm
Max. Slitting speed	最大分切速度	500m/min	500m/min
Min. slitting width	最小分切宽度	70mm	70mm
Traction power	牵引电机功率	5.5KW	7.5KW
Rewinding power	收卷电机功率	7.5KW*4	7.5KW*4

注：由于产品不断改进，机器外形及技术参数如有更改，恕不另行通知。
Note: as the products are developing day by day, the technical data are subject to change without notice.

XPERT SERIES

Fully Automatic High Speed Slitting Machine

全自动高速分切机

⊕ Application应用

This type high speed slitting machine is the most suitable machine for high speed and high precision demand of the jumbo roll material slitting and rewinding, such as: kraft paper, self adhesive paper, sticker, cardboard, electric screen protective film, laminated film, etc. Widely used in packing industry of food, beverage, personal care and pharmacy, electronics industry, logistics industry, medical industry, optical industry and so on.

这款高速分切机是最适合高速高精要求的大卷径材料分切收卷的机器，如：牛皮纸、不干胶纸、标签、纸板、电子屏幕保护膜、复合膜等。广泛应用于食品饮料，医药和个人护理等包装行业，电子行业、物流行业、医疗行业、光学行业等。



SPEED
500M/MIN



AUTOMATIC
UNLOAD



OVERHEAD
PATH

主要技术参数 Main Technical Parameter

Machine model	机器型号	HCH3-1300B	HCH3-1600B
Slitting speed	分切速度	500m/min	500m/min
Unwinding width	进料宽度	1300mm	1600mm
Unwinding diameter	放卷直径	Φ1200mm	Φ1200mm
Rewinding diameter	收料直径	Φ800mm	Φ800mm

注：由于产品不断改进，机器外形及技术参数如有更改，恕不另行通知。
Note: as the products are developing day by day, the technical data are subject to change without notice.

⊕ Advantages优势

- Individual shaft-less loading
独立无轴上料
- Fully automatic unloading
全自动卸料
- Overhead material path
上走料
- Double "S" structure
双S结构
- Semi-auto/full-auto blades set
半自动/全自动调刀
- 3 sets 11kw big power servo motors driven
3套11kw大功率伺服电机驱动

TOP A SERIES

High Speed Slitting Machine 高速分切机

Application应用

The Top A series machine is our hot selling model, also the most cost-efficient type for electronic protective film, optical film, PI film, PET/BOPP flexible film, etc. slitting and rewinding.

Top A系列是市场销量最好也是性价比最高的机型。广泛应用于电子保护膜、光学膜、PI膜、PET/BOPP软包装膜等分切和收卷。

- Protective film, PET, PVC, OCA, BOPP ■ 保护膜, PET, PVC, OCA, BOPP
- Adhesive paper ■ 不干胶



APPLICATION INDUSTRY :



主要技术参数 Main Technical Parameter

Machine model	机器型号	HCH3-1300A	HCH3-1600A
Slitting speed	分切速度	400m/min	400m/min
Unwinding width	进料宽度	1300mm	1600mm
Unwinding diameter	放卷直径	Φ1200mm	Φ1200mm
Rewinding diameter	收料直径	Φ600mm	Φ600mm

注：由于产品不断改进，机器外形及技术参数如有更改，恕不另行通知。
Note: as the products are developing day by day, the technical data are subject to change without notice.

POWER SERIES

1000mm Diameter Rewinding High Speed Slitting Machine 1000mm收卷直径高速分切机

Application应用

This machine is professionally for jumbo roll slitting rewinding. Max rewinding diameter up to 1200mm. Automatic shaft-less loading, automatic chain unloading, assure the operation more friendly and safety. it is widely used for:

本机特别适用于大收卷直径需求的客户。最大收卷直径可达1200mm。全自动无轴上料，自动链条式下料，确保了机器的操作更快捷和安全，适用于大卷标签、纸袋母卷、纸杯或纸碗母卷、食品包装纸、复合材料卷等各种大型卷材的高精度分切和收卷。

- Jumbo label roll slitting and rewinding
巨型标签卷分切复卷
- Paper bags feeding roll
纸袋母卷
- Paper cups/bowls bottom roll
纸杯/碗底卷
- Food packing paper roll
食品包装纸卷
- Laminated rolls
复合材料

Advantages优势

- Individual shaft-less loading
独立无轴上料
- Automatic unloading by chain
链条自动卸料
- Max 1200MM big rewinding diameter
最大 1200mm大卷径收卷
- 3 sets 4kw+11kw+11kw big power servo motors driven
4kw+2*11kw大功率伺服电机驱动



FOR JUMBO ROLL



CHAIN UNLOADING



AUTOMATIC SHAFTLESS LOADING

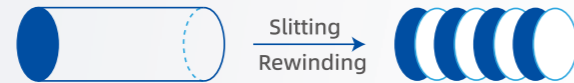

主要技术参数 Main Technical Parameter

Machine model	机器型号	HC-Z1300	HC-Z1600	HC-Z1800
Slitting speed	分切速度	500m/min	500m/min	500m/min
Unwinding width	进料宽度	1300mm	1600mm	1800mm
Unwinding diameter	放卷直径	Φ1200mm	Φ1200mm	Φ1200mm
Rewinding diameter	收料直径	Φ1000mm	Φ1000mm	Φ1000mm

注：由于产品不断改进，机器外形及技术参数如有更改，恕不另行通知。
Note: as the products are developing day by day, the technical data are subject to change without notice.

TOP B SERIES

High Speed Slitting Machine 高速分切机

Application应用

The Top B series machine is our hot selling model, also the most cost-efficient type for Self-adhesive Paper, Silicon Coated Paper, thermal Paper, Laminated materials, PET/BOPP flexible film, etc. slitting and rewinding.

Top B系列是市场销量最好也是性价比最高的机型。广泛应用于不干胶纸、硅油纸、热敏纸、复合膜、PET/BOPP软包装膜等分切和收卷。

- Adhesive paper
- Paper
- Laminated material
- Protective film, PET, PVC, OCA, BOPP
- 不干胶
- 纸张
- 复合材料
- 保护膜, PET, PVC, OCA, BOPP

Advantages

- Full automatic blade set
- Automatic push
- Shaft-less loading

优势

- 全自动调刀
- 自动推料
- 无轴上料



主要技术参数 Main Technical Parameter

Machine model	机器型号	HCH2-1300A	HCH2-1600A
Slitting speed	分切速度	400m/min	400m/min
Unwinding width	进料宽度	1300mm	1600mm
Unwinding diameter	放卷直径	Φ800mm	Φ800mm
Rewinding diameter	收料直径	Φ600mm	Φ600mm

注：由于产品不断改进，机器外形及技术参数如有更改，恕不另行通知。
Note: as the products are developing day by day, the technical data are subject to change without notice.

CORE SERIES

Surface Coiling Slitting Machine 表面卷取分切机

Application应用

This machine adopts central coiling and surface contact rewinding, each rewinding shaft is controlled by a separate servo motor. Much Suitable to slit and rewind for aluminum foil, cooper foil, paper and the easy stretching plastic film, such as BOPP/PET/PVC/PET etc.

本机采用中心表面接触收卷，每根收卷轴由单独的伺服电机控制。适用于铝箔、铜箔、纸张及BOPP/PET/PVC/PET等易拉伸塑料薄膜的分切和收卷。

Advantages

- Min. Slitting width 5mm
- 3sets servo motor control
- Suitable for various material slitting

优势

- 最窄分切宽度 5mm
- 3伺服电机控制
- 适合多种材料分切



主要技术参数 Main Technical Parameter

Machine model	机器型号	HC-C650B	HC-C1300B	HC-C1600B
Slitting speed	分切速度	300m/min	300m/min	300m/min
Unwinding width	进料宽度	650mm	1300mm	1600mm
Min slitting width	最小分切	5mm	7mm	10mm
Unwinding diameter	放卷直径	Φ600mm	Φ1000mm	Φ1000mm
Rewinding diameter	收料直径	Φ600mm	Φ600mm	Φ600mm

注：由于产品不断改进，机器外形及技术参数如有更改，恕不另行通知。
Note: as the products are developing day by day, the technical data are subject to change without notice.

BASIC SERIES

Multifunctional Laminating Slitting Machine 多功能贴合分切机

Characteristics特点

Basic series is an economic type machine for label, protective film materials slitting, It can be custom-made peeling, multi-layer lamination, etc. function as client requirement. Not only can slit the label and film material, but also can be tailored for lithium battery pole pieces slitting and rewinding.

Basic series 贴合分切机是一款经济型的不干胶，保护膜分切设备，另可根据客户需求定制剥离，多层贴合功能。对复合材料、不干胶、薄膜具有很强的适应性，也可用于锂电池极片材料的分切。

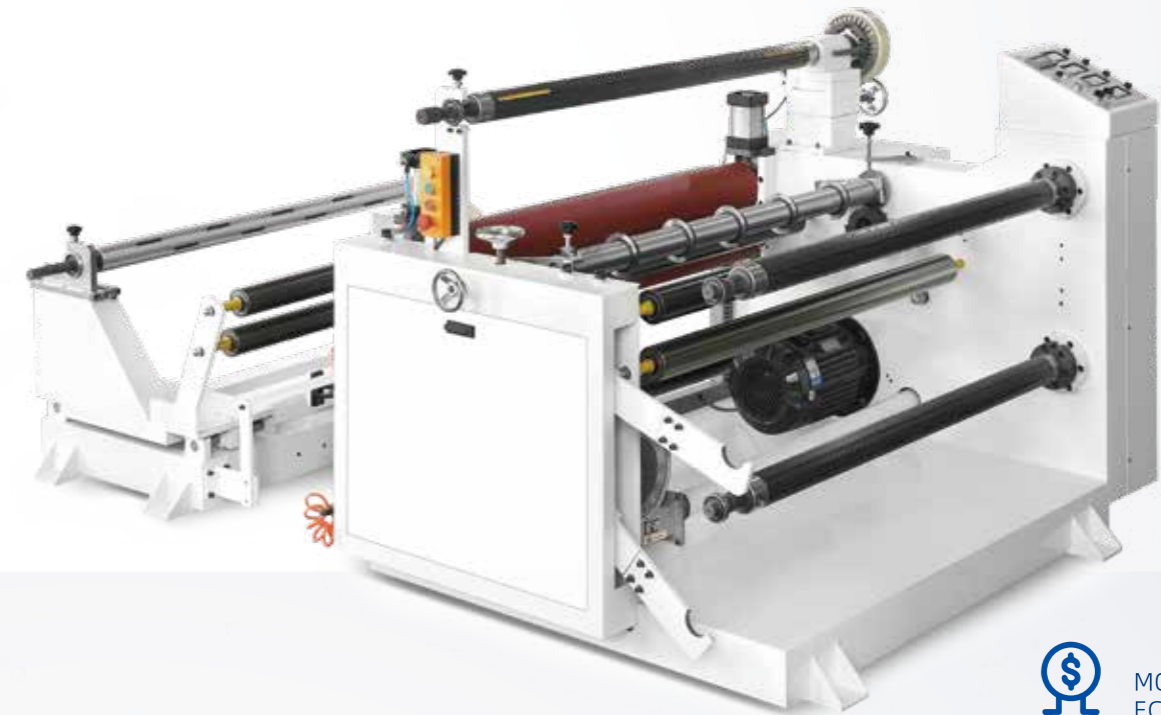

 MOST ECONOMIC TYPE

 FILM/LABEL APPLICATION

主要技术参数 Main Technical Parameter

Machine model	机器型号	HC-1300	HC-1600
Slitting speed	分切速度	100m/min	100m/min
Unwinding width	进料宽度	1300mm	1600mm
Unwinding diameter	放卷直径	Φ800mm	Φ800mm
Laminating diameter	覆膜直径	Φ300mm	Φ300mm
Rewinding diameter	收料直径	2*Φ450mm	2*Φ450mm

注：由于产品不断改进，机器外形及技术参数如有更改，恕不另行通知。
Note: as the products are developing day by day, the technical data are subject to change without notice.

HCH2-1300R/1600R

High Speed Single Shaft Rewinding Machine 高速单轴复卷机

Application应用

This type machine is used for big diameter roll rewinding. Max rewinding diameter up to 800mm. Widely used for paper, Silicon Coated Paper, Self-adhesive Paper, Aluminum Foil + Paper, NCR Paper, Non-woven Cloth, Nylon, Laminate films , PET/BOPP film ,etc. rewinding.

本机适用于大卷径材料复卷。最大复卷直径可达800mm。广泛应用于纸张、硅涂层纸、不干胶纸、铝箔+纸、NCR纸、无纺布、尼龙、复合膜、PET/BOPP薄膜等复卷。



FOR JUMBO ROLL
REWINDING

CAN BE
TAILORED

主要技术参数 Main Technical Parameter

Machine model	机器型号	HCH2-1300R	HCH2-1600R
Rewinding speed	复卷速度	300m/min	300m/min
Unwinding width	进料宽度	1300mm	1600mm
Unwinding diameter	放卷直径	Φ1000mm	Φ1000mm
Rewinding diameter	收料直径	Φ800mm	Φ800mm

注：由于产品不断改进，机器外形及技术参数如有更改，恕不另行通知。
Note: as the products are developing day by day, the technical data are subject to change without notice.

HCH3-1300R2/1600R2

High Speed Turret Rewinding Machine 高速双轴复卷机

Application应用

This machine is specialized for small diameter roll rewinding. Max rewinding diameter up to 220mm. Machine with turret rewinder, non-stop automatic roll change, automatic flying knife cutting and automatic packaging, automatic standing to improve efficiency and save man power.

本机专门用于小卷径材料复卷。最大复卷直径达220mm。该机采用双轴旋转复卷，不停机自动换卷，成品自动飞刀切断、包装，自动站立，提高效率，节省人力。

Features

- Shaft-less heavy duty loading
- Dual shafts turret rewinding
- Automatic knife cutting
- Automatic push (option)
- Automatic packing (option)

功能

- 无轴液压上料
- 双轴旋转复卷
- 飞刀自动切断
- 自动推料(选配)
- 自动包装(选配)



主要技术参数 Main Technical Parameter

Machine model	机器型号	HCH3-1300R2	HCH3-1600R2
Rewinding speed	复卷速度	300m/min	300m/min
Unwinding width	进料宽度	1300mm	1600mm
Unwinding diameter	放卷直径	Φ1200mm	Φ1200mm
Rewinding diameter	收料直径	Φ300mm	Φ300mm

注：由于产品不断改进，机器外形及技术参数如有更改，恕不另行通知。
Note: as the products are developing day by day, the technical data are subject to change without notice.

LY-807

Double Shaft Tape Rewinding Machine 双轴胶带复卷机

Application应用

This machine is suitable for small diameter material rewinding. Widely used for masking tape, BOPP tape, double side tape, various adhesive and non-adhesive substrates rewinding.

本机适用于小直径复卷。广泛用于遮蔽胶带、BOPP胶带、双面胶带等各种有胶和无胶基材的复卷。

Advantages

- Dual-shaft non-stop automatic changing
- High speed brush-less motor
- PLC and touch screen control
- All shafts adopted Japan Teflon treatment
- Automatic cutting
- Hydraulic loading (option)
- Automatic label sticking (option)

优势

- 双轴自动转换
- 高速无刷电机
- PLC和触摸屏控制
- 所有轴均采用日本特氟龙处理
- 自动飞刀
- 液压上料装置(可选)
- 自动贴标(可选)



主要技术参数 Main Technical Parameter

Machine model	机器型号	LY-807
Slitting speed	分切速度	200 m/min
Unwinding width	进料宽度	1300mm
Unwinding diameter	进料直径	Φ800mm
Rewinding diameter	收料直径	Φ200mm
Core inner diameter	轴芯内径	3 inch
Unwinding tension brake	放卷张力制动器	10KG

注：由于产品不断改进，机器外形及技术参数如有更改，恕不另行通知。
Note: as the products are developing day by day, the technical data are subject to change without notice.

LY-701/703/704

Tape Log Slitter 胶带分切机

Application应用

This type machine is most suitable for the world famous brand :3M ,TESA, Norton etc small roll tape Such as transparent sealing tape ,double side tape, electrical tape, Mylar silicone adhesive tape, masking tape, foam tape, medical tape etc. cutting.

本机适用于3M、德莎、诺顿等世界知名品牌小卷径超透明封箱胶带、双面胶带、电工胶带、麦拉胶带、美纹纸胶带、泡沫胶带，医疗胶带等的分切。

Advantages

- Suitable for various tape materials slitting
- Min slitting width: 1mm
- Max slitting width: 2300mm

优势

- 适用于各种胶带材料的分切
- 最小分切宽度：1mm
- 最大分切宽度：2300mm



主要技术参数 Main Technical Parameter

Machine model	机器型号	LY-701	LY-703	LY-704
Slitting speed	分切速度	35 cuts/min	35 cuts/min	35 cuts/min
Material width	进料宽度	1300mm	1300mm	1300mm
Material diameter	材料直径	Φ350mm	Φ200mm	Φ150mm
Min slitting width	最小分切宽度	1mm	1mm	1mm

注：由于产品不断改进，机器外形及技术参数如有更改，恕不另行通知。
Note: as the products are developing day by day, the technical data are subject to change without notice.

HC-H350/H480

Narrow web high speed slitting machine 窄幅高速分切机

Application应用

This type machine is our latest innovation for high speed sticker label roll converting. Machine adopts full servo driven system, taper tension control system, top brand web guiding, turret rewinder, variable size shafts exchange, meter & number counting, and less material automatic speed reduction or stop etc., greatly improve the production efficiency.

该机型是我司最新研发的高速不干胶标签分切复卷机。该机采用全伺服驱动系统，锥度张力控制系统，知名品牌纠偏系统，双收卷轴全自动旋转换位装置，支持多种规格气涨轴随意互换，支持记米、计数，少料自动降速或停机等，大大提高生产效率。

Advantages

- High speed slitting: 350m/min
- Turret rewinder
- Full servo driven
- Taper tension control system
- PLC control
- Max rewind roll diameter up to 700mm
- Full automatical knife positioning as option

优势

- 高速分切：350m/min
- 旋转收卷
- 全伺服控制
- 锥度张力控制系统
- PLC控制
- 单收最大直径700mm
- 选配：全自动调刀



主要技术参数 Main Technical Parameter

Machine model	机器型号	HC-H350	HC-H480
Slitting speed	分切速度	350 m/min	350m/min
Unwinding width	进料宽度	350mm	480mm
Unwinding diameter	进料直径	Φ700mm	Φ800mm
Rewinding diameter	收料直径	Φ450mm	Φ450mm
Machine weight	机器重量	1300KG	1500kg
Installation dimension	安装尺寸	1800*1350*1350mm	2200*1460*1350mm

注：由于产品不断改进，机器外形及技术参数如有更改，恕不另行通知。
Note: as the products are developing day by day, the technical data are subject to change without notice.

HCHR-350/480

Narrow web high speed inspection slitting machine 窄幅高速检标分切机

Application应用

This type machine is our latest innovation for high speed sticker label roll inspection and slitting. Machine adopts full servo driven system, taper tension control system, top brand web guiding, turret rewinder, variable size shafts exchange, meter & number counting, and less material automatic speed reduction or stop etc., greatly improve the production efficiency.

该机型是我司最新研发的高速检标分切机。该机采用全伺服驱动系统，锥度张力控制系统，知名品牌纠偏系统，双收卷轴全自动旋转换位装置，支持多种规格气涨轴随意互换，支持记米、计数，少料自动降速或停机等，大大提高生产效率。

Advantages

- High speed slitting: 350m/min
- Turret rewinder
- Full servo driven
- Taper tension control system
- PLC control
- Max rewind roll diameter up to 700mm
- Online inspection system as option

优势

- 高速分切：350m/min
- 旋转收卷
- 全伺服控制
- 锥度张力控制系统
- PLC控制
- 单收最大直径700mm
- 选配：在线检标系统



主要技术参数 Main Technical Parameter

Machine model	机器型号	HCHR-350	HCHR-480
Slitting speed	分切速度	350 m/min	350m/min
Unwinding width	进料宽度	350mm	480mm
Unwinding diameter	进料直径	Φ700mm	Φ800mm
Turret rewinding diameter	旋转收卷直径	Φ450mm	Φ450mm
Lower rewinding diameter	下收卷直径	Φ600mm	Φ600mm
Machine weight	机器重量	1800kg	2000kg
Installation dimension	安装尺寸	2980*1250*1690mm	2980*1380*1690mm

注：由于产品不断改进，机器外形及技术参数如有更改，恕不另行通知。
Note: as the products are developing day by day, the technical data are subject to change without notice.

LYDG-370/470/570

Full Automatic Glueless Non-stop Turret Rewinder 全自动无胶不停机复卷机

Application应用

LYRG series turret rewinder is with matured and most advanced technology in the world, own the ability to work in-line with die cutting machine, printing machine, slitting machine and work off line as a stand-alone solution with a separate unwinder, Automatic tube threading, glueless rewinding, automatic cutting & rewinding and automatic label sticking, which can finish your customer's orders quickly, shorten the lead-time, increase your productivity, save your labor cost and raise your product competitive advantage in the market.

LYRG系列4轴转换复卷机采用世界上最成熟、最先进的技术，可与模切机、印刷机、分切机联机工作，或单独放卷，脱机工作。具有自动穿管，无胶收卷，自动切断和复卷，自动贴标等功能快速完成客户的订单，缩短交货周期，提高您的生产效率，节省您的人工成本，提高产品的市场竞争力。

Advantages优势

- Servo driven and with accurate automatic loop tension control
- Can handle a wide range of roll width: 330, 450 and 570mm
- Glue free system can be selected
- Both Blank label and printed label are available
- Precision cut in gap of finished label roll
- Servo motor control Mechanical arm automatic feeding system

优势

- 伺服驱动，带有精确的自动环张力控制
- 可应用于卷材宽：370，470和570mm
- 有无胶系统可供选择
- 适用于空白标签和印刷标签
- 精密切割成品卷标签缝隙
- 伺服控制机械臂自动排管系统



主要技术参数 Main Technical Parameter

Machine model	机器型号	LYD-370	LYD-470	LYD-570
Rewinding diameter	收料直径	φ350mm	φ350mm	φ350mm
Rewinding speed	收卷速度	50-120m/min	50-120m/min	50-120m/min
Min. Rewinding width	最小收料宽度	30mm	50mm	50mm
Total power	总功率	10KW	12KW	15KW
Machine Dimensions	机器尺寸(mm)	1500*3000*1700	1500*3200*1700	1500*3400*1700
Weight	重量	2200kg	2500kg	2800kg

注：由于产品不断改进，机器外形及技术参数如有更改，恕不另行通知。
Note: as the products are developing day by day, the technical data are subject to change without notice.

LY-RS350/RS450

Semi-Rotary Die cutting machine 间歇式模切分切机

Application应用

This machine equipped with register sensor, applicable for both pre-printed labels and blank labels die cutting and slitting. It can be run with semi-rotary mode as well as full rotary mode. With semi-rotary time, the machine doesn't need to change different magnetic cylinders for different labels. The machine has the characteristics of compact structure, fast speed, high efficiency, easy operation, accurate die cutting, steady running etc.

本机配有色标跟踪，适用于印刷标签和空白标签的模切和分切。它具有间歇式和全轮转两种模式。当机器使用间歇式模式时，不需要因为不同尺寸的标签去更换磁性辊。机器具有结构紧凑、速度快、效率高、操作方便、模切精准、运行平稳等特点。



主要技术参数 Main Technical Parameter

Machine model	机器型号	LY-RS350	LY-RS450
Material width	进料宽度	350mm	450mm
Max unwinding diameter	放料直径	700mm	
Max rewinding diameter	收料直径	700mm	
Die cutting speed	模切速度	65m/min (Semi-rotary)	120m/min (Full-rotary)
Total power	总功率	12KW	

注：由于产品不断改进，机器外形及技术参数如有更改，恕不另行通知。
Note: as the products are developing day by day, the technical data are subject to change without notice.

LDC-350A/450A

Label Flat Bed Die Cutting Machine 标签平压平模切机

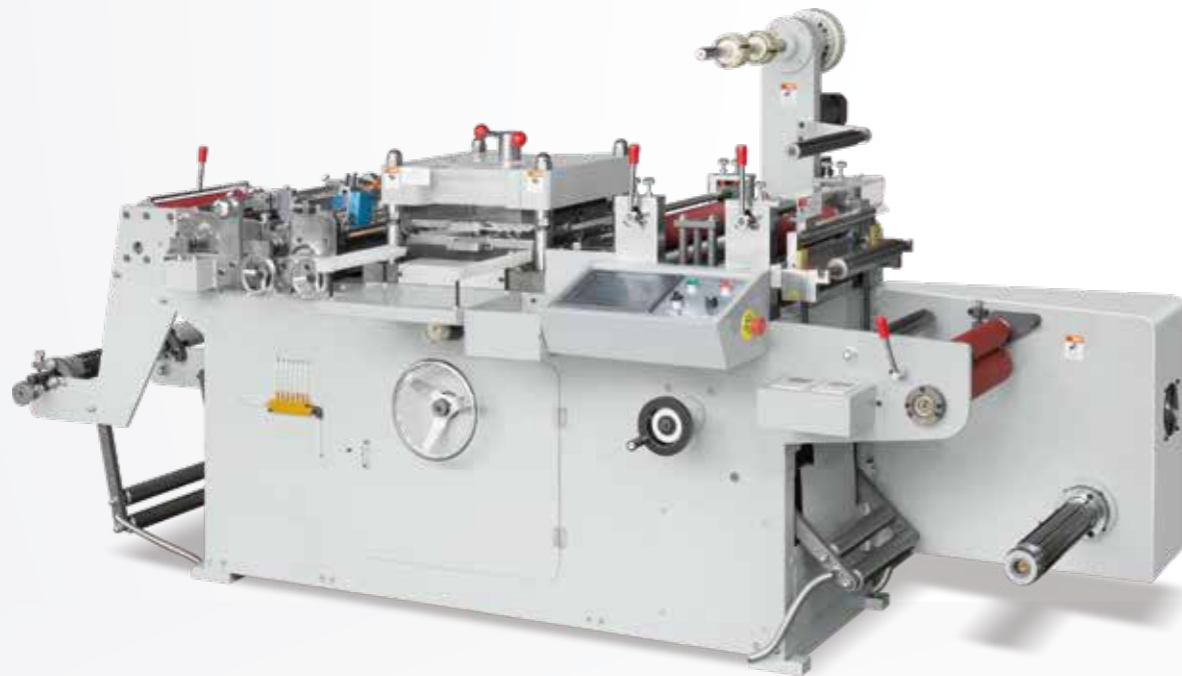

Characteristics特点

LDC-A flat bed die cutting machine, can die-cut both blank label and printed label. With Independent rewinding motor and magnetic powder tension control system, automatic oiling device system, high precision die cutting, high speed, variety of processing such as lamination, hot stamping, sheeting slitting can be integrated in once process, it is perfect match with the label digital printing machine and other type printing machine.

LDC-A型平压平模切机是一款专业高速标签模切机，可模切空白和印刷标签，收卷独立电机与磁粉张力控制系统，自动加油装置系统。模切精度高，速度快，可实现多种加工工艺于一体，可增加覆膜、烫金、纵切、分切等功能，是数码印刷机和其他印刷机的完美搭档。

主要技术参数 Main Technical Parameter

Machine model	机器型号	LDC-350A	LDC-450A
Die cutting speed	模切速度	20-300times/min	20-300times/min
Max. unwinding diameter	最大放料直径	500mm	500mm
Max. material width	最大材料宽度	350mm	450mm
Max. die cutting width	最大模切宽度	350mm	450mm
Max. die cutting length	最大模切长度	350mm	450mm
Positioning precision	定位精度	±0.1mm	±0.1mm

注：由于产品不断改进，机器外形及技术参数如有更改，恕不另行通知。
Note: as the products are developing day by day, the technical data are subject to change without notice.

HC-350B/450B

Label Turret Slitting Die Cutting Machine 标签模切分切机

Characteristics特点

This machine is the most economical type for narrow web blank label slitting and die cutting. Equipped with turret rewriter, automatic meter & number counting, web guiding device, auto tension control, which all assure the machine running friendly and efficiently.

本机是窄幅空白标签分切模切最经济的机型。机器配有旋转收卷，自动计米，自动计数功能，纠偏功能和自动张力控制，确保机器运行平稳高效。

Advantages优势

- Turret rewriter
- 1", 1.5", 3" pneumatic shaft are available
- Die cutting speed 120m/min
- Simulation web guide
- Can cut labels with thin liners reach to 40gsm
- 2 rotary die cutting station as option

优势

- 收卷自动旋转
- 1", 1.5", 3" 气胀轴可用于收卷
- 模切速度120m/min
- 模拟纠偏
- 可模切底纸最薄40gsm
- 选配：双工位模切



Blank label

主要技术参数 Main Technical Parameter

Machine model	机器型号	HC-350B	HC-450B
Slitting speed	分切速度	120m/min	120m/min
Die cutting speed	模切速度	120m/min	120m/min
Unwinding width	进料宽度	350mm	450mm
Rewinding diameter (1 roller)	收料直径 (1轴)	Φ480mm	Φ480mm
Rewinding diameter(2 rollers)	收卷直径 (2轴旋转)	Φ220mm	Φ220mm
Precision	机器精度	±0.15mm	±0.15mm
Total power	总功率	2.5kw	2.5kw

注：由于产品不断改进，机器外形及技术参数如有更改，恕不另行通知。
Note: as the products are developing day by day, the technical data are subject to change without notice.

HC-320/420/520

Narrow Web Slitting Rewinding Machine 窄幅分切复卷机

Application应用

This type machine is the most economical model for paper, film, label, etc. small rolls slitting and rewinding.

本机是纸张、薄膜、标签等小卷材料分切、复卷最经济的机型。

主要技术参数 Main Technical Parameter

Model model	机器型号	HC-320	HC-420	HC-520
Unwinding width	放料宽度	320mm	420mm	520mm
Unwinding diameter	放料直径	500mm	500mm	500mm
Rewinding diameter	收卷直径	480mm	500mm	500mm
Machine speed	机器速度	120m/min	120m/min	120m/min

注：由于产品不断改进，机器外形及技术参数如有更改，恕不另行通知。
Note: as the products are developing day by day, the technical data are subject to change without notice.



LY-350

Plate Mounting Machine 贴版机

Application应用

LY-350 Plate Mounting Machine is the product developed towards the customers for wide flexo printing machines. They are mainly used to mount the printing resin plate on the printing cylinder. Machine including rack, plate operation desk, high-definition color video camera, driving mechanism of plate roller lifting gear motor, corresponding control system and other components.

LY-350贴版机是面向广大柔版印刷机客户开发的产品。它们主要用于将印刷树脂版安装在印版辊上。机器包括机架、贴版操作台、高清彩色摄像机、贴版辊升降减速电机驱动机构、相应的控制系统等部件。

主要技术参数 Main Technical Parameter

Model model	机器型号	LY-350
Effective Width of the Plate	有效宽度	350mm
Diameter of the Central Spindle	主轴直径	210mm
Precision of the Plate	贴版精度	Better than ± 0.1 mm
Resolution Ratio of the Camera Lens	相机镜头的分辨率	650 Line
Maximum Focal Length of the Camera Lens	相机镜头的最大焦距	70 Times
Gear Motor Drive	齿轮电机传动	300m/min (Plate Roller)

注：由于产品不断改进，机器外形及技术参数如有更改，恕不另行通知。
Note: as the products are developing day by day, the technical data are subject to change without notice.

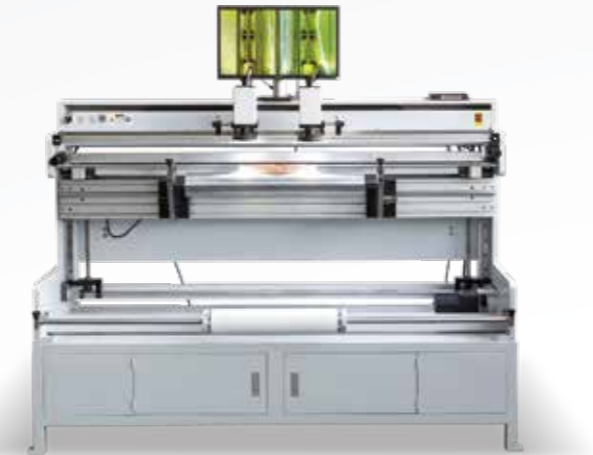

LY-450B

Inspection Rewinding Machine 检标复卷机

Application应用

This type machine is mainly used for rewinding various types of labels.

这种机器主要用于复卷各种类型的标签。

主要技术参数 Main Technical Parameter

Machine model	机器型号	LY-450 B
Rewind/unwind shaft height	收放卷轴高度	300mm
Rewind/unwind shaft diameter	收放卷轴直径	3inch
Maximum unwind/rewinding diameter	收放卷直径	450mm
Machine speed	机器速度	10-40m/min

注：由于产品不断改进，机器外形及技术参数如有更改，恕不另行通知。
Note: as the products are developing day by day, the technical data are subject to change without notice.



LY-500SC

Paper Core Cutting Machine 纸芯切割机

Application应用

This type machine is suitable for cutting paper cores, cutting different length as required.

这种机器适用于切割纸芯，根据需要切割不同长度。

主要技术参数 Main Technical Parameter

Machine model	机器型号	LY-500 SC
Paper core thickness	纸管厚度	≤ 10 mm
Core diameter	纸管直径	3inch
Max core length	最大纸管长度	2000mm

注：由于产品不断改进，机器外形及技术参数如有更改，恕不另行通知。
Note: as the products are developing day by day, the technical data are subject to change without notice.

