



Sistemas automatizados de manipulación de materiales a granel

Via Piana 67 Capocolle di Bertinoro Forlì Italy

www.technosilos.com



LÍNEAS COMPLETAS: plantas chocolate/dulces





LÍNEAS COMPLETAS: Ejemplo de P&ID

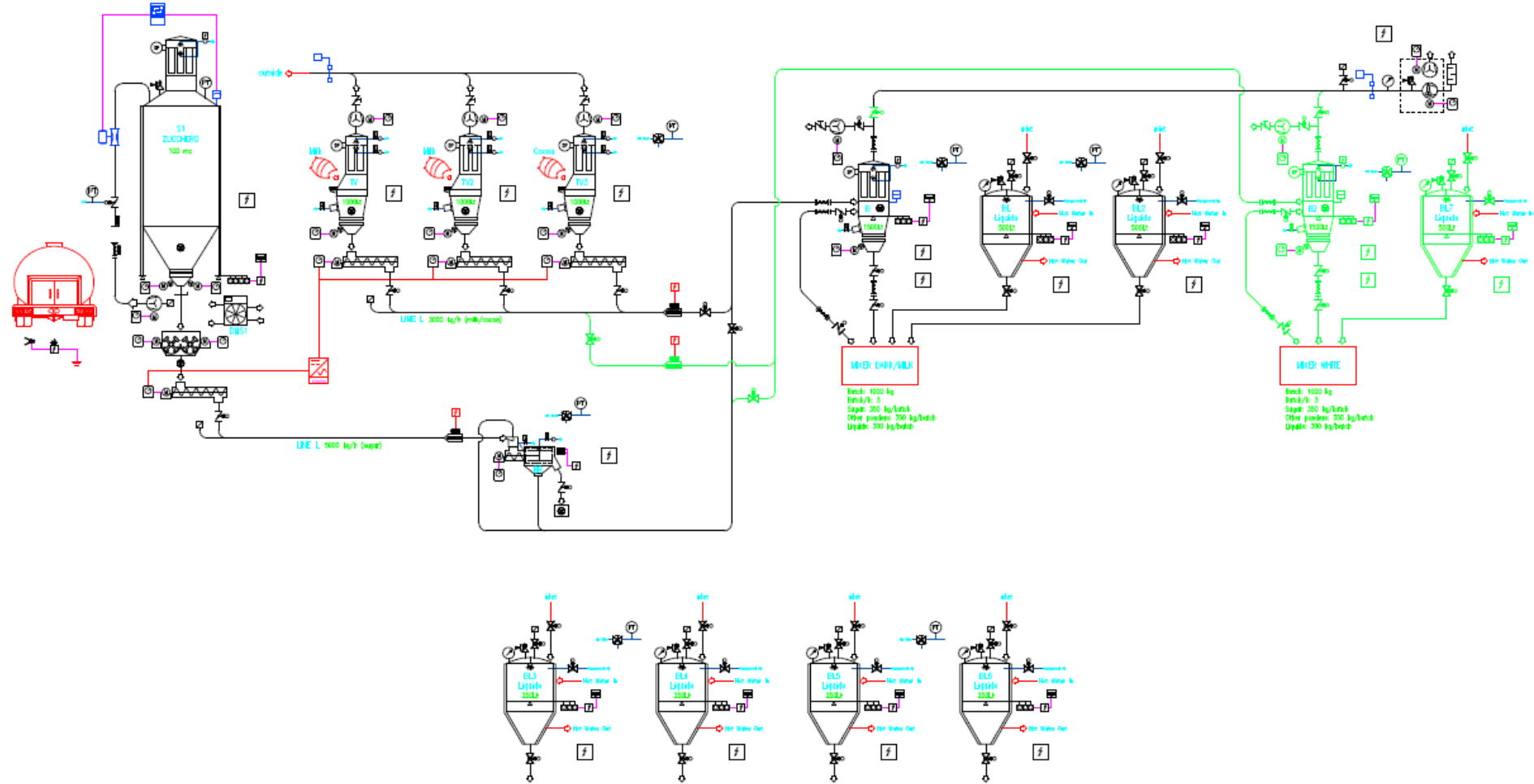



LÍNEAS COMPLETAS: Ejemplo de P&ID

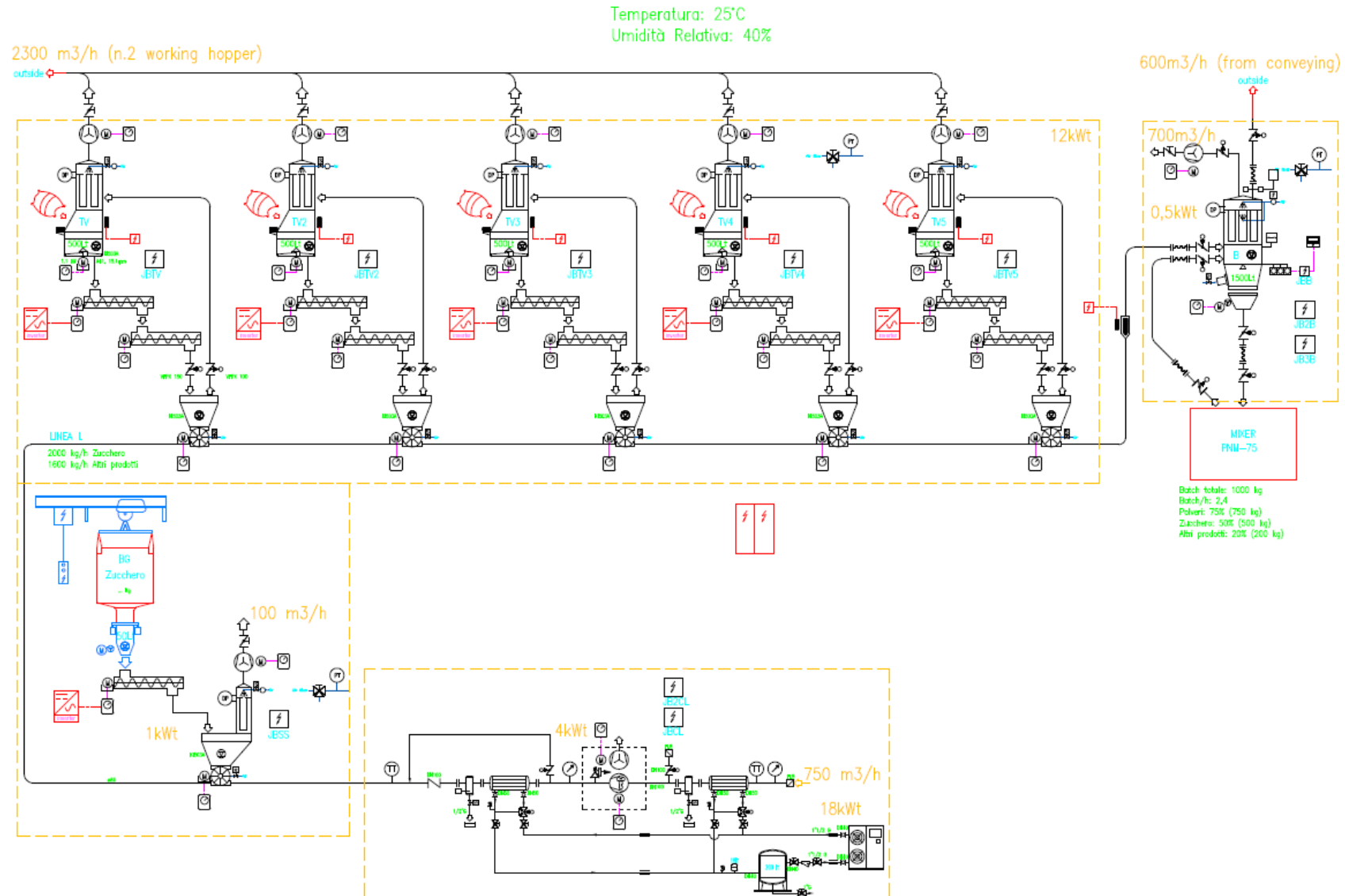



LÍNEAS COMPLETAS: Ejemplo de P&ID

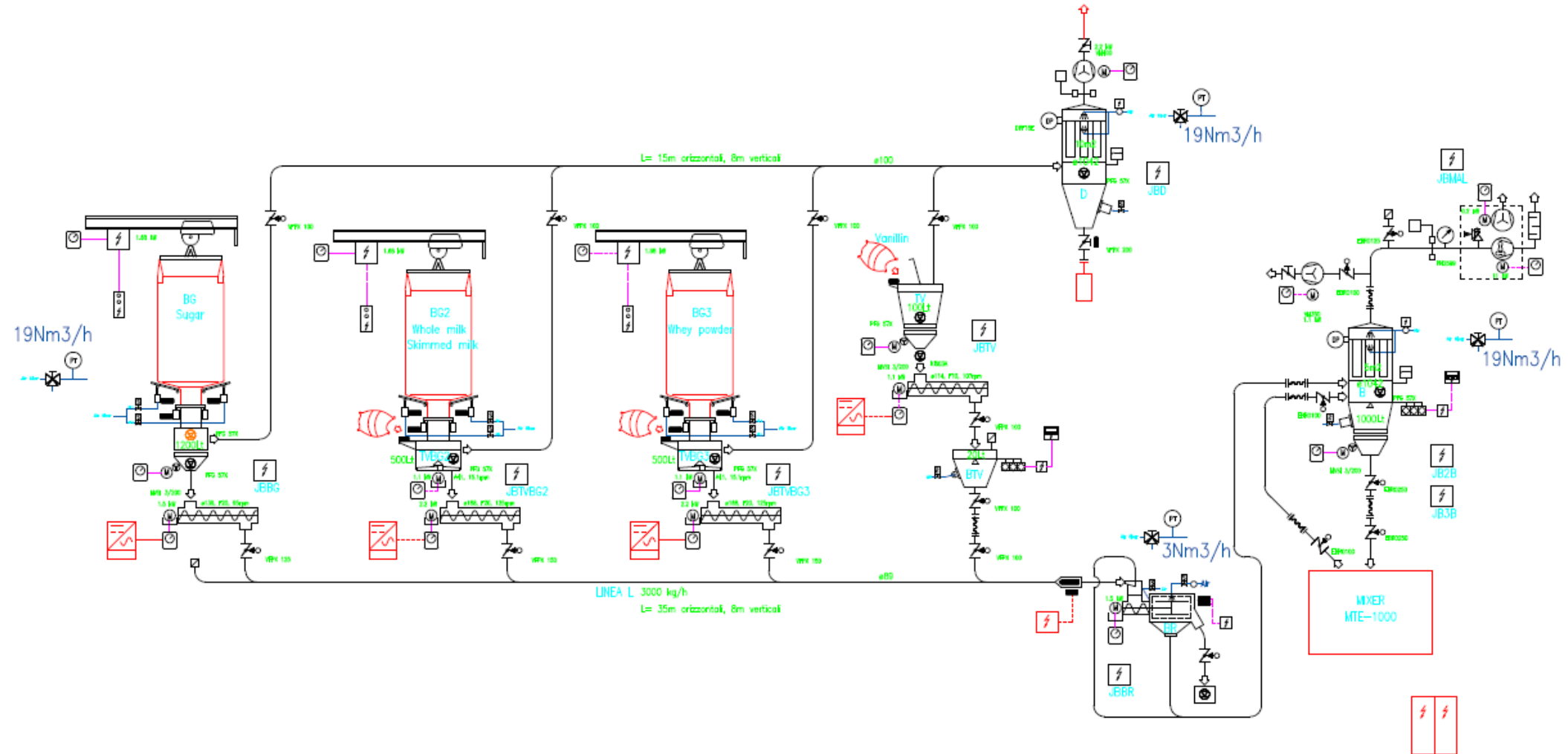



SOLUCIONES Y SERVICIOS

- Recepción de materias primas
- Silos de almacenamiento de ingredientes principales
- Tanques de almacenamiento de ingredientes principales
- Transporte
- Tamizado
- Molido (azúcar)
- Detección de piezas metálicas
- Dosificación de ingredientes principales y secundarios Raw Material Traceability
- Sistemas de mezcla
- Gestión automatizada de recetas
- PLC y sistema de control de supervisión y adquisición de datos (SCADA)
- Asistencia remota



LÍNEAS COMPLETAS: Esquema Funcional

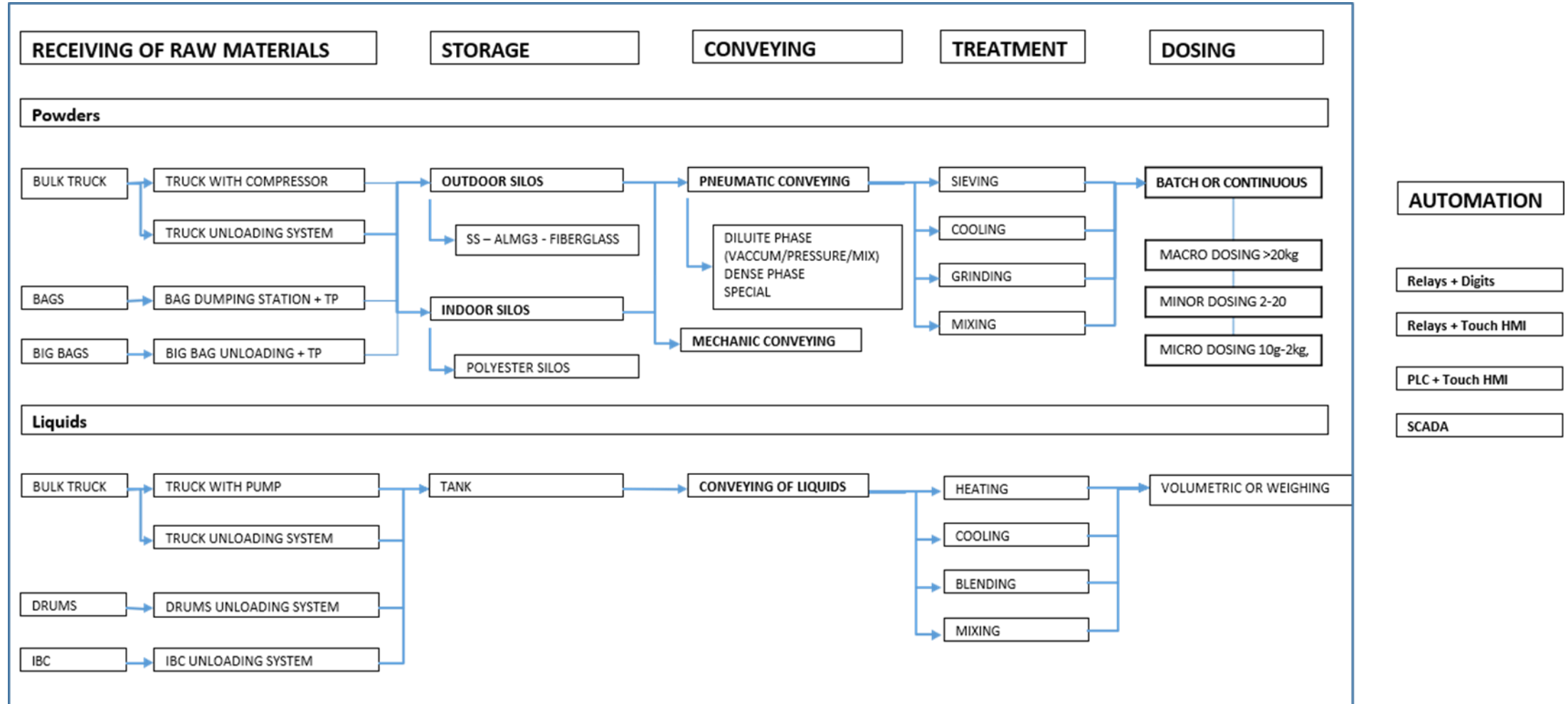

RECEPCIÓN Y ALMACENAMIENTO





Recepción de ingredientes primarios

ENTREGA A GRANEL

(incluyendo compresores para descarga de camiones cisterna)



SACOS

Estaciones de vaciado de sacos con o sin sistema de alimentación intermedia



BIG-BAGS

Estaciones de vaciado de big bags con o sin sistema de alimentación intermedia





Silos de almacenamiento



Exterior
(Acero Inoxidable o Aluminio)



Interior (Lona)



Recepción y almacenamiento de ingredientes menores



Estaciones de vaciado de sacos

Estaciones de vaciado de big-bag





Accesorios



Tamiz centrífugo



Tamiz vibratorio



Detector de metales con filtro magnético

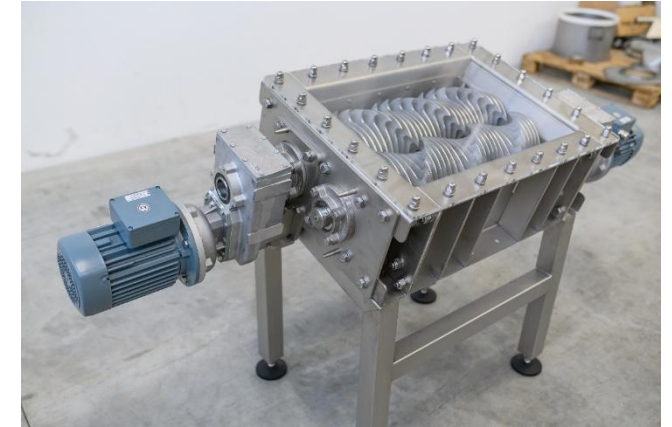

Rompedor de grumos



SISTEMAS DE DOSIFICACIÓN





Dosificación de ingredientes principales y secundarios

Sistemas de dosificación con filtro





Dosificación de ingredientes principales y secundarios

Sistemas de micro dosificación

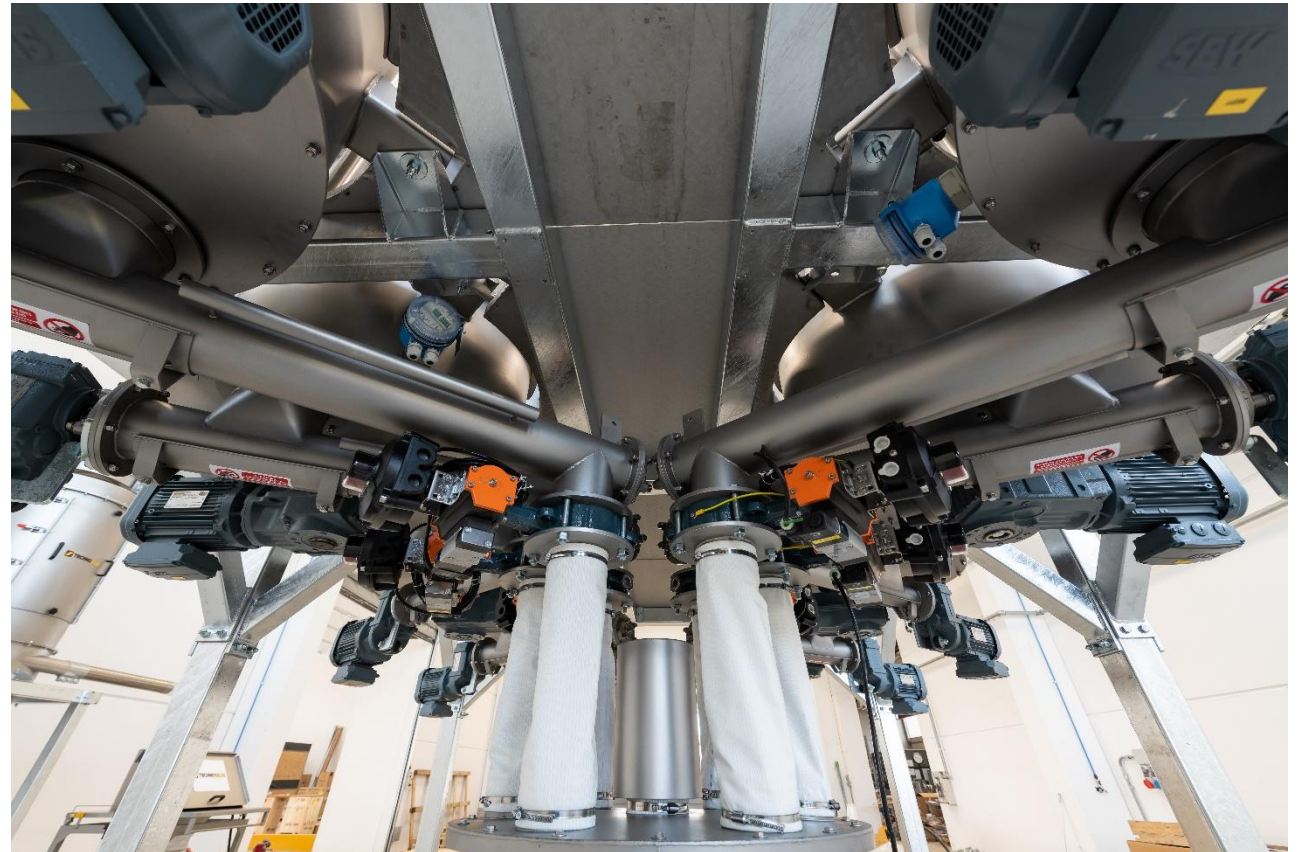



Dosificación de ingredientes principales y secundarios



Tanques con bombas



TRATAMIENTO Y PROCESAMIENTO





Mezclado



Mezclador
(con palas)

Mezclador
(con cintas)





Mezclado

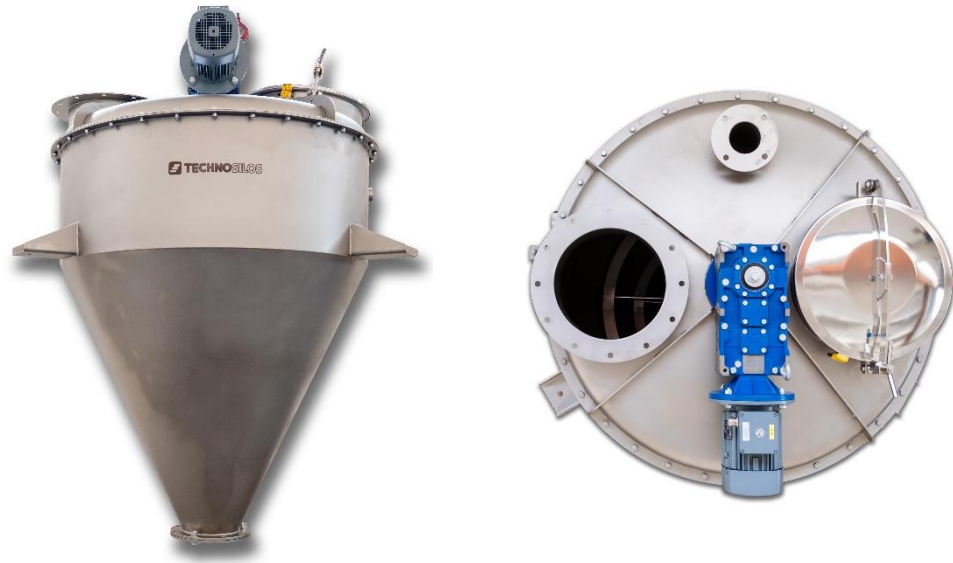

Mezclador





Accesorios

Molinos de Azúcar





Tratamiento de líquidos

- **Tanques de Almacenamiento**
- **Disolucionadore**
- **Fermentadores**
- **Descremadores**
- **Circuitos de Dosificación**
- **CIP**





Tratamiento de líquidos



Intercambiadores
de calor



Tanques de
preparación



AUTOMATIZACIÓN Y CONTROLES

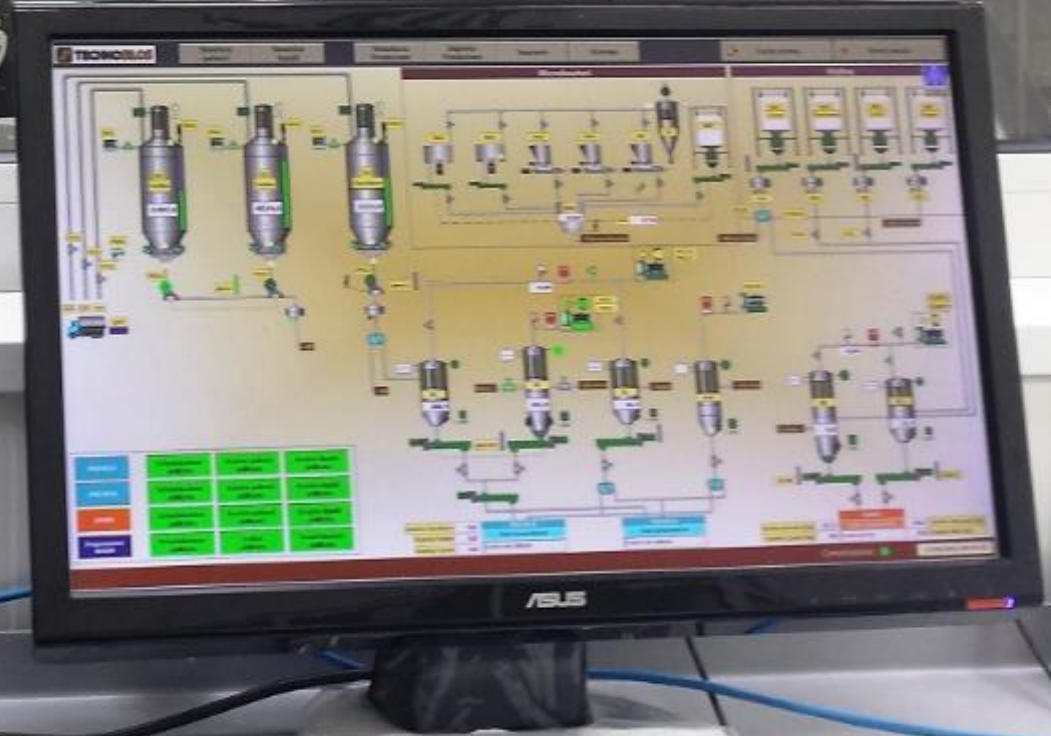
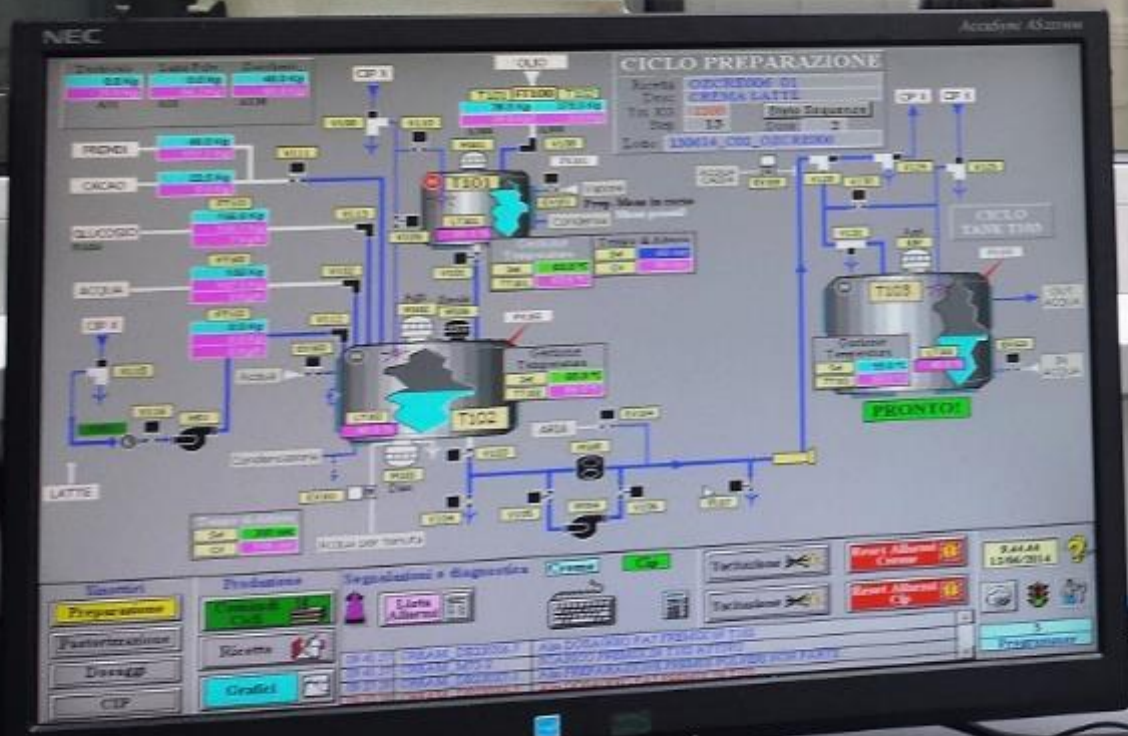



Automatización e interfaz hombre-máquina (HMI)

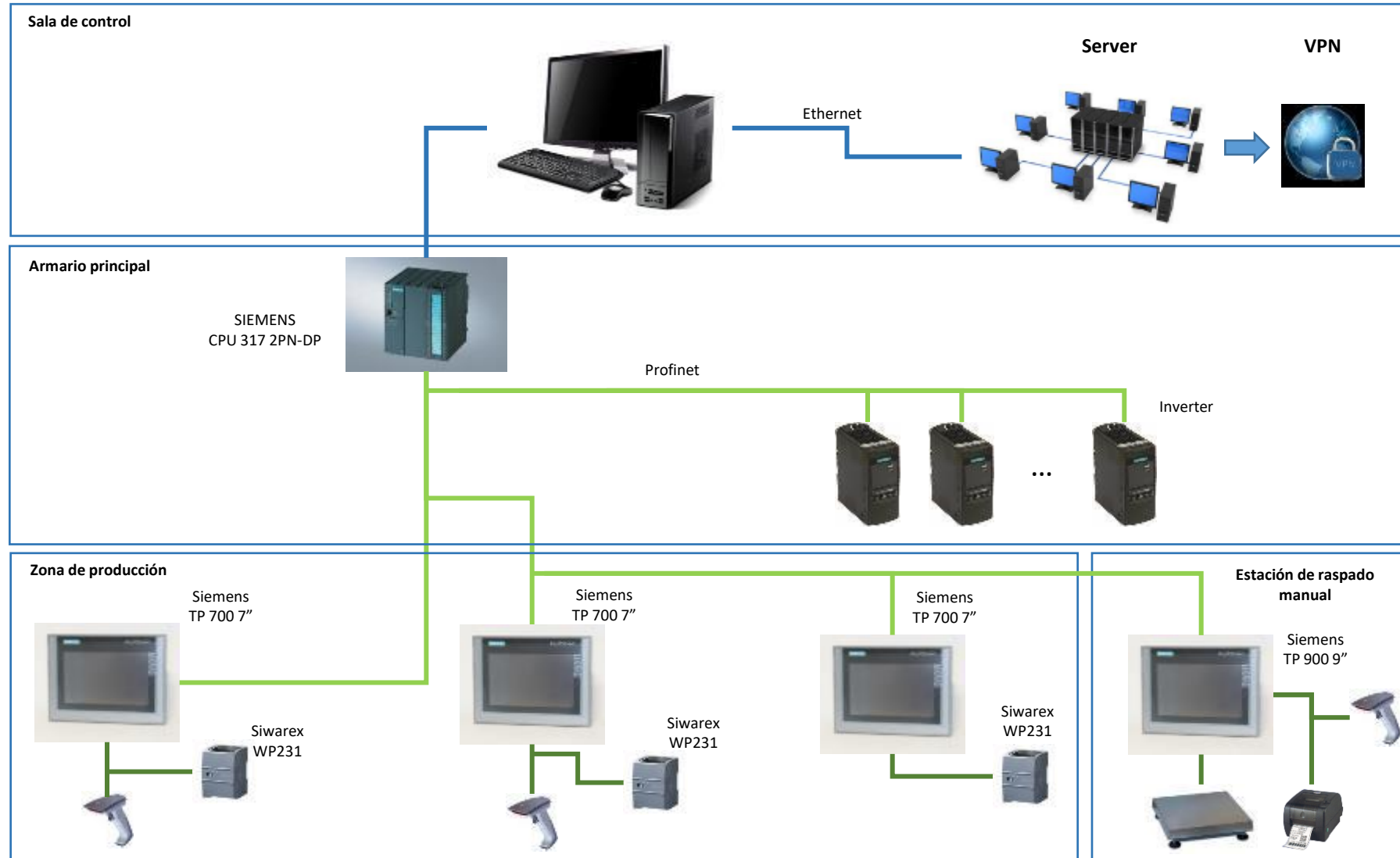

DUDAS?



Via Piana 67 Capocolle di Bertinoro Forlì Italy
www.technosilos.com