

R&R SUBSOILER

PARTS CATALOG

This catalog provides parts information for the following models:

____ R13MD, R16MD

____ R18-25MD

____ R13HD, R13-18HD

____ R13EHD, R13-18EHD

____ R17HD, R17-21HD

____ R17EHD, R17-21EHD, R17-26EHD

ISSUED MAY 1983
REVISED SEPT 2015

Stoess Manufacturing Inc

225 W. North Street
Washtucna, WA 99371
888-771-2314

Printed in the United States of America

MAJOR GROUP INDEX

INTRODUCTION

SECTION A

BEAM & TONGUE ASSEMBLY

SECTION B

SHANK ASSEMBLY

SECTION C

TOWER & LEG ASSEMBLY

SECTION D

HYDRAULICS

SECTION E

HYDRAULIC CYLINDERS

SECTION F

HUBS

SECTION G

PARKING STAND

SECTION H

Section A

INTRODUCTION AND GENERAL INFORMATION

This catalog contains a list of parts for R&R Subsoilers having a 7-digit serial number with the first three numbers being 448 or higher. However, if you are ordering parts for an earlier manufactured Subsoiler, this catalog may still be used as a guide. Most parts, but not all, shown in this catalog are compatible with earlier machines.

When ordering parts, it is very important to know your model # and serial #. They are located on the ID plate on the tongue near the front of your machine. The serial # is also stamped on the top of the connecting plates of the tongue and beam.

Whenever Subsoiler model numbers appear in this catalog, they are followed by the letters MD, HD, EHD, or SHD. These letters are the designation for Medium Duty, Heavy Duty, Extra Heavy Duty, or Super Heavy Duty, respectively. In earlier publications, these letter designations may or may not have appeared.

Once the model number is known, this catalog is used simply by reviewing the drawings of the major group that contains the desired part. The key number of the drawing is referenced to the part number. NOTE: Several parts may appear to be the same but may have more than one part number. This is because the material comprising the part will be different.

Several part numbers are determined by the size of the shank on your machine. The size of the shank is shown by the sketch below:

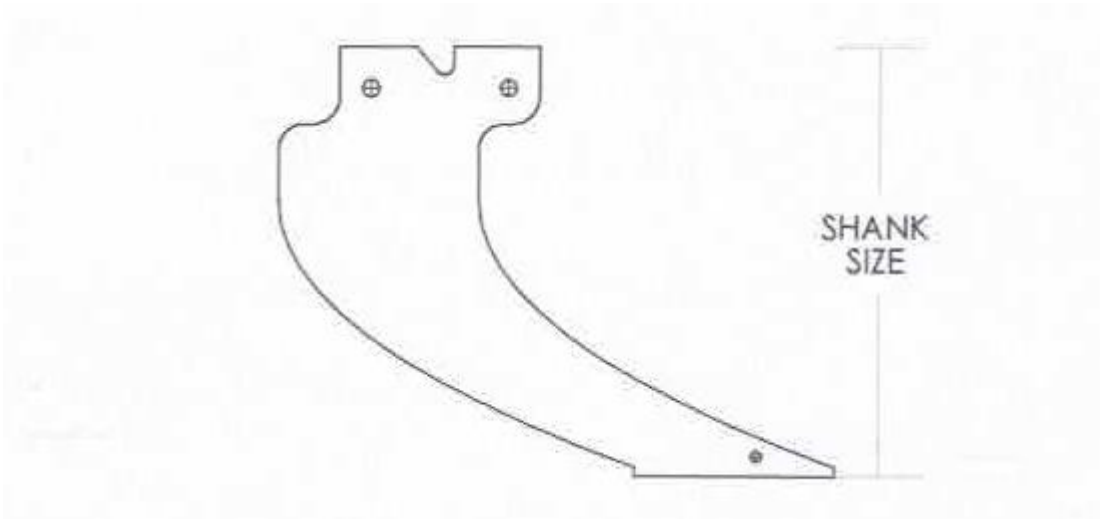

Several parts are designated left or right. The left or right side of the machine is determined by standing behind the machine facing the tractor. All bolts are National Course, Grade 8, unless otherwise specified.

It is important that you always use our factory made parts listed in the catalog. Over the years, we have developed a Subsoiler that is both strong and durable with an emphasis on productivity. Much of this development has occurred in the area of material selection and high quality fabrication. Keep your R&R Subsoiler operating at its fullest capability. When ordering parts for you Subsoiler, always use the R&R part number and description found in this catalog.

Section B

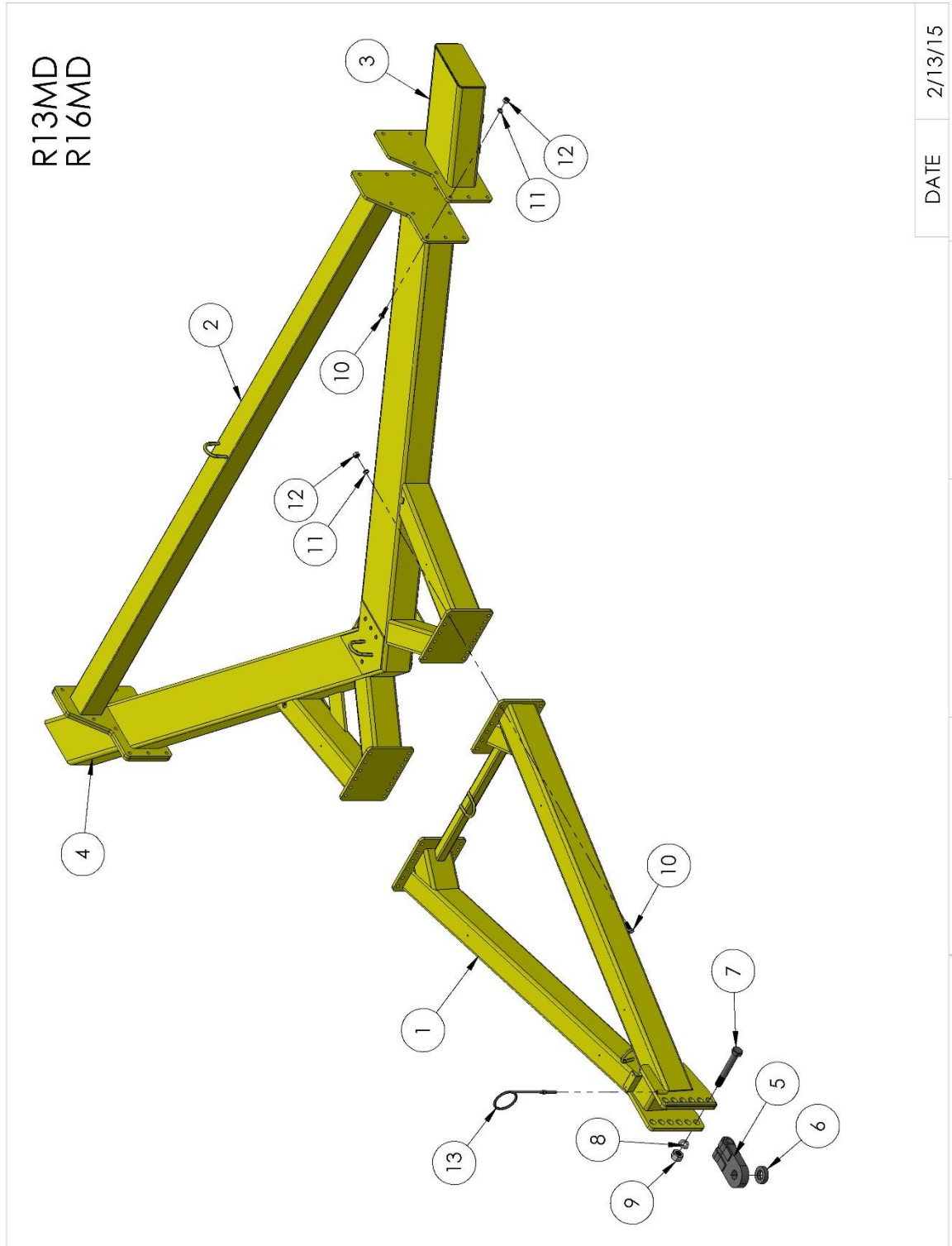

Section B

BEAM AND TONGUE ASSEMBLY R13MD R16MD

See page B1 for drawing

1	RPT113	Tongue
2	RPT114	Beam
3	RPT125LT	Wing, Left stub R16MD
4	RPT125RT	Wing, Right stub R16MD
5	RPT50 RPT50A	Flapper, standard Flapper with 1-1/2" -8 x 10-1/2" bolt, lock washer, and nut
6	RPT68	Flapper washer
7	FCSE1.5X10.5	Bolt, 1-1/2"-8 x 10-1/2"
8	FLW1.5	Lock washer, 1-1/2"
9	FNTH1.5	Nut, 1-1/2"-8 2H
10	FCSE.75x2.75	Cap screw, 3/4" x 2-3/4" Grd. 8
11	FLW.75	Lock washer, 3/4"
12	FNTH.75	Nut, 3/4" 2H
13	RPT45	Hydraulic loop
	FHPC.5	Hairpin clip (not shown)

Section B

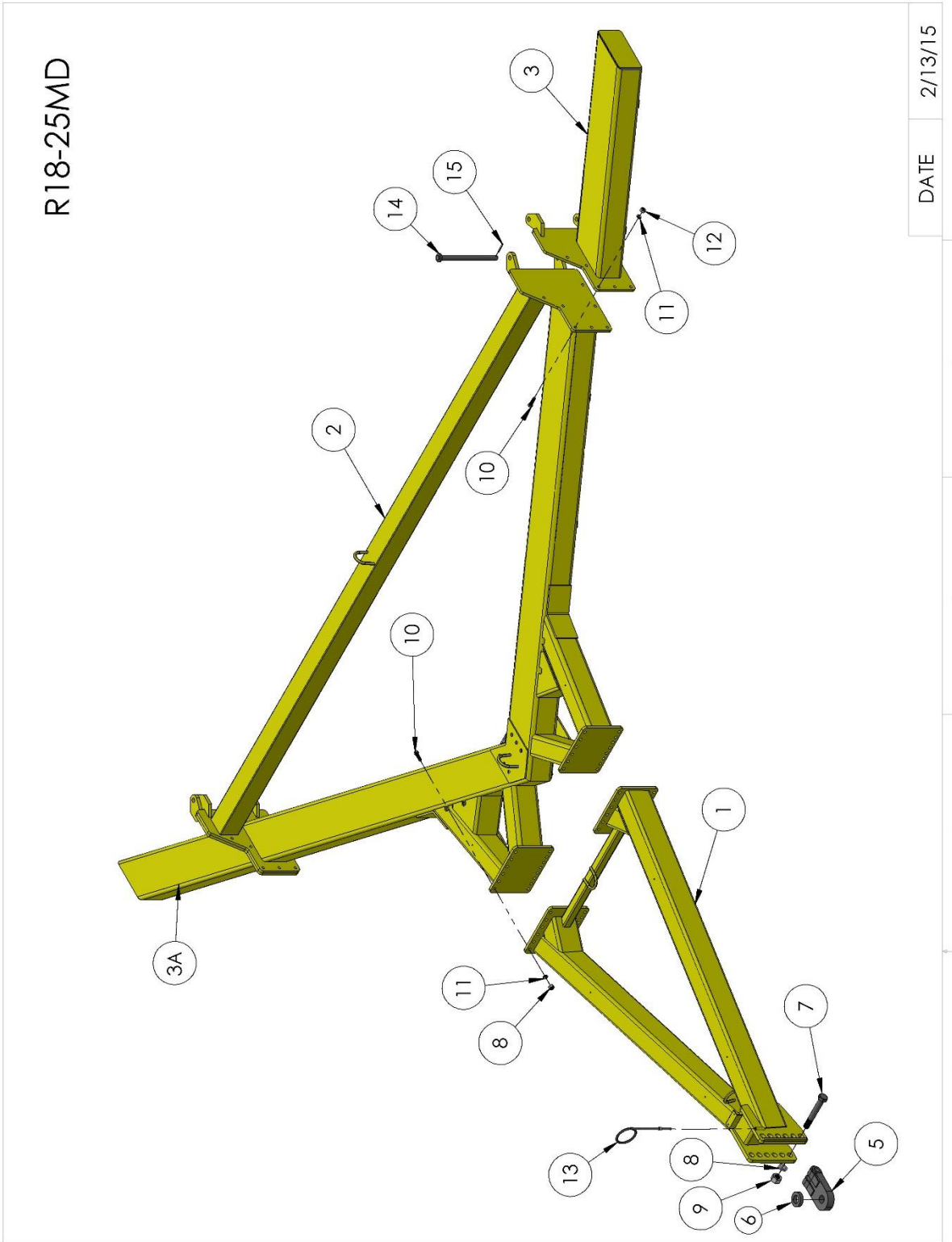

Section B 3

[BACK TO INDEX](#)

Section B

BEAM AND TONGUE ASSEMBLY

R18-25MD

See page B3 for drawing

1	RPT113A	Tongue
2	RPT181A	Beam
3	RPT183LT	Wing, Left stub R16MD
4	RPT183RT	Wing, Right stub R16MD
5	RPT50 RPT50A	Flapper, standard Flapper with 1-1/2 –8 x 10-1/2 bolt, lock washer, and nut
6	RPT68	Flapper washer
7	FCSE1.5X10.5	Bolt, 1-1/2"–8 x 10-1/2"
8	FLW1.5	Lock washer, 1-1/2"
9	FNTH1.5	Nut, 1-1/2"-8 2H
10	FCSE.75x2.75	Cap screw, 3/4" x 2-3/4" Grd. 8
11	FLW.75	Lock washer, 3/4"
12	FNTH.75	Nut, 3/4" 2H
13	RPT45 FHPC.5	Hydraulic loop Hairpin clip (not shown)
14	HCPT46	Hinge pin
15	FRP.313X2.5	Roll pin 5/16 X 2-1/2

Section B 4

[BACK TO INDEX](#)

Section B

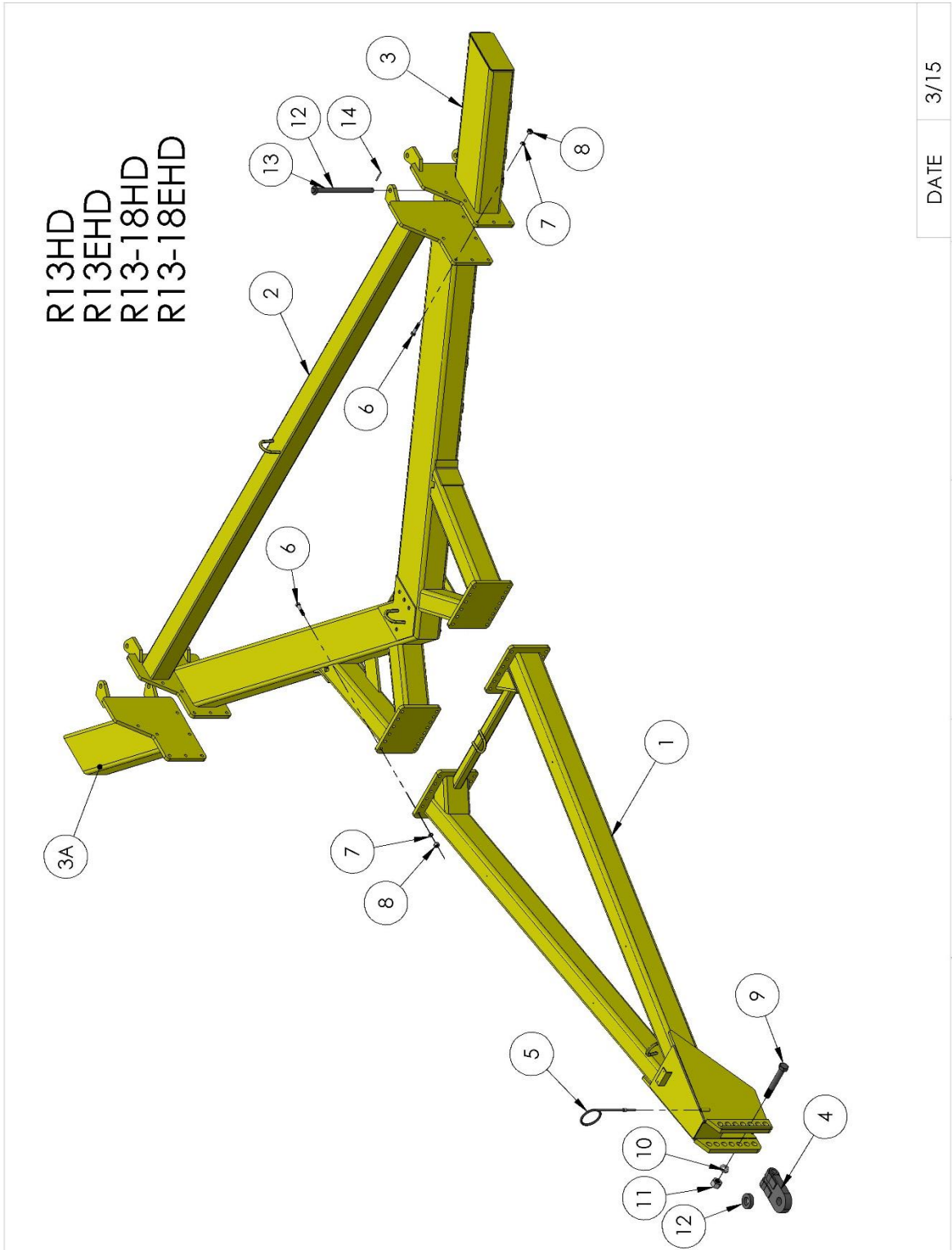

Section B 5

[BACK TO INDEX](#)

Section B

BEAM AND TONGUE ASSEMBLY R13HD & R13-18HD

See page B5 for drawing

1	RPT61	Tongue
2	RPT62	Beam, R13HD
3	RPT43	Wing, Left R13-18HD
3A	RPT44	Wing, Right R13-18HD
4	RPT50 RPT50A	Flapper Flapper with 1-1/2 –8 x 10-1/2 bolt, lock washer, and nut
5	RPT45 FHPC.5	Hydraulic loop Hairpin clip (not shown)
6	FCSE.75x2.75	Cap screw, 3/4" x 2-3/4" Grd. 8
7	FLW.75	Lock washer, 3/4"
8	FNTH.75	Nut, 3/4" 2H
9	FCSE1.5X10.5	Bolt, 1-1/2"–8 x 10-1/2"
10	FLW1.5	Lock washer, 1-1/2"
11	FNTH1.5	Nut, 1-1/2"-8 2H
12	RPT68	Flapper washer
13	RPT46	Hinge pin
14	FRP.313X2.5	Roll Pin, 5/16 x 2-1/2

Section B

BEAM AND TONGUE ASSEMBLY R13EHD & R13-18EHD

See page B5 for drawing

1	RPT129	Tongue
2	RPT130	Beam, R13HD
3	RPT43A	Wing, Left R13-18HD
3A	RPT44A	Wing, Right R13-18HD
4	RPT50 RPT50A	Flapper Flapper with 1-1/2 –8 x 10-1/2 bolt, lock washer, and nut
5	RPT45 FHPC.5	Hydraulic loop Hairpin clip (not shown)
6	FCSE.75X3.5	Cap screw, 3/4" x 3-1/2" Grd. 8
7	FLW.75	Lock washer, 3/4"
8	FNTH.75	Nut, 3/4" 2H
9	FCSE1.5X10.5	Bolt, 1-1/2"-8 x 10-1/2"
10	FLW1.5	Lock washer, 1-1/2"
11	FNTH1.5	Nut, 1-1/2"-8 2H
12	RPT68	Flapper washer
13	RPT46	Hinge pin
14	FRP.313X2.5	Roll Pin, 5/16 x 2-1/2

Section B

R17HD
R17-21HD

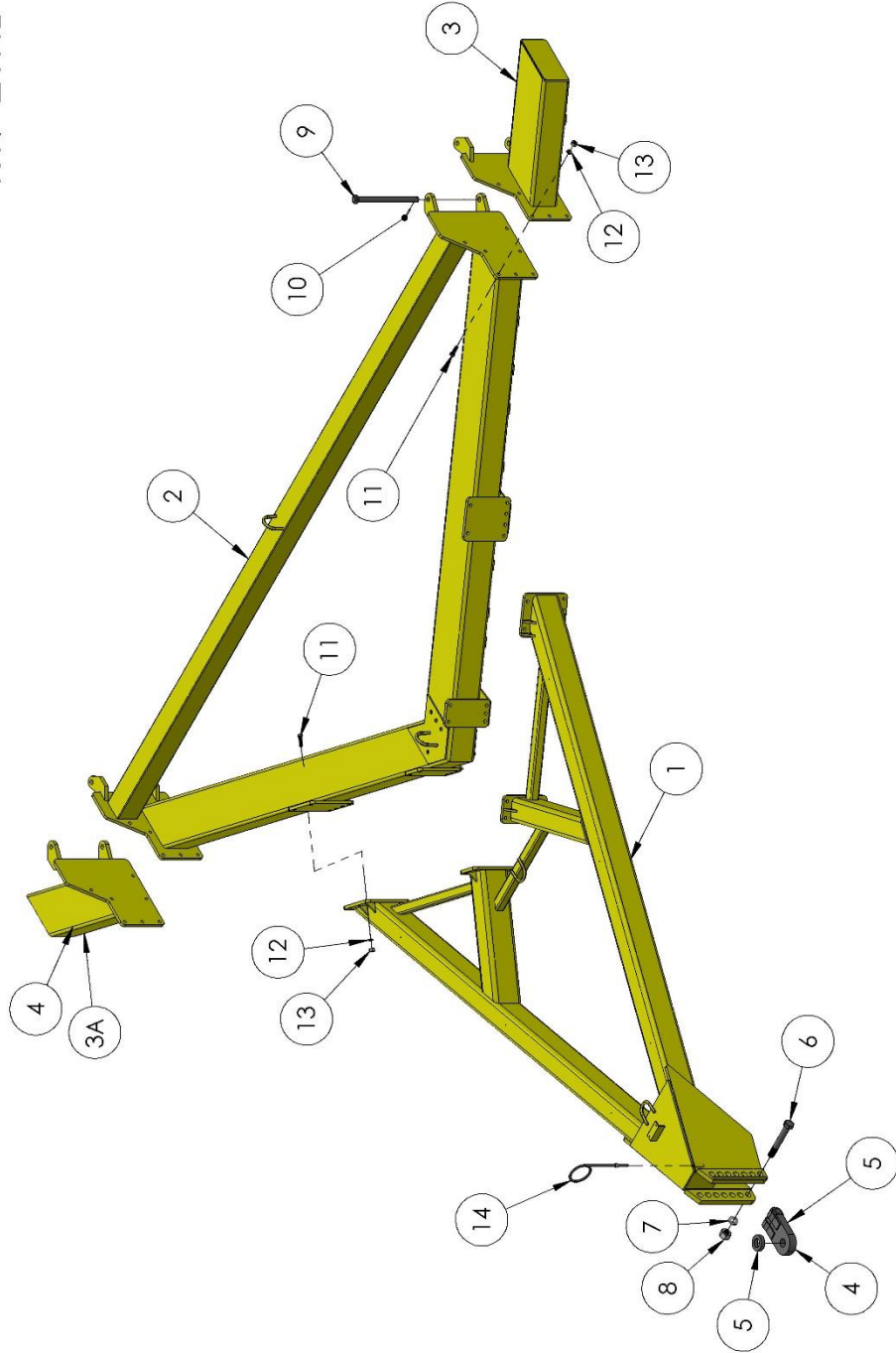

Section B

BEAM AND TONGUE ASSEMBLY R17HD & R17-21HD

See page B8 for drawing

1	RPT3	Tongue
2	RPT31	Beam
3	RPT54	Wing, Left
3A	RPT55	Wing, Right
4	RPT50 RPT50A	Flapper Flapper with 1-1/2 –8 x 10-1/2 bolt, lockwasher, and nut
5	RPT68	Flapper washer
6	FCSE1.5X10.5	Bolt, 1-1/2"–8 x 10-1/2"
7	FLW1.5	Lockwasher, 1-1/2"
8	FNTH1.5	Nut, 1-1/2"-8 2H
9	RPT46	Hinge pin
10	FRP.313X2.5	Roll Pin, 5/16 x 2-1/2
11	FCSE.75x2.75	Capscrew, 3/4" x 2-3/4" Grd. 8
12	FLW.75	Lockwasher, 3/4"
13	FNTH.75	Nut, 3/4" 2H
14	RPT45 FHPC.5	Hydraulic loop Hairpin clip (not shown)

Section B

R17EHD
R17-21EHD
R17-26EHD

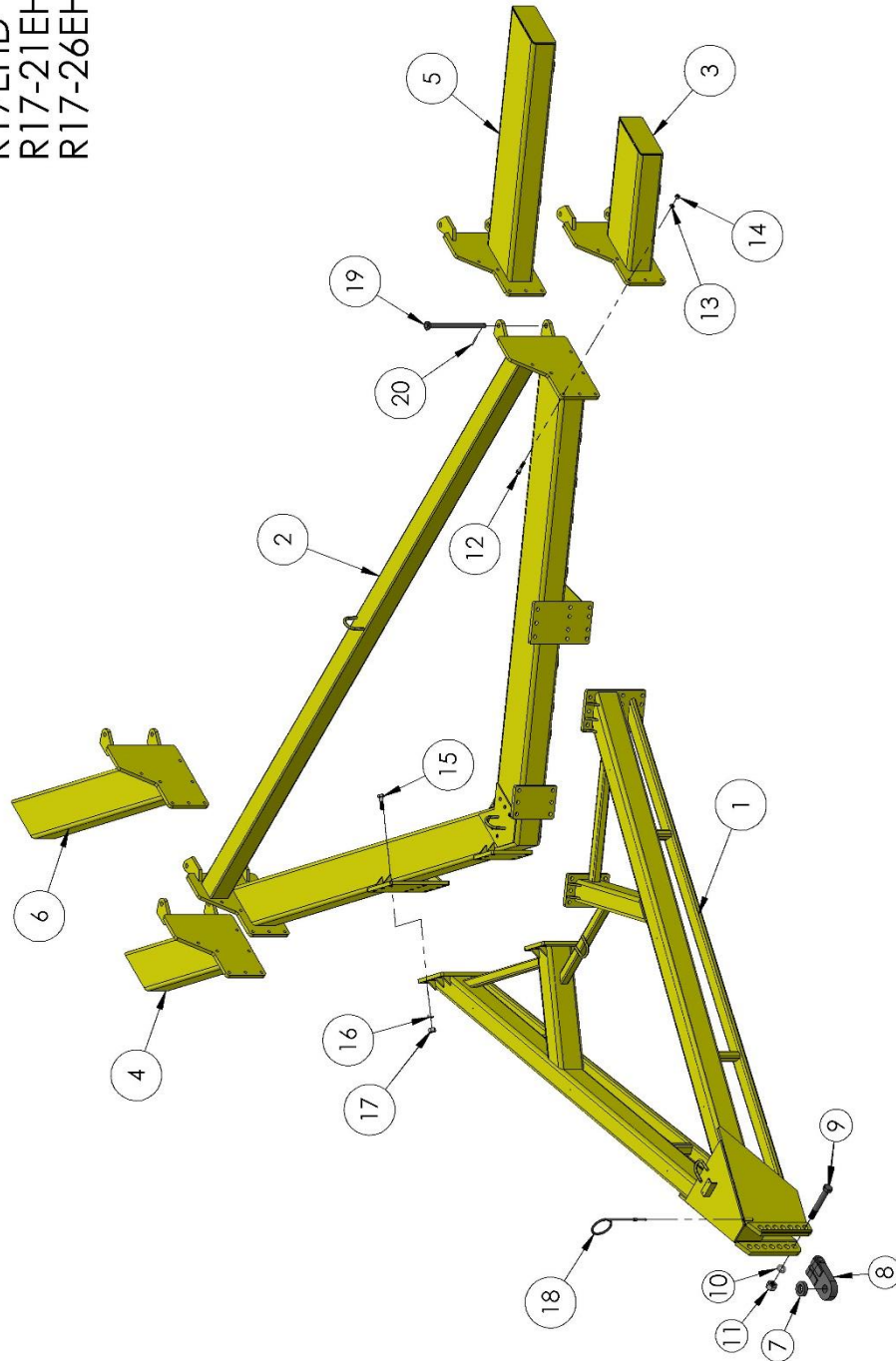

DATE	2/15
1	
2	
3	
4	
5	

Section B

BEAM AND TONGUE ASSEMBLY R17EHD & R21EHD & R26EHD

See page B10 for drawing

1	RPT126	Tongue, R17EHD
2	RPT128	Beam, R17EHD
3	RPT54A	Wing, Left R17-21EHD
4	RPT55A	Wing, Right R17-21EHD
5	RPT121	Wing, Left R17-26EHD
6	RPT122	Wing, Right R17-26EHD
7	RPT68	Flapper washer
8	RPT50	Flapper
	RPT50A	Flapper with 1-1/2 -8 x 10-1/2 bolt, lock washer, and nut
9	FCSE1.5X10.5	Bolt, 1-1/2"-8 x 10-1/2"
10	FLW1.5	Lockwasher, 1-1/2"
11	FNTH1.5	Nut, 1-1/2"-8 2H
12	FCSE1X3.5	Capscrew, 3/4" x 3-1/2" Grd. 8
13	FLW.75	Lockwasher, 3/4"
14	FNTH.75	Nut, 3/4" 2H
15	FCSE1x3.5	Capscrew, 1 x 3-1/2" Grd. 8
16	FLW1	Lockwasher, 1"
17	FNTH1	Nut, 1" 2H
18	RPT45	Hydraulic loop
	FHPC.5	Hairpin clip (not shown)
19	RPT46	Hinge pin, (2 req'd)
20	FRP.313X2.5	Roll Pin, 5/16 x 2-1/2

Section C

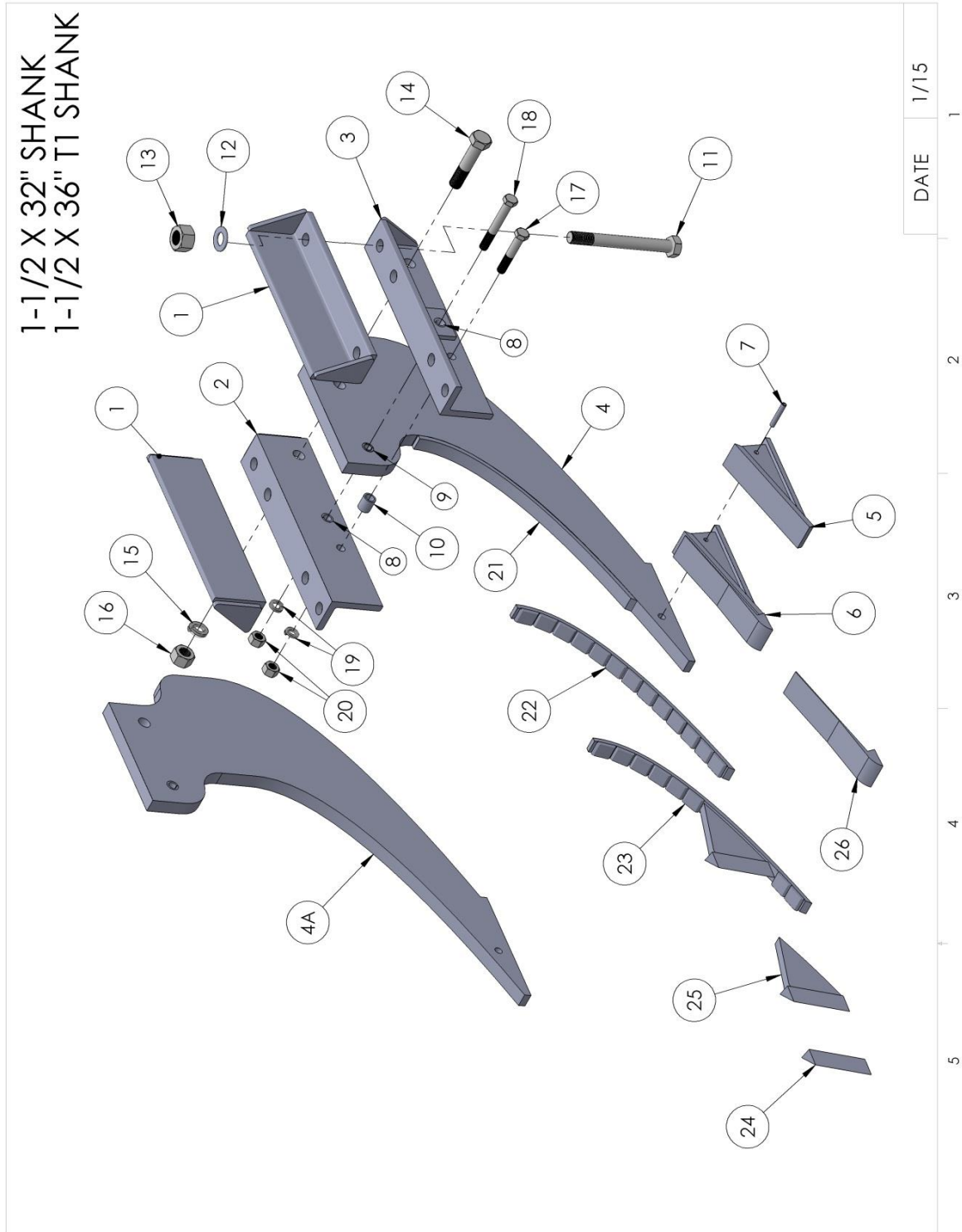

Section C

1-1/2" SHANK ASSEMBLIES

See page C1 for drawing

1	RPT152	Channel angle
2	RPT115ART	Shank Holder, Right
3	RPT115ALT	Shank Holder, Left
4	RPT117A	32" Shank with hard-faced wear strip
	RPT117H	32" Shank with chrome wear strip
	RPT117HC	32" Shank with chrome wear strip & clodsplitter
4A	RPT151A	36" Shank with hard-faced wear strip
	RPT151H	36" Shank with chrome wear strip
	RPT151HC	36" Shank with chrome wear strip & clod splitter
5	RSA3B	Shoe, T1, 1-1/2"
6	RPT17B	Shoe, chrome, 1-1/2"
7	FRP.5X3	Roll pin, 1/2 x 3
8	RC78A	Bushing, hardened, 1-1/4" (included in holders)
9	RC79A	Bushing, hardened, 1-1/2" (included in shank)
10	RPT119	Spacer, 1-1/2"
11	FCSF1.25X11.5	Cap screw, 1-1/4 X 11-1/2 NF Grd. 8
12	FCWA1.25	Flat washer, 1-1/4" A325
13	FNTF1.25	Nut, 1-1/4" NF, Grd. 8
14	FCSE1.25X6	Cap screw, 1-1/4" X 6" Grd. 8
15	FLW1.25	Lock washer, 1-1/4
16	FNTH1.25	Nut, 1-1/4"-8 2H
17	FCSE.875X5	Cap screw, 7/8" x 5" Grd. 8
18	FCSV.875X6.5	Shear bolt, 7/8" x 6-1/2" Grd. 5
19	FLW.875	Lock washer, 7/8
20	FNTH.875	Nut, 7/8" 2H
21	RPT136A	Hard-faced wear strip
22	RPT136H	Chrome wear strip
23	RPT136HC	Chrome wear strip with clod splitter
24	RC171	Chrome clod splitter wedge only
25	RPT177	Clod splitter with chrome wedge
26	ZZDYCOCHROME	Weld-on chrome top plate
27	RPT17BW	Shoe with wings (includes base shoe, chrome wings, fasteners)
28	RH98BWLT	Replaceable chrome left wing
29	RH98BWRT	Replaceable chrome right wing
30	FCSV.5X1.5	Capscrew, 1/2 x 1-1/2 (4 req per shoe)
31	FLW.5	Lockwasher, 1/2" (4 req per shoe)
32	FNT.5	Nut, 1/2" (4 req per shoe)

Section C

36" STANDARD SHANK

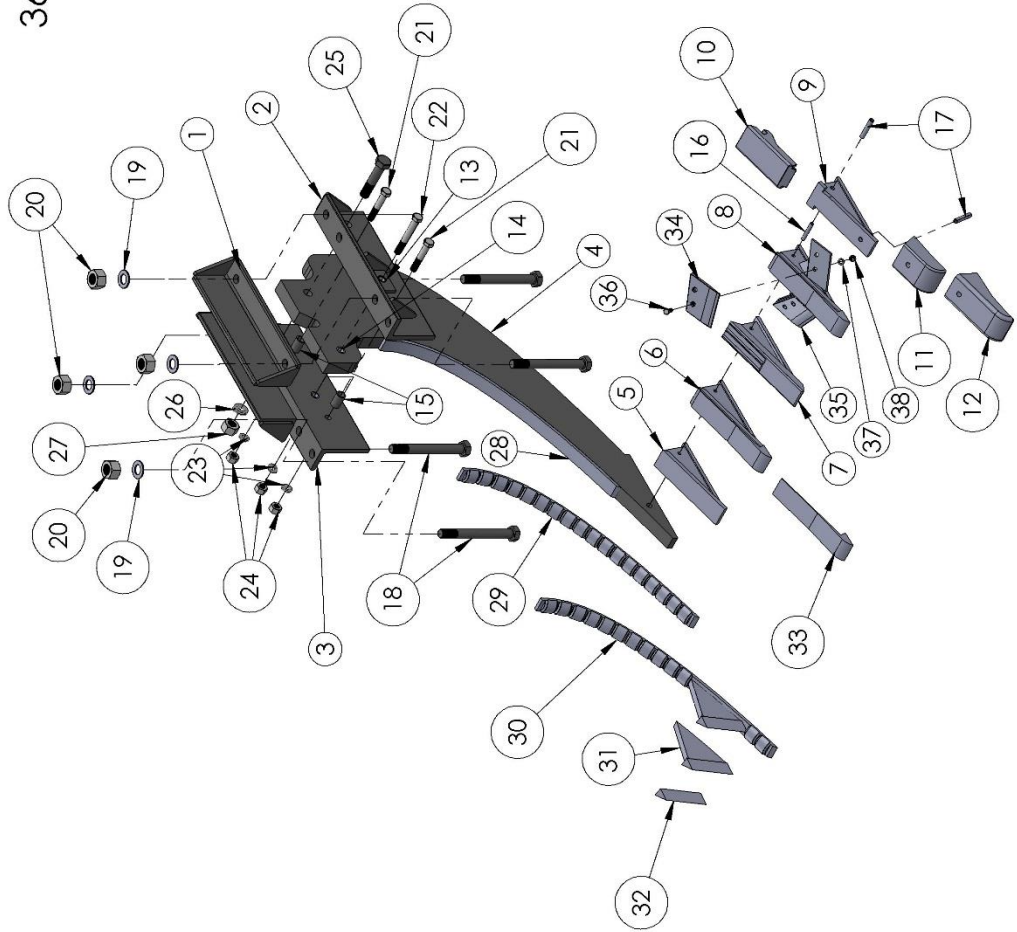

DATE 1/15

1 2 3 4 5

Section C

36" X 2" STANDARD SHANK ASSEMBLIES

See page C3 for drawing

1	RPT152	Channel angle
2	RPT52ALT	Shank Holder, Left 6 X 4 angle
	RPT153LT	Shank Holder, Left 8 X 4 angle
3	RPT52ART	Shank Holder, Right 6 X 4 angle
	RPT153RT	Shank Holder, Right 8 X 4 angle
4	RPT99A	36" Shank with hard-faced wear strip
	RPT99H	36" Shank with chrome wear strip
	RPT99HC	36" Shank with clod splitter & chrome wear strip
	RPT151A	36" T1 Shank with hard-faced wear strip
	RPT151H	36" T1 Shank with chrome wear strip
	RPT151HC	36" T1 Shank with clod splitter & chrome strip
5	RSA3	Shoe, T1, 2"
6	RPT17	Shoe, chrome, 2"
7	RSA3A	Shoe, Hard-faced, 2"
8	RPT17W	Shoe, with wings (includes base shoe, chrome wings and fasteners)
9	RSA3D	3-part shoe base
10	RC120	Chrome top plate
11	RC119	Chrome blunt nose
12	RC119A	Chrome sharp nose
	RPT163	Shoe, complete 3-part with blunt nose
	RPT163A	Shoe, complete 3-part with sharp nose
13	RC78A	Bushing, hardened, 1-1/4" (included in holders)
14	RC80A	Bushing, hardened, 2" (included in shank)

15	RPT29	Spacer, 2" (2 req'd)
16	FRP.5X3	Roll pin, 1/2 x 3
17	FRP.10X4	Roll pin, 5/8 x 3-1/2 (2 req'd) (Used only in 3 part shoes)
18	FCSF1.25X11.5	Cap screw, 1-1/4 X 11-1/2 NF Grd. 8 (4 req'd)
19	FCWA1.25	Flat washer, 1-1/4" A325 (4 req'd)
20	FNTF1.25	Nut, 1-1/4" NF, Grd. 8 (4 req'd)
21	FCSE.875X5	Cap screw, 7/8" x 5" Grd. 8 (2 req'd) tie bolts
22	FCSV.875X6.5	Shear bolt, 7/8" x 6-1/2" Grd. 5 shear bolt
	FCSE.875X6.5	Shear bolt, 7/8" x 6-1/2" Grd. 8 shear bolt
23	FLW.875	Lock washer, 7/8 (3 req'd)
24	FNTH.875	Nut, 7/8" 2H (3 req'd)
25	FCSE1.25X6	Cap screw, 1-1/4"-8 X 6" Grd. 8
26	FLW1.25	Lock washer, 1-1/4
27	FNTH1.25	Nut, 1-1/4"-8 2H
28	RPT87A	Hard-faced wear strip, 36"
29	RPT87H	Chrome wear strip, 36"
30	RPT87HC	Chrome wear strip with clod splitter, 36"
31	RPT177	Clod splitter with chrome wedge
32	RC171	Chrome clod splitter wedge only
33	ZZDYCOCHROME	Weld-on chrome top plate
34	RH98BWLT	Replaceable chrome left wing
35	RH98BWRT	Replaceable chrome right wing
36	FCSV.5X1.5	Cap screw, 1/2 x 1-1/2 Grd 5 (4 req. per shoe)
37	FLW.5	Lock washer, 1/2" (4 req. per shoe)
38	FNT.5	Nut, 1/2" (4 req. per shoe)

Section C

42" STANDARD SHANK

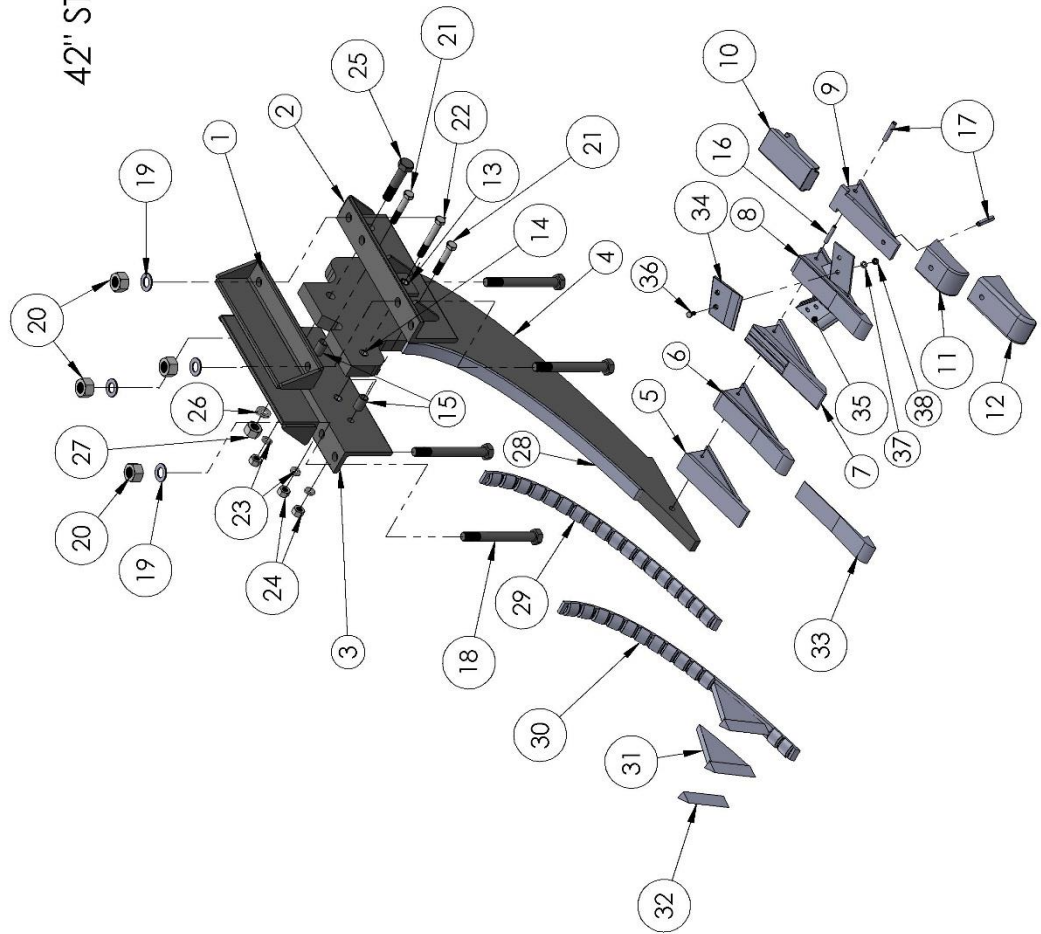

DATE 1/15

1

2

3

4

5

Section C 6

[BACK TO INDEX](#)

Section C

42" X 2" STANDARD SHANK ASSEMBLIES

See page C6 for drawing

1	RPT152	Channel angle
2	RPT153LT	Shank Holder, Left for 42" shanks
3	RPT153RT	Shank Holder, Right for 42" shanks
4	RPT14A	42" Shank with hard-faced wear strip
	RPT14H	42" Shank with chrome wear strip
	RPT14HC	42" Shank with clod splitter & chrome wear strip
	RPT69A	42" T1 Shank with hard-faced wear strip
	RPT69H	42" T1 Shank with chrome wear strip
	RPT69HC	42" T1 Shank with clod splitter & chrome strip
5	RSA3	Shoe, T1, 2"
6	RPT17	Shoe, chrome, 2"
7	RSA3A	Shoe, Hard-faced, 2"
8	RPT17W	Shoe, with wings (includes base shoe, chrome wings and fasteners)
9	RSA3D	3-part shoe base
10	RC120	Chrome top plate
11	RC119	Chrome blunt nose
12	RC119A	Chrome sharp nose
	RPT163	Shoe, complete 3-part with blunt nose
	RPT163A	Shoe, complete 3-part with sharp nose
13	RC78A	Bushing, hardened, 1-1/4" (included in holders)
14	RC80A	Bushing, hardened, 2" (included in shank)
15	RPT29	Spacer, 2" (2 req'd)
16	FRP.5X3	Roll pin, 1/2 x 3

17	FRP.10X4	Roll pin, 5/8 x 3-1/2 (2 req'd) (Used only in 3 part shoes)
18	FCSF1.25X11.5	Cap screw, 1-1/4 X 11-1/2 NF Grd. 8 (4 req'd)
19	FCWA1.25	Flat washer, 1-1/4" A325 (4 req'd)
20	FNTF1.25	Nut, 1-1/4" NF, Grd. 8 (4 req'd)
21	FCSE.875X5	Cap screw, 7/8" x 5" Grd. 8 (2 req'd) tie bolts
22	FCSV.875X6.5	Shear bolt, 7/8" x 6-1/2" Grd. 5 shear bolt
22	FCSE.875X6.5	Shear bolt, 7/8" x 6-1/2" Grd. 8 shear bolt
23	FLW.875	Lock washer, 7/8 (3 req'd)
24	FNTH.875	Nut, 7/8" 2H (3 req'd)
25	FCSE1.25X6	Cap screw, 1-1/4"-8 X 6" Grd. 8
26	FLW1.25	Lock washer, 1-1/4
27	FNTH1.25	Nut, 1-1/4"-8 2H
28	RPT53A	Hard-faced wear strip, 42
29	RPT53H	Chrome wear strip, 42"
30	RPT53HC	Chrome wear strip with clod splitter, 42"
31	RPT177	Clod splitter with chrome wedge
32	RC171	Chrome clod splitter wedge only
33	ZZDYCOCHROME	Weld-on chrome top plate
34	RH98BWLT	Replaceable chrome left wing
35	RH98BWRT	Replaceable chrome right wing
36	FCSV.5X1.5	Cap screw, 1/2 x 1-1/2 Grd 5 (4 req. per shoe)
37	FLW.5	Lock washer, 1/2" (4 req. per shoe)
38	FNT.5	Nut, 1/2" (4 req. per shoe)

Section C

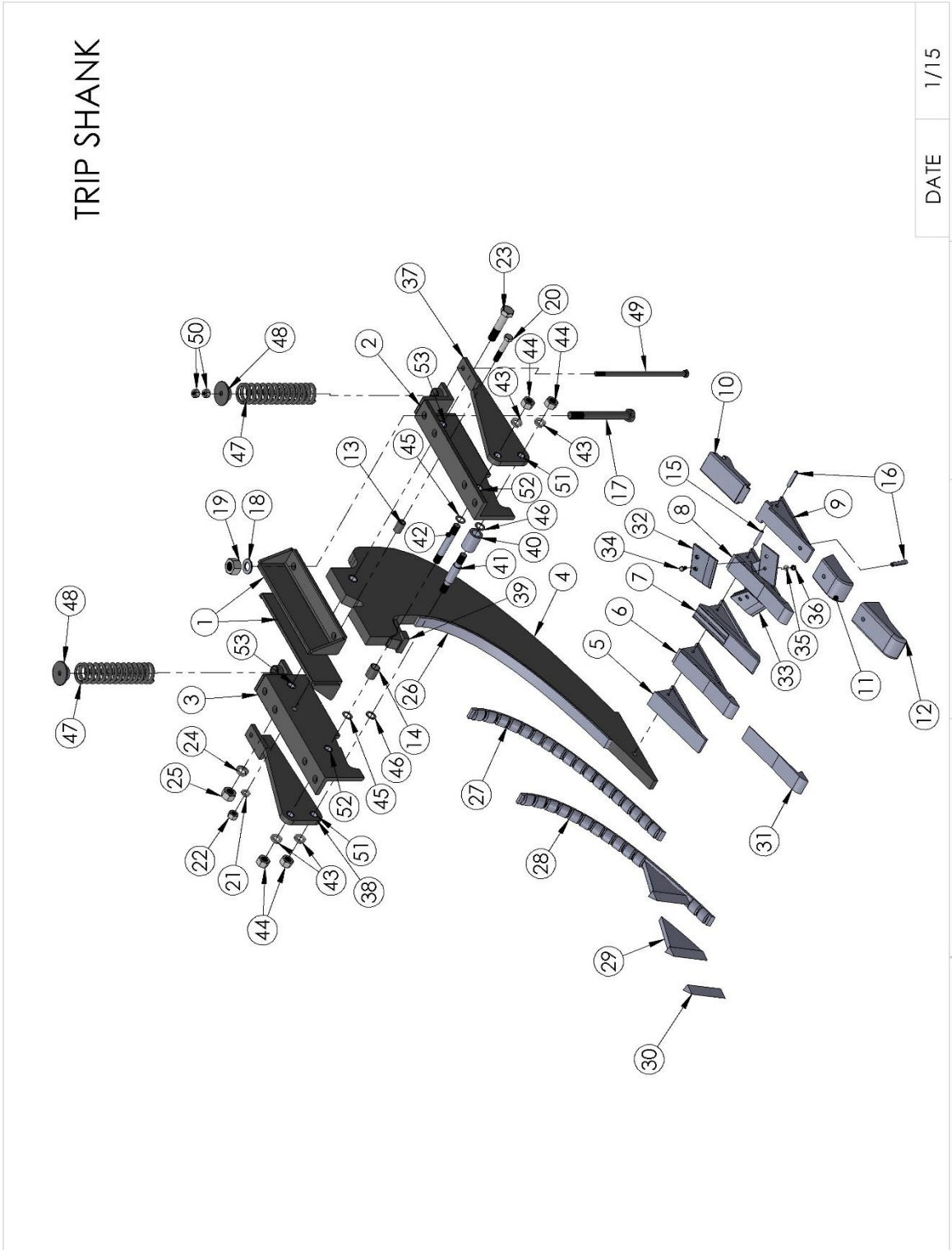

Section C

36" X 2" TRIP SHANK ASSEMBLIES

See page C9 for drawing

1	RPT152	Channel angle
2	RPT159LT	Trip Shank holder, Left
3	RPT159RT	Trip Shank holder, Right
4	RPT101A	36" Shank with hard-faced wear strip
	RPT101H	36" Shank with chrome wear strip
	RPT101HC	36" Shank with clod splitter & chrome wear strip
	RPT169A	36" T1 Shank with hard-faced wear strip
	RPT169H	36" T1 Shank with chrome wear strip
	RPT169HC	36" T1 Shank with clod splitter & chrome strip
4A	TB1.625X1.25X2	Bushing, hardened, 1-5/8 X 1-1/4 X 2 (included in Shank)
5	RSA3	Shoe, T1, 2"
6	RPT17	Shoe, chrome, 2"
7	RSA3A	Shoe, Hard-faced, 2"
8	RPT17W	Shoe, with wings (includes base shoe, chrome wings and fasteners)
9	RSA3D	3-part shoe base
10	RC120	Chrome top plate
11	RC119	Chrome blunt nose
12	RC119A	Chrome sharp nose
	RPT163	Shoe, complete 3-part with blunt nose
	RPT163A	Shoe, complete 3-part with sharp nose
13	RPT29	Spacer, 2" with 15/16" ID
14	RPT90	Spacer, 2" with 1-1/4" ID
15	FRP.5X3	Roll pin, 1/2 x 3
16	FRP.10X4	Roll pin, 5/8 x 3-1/2 (2 req'd) (Used only in 3 part shoes)
17	FCSF1.25X11.5	Cap screw, 1-1/4 X 11-1/2 NF Grd. 8
18	FCWA1.25	Flat washer, 1-1/4" A325
19	FNTF1.25	Nut, 1-1/4" NF, Grd. 8
20	FCSE.875X5	Cap screw, 7/8" x 5" Grd. 8 tie bolt
21	FLW.875	Lock washer, 7/8
22	FNTH.875	Nut, 7/8" 2H

23	FCSE1.25X6	Cap screw, 1-1/4"-8 X 6" Grd. 8
24	FLW1.25	Lock washer, 1-1/4
25	FNTH1.25	Nut, 1-1/4"-8 2H
26	RPT53A	Hard-faced wear strip, 36"
27	RPT53H	Chrome wear strip, 36"
28	RPT53HC	Chrome wear strip with clod splitter, 36"
29	RPT177	Clod splitter with chrome wedge
30	RC171	Chrome clod splitter wedge only
31	ZZDYCOCHROME	Weld-on chrome top plate
32	RH98BWL	Replaceable chrome left wing
33	RH98BWR	Replaceable chrome right wing
34	FCSV.5X1.5	Cap screw, 1/2 x 1-1/2 Grd 5 (4 req. per shoe)
35	FLW.5	Lock washer, 1/2" (4 req. per shoe)
36	FNT.5	Nut, 1/2" (4 req. per shoe)
37	RPT160LT	Side plate, left
38	RPT160RT	Side plate, right
39	RSA100C	Trip Shank Trigger (included in shank)
40	RC65	Roller, hardened
41	RC57A	Shoulder bolt with zerk
42	RC58	Stud bolt
43	FLW1.125	Lock washer, 1-1/8"
44	FNTH1.125	Nut, 1-1/8-8 2H
45	TWTRA-1828	Torrington Washer, 1/32"
46*	TWTRB-1828	Torrington Washer, 1/16"
47	RPT88	Spring
48	RPT91	Spring Cap
49	FCSE.75X18	Capscrew, 3/4 x 18"
50	FNTH.75	Nut, 3/4 2H
51	TB1.375X1.125X1	Bushing, 1-3/8 X 1-1/8 X 1 (incl. in side plates)
52	TB1.5X1.125X.75	Bushing, 1-1/2 X 1-1/8 X 3/4 (incl. in shank holders)
53	TB1.625X1.25X.7	Bushing, 1-5/8 X 1-1/4 X 3/4 (incl. in shank holders)

*NOTE: This item may need to be either a 1/32" or 1/16" Torrington washer.

Section C

42" X 2" TRIP SHANK ASSEMBLIES

See page C9 for drawing

1	RPT152	Channel angle
2	RPT159LT	Trip Shank holder, Left
3	RPT159RT	Trip Shank holder, Right
4	RPT96A	42" Shank with hard-faced wear strip
	RPT96H	42" Shank with chrome wear strip
	RPT96HC	42" Shank with clod splitter & chrome wear strip
	RPT102A	42" T1 Shank with hard-faced wear strip
	RPT102H	42" T1 Shank with chrome wear strip
	RPT102HC	42" T1 Shank with clod splitter & chrome strip
4A	TB1.625X1.25X2	Bushing, hardened, 1-5/8 X 1-1/4 X 2 (included in shank)
5	RSA3	Shoe, T1, 2"
6	RPT17	Shoe, chrome, 2"
7	RSA3A	Shoe, Hard-faced, 2"
8	RPT17W	Shoe, with wings (includes base shoe, chrome wings and fasteners)
9	RSA3D	3-part shoe base
10	RC120	Chrome top plate
11	RC119	Chrome blunt nose
12	RC119A	Chrome sharp nose
	RPT163	Shoe, complete 3-part with blunt nose
	RPT163A	Shoe, complete 3-part with sharp nose
13	RPT29	Spacer, 2" with 15/16" ID
14	RPT90	Spacer, 2" with 1-1/4" ID
15	FRP.5X3	Roll pin, 1/2 x 3
16	FRP.10X4	Roll pin, 5/8 x 3-1/2 (2 req'd) (Used only in 3 part shoes)
17	FCSF1.25X11.5	Cap screw, 1-1/4 X 11-1/2 NF Grd. 8
18	FCWA1.25	Flat washer, 1-1/4" A325
19	FNTF1.25	Nut, 1-1/4" NF, Grd. 8
20	FCSE.875X5	Cap screw, 7/8" x 5" Grd. 8 tie bolt
21	FLW.875	Lock washer, 7/8
22	FNTH.875	Nut, 7/8" 2H

23	FCSE1.25X6	Cap screw, 1-1/4"-8 X 6" Grd. 8
24	FLW1.25	Lock washer, 1-1/4
25	FNTH1.25	Nut, 1-1/4"-8 2H
26	RPT53A	Hard-faced wear strip, 42"
27	RPT53H	Chrome wear strip, 42"
28	RPT53HC	Chrome wear strip with clod splitter, 42"
29	RPT177	Clod splitter with chrome wedge
30	RC171	Chrome clod splitter wedge only
31	ZZDYCOCHROME	Weld-on chrome top plate
32	RH98BWL	Replaceable chrome left wing
33	RH98BWR	Replaceable chrome right wing
34	FCSV.5X1.5	Cap screw, 1/2 x 1-1/2 Grd 5 (4 req. per shoe)
35	FLW.5	Lock washer, 1/2" (4 req. per shoe)
36	FNT.5	Nut, 1/2" (4 req. per shoe)
37	RPT160LT	Side plate, left
38	RPT160RT	Side plate, right
39	RSA100C	Trip Shank Trigger (included in shank)
40	RC65	Roller, hardened
41	RC57A	Shoulder bolt with zerk
42	RC58	Stud bolt
43	FLW1.125	Lock washer, 1-1/8"
44	FNTH1.125	Nut, 1-1/8-8 2H
45	TWTRA-1828	Torrington Washer, 1/32"
46*	TWTRB-1828	Torrington Washer, 1/16"
47	RPT88	Spring
48	RPT91	Spring Cap
49	FCSE.75X18	Cap screw, 3/4 x 18"
50	FNTH.75	Nut, 3/4 2H
51	TB1.375X1.125X1	Bushing, 1-3/8 X 1-1/8 X 1 (incl. in side plates)
52	TB1.5X1.125X.75	Bushing, 1-1/2 X 1-1/8 X 3/4 (incl. in shank holders)
53	TB1.625X1.25X.7	Bushing, 1-5/8 x 1-1/4 X 3/4 (incl. in shank holders)

*NOTE: This item may need to be either a 1/32" or 1/16" Torrington washer

Section D

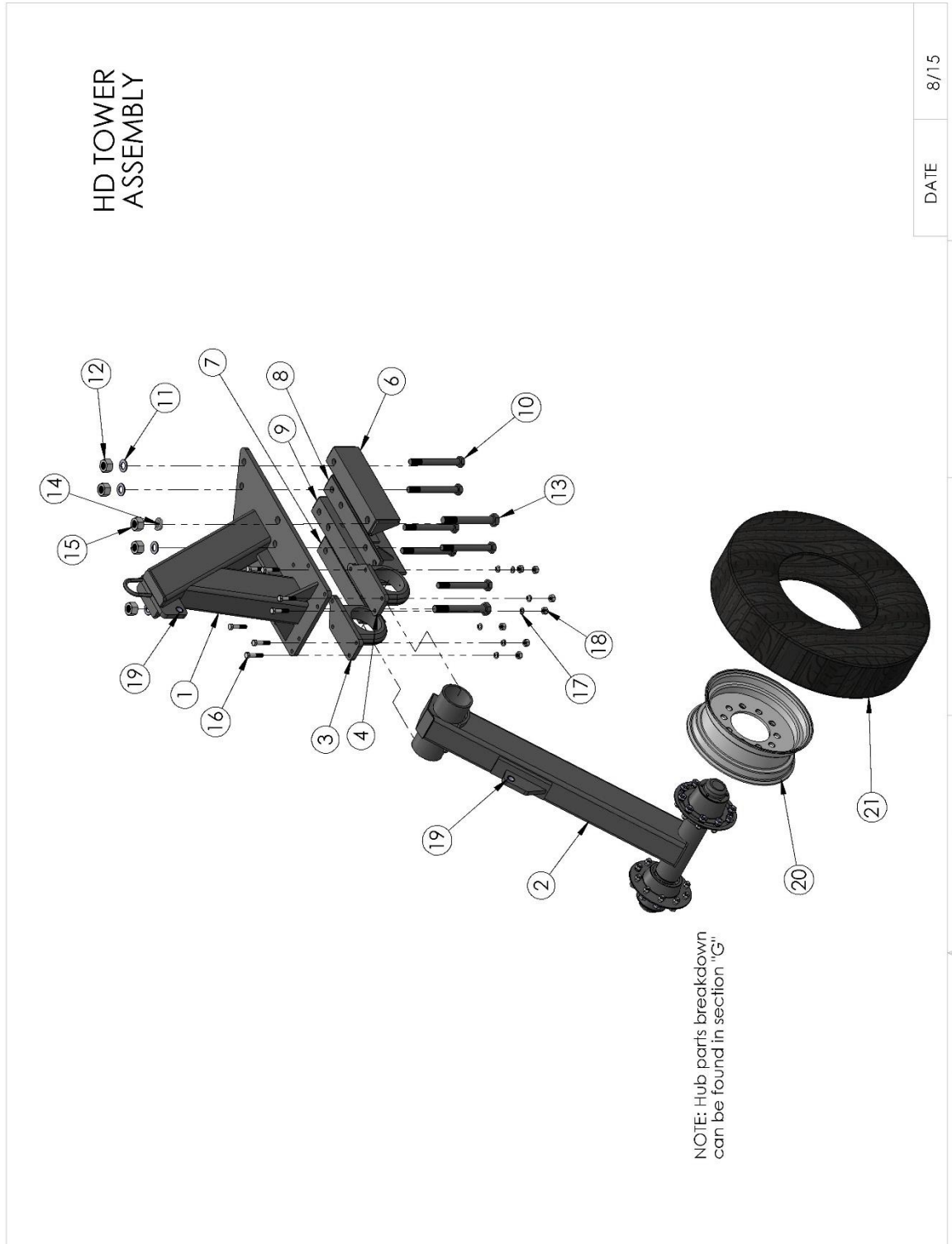

Section D

MD & HD TOWER AND LEG ASSEMBLY

See page D1 for drawing

1	RPT131BLT	Tower, Left
	RPT131BRT	Tower, Right (pictured)
2	RPT56	Leg for 36" shanks
	RPT51	Leg for 42" shanks
3	RPT20ART	Bearing, right
4	RPT20ALT	Bearing, left
6	RPT154LT	Tower Channel, Left
7	RPT154RT	Tower Channel, Right
8*		Left Shank Holder (See page "C")
9*		Right Shank Holder (See Page "C")
10	FCSF1.25X11.5	Capscrew, 1-1/4 x 11-1/2 NF
11	FCWA1.25	Flat cut washer, 1-1/4 A325
12	FNTF1.25	Nut, 1-1/4 NF
13	FCSF1.5X12	Capscrew, 1-1/2 x 12 NF
14	FLW1.5	Lockwasher, 1-1/2
15	FNTF1.5	Nut, 1-1/2 NF
16	FCSE.75X3.5	Capscrew, 3/4 x 3-1/2 grd. 8
17	FLW.75	Lockwasher, 3/4" (16 req'd/machine)
18	FNTH.75	Nut, 3/4" 2H (16 req'd/machine)
19	TB1.625X1.25X1	Bushing, 1-5/8 x 1-1/4 x 1 (included)
20	RWHP8.72X22	Wheel
21	RTIN11X22.5FS	Tire
	RPT57C	Mounted tire

**RPT40 Channel shim, 1/2 x 2 flat (Not shown)

* If there is no shank under the tower, use (2) RPT152

** In certain configurations, the outside RPT154LT or RT may sit half way on top of the shank aligning plate. If this occurs, use RPT40 to fill in the void between the beam and angle iron brkt.

Section D

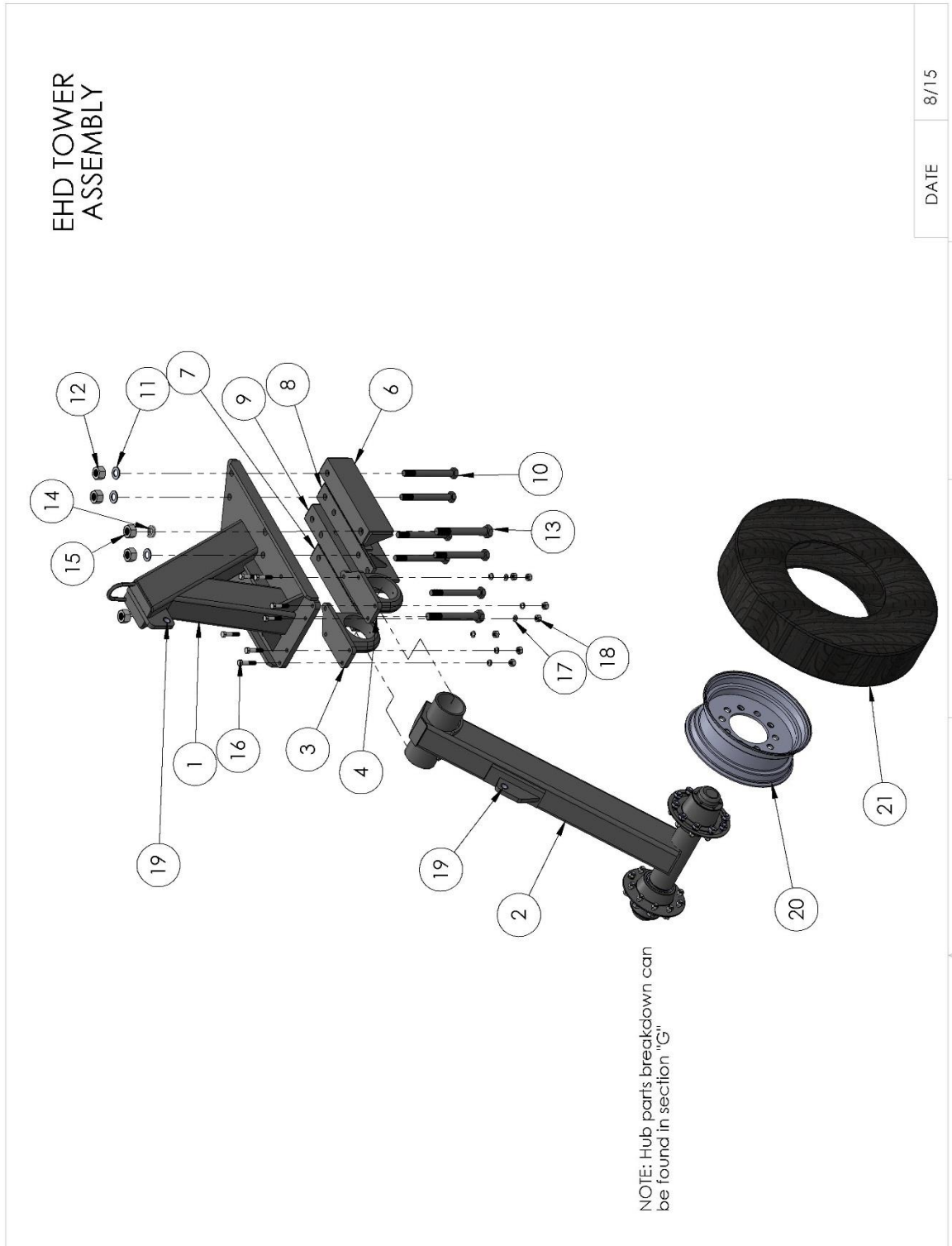

Section D

EHD & SHD TOWER AND LEG ASSEMBLY

See page D2 for drawing

1	RPT131CLT	Tower, Left
	RPT131CRT	Tower, Right (pictured)
2	RPT56	Leg for 36" shanks
	RPT51	Leg for 42" shanks
3	RPT20ART	Bearing, right
4	RPT20ALT	Bearing, left
6	RPT154LT	Tower Channel, Left
7	RPT154RT	Tower Channel, Right
8*		Left Shank Holder (See page "C")
9*		Right Shank Holder (See Page "C")
10	FCSF1.25X11.5	Capscrew, 1-1/4 x 11-1/2 NF
11	FCWA1.25	Flat cut washer, 1-1/4 A325
12	FNTF1.25	Nut, 1-1/4 NF
13	FCSF1.5X12	Capscrew, 1-1/2 x 12 NF
14	FLW1.5	Lockwasher, 1-1/2
15	FNTF1.5	Nut, 1-1/2 NF
16	FCSE.75X3.5	Capscrew, 3/4 x 3-1/2 grd. 8
17	FLW.75	Lockwasher, 3/4" (16 req'd/machine)
18	FNTH.75	Nut, 3/4" 2H (16 req'd/machine)
19	TB1.625X1.25X1	Bushing, 1-5/8 x 1-1/4 x 1 (included)
20	RWHP8.75X22	Wheel
21	RTIN11X22.5FS	Tire
	RPT57C	Mounted tire

**RPT40 Channel shim, 1/2 x 2 flat (Not shown)

* If there is no shank under the tower, use (2) RPT152

** In certain configurations, the outside RPT154LT or RT may sit half way on top of the shank aligning plate. If this occurs, use RPT40 to fill in the void between the beam and angle iron brkt.

Section E

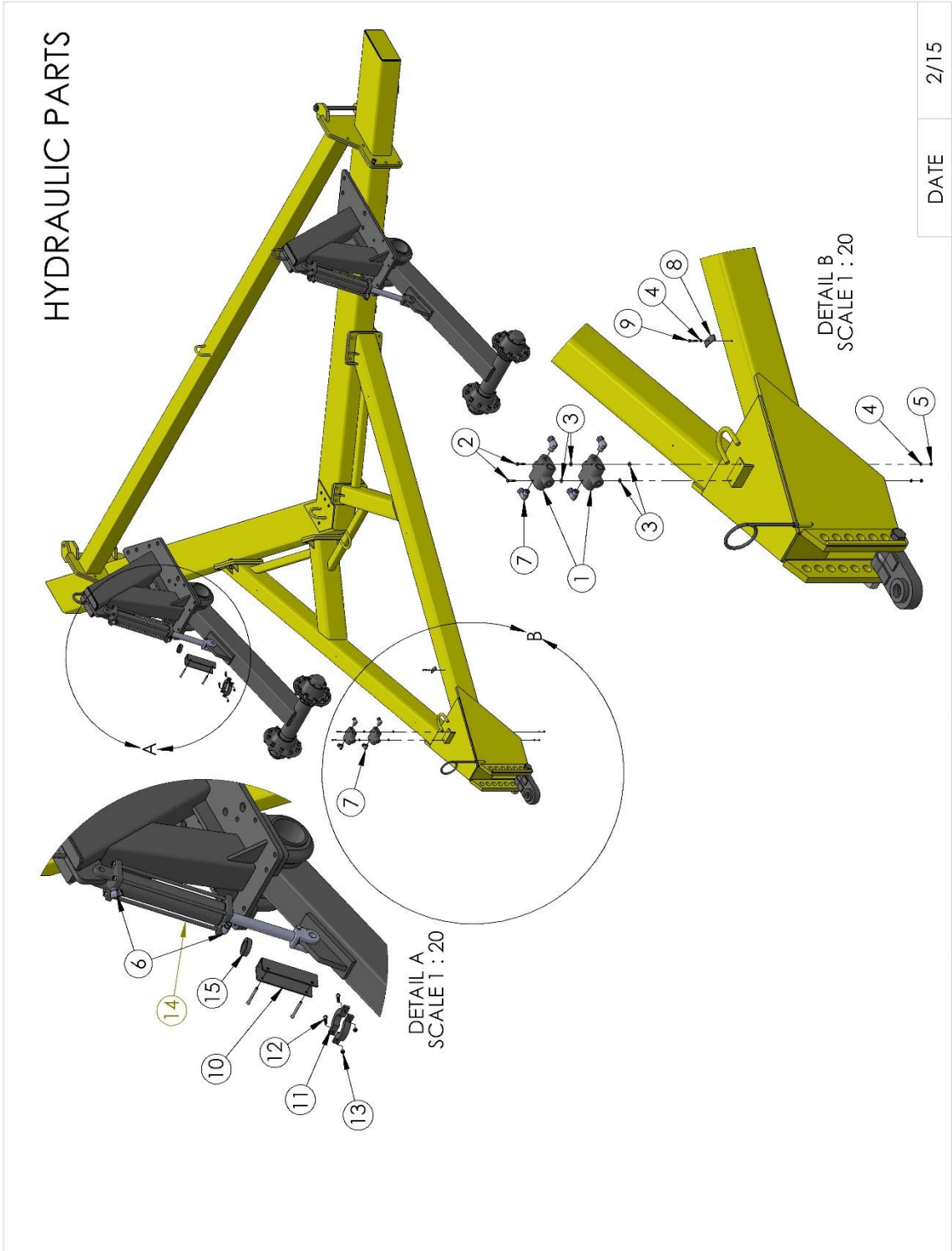

Section E

HYDRAULICS

See page E for drawing

- | | | |
|----|---------------|--|
| 1 | HVPROCOMB300 | Proportional combiner (2 req'd) |
| 2 | FCSE.4x4.5 | Cap screw, 1/4 x 4-1/2 (2 req'd) |
| 3 | FCWP.25 | Flat cut washer, 1/4" (4 req'd) |
| 4 | FLW.25 | Lock washer, 1/4" (8 req'd) |
| 5 | FNT.25 | Nut, 1/4" (2 req'd) |
| 6 | HE90VO.5X.5 | 90 degree "O" ring fitting (use with 4" cyl.) |
| | HE90VO.625X.5 | 90 degree "O" ring fitting (use with 5" cyl.) |
| 7 | HE90V.5X.5 | 90 degree fitting, (4 req'd) |
| 8 | HCPT7 | Hold down clip (6 req'd) |
| 9 | FCSV.25X1.5 | Cap screw, 1/4 x 1-1/2 (6 req'd) |
| 10 | BPT30 | Travel-stop pair with 3/8 x 3 loxall pins |
| 11 | RPT63 | 3/4" stop block half |
| | RPT64 | 1" stop block half |
| | RPT65 | 1-1/4" stop block half |
| | RPT66 | 1-1/2" stop block half |
| | RPT67 | 2" stop block half |
| | RPT81 | Stop block set for two cylinders consisting of 4 each of the stop block halves plus fasteners. |
| 12 | FCSE.375X1.5 | Cap screw, 3/8 x 1-1/2 |
| 13 | FNTL.375 | Lock nut, 3/8 |
| 14 | HYCY4X169716 | 4 x 16 tie rod cylinder |
| | HYCY5X16 | 5 x 16 tie rod cylinder |
| 15 | RPT21 | Cylinder Washer used only on 4 X 16" cylinder shaft between cylinder gland and stop blocks. |
- NOT SHOWN – 2 1/2" hydraulic hoses with pioneer tips and caps. 4 1/2" hoses. Lengths based on model number.

Section F

ITEM #	DESCRIPTION	4 X 16 CYLINDER	5 X 16 CYLINDER
1	PISTON ROD	HCYL4X169716	HCYL5X16
2	CLEVIS	HCYLSHAFT4X16TR	HCYLSHAFT5X16TR
3	BUTT	HCLV4X16	HCLV5X16
4	CLEVIS PIN/PINS	HBUJT9716	HBUJT5
5	NON ROTATING CLEVIS PIN	HCLVPIN1.25	HCLVPIN1.25
6	TIE ROD	HCLVPIN4NR	HCLVPIN5NR
7	GLAND	HCYTR16	HCYTR16
NP	SEAL KIT	HCYGLAND9716	HCYGLAND5TR
		HCYK4X16 (NEW)	HCYK5-3000
		HCYK4X169700 (OLD)	

NOTE: (New) seal kits for 4" cylinders are for subsoilers with serial numbers ending in 08 or higher.

DATE 4/15

1 2 3 4 5

Section F 1

[BACK TO INDEX](#)

Section G

HUBS

ITEM #	DESCRIPTION	PART #
1A	Hub housing, left	RHUBLT
1B	Hub housing, right	RHUBRT
*2A	Stud Bolt - Left Hand	RWSTUDSSLT
*2B	Stud Bolt - Right Hand	RWSTUDSSRT
3	Inner Bearing	RHUBKBLG
4	Outer Bearing	RHUBBEARSM
5A	Nut - Left Hand	RWHNTLT
5B	Nut - Right Hand	RWHNTRT
6	Hub Cap - Grease	RHUBCAP
7	Gasket	RHUBGAS
*8	Lockwasher - Cap	
*9	Cap Screw - Cap	
10	Lockwasher, 3/4"	FLW.75
*11	Backup nut	
12	Hub seal	RHUBSEALKB

*INCLUDED IN HUB10LT AND HUB10RT

DATE 3/15

1

2

3

4

5

Section H

SECTION H PARKING STAND

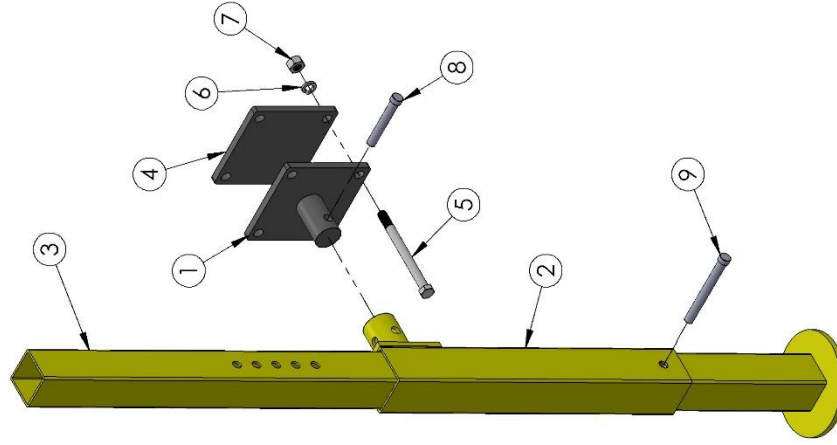

- | | | |
|---|-----------|----------------------------|
| 1 | RPT103 | PARKING STAND BRACKET |
| 2 | RPT104 | PARKING STAND SLEEVE |
| 3 | RPT105 | PARKING STAND LEG |
| 4 | RPT139 | PARKING STAND BACKUP PLATE |
| 5 | FCSE.75X9 | CAP SCREW 3/4 X 9 (4 REQ) |
| 6 | FLW.75 | LOCK WASHER 3/4" (4 REQ) |
| 7 | FNTH.75 | NUT 3/4" DH (4REQ) |
| 8 | FLXP.75X4 | LOXALL PIN 3/4 X 4 |
| 9 | FLXP.75X6 | LOXALL PIN 3/4 X 6 |

DATE 3/15

1

2

3

4

5