

### BUCKET SPECIFICATION

MACHINE MODEL	HS BUCKET 7-10 T
SERIES	HS 10 T SERIES
SPECIFICATION	HEAVY DUTY

### HS ATTACHMENTS-HS GROUP



MATERIAL COMPOSITION				
No	Description	Material	Thickness (mm)	Explanation
1		Ç 1040		
2	BOSS-X	S355 J2	11	
3	HINGE PLATE	S355 J2	18	ARCELOR
4	HINGE BOTTOM BOX	S355 J2	10	ARCELOR
5	HINGE CENTER PLATE	S355 J2	10	ARCELOR
6	HINGE BOTTOM	Ç 1040	10	ARCELOR
7	BOSS Y	S355 J2	50	
8	VERTICAL EDGE	HARDOX 450	20	ARCELOR
9	LOWER VERTICAL EDGE	S355 J2	30	SSAB
10	SIDE WALL L-R	S355 J2	12	SSAB
11	BODY BOTTOM	HARDOX 450	10	SSAB
12	EDGE	HARDOX 450	30	SSAB
13	SIDE PROTECTION	HARDOX 400	6	SSAB
14	WEAR STRIPS	S355 J2	10	ARCELOR
15	REINFORCEMENT	S355 J2	10	ARCELOR
16	REINFORCEMENT	S355 J2	10	ARCELOR
17	TOOTH			
18	ADAPTER			
19	LOCK			
		OPTIONAL TYPE		
	REINFORCEMENT	ST52-3	10	

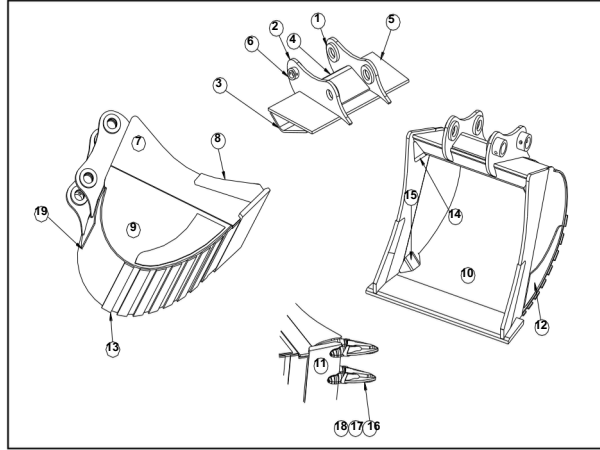

### Model Specification

	HS-7-10 T L:650 MM	HS 7-10 T L:800 MM
Edge Length (mm)	650	800
Capacity SAE (m <sup>3</sup> )	0,35	0,46
Weight (kg)	315	360
Teeth	3	4