

HSATTACHMENTS-HS GROUP

TECHNICAL SPECIFICATION

| | |
|---------------|-----------------------|
| MACHINE MODEL | HS BUCKET 50-65 TON |
| SERIES | HS 50-60 SERIES HEAVY |
| SPECIFICATION | DUTY |



| MATERIAL COMPOSITION | | | | |
|----------------------|--------------------|---------------|----------------|-------------|
| No | Description | Material | Thickness (mm) | Explanation |
| 1 | | S355 JR | | |
| 2 | HINGE PLATE | S355 JR | 50 | ARCELOR |
| 3 | HINGE SIDE RL-LH | S355 JR | 30 | ARCELOR |
| 4 | HINGE BOTTOM | S355 JR | 30 | ARCELOR |
| 5 | HINGE CENTER PLATE | HARDOX 450 | 30 | ARCELOR |
| 6 | VERTICAL EDGE | HARDOX 450 | 45 | SSAB |
| 7 | SIDE PLATE | HARDOX 450 | 15 | SSAB |
| 8 | L.SIDE PROTECTION | HARDOX 450 | 40 | SSAB |
| 9 | BODY | HARDOX 450 | 15 | SSAB |
| 10 | EDGE | HARDOX 450 | 70 | SSAB |
| 11 | WEAR STRIPS | HARDOX 450 | 15 | SSAB |
| 12 | WEAR STRIPS | HARDOX 450 | 20 | SSAB |
| 13 | WEAR STRIPS | HARDOX 450 | 20 | SSAB |
| 14 | WEAR STRIPS | HARDOX 450 | 10 | SSAB |
| 15 | ADAPTOR | OPTIONAL TYPE | | |
| 16 | TEETH | | | |
| | LOCK | | | |
| | | | | |
| | | | | |
| | | | | |
| | | | | |

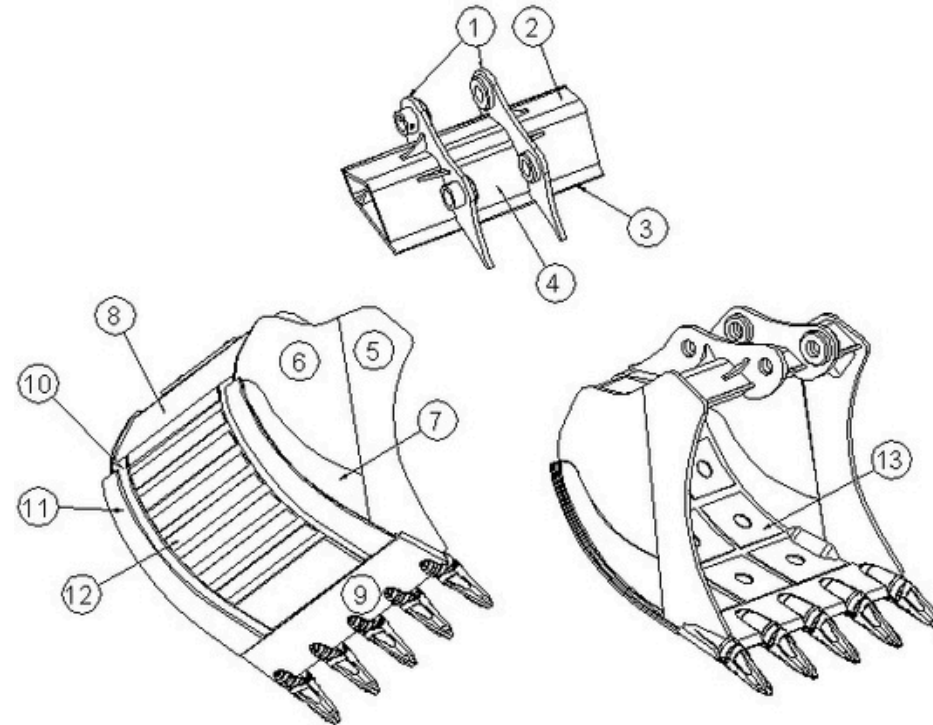

Model Specification

HS-50-60 L:1800

| | |
|--------------------------------|--------|
| Edge Length (mm) | 1800 |
| Capacity SAE (m ³) | 4 |
| Weight (kg) | 3230 |
| Nr Teeth | 6 |
| Cargo Ready | 2 Week |