

HS ATTACHMENTS-HS GROUP

BUCKET SPECIFICATION

MACHINE MODEL	HS BUCKET 40 -46 T
SERIES	HS 40 T Series HEAVY
SPECIFICATION	DUTY



MATERIAL COMPOSITION

No	Description	Material	Thickness (mm)	Explanation
1		S355JR2		
2	HINGE PLATE	S355JR2	40	ARCELOR
3	HINGE SIDE RL-LH	S355JR2	25	ARCELOR
4	HINGE BOTTOM	S355JR2	25	ARCELOR
5	HINGE CENTER PLATE	HARDOX 450	25	ARCELOR
6	VERTICAL EDGE	S355JR2	40	SSAB
7	SIDE PLATE	HARDOX 450	18	SSAB
8	L.SIDE PROTECTION	HARDOX 450	35	SSAB
9	BODY	HARDOX 450	12	SSAB
10	EDGE	HARDOX 450	60	SSAB
11	WEAR STRIPS	HARDOX 450	15	SSAB
12	WEAR STRIPS	HARDOX 450	15	SSAB
13	WEAR STRIPS	HARDOX 450	15	SSAB
14	WEAR STRIPS	HARDOX 450	10	SSAB
15	ADAPTOR	OPTIONAL TYPE		
16	TEETH			
	LOCK			

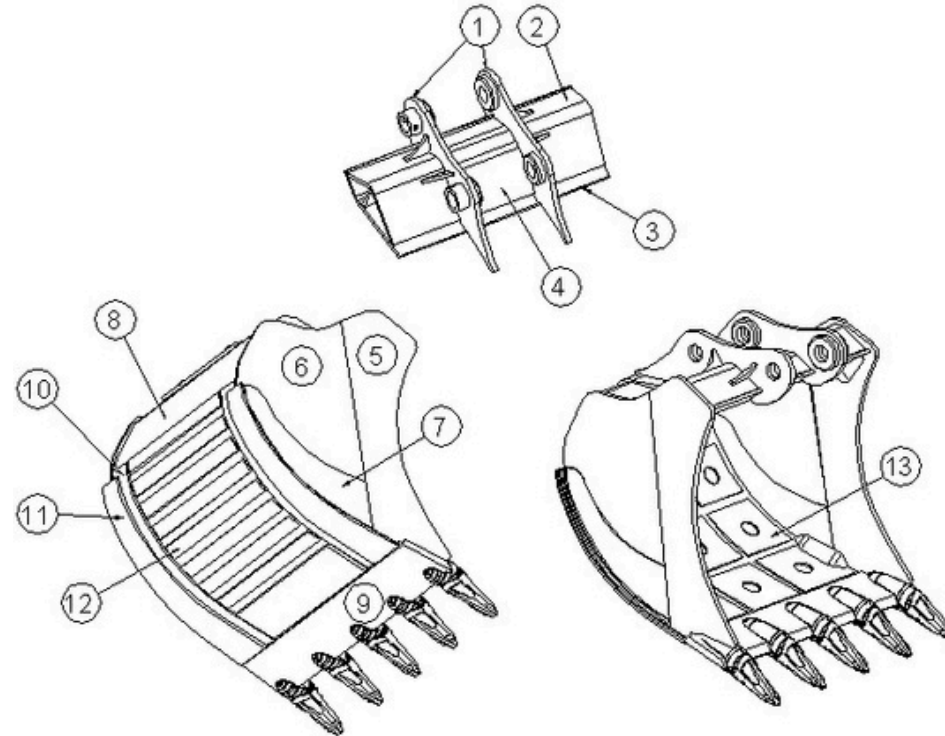

Model Specification

	HS 40-46 T L:1900	HS 40-46 T L:1700	HS 40-46 T L:1600	HS 40-46 T L:1500
Edge Length (mm)	1900	1700	1600	1500
Capacity SAE (m ³)	3,0	2,6	2,4	2,2
Weight (kg)	2050	1915	1840	1770
Teeth	5	5	5	5