

HSATTACHMENTS-HS GROUP



BUCKET SPECIFICATION

MACHINE MODEL	HS BUCKET 30-35 T
SERIES	HS 36 T SERIES
SPECIFICATION	HEAVY DUTY

MATERIAL COMPOSITION

No	Description	Material	Thickness (mm)	Explanation
1		S355JR2		
2	HINGE PLATE	S355JR2	30	
3	HINGE SIDE RL-LH	S355JR2	18	
4	HINGE BOTTOM	S355JR2	18	
5	HINGE CENTER PLATE	HARDOX 450	18	
6	VERTICAL EDGE	S355JR2	40	
7	SIDE PLATE	HARDOX 450	15	
8	L.SIDE PROTECTION	S355JR2	30	
9	BODY	HARDOX 450	15	
10	EDGE	HARDOX 450	50	
11	WEAR STRIPS	HARDOX 450	12	
12	WEAR STRIPS	HARDOX 450	12	
13	WEAR STRIPS	HARDOX 450	12	
14	WEAR STRIPS	HARDOX 450	10	
15	ADAPTOR	OPTIONAL TYPE		
16	TEETH			
	LOCK			

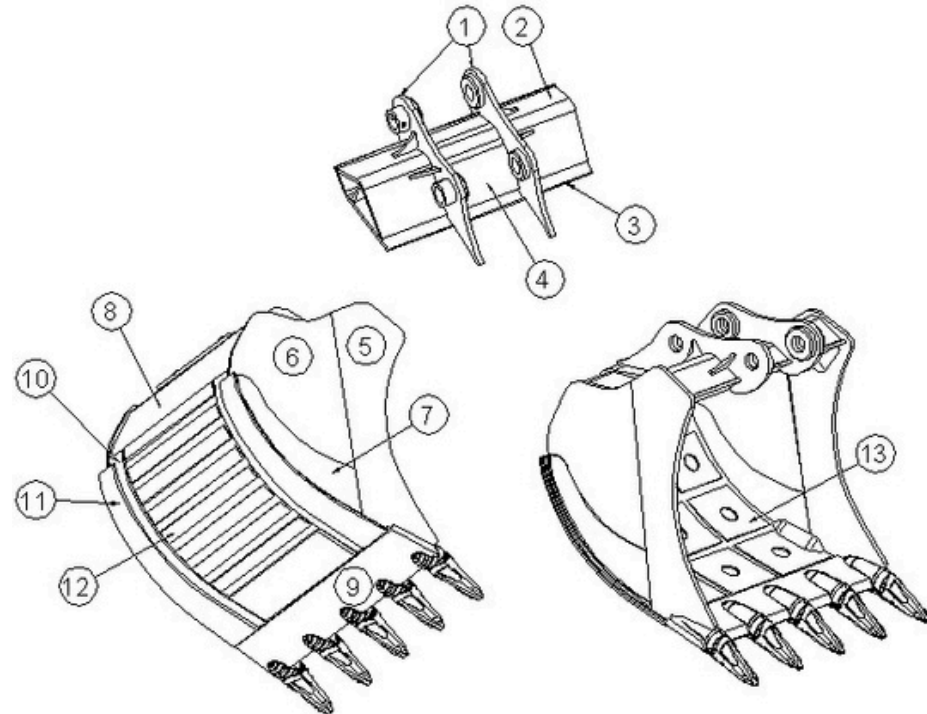

Model Specification

	HS30-35 T L:1600	HS30-35 T L:1550	HS 30-35 T L:1200	HS 30-35 T L:800	HS 30-35 T L:700
Edge Length (mm)	1600	1550	1200	800	700
Capacity SAE (m ³)	2,1	1,9	1,6	1,0	0,8
Weight (kg)	1550	1450	1280	1055	985
Nr Teeth	5	5	4	3	3