

# HSATTACHMENTS-HS GROUP

## BUCKET SPECIFICATION

MACHINE MODEL	HS BUCKET 24-27 T
SERIES	HS 27 T SERIES
SPECIFICATION	HEAVY DUTY



## MATERIAL COMPOSITION

No	Description	Material	Thickness (mm)	Explanation
1		S355 JR2		
2	HINGE PLATE	S355 JR2	25	ARCELOR
3	HINGE SIDE RL-LH	S355 JR2	18	ARCELOR
4	HINGE BOTTOM	S355 JR2	18	ARCELOR
5	HINGE CENTER PLATE	HARDOX 450	18	ARCELOR
6	VERTICAL EDGE	S355 JR2	35	SSAB
7	SIDE PLATE	HARDOX 450	12	ARCELOR
8	L.SIDE PROTECTION	S355 JR2	25	SSAB
9	BODY	S355 JR2	10	ARCELOR
10	EDGE	HARDOX 450	40	ARCELOR
11	WEAR STRIPS	HARDOX 450	10	SSAB
12	WEAR STRIPS	HARDOX 450	12	SSAB
13	WEAR STRIPS	HARDOX 450	12	SSAB
14	WEAR STRIPS	HARDOX 450	10	SSAB
15	ADAPTOR			
16	TEETH			
	LOCK			
		OPTIONAL TYPE		

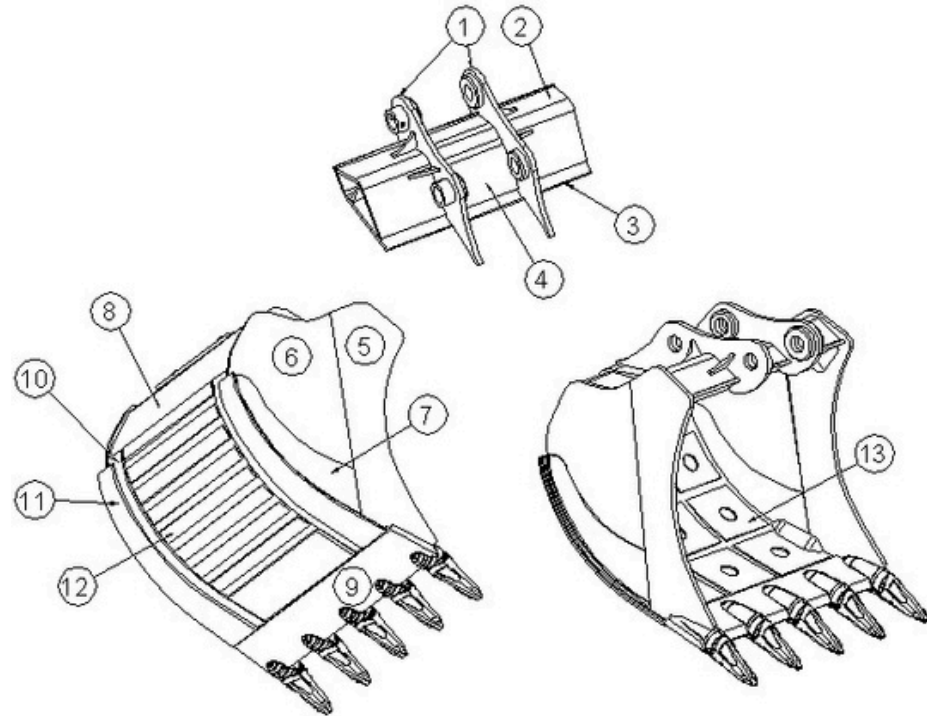

## Model Specification

	HS-24-27 T L:1500	HS-24-27 T L:1400	HS-24-27 T L:1200	HS-24-27 T L:1000	HS24-27 T L:800
Edge Length (mm)	1500	1400	1200	1000	800
Capacity SAE (m <sup>3</sup> )	1,55	1,45	1,24	1,0	0,82
Weight (kg)	1290	1205	1035	865	675
Nr Teeth	5	5	4	4	3