

HSATTACHMENTS-HS GROUP

| | |
|---------------|---------------------|
| MACHINE MODEL | HS 100-125 T SERIES |
| SERIES | HS 100-125 T BUCKET |
| SPECIFICATION | EXTRA HEAVY DUTY |

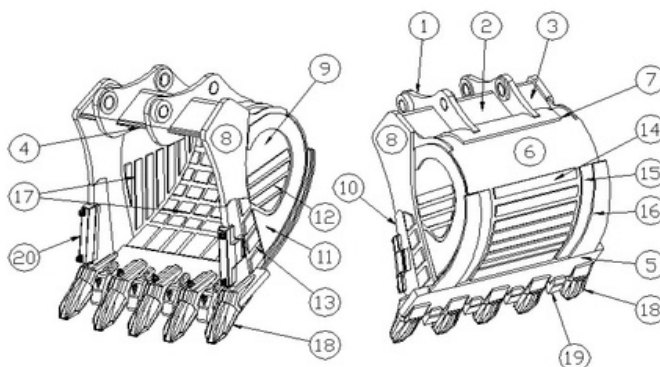

| MATERIAL COMPOSITION | | | | |
|----------------------|--------------------|------------|----------------|-------------|
| No | Description | Material | Thickness (mm) | Explanation |
| 1 | HINGE PLATE R-L | S355 JR2 | 70 | ARCELOR |
| 2 | CENTER BOX | S355 JR2 | 40 | ARCELOR |
| 3 | SIDE BOX R-L | S355 JR2 | 40 | ARCELOR |
| 4 | H.BOTTOM PLATE | S355 JR2 | 40 | ARCELOR |
| 5 | EDGE | S355 JR2 | 90 | ARCELOR |
| 6 | BODY | HARDOX 450 | 25 | ARCELOR |
| 7 | REINFORCEMENT | S355 JR2 | 40 | SSAB |
| 8 | U.VERTICAL EDGE | HARDOX 450 | 70 | ARCELOR |
| 9 | SIDE WALL | HARDOX 450 | 25 | SSAB |
| 10 | L.VERTICAL EDGE | HARDOX 450 | 80 | SSAB |
| 11 | SIDE PROTECTION | HARDOX 450 | 25 | SSAB |
| 12 | WEAR STRIPS | HARDOX 450 | 20 | SSAB |
| 13 | WEAR STRIPS | HARDOX 450 | 25 | SSAB |
| 14 | WEAR STRIPS | HARDOX 450 | 30 | SSAB |
| 15 | WEAR STRIPS | HARDOX 450 | 25 | SSAB |
| 16 | WEAR STRIPS | HARDOX 450 | 25 | SSAB |
| 17 | WEAR STRIPS | HARDOX 450 | 20 | SSAB |
| 18 | ADAPTOR+TEETH+LOCK | | | |
| 19 | SEGMENTS | | | |
| 20 | SEGMENTS | | | |
| MTG-ESCO | | | | |



Model Specification

HS 100-125 T L:2400

| | |
|--------------------------------|------|
| Edge Length (mm) | 2400 |
| Capacity SAE (m ³) | 6,75 |
| Weight (kg) | 8385 |
| Teeth | 6 |

PRICES (€)

