

HSATTACHMENTS-HS GROUP

MACHINE MODEL	HS BUCKET 12-14 T
SERIES	HS 12-14 T SERIES BUCKET
SPECIFICATION	HEAVY DUTY

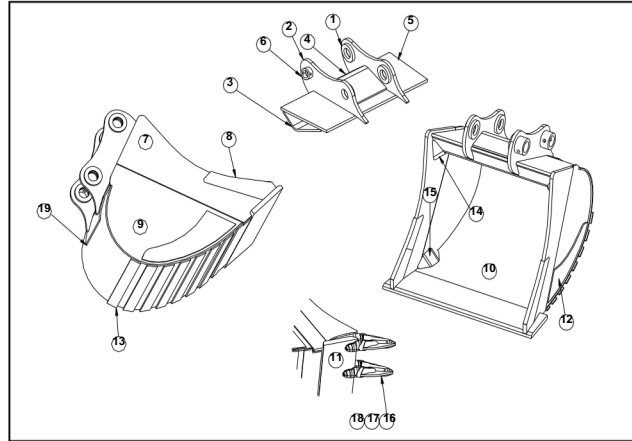

MATERIAL COMPOSITION				
No	Description	Material	Thickness (mm)	Explanation
2	BOSS X	S355J2	13	
3	HINGE PLATE	S355J2	20	ARCELOR
4	HINGE BOTTOM BOX	S355J2	18	ARCELOR
5	HINGE CENTER PLATE	S355J2	18	ARCELOR
6	HINGE BOTTOM	C 1040	10	ARCELOR
7	BOSS Y	S355J2	55	
8	VERTICAL EDGE	HARDOX 450	25	
9	LOWER VERTICAL EDGE	S355J2	35	ARCELOR
10	SIDE WALL L-R	S355J2	35	ARCELOR
11	BODY BOTTOM	HARDOX 450	10	ARCELOR
12	EDGE	HARDOX 450	35	ARCELOR
13	SIDE PROTECTION	HARDOX 450	8	SSAB
14	WEAR STRIPS	S355J2	10	SSAB
15	REINFORCEMENT	S355J2	10	ARCELOR
16	REINFORCEMENT		10	ARCELOR
17	TOOTH			
18	ADAPTER			
19	LOCK			
	REINFORCEMENT	S355J2	10	ARCELOR



Model Specification

	HS 12-14 T L:700	HS 12-14 T L:800	HS 12-14 T L:900
Edge Length (mm)	700	800	900
Capacity SAE (m ³)	0,50	0,65	0,75
Weight (kg)	520	550	570
Teeth	3	4	4