

HSATATCHMENTS-HS GROUP

| | |
|---------------|---------------------|
| MACHINE MODEL | HS 160-180 T SERIES |
| SERIES | HS 160-180 T BUCKET |
| SPECIFICATION | EXTRA HEAVY DUTY |

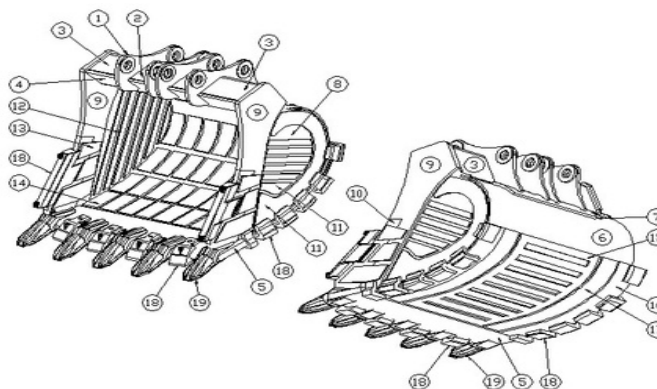

| MATERIAL COMPOSITION | | | | |
|----------------------|-----------------|------------|----------------|-------------|
| No | Description | Material | Thickness (mm) | Explanation |
| 1 | HINGE PLATE R-L | S355 JR2 | 45 | ARCELOR |
| 2 | CENTER BOX | S355 JR2 | 40 | ARCELOR |
| 3 | SIDE BOX R-L | S355 JR2 | 40 | ARCELOR |
| 4 | H.BOTTOM PLATE | S355 JR2 | 40 | ARCELOR |
| 5 | EDGE | S355 JR2 | 100 | ARCELOR |
| 6 | BODY | HARDOX 450 | 25 | ARCELOR |
| 7 | REINFORCEMENT | S355 JR2 | 40 | SSAB |
| 8 | SIDE WALL | HARDOX 450 | 25 | ARCELOR |
| 9 | U.VERTICAL EDGE | HARDOX 450 | 70 | SSAB |
| 10 | L.VERTICAL EDGE | HARDOX 450 | 80 | SSAB |
| 11 | SIDE PROTECTION | HARDOX 450 | 25 | SSAB |
| 12 | WEAR STRIPS | HARDOX 450 | 20 | SSAB |
| 13 | WEAR STRIPS | HARDOX 450 | 20 | SSAB |
| 14 | WEAR STRIPS | HARDOX 450 | 20 | SSAB |
| 15 | WEAR STRIPS | HARDOX 450 | 30 | SSAB |
| 16 | WEAR STRIPS | HARDOX 450 | 25 | SSAB |
| 17 | WEAR STRIPS | HARDOX 450 | 25 | SSAB |
| 18 | SEGMENTS | | | |
| 19 | | | | |
| ADAPTOR+TEETH+LOCK | | MTG-ESCO | | |



Model Specification

| | HS 160-180 L:2800 | HS 160-180 L:3100 |
|--------------------------------|-------------------|-------------------|
| Edge Length (mm) | 2800 | 3100 |
| Capacity SAE (m ³) | 11,25 | 12,35 |
| Weight (kg) | 12150 | 13450 |
| Teeth | 5 | 5 |