

RENOIR - 2 drawers - 600/800/1000

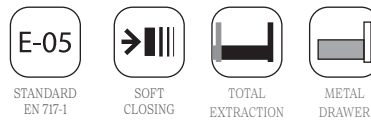

Exterior finishes



Interior finishes

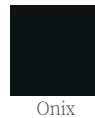

Technical information

Front Panels (e=19 mm):

- Mate: MDF board lacquered with matt water-based paint.
- Wood: MDF board PVC coated with 3D foil wrapping technology.

Side Panels (e=16mm):

- Mate: laminated particle board lacquered with matt water-based paint.
- Wood: laminated particle board. PVC edging "Testa" design with PUR glue.

Internal Structure Panels (e=16mm): Laminated particle board onix finish.

*All panels used in the manufacture of this unit are classed as E-1 grade with low level of formaldehyde content.

*Trim varies according to design: PVC, ABS (edged with PUR glue)

Fittings

Hangers: Heavy duty hanger with three independent adjustments accessible from the front. Load capacity 70Kg.

Drawer: Grass V8 metal drawer. Hidden high-end full-extension slides with cushioned closing and lateral and height adjustment. Max. load capacity 40 Kg.

Handles Handle, knob or shell in different finishes. Not included in the unit.

Handle models

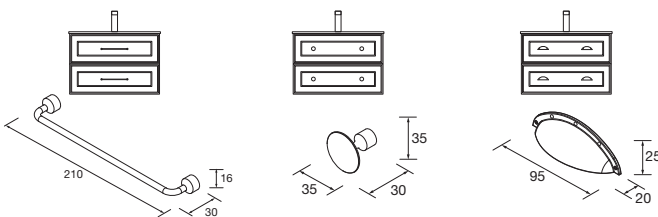

Packaging dimensions and weight

	600	800	1000
Length (mm)	660	860	1060
Depth (mm)	510		
Height (mm)	610		
Net weight (kg)	23,5	28,1	32,8
Gross weight (kg)	25,8	30,8	35,8

Dimensions

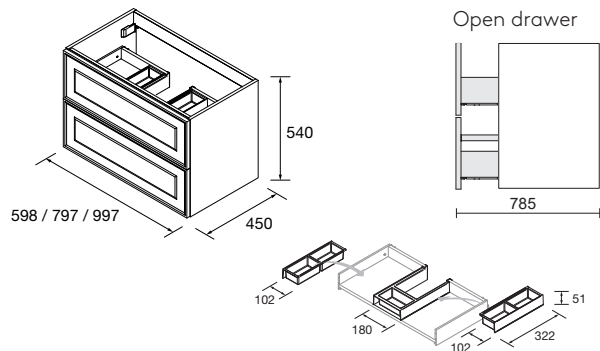

Back free space for water connections

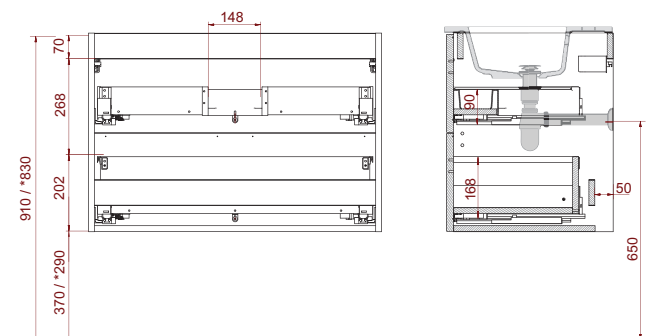

PILLAR RENOIR - 2 doors - height 1600

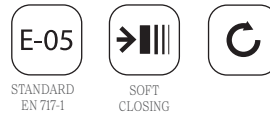

STANDARD
EN 717-1

SOFT
CLOSING

Finishes



White Cotton
NCS S 0500-N
RAL 9016



Black Velvet
NCS S 9000-N
RAL D2 000 15 00
Pantone Black 6C



Moon grey
NCS S 5502-Y
RAL D2 060 70 05
Pantone Cool Gray 5C



Macchiato
NCS S 2010-Y40R
RAL D2 060 70 10
Pantone 4255C



Green forest
NCS S 6005-G80Y
RAL D2 120 50 05
Pantone 4220C



Night Blue
NCS S 7020-R80B
RAL D2 280 20 10
Pantone 2580C



Blue Fog
NCS S 3005-B
RAL D2 240 70 05
Pantone 445C

Technical information

Front panels (thickness=19mm):

- Water-repellent MDF board with moulding design and 3D lacquered with super matt UV polyester paint.

Side panels (thickness =16mm):

- 3D lacquered particle board laminated with super matt UV polyester paint.

Internal Structure panels (thickness = 16mm): Laminated particle board onix.

Glass shelf (thickness=5mm): 4 height adjustable glass trays.

* All boards used in the manufacture of this furniture are classified as class E05 with low formaldehyde content.

*Edges according to design: PVC, ABS. (edged with PUR glue)

Interior finishes



Onix

Packaging dimensions and weight

Lenght (mm)	415
Depth (mm)	415
Height (mm)	1680
Net weight (kg)	30,9
Gross weight (kg)	33,4

Dimensions

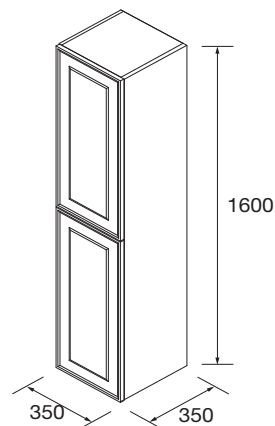

Fittings

Hangers: Heavy duty hanger with three independent adjustments accessible from the front. Load capacity 70Kg.

Hinge: Hettich hinge with damped locking.

Handle models

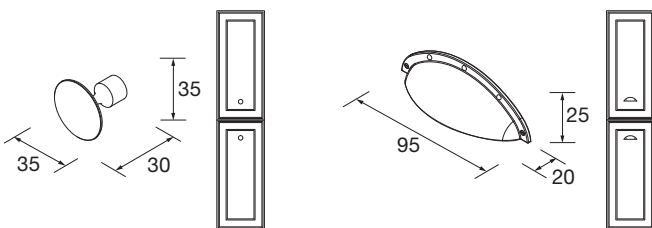

Renoir - Tiradores

STYLE

Tirador Zamak. Tornillería incluida.



Brass



Silver



Matt Gold



Matt Black
RAL 9004

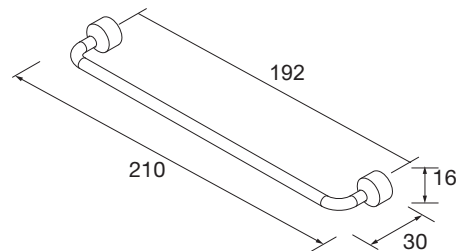

STYLE

Tirador Zamak. Tornillería incluida.



Brass



Silver



Matt Gold



Matt Black
RAL 9004

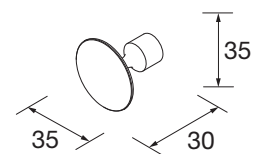

FOLK

Tirador Zamak. Tornillería incluida.



Chrome



Matt Black
RAL 9004



Gloss gold

