

MONTERREY - Wall-hung unit 1 drawer without pipe cut out 600 / 800 / 1000 / 1200

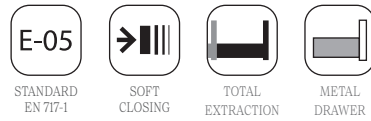

Exterior finishes

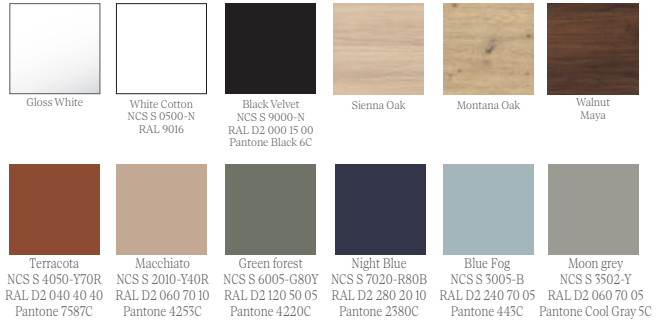

Interior finishes



Technical information

Front Panels (e=19 mm):

- Gloss: MDF board lacquered with High Gloss UV polyester paint.
- Mate: MDF board lacquered with matt water-based paint.
- Wood: MDF board PVC coated with 3D foil wrapping technology.

Side Panels (e=16mm):

- Gloss: laminated particle board lacquered with high gloss UV polyester paint.
- Mate: laminated particle board lacquered with matt water-based paint.
- Wood: laminated particle board. PVC edging "Testa" design with PUR glue.

Internal Structure Panels (e=16mm): Laminated particle board onix finish.

*All panels used in the manufacture of this unit are classed as E-1 grade with low level of formaldehyde content.

*Trim varies according to design: PVC, ABS (edged with PUR glue)

Fittings

Handle: Heavy duty hanger with three independent adjustments accessible from the front. Load capacity of 70Kg.

Drawers: Grass V8 metallic drawer onix finish. Highend hidden runners with total extraction, soft close and Side and height adjustment. Maximum load capacity: 30 kgs.

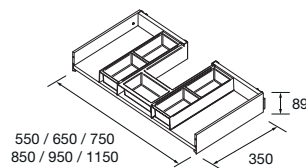

It is necessary to assemble a drawer to be able to combine with Constanza, Vilna, Alliance, Toscana. Drawer organizer included.

Packaging dimensions and weight

	600	800	1000	1200
Lenght (mm)	660	860	1060	1260
Depth (mm)	510			
Height (mm)	340			
Net weight (kg)	9,3	12,4	15,5	15,9
Gross weight (kg)	12,3	15,1	17,9	18,5

Dimensions

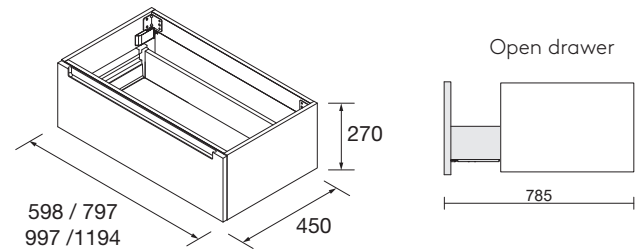

Back free space for water conections

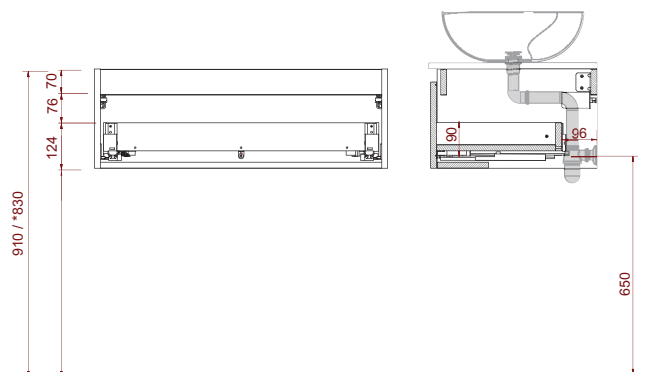

MONTERREY - Wall-hung unit 2 drawers - 600/700/800/900/1000/1200

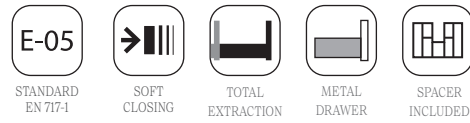

Exterior finishes

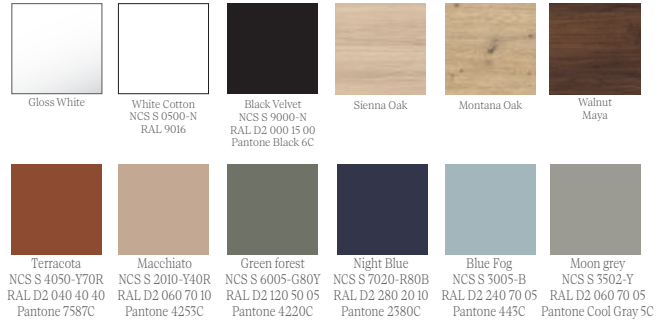

Interior finishes



Technical information

Front Panels (e=19 mm):

- Gloss: MDF board lacquered with High Gloss UV polyester paint.
- Mate: MDF board lacquered with matt water-based paint.
- Wood: MDF board PVC coated with 3D foil wrapping technology.

Side Panels (e=16mm):

- Gloss: laminated particle board lacquered with high gloss UV polyester paint.
- Mate: laminated particle board lacquered with matt water-based paint.
- Wood: laminated particle board. PVC edging "Testa" design with PUR glue.

Internal Structure Panels (e=16mm): Laminated particle board onix finish.

*All panels used in the manufacture of this unit are classed as E-1 grade with low level of formaldehyde content.

*Trim varies according to design: PVC, ABS (edged with PUR glue)

Fittings

Handle: Heavy duty hanger with three independent adjustments accessible from the front. Load capacity of 70Kg.

Drawers: Grass V8 metallic drawer onix finish. Highend hidden runners with total extraction, soft close and Side and height adjustment. Maximum load capacity: 30 kgs.

Packaging dimensions and weight

	600	700	800	900	1000	1200
Length (mm)	660	760	860	960	1060	1260
Depth (mm)	510					
Height (mm)	610					
Net weight (kg)	23	26,3	27,1	29,7	32,6	35,6
Gross weight (kg)	24,8	29	30,2	32,8	35,7	39

Dimensions

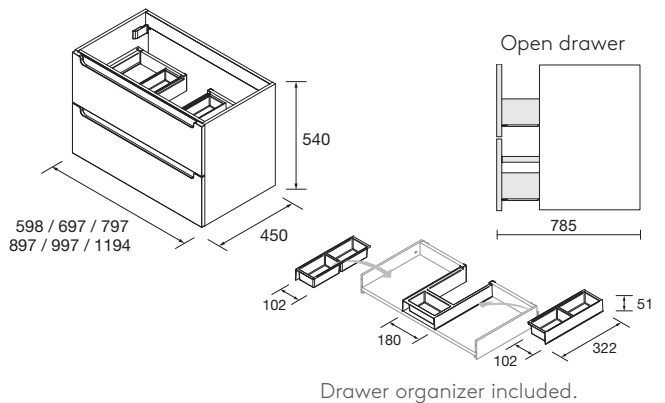

Back free space for water conections

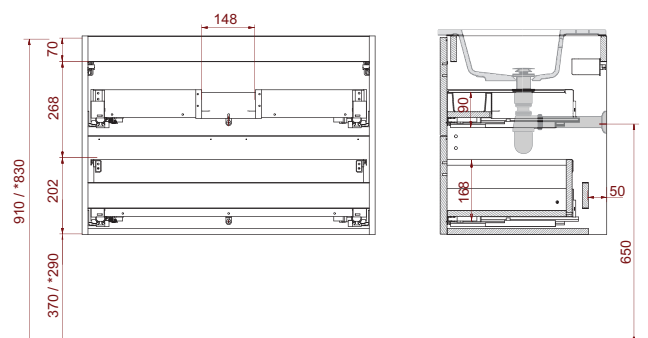

MONTERREY - Monterrey Module 300



E-05
STANDARD
EN 717-1



SOFT
CLOSING

Exterior finishes



Gloss White



White Cotton
NCS S 0500-N
RAL 9016



Black Velvet
NCS S 9000-N
RAL D2 000 15 00
Pantone Black 6C



Sienna Oak



Montana Oak



Walnut
Maya



Terracota
NCS S 4050-Y70R
RAL D2 040 40 40
Pantone 7587C



Macchiato
NCS S 2010-Y40R
RAL D2 060 70 10
Pantone 4253C



Green forest
NCS S 6005-G80Y
RAL D2 120 50 05
Pantone 4220C



Night Blue
NCS S 7020-R80B
RAL D2 280 20 10
Pantone 2380C



Blue Fog
NCS S 3005-B
RAL D2 240 70 05
Pantone 443C



Moon grey
NCS S 3502-Y
RAL D2 060 70 05
Pantone Cool Gray 5C

Technical information

Front Panels (e=19 mm):

- Gloss: MDF board lacquered with High Gloss UV polyester paint.
- Mate: MDF board lacquered with matt water-based paint.
- Wood: MDF board PVC coated with 3D foil wrapping technology.

Side Panels (e=16mm):

- Gloss: laminated particle board lacquered with high gloss UV polyester paint.
- Mate: laminated particle board lacquered with matt water-based paint.
- Wood: laminated particle board. PVC edging "Testa" design with PUR glue.

Internal Structure Panels (e=16mm): Laminated particle board onix finish.

*All panels used in the manufacture of this unit are classed as E-1 grade with low level of formaldehyde content.

*Trim varies according to design: PVC, ABS (edged with PUR glue)

Interior finishes



Onix

Packaging dimensions and weight

	300 x 540
Length (mm)	360
Depth (mm)	510
Height (mm)	620
Net weight (kg)	11,7
Gross weight (kg)	13,6

Dimensions

RIGHT

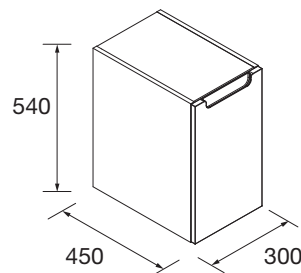

LEFT

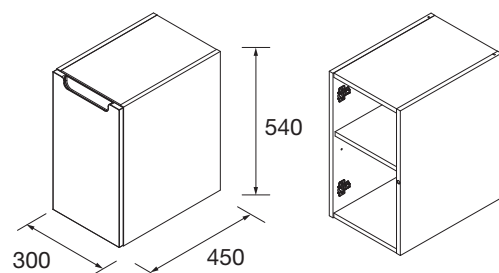

Fittings

Hangers: Heavy duty hanger with three independent adjustments accessible from the front. Load capacity 70Kg.

Hinges: Adjustable hinges with cushioned closing.