

## FUSSION LINE - Depth 40 - 500/700

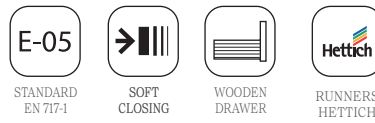

### Exterior finishes

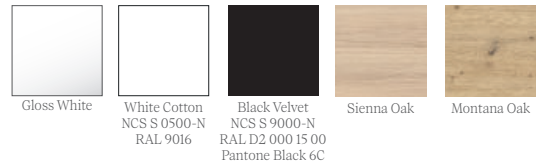

### Interior finishes



### Technical information

#### Manufacture of doors and sides (e=16mm):

- White: Laminated particleboard lacquered with ultra-gloss UV polyester paint.
- Mate: laminated particle board lacquered with matt water-based paint.
- Wood: laminated particle board. PVC song "Testa" with PUR glue

#### Internal structure construction (e=16mm): laminated particle board onix finish.

- \*All boards used in the manufacture of this furniture are classified as class E05 with low formaldehyde content.
- \*Edges according to design: PVC, ABS. (edged with PUR glue)

### Fitting

Cabinet hangers: Heavy duty hanger with three independent adjustments accessible from the front. Load capacity 70Kg.

Guide: Concealed Hettich extractor plus rails with soft closing and height adjustment. Max. load capacity 25 kg.

### Compatible Washbasins

- Wash basins available
- 500/700: Washbasins 40.

### Packaging dimensions and weight

	500	700
Length (mm)	560	760
Depth (mm)	445	
Height (mm)	610	
Net weight (kg)	16,5	20,2
Gross weight (kg)	18,5	22,6

### Dimensions

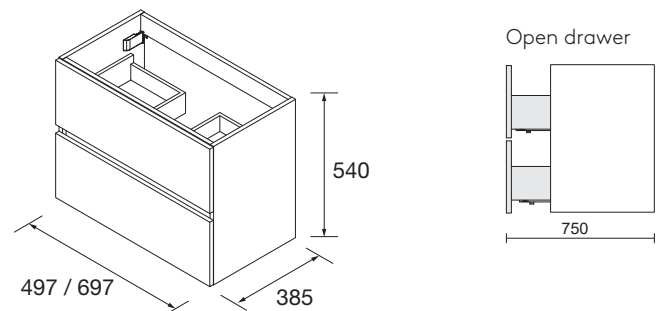

### Free space for water pipe

