

Virtual Coding and Robotics Camps

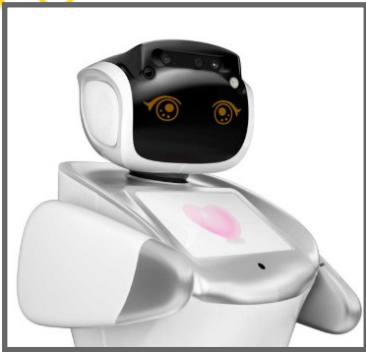

Kids: 8 –12

Teens: 13-19

Imagine, Think, Create

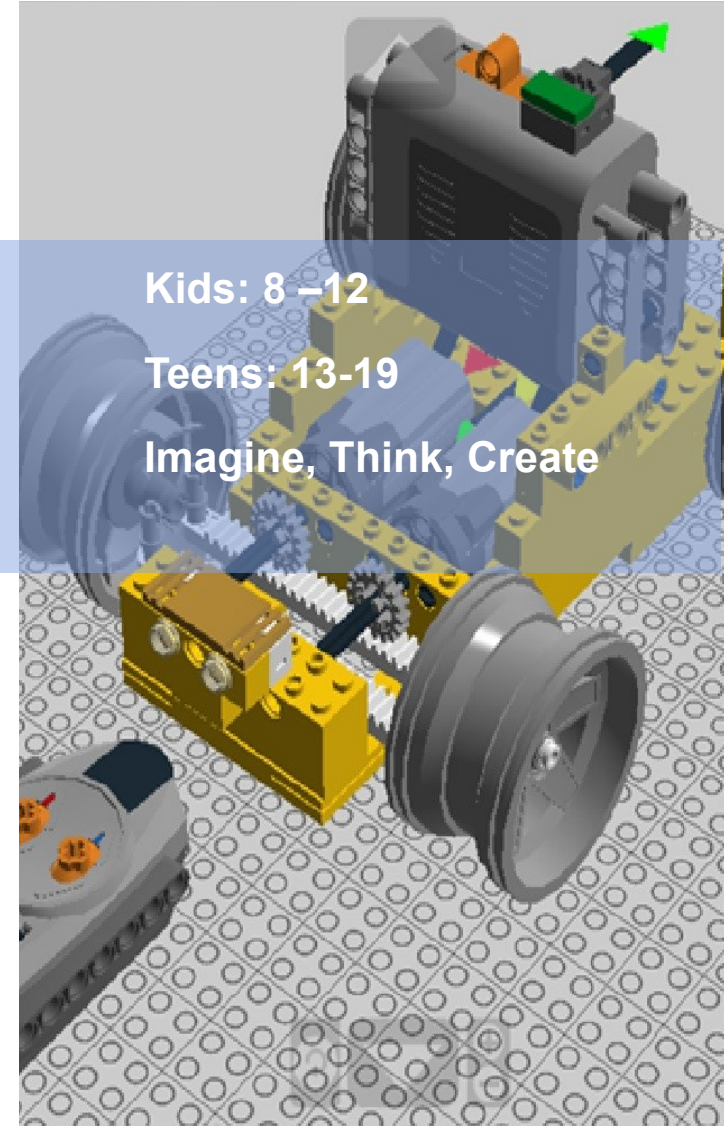

python



info@robo-geek.ca
www.robo-geek.ca

ROBO-GEEK
AI, Coding, Electronics & Robotics



Summer 2025 Camps

System Requirements

Kids Camps (8-12 years old): 5 different camps offered:

- > Java & Robotics
- > Python and Pygame
- > Arduino & Robotics
- > Python and Computer Vision & Robotics
- > Intro to C++

Teens Camps (13-19 years old): 6 different camps offered:

- > Python with Intro to AI Agent
- > Python and Pygame
- > Intro to C++
- > Arduino & Electronics
- > Artificial Intelligence with Python (3 levels)

Please check the **schedule** to see if you are interested in a particular camp.



■ Requirements for Kids and Teens Camps:

Laptops or PCs with the following **specifications**:

- > Windows 10/11 Operating System
- > **8 GB minimum**
- > HDD 40 GB free
- > Fast internet access
- > Headphones with microphones preferred
- > Student personal Gmail account
- > Free 30-60 minutes appointment with our technical staff to install all the required software ahead of camp. **Parent/Guardian required.**



www.robo-geek.ca

Summer 2026 Kids Schedule

Kids Camps (9 AM - 12 PM):

- J1 > July 6th— July 10th: **Arduino & Robotics & C**
- J2 > July 13th— July 17th: **Python and Pygame**
- J3 > July 20th— July 24th: **Intro to C++ & Robotics**
- J4 > July 27th— July 1st: **Python-Computer Vision & Robotics**
- A1 > Aug. 4th— Aug. 7th: **Python with Chess**
- A2** > Aug. 10th— Aug. 14th: **Python and Pygame**
- A3 > Aug. 17th— Aug. 21st: **Arduino & Robotics**
- A4 > Aug. 24th— Aug. 28th: **Intro to C++ & Robotics**

Summer 2026 Teens Schedule

Teens Camps (12:30 PM - 3:30 PM):

- J1 > July 7th— July 11th: **Arduino & Electronics & C**
- J2 > July 14th— July 18th: **Python and Pygame**
- J3 > July 21st— July 25th: **Intro to C++**
- J4 > July 28th— Aug. 1st: **Intro to AI with Python**
- A1 > Aug. 4th— Aug. 8th: **Python for AI Intermediate**
- A2** > Aug. 11th— Aug. 15th: **Python AI Intro to Agents**
- A3 > Aug. 18th— Aug. 22nd: **Advanced AI with Python**
- A4 > Aug. 25th — Aug. 29th: **Java with Android Studio**

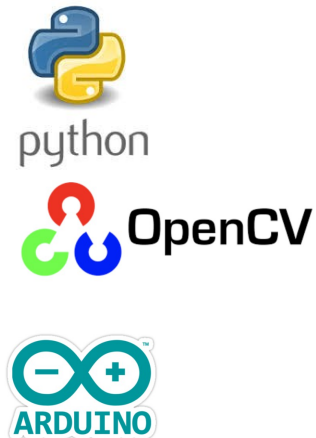

PYTHON and Pygame CAMPS

KIDS

Intro to Python – Practical

Students will be introduced to Python programming language. Python is a high-level programming language used in many universities and work institutions. Python is powerful and fast, yet friendly and easy to understand. Students will learn the fundamentals of coding using Python Turtle.



Intro to Game Program-

Students will learn step by step how to develop a working 2D game from designing characters, game rules and developing multiple game levels. In this course students will be introduced to Object Oriented Programming using Python Pygame. Games are highly portable capable to run on nearly every platform and operating system.

TEENS

STEM + Python Turtle

Students will learn about three STEM subjects: Solar System, Bridge Building and Gravity. For each subject, students will create programs in Python to simulate and demonstrate understanding. This course is based on the material developed in our STEM Club



Advanced Game Programming

Students will develop a multi-level game using Pygame using Object Oriented Programming integrating all the concepts learned.



Arduino CAMPS

KIDS

Introduction to Arduino

Students will learn coding in C with Arduino Uno Wi-Fi Board working with digital interfaces to control different arrays of LEDs virtually using Virtual Breadboard. Moreover, students will learn basic concepts of Electronics and Electricity through experimentation and hands-on activities including building of circuits on breadboards.



TEENS

Arduino Advanced

Working with simulators is a fundamental skill required in Engineering to develop troubleshooting and collaboration skills. Moreover simulators help students develop discipline to conduct tests prior to prototyping. We selected Virtual Breadboard for this purpose.

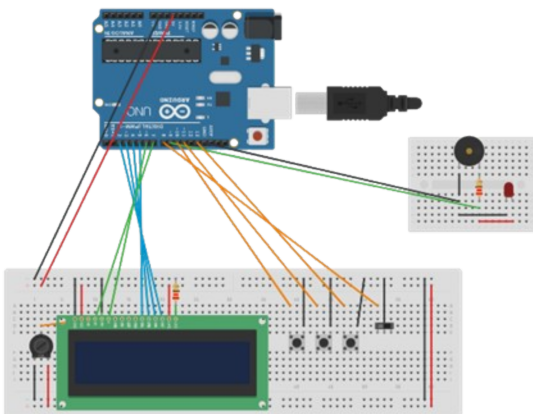

Java CAMPS

KIDS

Introduction to Java

Students will learn fundamentals of Java, type of variables, statements and operators, arrays, methods, and control structures. Moreover, we will expand into Object-oriented programming System (OOPs) concepts. We will cover each and every feature of OOPs in detail : Abstraction, Encapsulation, Inheritance and Polymorphisms. The section for Input /Output has included here too.



TEENS

Advanced Android Studio

Android Studio is a powerful tool based on Java. Students will learn how to work with API (Application Programming Interfaces), Project Structure, gradle, libraries, methods, onCreate() method, MainActivity and XML Layout. Students will learn how to create Apps for Android Tablets using Android Studio.



C++ CAMPS

KIDS

Introduction to C++

Students will learn fundamentals of C++, type of variables, statements and operators, arrays, methods, vectors, structs. Moreover, students will expand into Classes, Structs and Public and Private specifiers.



TEENS

Advanced C++

Students will learn fundamentals of C++, type of variables, statements and operators, arrays, methods, vectors, structs. And pointers. Moreover, we will expand into Object-oriented programming System (OOPs) concepts. We will cover each and every feature of OOPs in detail : Inheritance and Polymorphisms. Exception Handling in C++ responding to unexpected events scenarios.



Python Computer Vision CAMPS

KIDS

Introduction to Computer Vision

Students will learn about the fundamentals of Computer Vision using Python OpenCV. This course is designed to prepare students for more difficult and concepts in robotics and machine learning.

Students also learn how to apply advance algorithms using OpenCV for image processing including shape detection and object detection.



TEENS

Advanced Computer Vision

Students will learn the practical applications of computer vision in robotics and mobile applications such as QR code recognition, OCR recognition. Last part of the course focuses on integration with the application of AI to play



Artificial Intelligence (AI) - Python Camps

AI

Intro to Artificial Intelligence (AI)

This course provides a foundational understanding of Artificial Intelligence (AI), focusing on Python programming and machine learning concepts. Students will gain hands-on experience using Colab Notebooks and explore real-world applications of AI.

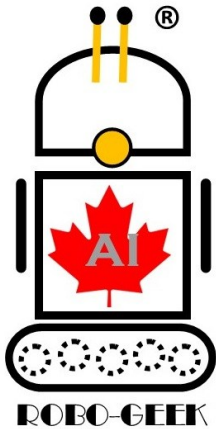

AI with Python

Intermediate Artificial Intelligence (AI)

This course aims to comprehensively understand deep learning, emphasizing practical application using TensorFlow and Colab Notebooks. Students will build a solid foundation in Python programming and delve into advanced TensorFlow



Artificial Intelligence (AI) - Python Camps

AI-Build your AI Agent

Build your own AI Agent

Build your own AI Inbox Agent! Teens learn Gmail API, AI sorting logic, VIP filters, summarization, and data extraction through hands on projects.

By the end, each student creates a smart email assistant that sorts, summarizes, and drafts replies

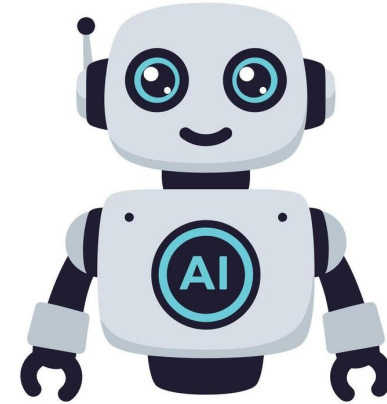

AI with Python

Intro to Artificial Intelligence (AI)

This course provides a foundational understanding of Artificial Intelligence (AI), focusing on Python programming and machine learning concepts. Students will gain hands-on experience using Colab Notebooks and explore real-

