

Product Catalog

Industrial applications · GxP-regulated applications

INDOOR ENVIRONMENTAL MONITORING SYSTEMS

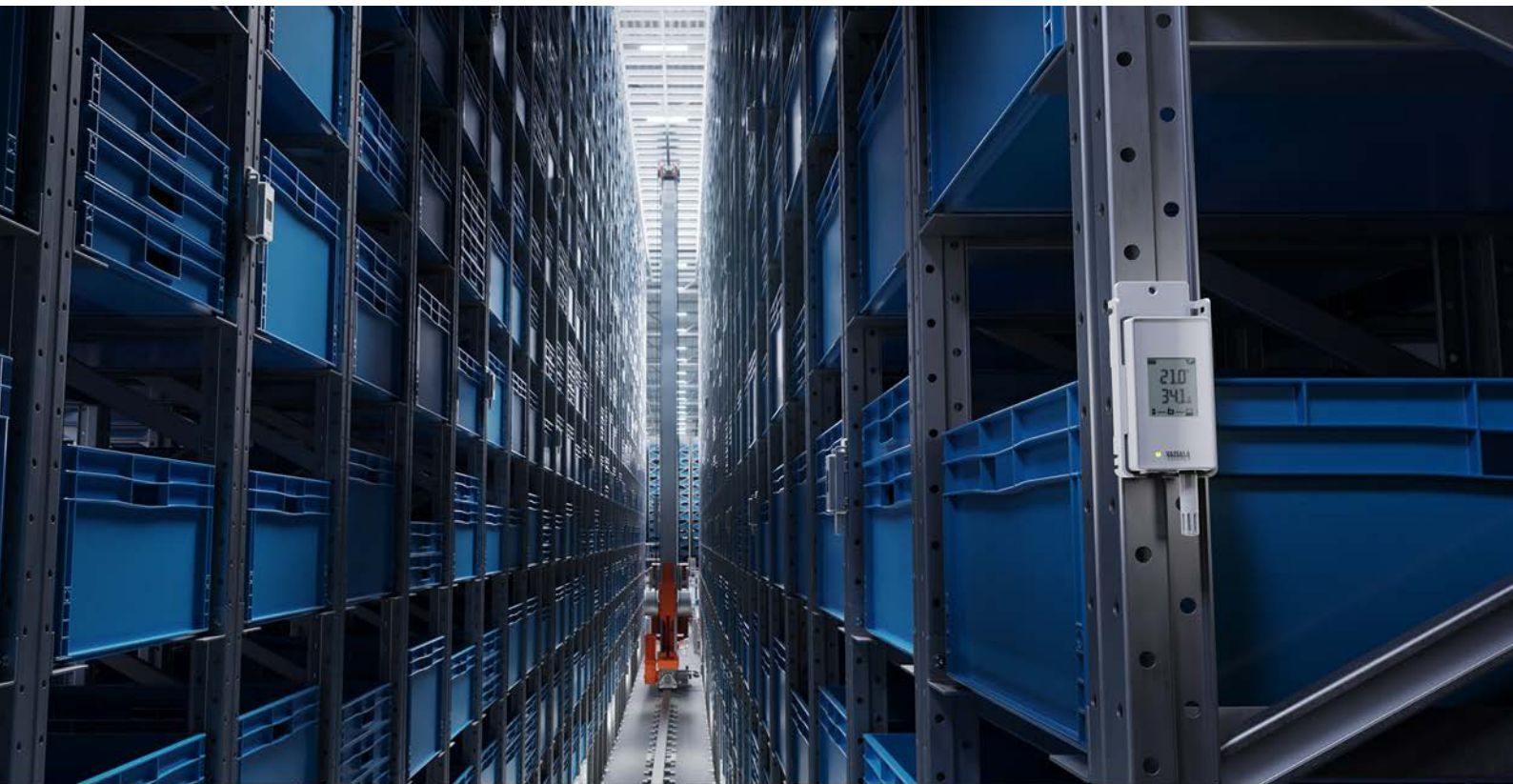

VAISALA

About Vaisala

Vaisala Industrial Measurements

Vaisala's Industrial Measurements business area provides customers with visibility into their own processes. Our products provide them with accurate and reliable measurement data which enables them to make decisions for optimized industrial processes.

With the reliable data from our instruments, customers can increase process efficiency, product quality, productivity, and yield but decrease energy consumption, waste, and emissions. Our monitoring systems also help our customers operating in the regulated environments to fulfill their regulatory compliance.

Industrial Measurements' customers operate in different types of environments from semiconductor factories and high-rise buildings to power plants and health technology laboratories where reliable measuring and monitoring of the ambient conditions are a prerequisite for successful operations.

Life science and pharmaceutical industry

For over 50 of the world's top life science companies, Vaisala provides measurement devices and monitoring systems for continuous records, reports and alarms. These solutions are used to monitor temperature and humidity conditions in research and development, production, and storage environments. With our solutions and services, life science companies ensure the quality and safety of their products, and maintain compliance with global regulations.

This product catalog provides an overview of our products to help you select what best suits your needs. For more information, visit us at vaisala.com or contact us at vaisala.com/requestinfo. Product user documentation is available at docs.vaisala.com.



Table of contents

Monitoring systems

Jade Smart Cloud Monitoring System for industrial applications.....	6
Jade Smart Cloud	8
viewLinc Continuous Monitoring System for GxP-regulated environments.....	12
viewLinc Cloud Monitoring System.....	13
viewLinc Enterprise Server software.....	15

Data loggers and data logger connectivity

AP10 VaiNet Wireless Access Point	17
RFL100 Wireless Data Logger for Continuous Monitoring Systems.....	20
VDL200 Data Logger for Continuous Monitoring Systems.....	25
DL2000 Temperature and RH Data Logger	29
DL4000 Universal Data Logger	31
DL1000-1400 Temperature Data Logger	33
DL1016-1416 Multi-application Temperature Data Logger	37
DL1700 Thermocouple Data Logger	39
Mid-range Data Loggers for temperature, humidity, and contact channel measurement.....	41
vNet Power over Ethernet Data Logger Interface.....	44

Transmitters

Indigo510 Transmitter for Vaisala Indigo-compatible probes.....	46
Indigo520 Transmitter for Vaisala Indigo-compatible probes.....	49
HMT120 and HMT130 Humidity and Temperature Transmitters.....	53
TMT120 and TMT130 Temperature Transmitters	56

Interchangeable measurement probes

TMP115 Wide-Range Temperature Probe	59
HMP63 Humidity and Temperature Probe	61
HMP115 Humidity and Temperature Probe	64
HMP110 Humidity and Temperature Probe	66
GMP251 Carbon Dioxide Probe	69
GMP252 Carbon Dioxide Probe for ppm-level measurements.....	72
ANP115 Analog Input Probe.....	75
HPP270 Series Probes for hydrogen peroxide, humidity, and temperature measurement.....	77

Handhelds for spot-checking and calibration

Indigo80 Handheld Indicator for portable diagnostics.....	81
HMP80 Series Handheld Humidity and Temperature Probes for spot-checking applications.....	84
DMP80 Series Handheld Dew Point and Temperature Probes for spot-checking applications.....	87
HM40 Series Handheld Humidity and Temperature Meter.....	90

Differential pressure

CAB100 CMS Industrial Cabinet for data collection in cleanrooms and industrial settings.....	94
PDT101 Differential Pressure Transmitter	97
PDT102 Differential Pressure Transmitter.....	99

Humidity calibrator

HMK15 Humidity Calibrator	101
--	-----

Vaisala service offering

Life Cycle Services for Vaisala viewLinc Continuous Monitoring System.....	103
On-site calibration for Continuous Monitoring Systems.....	109
GxP Documentation Package for Vaisala viewLinc Continuous Monitoring System.....	111
Vaisala contact information.....	113



Choose Jade when you need:

- Access to your measurement data anywhere & anytime
- Fast and easy installation
- Easy access via web browser on any device
- Mobile optimized remote monitoring and alarming
- Secure data storage on the cloud
- Adaptable and scalable configurations for any application
- Simple to use system for any industrial monitoring need

Revolutionize your monitoring

Experience unparalleled precision and reliability with Vaisala Jade Smart Cloud, the cutting-edge monitoring solution designed to optimize your operations in industrial and commercial applications.

Unlock numerous benefits with our advanced cloud based monitoring software. Setting up the system is effortless—no software installation required. Simply log in and start using it right away.

Harness the power of real-time data and history data analytics to ensure that your environmental or process conditions are always performing at their best.

Enjoy seamless access across all devices, including mobile phones and tablets. Wherever you are, you can securely access your data whenever you need it.

Stay ahead with proactive alerts, easy reporting, user-friendly local & remote use, and seamless integration with compatible Vaisala measurement devices.



Access your system easily, both locally and remotely

Monitoring

Continuously track and visualize measurement values in real-time, providing immediate insights into your processes.

History data

Track long-term data trends through interactive, zoomable graphs, which help in visualizing trends and understanding process and environmental conditions over time.

Alerting

Vaisala Jade Smart Cloud provides a flexible and reliable alerting feature to ensure timely notifications when conditions deviate from set thresholds.

Reporting

The easy-to-use reporting feature provides users with detailed and accessible data insights. Reports are simple to generate quickly, without extensive training or technical knowledge.



Compatible devices



INDIGO500

series transmitters for high-class industrial measurements

- Color touch screen display
- 2-4 analog outputs
- 2 × relays
- 24 V DC or AC power
- Data logging
- Ethernet port, Modbus TCP/IP
- Interchangeable smart probes
- Barometric pressure option



RFL100 & AP10

VaiNet data loggers and access points for wireless data logging

- Temperature, humidity and CO₂
- > 100m signal range
- Up to 32 loggers per AP10
- Ethernet port (PoE) in AP10
- Onboard memory (30d)
- Gap-free data
- Interchangeable probes



VDL200

data loggers for multi-parameter data logging via Ethernet

- Temperature, humidity and CO₂
- Multiparameter display
- Ethernet connectivity
- PoE support
- Backup battery
- Onboard memory (30d)
- Gap-free data
- Interchangeable probes



MHT410

transmitters for online key gas monitoring of power transformers

- Supported parameters: Moisture, Hydrogen and Temperature
- Connects to Jade Smart Cloud via INDIGO500 transmitter

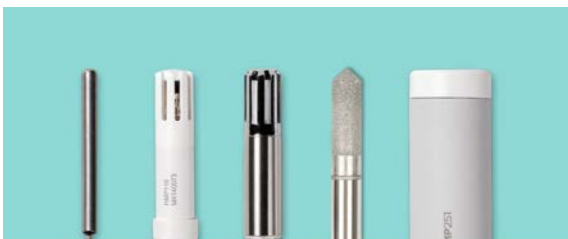

Measure precisely and reliably with Vaisala probes

Our cutting-edge measurement probes are designed to meet the diverse needs of industries worldwide. With a focus on precision, reliability, and innovation, our probes provide accurate data for critical applications across various sectors.

Vaisala probes seamlessly connect to our advanced data loggers and transmitters. The probes can measure a wide range of parameters, including humidity, temperature, dew point, carbon dioxide, moisture in oil, and vaporized hydrogen peroxide.

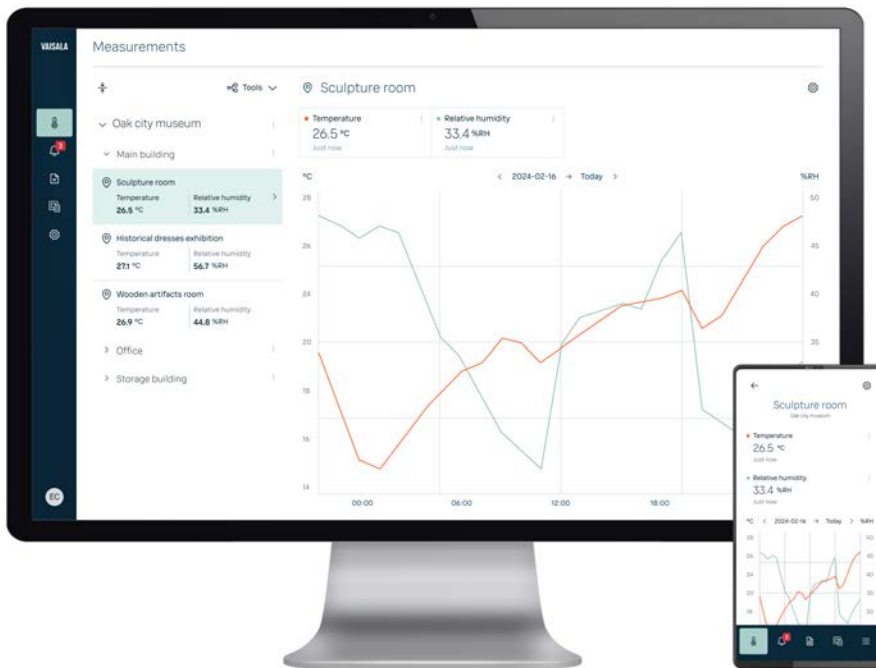

Features

- Online service for monitoring a variety of measurement parameters, including humidity and temperature
- Secure cloud storage of data
- Management of sites using an intuitive system of measurement groups and locations
- Connect using a web browser on your computer, tablet, or mobile phone
- Manage devices, users and roles based on your needs
- No device pairing needed, as devices are associated with a specific cloud account when they are purchased

Vaisala Jade Smart Cloud is a convenient cloud-based data service for monitoring and analyzing measurement data. The application can be accessed through a web browser on your computer, tablet, or mobile phone, making it ideal for professionals who want secure access to quality measurement data anywhere and at any time.

Monitoring

Continuous monitoring provides immediate insights into your processes. Access live measurement values to be always informed about the state of your operations.

Detect and respond to changes or anomalies as they happen. Customize the monitoring interface to display the most relevant data for your specific needs.

Alerts

The flexible and reliable alerting feature ensures timely notifications when conditions deviate from set limits. Send alerts through multiple channels, including email and SMS.

Immediately detect critical environmental changes, enabling timely and appropriate actions.

History and trends

Track long-term data trends through interactive graphs, which help in visualizing trends and understanding process and environmental conditions over time.

Select specific time frames to view trends from the past day, week, month, or even longer periods.

Analyze large amounts of historical data with the customizable data-averaging function. Raw measurement data is always available for analyzing details at the level of a single measurement sample.

Reporting

The easy-to-use reporting feature provides detailed and accessible data insights. Easily generate reports in PDF format that include data visualizations in graphs and tables.

Export data in CSV format, allowing easy integration with other tools and software. Enable benchmarking between different measurement locations to identify variations and trends across multiple sites.

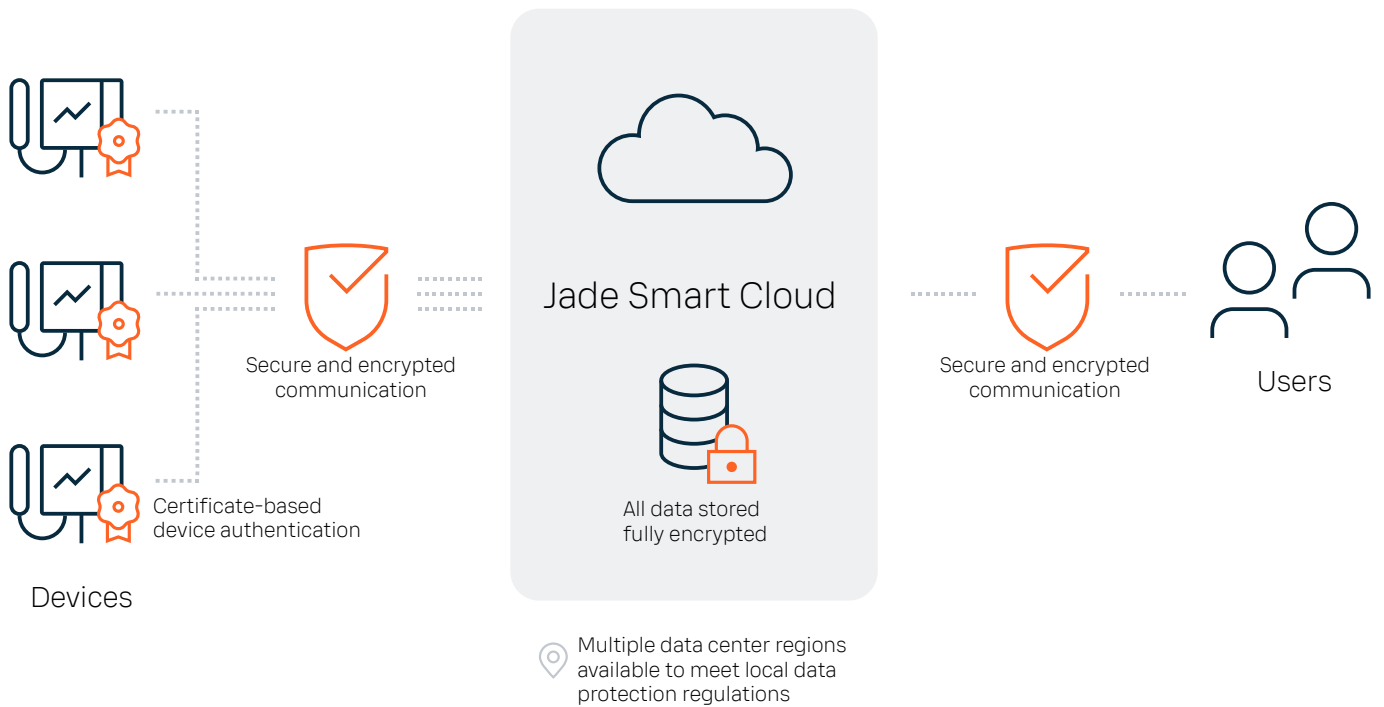

Easy setup

The system is very easy to get started with. No additional software is needed. No device pairing is needed, as the devices are associated with a Jade Smart Cloud account when they are purchased. New devices become automatically available in the system. With the intuitive user interface, users can easily link measurement parameters to measurement locations. Measurement locations can then be organized into multilevel measurement groups for easy navigation.

Easy access

The Jade Smart Cloud web application is built on modern web technologies and supported by all major desktop and mobile browsers. There is no app to install and maintain. The user interface is always available online at: jade.vaisala.com

Secure connectivity and data storage

The Jade Smart Cloud monitoring solution employs advanced security measures to protect your information and data communication from devices to the cloud and further to users.

Multiple regions are available to meet local data protection regulations.

Device management

The number of devices can be chosen based on customer requirements. Monitor device connection status and alerts, and change device settings based on your requirements. All data is securely stored in the cloud.

Subscription service

Basic tier provides access to all the monitoring and analyzing features. Add-on features are available for specific requirements. More add-on features will be made available later.

Feature	Basic tier	Add-on
Live measurement data	✓	
Viewing historical measurement data using graph or table view	✓	
Exporting measurement data reports in PDF and CSV format	✓	
Organizing measurement locations under groups	✓	
Device and probe details, including calibration date	✓	
Alerts for measurement locations and devices	✓	
User configurable alert rules	✓	
Alert notifications by email	✓	
Inviting new users to access your account	✓	
User rights and site access control using Administrator, Operator, and Viewer roles	✓	
Alert notifications by SMS		✓

Technical data

Web application

Web address	https://jade.vaisala.com
Web interface protocol	TLS 1.3
Supported Internet browsers	All modern and up-to-date browsers, including, but not limited to: Google Chrome™ Apple Safari® Microsoft Edge® Mozilla Firefox®
User interface languages	English, Finnish, French, German, Japanese, Portuguese, Spanish, Swedish

Supported devices

Device model	Connection requirements
RFL100 Data Logger	Connects wirelessly through AP10 Access Point. The access point must be associated with the same customer account. See RFL100 Data Logger Datasheet (B211595EN) .
AP10 Access Point	Ethernet network with Internet connection. See AP10 Access Point Datasheet (B211597EN) .
VDL200 Data Logger	Ethernet network with Internet connection. See VDL200 Data Logger Datasheet (B212433EN) .
Indigo510 Transmitter	Ethernet network with Internet connection. See Indigo510 Datasheet (B212305EN) .
Indigo520 Transmitter	Ethernet network with Internet connection. See Indigo520 Datasheet (B211735EN) .

Data center regions

Multiple regions available to meet local data protection regulations.

Data center	Region
Jade Smart Cloud data center - EU	European Union
Jade Smart Cloud data center - NA	North America

viewLinc Continuous Monitoring System for GxP-regulated environments



Choose viewLinc when you need:

- Unlimited parameters and gap-free data for compliance
- Easy-to-use IQOQ protocols, GxP documentation
- A full suite of service options, including: installation, validation, and global calibration
- Validated data that can be shared with external control and automation systems

Designed for life science and GxP-regulated environments, Vaisala's viewLinc Continuous Monitoring System (CMS) ensures gap-free data, reliable alarming, and records that comply global regulatory requirements such as 21 CFR Part 11 and Annex 11.

Versatile and reliable

Ideal for cleanrooms, laboratories, GDP warehouses, and hospitals, the viewLinc Enterprise Server-based system provides a web-based interface for remote monitoring, secure audit trail, customizable reporting, and reliable alarming through email, text, phone, or signal tower and annunciator.

Flexible connectivity

The system scales easily, includes nine language versions, and offers flexible connectivity options, including: Ethernet, PoE, Wi-Fi, and Vaisala's powerful wireless technology, VaiNet.



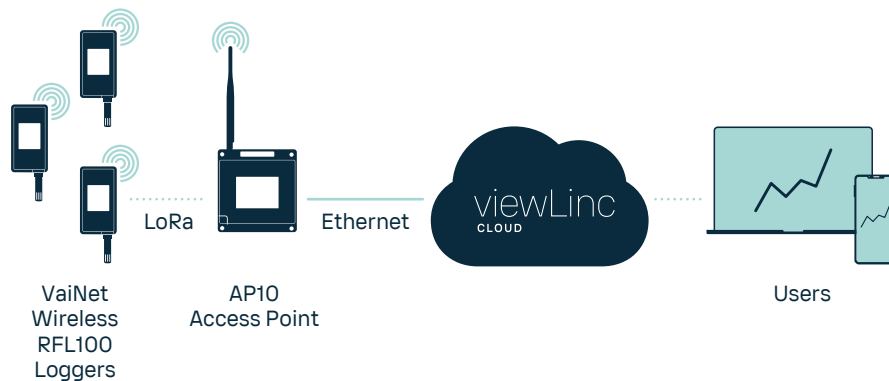

Features

- Cloud service for monitoring measurement parameters such as temperature, humidity, and CO₂
- Secure cloud storage of data
- Support for ten languages
- Configurable alarm notifications by email
- Continual, automated validation of the system
- Connect using a web browser
- Add devices and users based on your needs
- Automatic device pairing

Vaisala viewLinc Cloud is a powerful cloud-based environmental monitoring system designed specifically for GxP applications, providing automated alarming and reporting capabilities to ensure the safety and efficacy of your products. The system is accessed through a web browser from anywhere with an Internet connection, making it ideal for professionals who want access to quality measurement data anywhere and at any time. viewLinc Cloud is instantly scalable to suit your monitoring requirements, allowing your system to range from one to thousands of measurements and multiple users with different roles and responsibilities.

viewLinc Cloud helps ensure that enterprises in GxP-regulated industries achieve and demonstrate compliance with stringent quality guidelines and processes. From its data integrity, access controls, and encryption to its continuous validation system, viewLinc Cloud provides a faster and simpler path to a compliant monitoring system.

Easy setup

As a cloud service, there is no software to install or servers to manage. No device pairing is needed. New devices connect to the cloud service automatically and become available in the system within minutes. With the intuitive user interface, administrators can easily configure alarms to notify staff before conditions go out of specification. And users can see current conditions and report on historical conditions instantly.

Cloud-based service

viewLinc Cloud is offered as Software-as-a-Service (SaaS). Vaisala takes care of most of the typical IT functions for you, such as server management, security and backup. With reduced load on your IT department and a convenient subscription model that eliminates significant upfront costs, viewLinc Cloud is very easy to adopt.

Security

In viewLinc Cloud, data is always encrypted, both in transit and at rest. Access to the application is controlled via multi-factor authentication and within the application access is further restricted by role-based user rights, allowing for a high degree of control over who can see and do what.

Data integrity

The software maintains your data in a complete, consistent, and accurate state, adhering to the principles of ALCOA++. Modification or deletion of data is prevented, and modification of configurations is restricted and recorded in the secure audit trail.

Validation

viewLinc Cloud simplifies the process of validating your monitoring system. An initial qualification report is provided with your subscription. Additionally, the Continuous Validation System performs regular, automated tests on system status and functionality, and provides documented evidence of compliance.

Scalable

You can quickly expand or reduce your viewLinc Cloud installation. Our system accommodates installations ranging from a few measurements to several thousand, and can be localized at one site or spread across the globe.

Technical data

The license tier defines which set of features is available in the user interface. The Standard tier provides all of the essential management and user features. Additional tiers with more complex functionality will be made available later.

License tiers

Feature	Standard tier
Configurable interface to match your facility or organizational structure	✓
Live measurement data	✓
Trend graph	✓
Alarms for measurement locations and devices	✓
Alarm notifications by email	✓
User configurable alarm rules	✓
Device and probe details, including calibration date and battery status	✓
Reports available in XLSX, CSV, and PDF	✓
Rights-based access defines what users can do and see within the system	✓

Web application

Property	Description/value
Web address	https://viewlinc.com
Web interface protocol	TLS 1.3
Supported Internet browsers	All modern and up-to-date browsers, including, but not limited to: Google Chrome™ Microsoft Edge®
User interface languages	English, Finnish, French, German, Portuguese, Spanish, Swedish, Italian, Chinese, Japanese

Supported devices

Device type	Connection requirements
RFL100 Wireless Data Logger	Connects wirelessly through AP10 access point. The access point must be associated with the same customer account.
AP10 VaiNet Wireless Access Point	Ethernet network with Internet connection

Network requirements

Device type	Network requirements
AP10 VaiNet Wireless Access Point	Requires outbound TCP port 443 and UDP port 123

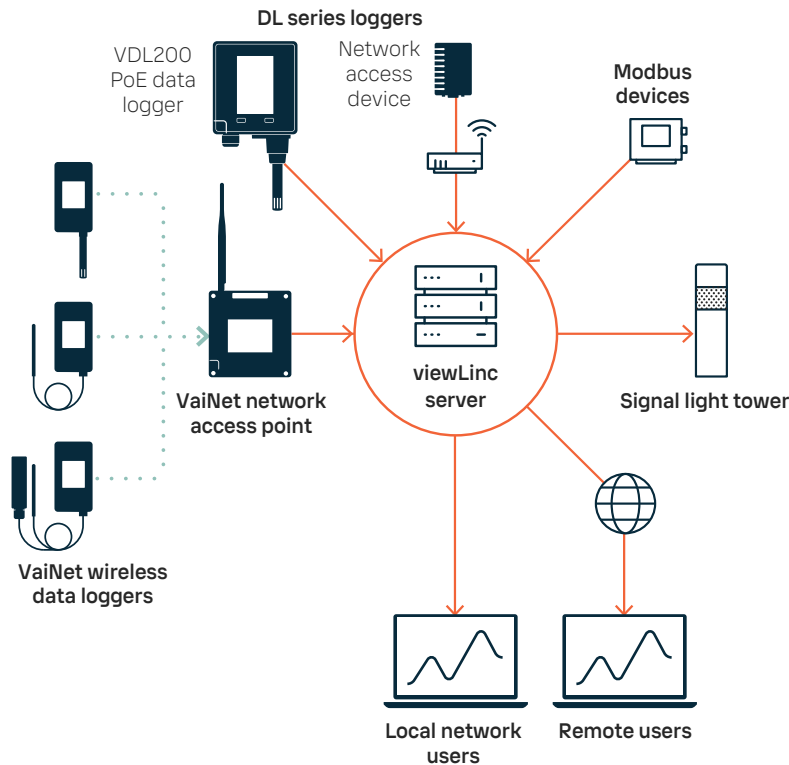

Features

- Software for continuous monitoring of temperature, humidity, and other parameters
- Eleven language versions for enterprise-wide, multi-site use
- Preconfigured and custom reports
- Windows Active Directory for easy user management
- Configurable alarm notifications: email, SMS, voice calls, signal towers, browser alerts
- Scheduled threshold alarming and alarm notification delivery times to accommodate maintenance periods or work shifts
- Interactive tours for novice users
- Licensed features: Voice/SMS web service, 3rd-party Modbus devices, Vaisala OPC UA Server, REST API

Vaisala viewLinc Enterprise Server software lets you network Vaisala data loggers or Modbus devices using a combination of wired and wireless connections. It supports installations from one or two measurement points to large systems with thousands of locations. Through user engagement and agile development, Vaisala delivers an always-improving product with new features and better performance. From its data integrity, access controls, and encryption to its validation protocols, viewLinc provides a faster and simpler implementation of your compliant monitoring system, particularly for enterprises in GxP-regulated industries seeking stringent quality guidelines and processes.

Upgrading

- Only viewLinc 4.3.6 and higher can upgrade to 5.2 directly. Lower versions must first upgrade to 4.3.6.
- During upgrade, confirm list of previously provided hostnames/aliases so users can connect to viewLinc.
- Starting in 5.2, viewLinc uses Transport Layer Security (TLS) 1.3, so all Vaisala VaiNet AP10 Access Points in the installation need firmware version 4.5 or newer. AP10s version F and older must be replaced.

System requirements

- Use a dedicated server (virtual server is recommended) continuously available 24/7 to run viewLinc software. Do not use a desktop O/S or a laptop to run critical monitoring applications.
- At least one Vaisala data logger or transmitter
- Vaisala cables to connect data loggers and set up wireless transmitters

Continuous reliability

- Accessible via browser on any network computer or mobile device

- Runs as a Microsoft® Windows® service
- Supports UTF-8 compliant multi-byte character sets

Licensing

- License key required for each installation and determines the number of devices
- Additional licenses enable voice or SMS web notifications, Vaisala OPC UA Server integration, the viewLinc REST API, or third-party Modbus devices

Technical data

Requirements based on system size

System size in measurement points	1 ... 20	21 ... 400	400+
Dedicated or shared server	Either	Either	Dedicated
CPU	1.6 GHz dual core	1.6 GHz dual core	3.2 GHz quad core
RAM	8 GB	12 GB	16 GB
Disk space increase/year	1.5 GB/year for 20 data points	15 GB/year for 200 data points	75 GB/year for 1000 data points
Continuous free disk space for reports ¹⁾	2 GB	4 GB	10 GB

¹⁾ 1 month duration with 1 minute scan/sample

Server requirements

Availability	Dedicated server (a virtual server is recommended) available 24 hours a day, 7 days a week
Server management	Connected to an uninterruptible power supply (UPS) A tested backup solution with support for open file backup Synchronizes time with a Network Time Protocol (NTP) server
Operating system	Windows Server® 2025 Windows Server® 2022 Windows Server® 2019 Windows Server® 2016 Windows® 11 Pro (for non-critical applications only) Windows® 10 Enterprise (64-bit, for non-critical applications only)
Application disk space	350 MB
Database disk space ¹⁾	200 KB/data point ^{2)/day}
Network traffic ³⁾	Approx. 100 KB/minute/device
Web interface protocol ⁴⁾	TLS 1.3
Security certificate for web interface	Authorized TLS certificate and key ⁵⁾
Email encoding	RFC 2047
Secure email protocol	TLS 1.3
Active Directory server	2048-bit RSA certificate

¹⁾ Not applicable to Device Host installation.

²⁾ Data points are device channels monitoring and recording data.

³⁾ Depends on number of devices, system configuration and type of communication devices used.

⁴⁾ viewLinc 5.2 includes software developed by the OpenSSL Project for use in the OpenSSL Toolkit.

<http://www.openssl.org/>

⁵⁾ viewLinc-signed certificate and key can be generated during installation.

Client requirements

Internet browser	Google Chrome™ Microsoft® Edge™
Computer clients	Any network computer with a supported Internet browser, a minimum 2.4 GHz CPU, and 4 GB of RAM.
Display and tablet clients	Touchscreen or mouse-operated panel with a supported Internet browser. Must be connected to the same network as viewLinc Enterprise Server.

Wireless device connectivity

RFL100 series ¹⁾	Connects using Vaisala VaiNet protocol. Requires installation of an AP10 access point.
-----------------------------	--

¹⁾ VaiNet devices not available in all regions.

Wired device connectivity

VDL200	Connects to a viewLinc Device host via Ethernet after its network settings have been configured through a USB-A – USB-C cable.
--------	--

DL series using vNet device	vNet Power-over-Ethernet devices are 802.3af compliant and work with both end-point and mid-span systems. viewLinc Aware automatically detects and configures vNet devices. ¹⁾ Requires vNet device drivers (provided).
-----------------------------	--

DL series using single or multi-port Ethernet device	Ethernet connectivity devices must be configured with static or reserved IP addresses. If the devices are being installed on different subnets, they need to be configured before being installed. Ethernet device drivers must be installed on each server used to connect Vaisala devices.
--	--

DL series using USB cable	Connect devices directly to viewLinc Device Hosts using a USB-to-logger cable. Requires USB ports.
---------------------------	--

Modbus devices (RTU or TCP)	<ul style="list-style-type: none"> Connect Modbus RTU devices directly to viewLinc Device Hosts using a USB-to-serial cable Connect Modbus RTU devices to viewLinc over the Ethernet network using a Serial to Ethernet adapter (like a Digi PortServer) Connect Modbus TCP devices to viewLinc over the Ethernet network RTU devices require serial COM ports. TCP devices require a static IP address.
-----------------------------	---

Signal tower (light and/or buzzer)	Connect devices according to manufacturer directions. Preconfigured device settings are selectable in viewLinc. Note that you must assign a static or reserved IP address for signal towers.
------------------------------------	--

¹⁾ vNet devices maintain a low power rating by operating at a network speed of 10 Mbps. To ensure your network devices can operate at different speeds, set the network speed for the connected vNet port (see vNet User Guide).

Network ports

Default	Type	Used by
80	TCP	Signal towers
389	TCP	Active Directory (less secure)
443	TCP	viewLinc web interface
502	TCP	Modbus TCP-enabled devices
636	TCP	Active Directory (secure connection)
771	TCP	vNet and multi-port Ethernet devices
950	TCP	Moxa serial-to-Wi-Fi devices
8883	TCP	VDL200
9065	UDP	viewLinc Aware service for vNet discovery
12500	TCP	Twilio web services
12600	TCP/UDP	AP10 and viewLinc device host
55000	TCP	Vaisala OPC UA Server



Features

- Connects up to 32 RFL100 data loggers to a Vaisala monitoring system
- Powered by Power over Ethernet (PoE) or DC adapter
- Minimal infrastructure and no signal amplifiers needed
- Chirp spread spectrum wireless modulation is resistant to multi-path fading
- Secure data transmission
- Secure firewall and tamper-proof data backup

VaiNet Access Point AP10 is a wireless networking hardware device for Vaisala's proprietary wireless technology: VaiNet. AP10 transfers measurement data from wireless VaiNet data loggers to the monitoring system, and enables the remote configuration and management of VaiNet data loggers by the system's administrator. A wired Ethernet network connection is required.

AP10 with a cloud-based monitoring system

AP10 supports Vaisala viewLinc Cloud and Vaisala Jade Smart Cloud, both cloud-based data services for managing measurement data. When used with a cloud-based data service, the installation is very simple. No device pairing is needed, as the devices are associated with the cloud account when they are purchased. New devices become automatically available in the system. Both supported cloud-based monitoring systems can utilize 8 access points and up to 256 wireless data loggers on a single site.

AP10 with an on-premise monitoring system

On-premise monitoring systems utilize Vaisala viewLinc Enterprise Server software. Instead of device pairing being preconfigured at the factory, the administrator of viewLinc ES has control over pairing. Whenever a new data

logger is added to the system, AP10 automatically identifies it and forwards its information to viewLinc ES. The administrator of viewLinc ES makes the decision to accept the new device.

With viewLinc ES, the access points and data loggers can be deployed as a large VaiNet system by using the VaiNet segmentation feature. Systems with up to 32 access points and up to 1024 data loggers can be deployed on a single site, as long as the large system installation guidelines are followed.

AP10 synchronizes with default NTP servers over the Internet. When used with the viewLinc ES, AP10 can be configured to use your local NTP server, which allows operation without an Internet connection.

Data integrity

Data is encrypted during VaiNet transfers to protect against eavesdropping, data tampering, and transfer errors. Both the access point and the monitoring system

verify that the data has been received correctly. Once the data is verified, it is stored to the monitoring system's secure database and protected from tampering and loss.

Redundancy

Redundancy of the wireless connection is achieved through use of multiple VaiNet access points and free connection capacity in the system. If a VaiNet data logger has a connection problem, it will automatically connect to another available access point in the system. At least 2 access points with free capacity are needed for failover to function.

Time synchronization

AP10 requires accurate time to operate its VaiNet wireless connection, and to maintain correct time on the connected data loggers. To achieve the accurate time, AP10 synchronizes with Network Time Protocol (NTP) servers.

Technical data

Wireless

Networking standards	Vaisala VaiNet
Wireless connection capacity	Up to 32 supported devices
Modulation	Chirp spread spectrum modulation
Output power	13 dBm (20 mW)
Antenna	Non-removable external antenna
Typical range (indoors)	At least 100 m (approx. 330 ft)
Maximum number of access points in an area	
Standard system	8
Large system ¹⁾	32
Frequency bands	
API0C model	500 MHz
API0E model	868 MHz
API0A model	915 MHz
API0J model	920 MHz
API0K model	921 MHz
API0T model	922 MHz

¹⁾ Requires viewLinc Enterprise Server. Subject to additional installation requirements. See *Guidelines for Large VaiNet Systems (M212596EN)*.

General

Compatible monitoring systems ¹⁾	viewLinc Enterprise Server 5.0 and newer viewLinc Cloud Jade Smart Cloud
Supported wireless devices	RFL100 data logger
User interfaces	Touchscreen interface Web browser interface ²⁾
User interface languages ³⁾	English, German, French, Portuguese, Spanish, Swedish, Chinese, Japanese
Internal clock	Synchronizes with Network Time Protocol (NTP) server on UDP port 123. NTP server connection required for operation.

¹⁾ See *product datasheets at docs.vaisala.com* for more information.

²⁾ Not available on cloud-connected variant.

³⁾ Only English language is available on the cloud-connected variant.

Inputs and outputs

Supply voltage using dedicated power supply connector	10–30 V DC
PoE power class	Class 0
Power consumption	Max. 13 W
Ethernet interface	
Supported standards	10BASE-T, 100BASE-TX
IPv4 address assignment	DHCP (automatic), static ¹⁾
Connectors	
Power supply connector	2.0 mm center pin locking type DC power jack
Service port	Micro-USB (2.0)
Expansion port	USB type A (2.0)
Ethernet	8P8C (RJ-45)

¹⁾ Static IP address assignment is not available on the cloud-connected variant.

Operating environment

Operating environment	Indoor use
IP rating	IP30
Operating temperature	–20 ... +60 °C (–4 ... +140 °F)
Operating humidity	0–90 %RH, non-condensing
Storage temperature	–20 ... +60 °C (–4 ... +140 °F)

Compliance

Electromagnetic compatibility (EMC)	IEC/EN 61326-1, industrial environment
Electrical safety	IEC/EN 61010-1
API0C model	
Radio standards and approvals	China MIIT 工业和信息化部公告 2019 年第 52 号
Compliance marks	China RoHS
API0E model	
EU directives and regulations	RoHS Directive (2011/65/EU) as amended by 2015/863 Radio Equipment Directive, RED (2014/53/EU)
Radio standards and approvals	ETSI EN 300 220-2 ETSI EN 301 489-1 ICASA No: TA 2020-7918 IMDA No: DB105576 TDRA No: ER36051/24 Serbia: W005 21
Compliance marks	AAA, CE, ICASA, UKCA
API0A model	
Radio standards and approvals	Anatel ID: 04763-19-12322 AS/NZS 4268 FCC ID: 2AO39-API0A IC ID: 23830-API0A NOM ID: 1901C00393
Compliance marks	ANATEL, NOM, NYCE, RCM
API0J model	
Radio standards and approvals	MIC ID: 012-200006
Compliance marks	GITEKI
API0K model	
Radio standards and approvals	KC ID: R-R-ys8-API0
Compliance marks	KC
API0T model	
Radio standards and approvals	NCC ID: CCAP21LP1250T6
Compliance marks	NCC

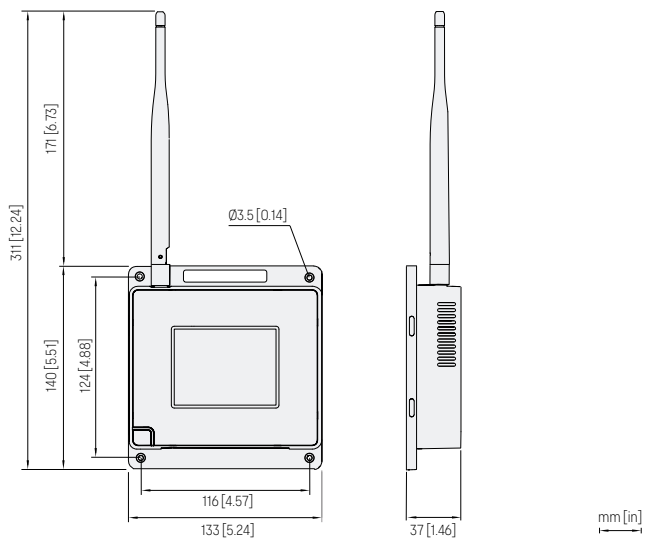

AP10 access point dimensions

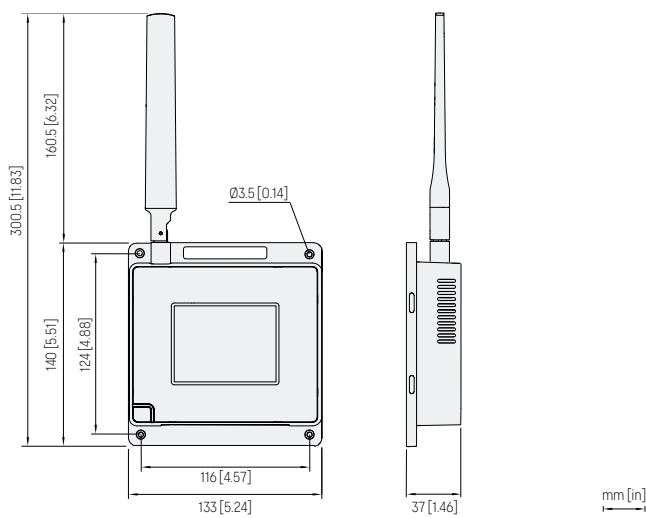

AP10C model dimensions

Mechanical specifications

Housing color	White
Mounting methods	Screws, tie wrap
Weight	386 g (13.62 oz)

Dimensions (H × W × D)

AP10C model	300.5 × 133 × 37 mm (11.83 × 5.24 × 1.46 in)
Other models	311 × 133 × 37 mm (12.24 × 5.24 × 1.46 in)

Materials

Housing	PC/ABS blend
Display window	Chemically strengthened glass
Antenna	ABS



Features

- Industry-leading measurement precision
- Interchangeable high-accuracy probes for T, RH, and CO₂
- 30-day memory buffer
- Typical battery life of 18 months in RH and T measurement
- Uses standard AA batteries
- Probe calibrations are traceable to SI units through national metrology institutes or accredited calibration laboratories
- Cost-effective alternative to chart recorders

RFL100 Data Logger uses Vaisala's proprietary VaiNet wireless technology. It can be used to monitor temperature (T), relative humidity (RH), and carbon dioxide level (CO₂) in a wide range of environments. The combination of wireless connectivity and selection of measurement probes enables a variety of applications, including measurements in warehouses, museums, production areas, cleanrooms, laboratories, incubators, cold storage areas, and freezers.

VaiNet wireless

RFL100 connects wirelessly through the AP10 VaiNet Wireless Access Point to Vaisala monitoring systems for real-time trends, alarms, and historical reporting. VaiNet wireless technology provides a robust wireless signal that is extremely reliable over long distances and in complex, obstructed conditions. This wireless technology allows the data logger's signal to travel over 100 m (approx. 330 ft) indoors without the aid of signal amplifiers or repeaters. Wireless communications are encrypted to ensure data integrity and security.

Measurements are updated and stored every 60 seconds, and sent from the data logger every 4 minutes. In case of temporary network disruptions, the data logger can record up to 30 days of measurements that are automatically transmitted to the monitoring system when communications are restored. Recorded data can also be downloaded directly from RFL100 through the USB port.

Versatility and convenience

RFL100 requires no startup configuration, and the included mounting bracket supports several installation methods. Detailed custom display shows the latest measurement results, alarm and battery status, and signal strength of the current access point connection. The housing is classified IP54 to protect the device from dust and cleaning.

RFL100 is powered by two standard AA size 1.5 V batteries (LR6 alkaline or FR6 lithium) for 18 months of operation at approximately 20 °C (68 °F) in RH and T measurement. When fresh batteries are inserted during yearly calibration, battery replacement between calibrations is not needed. External power is required for CO₂ measurement, with the batteries serving as backup in case the external power becomes unavailable.

Interchangeable probes

The probes are detachable and easy to switch out for calibration. The monitoring system detects the changed probe information automatically and maintains accurate and complete historical records. RH and T probes use Vaisala HUMICAP® humidity sensors and platinum temperature sensors (Pt100 and Pt1000 type) for superior stability. Probes can be integrated with the RFL100 housing or connected using a cable.

CO₂ measurement is provided by the GMP251 probe that uses Vaisala's patented, latest-generation CARBOCAP® technology with exceptional stability. The probe automatically compensates the CO₂ measurement according to ambient temperature.

Probe options

Probe	Description ¹⁾	Installation notes
HMP110, HMP110T, and HMP110REF 	<p>Humidity and temperature probe for measurement in demanding conditions. Robust stainless steel construction. Temperature-only version HMP110T available.</p> <p>Plastic grid filter provides the fastest response time. For added protection, select the membrane filter, the PTFE filter, or the stainless steel sintered filter.</p> <p>Operating temperature range -40 ... +80 °C (-40 ... +176 °F).</p>	<p>Suitable for measurement inside chambers, incubators, fridges, and freezers.</p> <p>Versatile mounting options using accessories.</p> <p>Must be connected to RFL100 using a cable.</p> <p>A constant output probe version HMP110REF is also available for validating installations. The constant output version does not measure - instead, it outputs unchanging humidity and temperature values.</p>
HMP63, HMP63T, HMP115 and HMP115T 	<p>Humidity and temperature probes for general purpose measurement. HMP63T and HMP115T are temperature-only versions. A calibration certificate is not included with HMP63 and HMP63T.</p> <p>Plastic grid filter provides the fastest response time. For added protection, select the membrane filter or the PTFE filter.</p> <p>Operating temperature range -40 ... +60 °C (-40 ... +140 °F).</p>	<p>Ideal choice for ambient measurement.</p> <p>Can be integrated with the RFL100 housing or connected using a cable.</p>
TMP115 	<p>Temperature probe for measurement in a wide range of conditions.</p> <p>Available as 50 cm (1 ft 7.7 in) and 3 m (9.8 ft) long versions. Length includes the probe body and sensor tip.</p> <p>Temperature measurement range -196 ... +150 °C (-320 ... +302 °F).</p> <p>Operating temperature range of the probe body is -40 ... +60 °C (-40 ... +140 °F).</p>	<p>Suitable for measurement inside chambers, fridges, and freezers.</p> <p>Can be integrated with the RFL100 housing or connected using a cable.</p> <p>Sensor tip withstands immersion in glycol and liquid nitrogen.</p> <p>Use the thermal dampener block accessory (item code 236310SP) to add thermal mass to the sensor tip.</p>
GMP251 	<p>Carbon dioxide probe for %-level measurements. Designed for use in demanding applications such as life science incubators.</p> <p>Operating temperature range -40 ... +60 °C (-40 ... +140 °F).</p> <p>When ordered with the RFL100 data logger, the probe is delivered with a mounting kit that includes a probe holder designed for use with GMP251 and the other supported probes. The kit also includes a magnetic holder for the Probe Splitter M8/M12 accessory.</p>	<p>Must be connected using the Probe Splitter M8/M12 accessory. Any one of the other supported probes can be connected at the same time in the M8 connector of the probe splitter.</p> <p>Requires use of external power supply due to power consumption. Data logger batteries provide a backup in case the external power is not available.</p> <p>Note that the logged temperature data of all probes is limited to range -40 ... +60 °C (-40 ... +140 °F) when GMP251 is connected.</p>

¹⁾ See [probe datasheets at docs.vaisala.com](https://docs.vaisala.com) for detailed probe specifications.

Accessories

Accessories

Accessory ¹⁾	Item code
Mounting kit with screws (4 pcs), wall plugs (4 pcs), and cable ties (2 pcs)	245679SP
Probe cable for RFL100, 1.5 m	CBL210555-1M5SP
Probe cable for RFL100, 3 m	CBL210555-3MSP
Probe cable for RFL100, 10 m	CBL210555-10MSP
Flat cable for RFL100, 3 m	CBL210647SP
Probe holder (5 pcs) for Ø 12 mm probes	ASM213382SP
CO ₂ probe mounting kit	ASM214253SP
Probe splitter M8 (for connecting two T probes)	CBL210834SP
Probe splitter M8/M12 (for connecting a CO ₂ probe)	CBL211050SP
1 m high-temperature cable M12 (for CO ₂ probe) ²⁾	271038SP
1 m high-temperature cable M8 (for RH/T probe in CO ₂ applications) ²⁾	271039SP
Universal power supply (100–240 V AC / 5 V DC) with micro-USB connector	ASM214178SP

1) See [probe datasheets at docs.vaisala.com](https://docs.vaisala.com) for probe-specific accessories.

2) High-temperature cables are extensions for the probe splitter M8/M12 in CO₂ applications. They tolerate –20 ... +180 °C (–4 ... +356 °F) temperatures and can remain inside an incubator during a typical heat sterilization cycle. Due to heat conduction, leave half of the cable in ambient temperature when installed.



RFL100 with two TMP115 probes (left) and with HMP110 and GMP251 probes (right)

Technical data

Wireless

Networking standards	Vaisala VaiNet
Modulation	Chirp spread spectrum modulation
Output power	≤ 13 dBm (≤ 20 mW)
Antenna	Internal
Typical range (indoors) ¹⁾	At least 100 m (approx. 330 ft)
Range with line-of-sight	Over 500 m (1640 ft)
Frequency bands	500 MHz, 868 MHz, 915 MHz, 920 MHz, 921 MHz, and 922 MHz

¹⁾ Attaching the data logger directly to an interfering barrier, for example a metal surface, will reduce the range of the radio signal and typical range may not be achieved.

Memory

Sample capacity	30 days (43200 samples per channel)
Memory type	Non-volatile EEPROM
Memory mode	Ring buffer (FIFO)
Sampling rate	One sample / channel / minute (non-changeable)

General

Compatible probes	GMP251, HMP63, HMP63T, HMP110, HMP110T, HMP115, HMP115T, TMP115
Batteries	2 × AA sized, 1.5 V (LR6 or FR6)
Operation time on battery power at 20 °C (68 °F)	
RH and T measurement in any probe combination	18 months
CO ₂ measurement	Typically 12 hours with lithium batteries

Compatibility requirements

Item	Required minimum version(s)
Vaisala monitoring system ¹⁾	<ul style="list-style-type: none"> viewLinc Enterprise Server 5.0 viewLinc Cloud (any version) Jade Smart Cloud (any version)
viewLinc Cloud compatibility	<ul style="list-style-type: none"> RFL100 firmware 1.8.0 API0 firmware 5.1.0
Jade Smart Cloud compatibility	<ul style="list-style-type: none"> RFL100 firmware 1.10.0 API0 firmware 5.4.0
Dual T probe support using Probe Splitter M8 accessory	<ul style="list-style-type: none"> RFL100 firmware 1.2.0 API0 firmware 3.0 viewLinc Enterprise Server 5.0.2
CO ₂ measurement using Probe Splitter M8/M12 accessory and external power	<ul style="list-style-type: none"> RFL100 firmware 1.4.0 RFL100 hardware manufactured after July 2021 API0 firmware 4.0 and hardware revision G viewLinc Enterprise Server 5.1

¹⁾ See product datasheets at docs.vaisala.com for more information.

Operating environment

Storage temperature	-40 ... +60 °C (-40 ... +140 °F)
Operating humidity	0-100 %RH, non-condensing
IP rating	IP54
IP rating with external power supply	IP20
Operating temperature ¹⁾	
with alkaline batteries	+2 ... +60 °C (+35.6 ... +140 °F)
with lithium batteries	-20 ... +60 °C (-4 ... +140 °F)
with external power supply	+0 ... +60 °C (+32 ... +140 °F)

¹⁾ Verify operating temperature specification when using third party batteries and power supplies.

Compliance

Electromagnetic compatibility (EMC)	IEC/EN 61326-1, industrial environment
Electrical safety	IEC/EN 61010-1
500 MHz model	
Radio standards and approvals	China MIIT 工业和信息化部公告 2019 年第 52 号
Compliance marks	China RoHS
868 MHz model	
EU directives and regulations	RoHS Directive (2011/65/EU) as amended by 2015/863 Radio Equipment Directive, RED (2014/53/EU)
Radio standards and approvals	ETSI EN 300 220-2 ETSI EN 301 489-1 ICASA No: TA 2020-7761 IMDA No: DB105576 TDRA No: ER36050/24 Serbia: W005 21
Compliance marks	AAA, CE, ICASA, UKCA
915 MHz model	
Radio standards and approvals	Anatel ID: 04761-19-12322 AS/NZS 4268 FCC ID: 2AO39-RFL100A IC ID: 23830-RFL100A NOM ID: 1901C00493
Compliance marks	ANATEL, NOM, NYCE, RCM
920 MHz model	
Radio standards and approvals	MIC ID: 012-200007
Compliance marks	GITEKI
921 MHz model	
Radio standards and approvals	KC ID: R-R-ys8-RFL100
Compliance marks	KC
922 MHz model	
Radio standards and approvals	NCC ID: CCAP21LP1240T3
Compliance marks	NCC

Mechanical specifications

Housing color	White
Mounting methods	Screws, cable ties, hook, or magnetic mounting bracket (optional accessory)
Probe interface	4-pin female M8 connector
Service port	USB 2.0 with micro-USB connector

Dimensions (H × W × D) with HMP115 probe

Without mounting bracket	158 × 62 × 31 mm (6.22 × 2.4 × 1.22 in)
With mounting bracket	186 × 68 × 36.5 mm (7.32 × 2.68 × 1.44 in)

Weight

With batteries (2 pcs alkaline) and HMP115 probe	190 g (6.7 oz)
With batteries (2 pcs alkaline), HMP115 probe, and magnetic mounting bracket	254 g (8.96 oz)

Materials

Housing	PC/ABS blend
Display window	PMMA (acrylic)
Sealings	TPE

Requirements for external power supply

Output voltage	5 V DC
Output power	Min. 1 W
Output connector	Micro-USB
Certifications and approvals	<ul style="list-style-type: none"> • Certified to IEC 62368-1 • Approved for use in your country

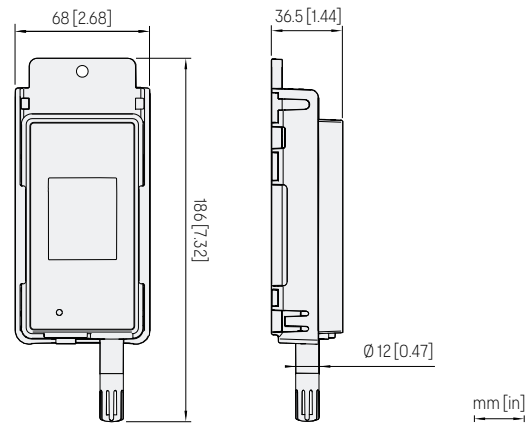

RFL100 dimensions with HMP115 probe



Features

- Optimized for fast transfer of measurement and alarm data
- 2 probe ports
- Records and displays up to 4 parameters
- PoE (Power over Ethernet) and battery backup
- Local memory buffer for a minimum of 30 days of data
- Ethernet connection to Vaisala viewLinc Enterprise Server software
- Easy configuration with Insight PC software using USB-C connection

VDL200 is an Ethernet-connected data logger for continuous monitoring systems. It provides high-accuracy measurements from up to 2 detachable humidity, temperature, and carbon dioxide probes. VDL200 also supports the ANP115 Analog Input Probe for recording and display of measurements from analog and boolean signals. Suitable applications include real-time measurements in environments where wired connections are preferred. VDL200 is compatible with the Vaisala viewLinc Enterprise Server software and Jade Smart Cloud monitoring solution.

Ease of deployment

VDL200 has a versatile mounting bracket that supports installation using screws, cable ties, or the included magnet. Connected probes are detected at startup, and measurement parameters are automatically selected for display and data logging.

VDL200 is powered by PoE (Power over Ethernet), and secured with a battery backup. VDL200 uses commonly available AA size 1.5 V alkaline (LR6) and lithium (FR6) batteries.

Only minimal configuration is needed to connect the VDL200 to its host system. Typically only the address of the host system must be set, and possibly the network settings must be configured according to the local network requirements. When the data logger is accepted to the host system, it automatically identifies the connected devices and the available parameters – manual configuration is not needed.

VDL200 has a USB-C service port for on-site access to configuration settings. To connect, you need a USB-C cable and the Insight PC software for Windows®. For more information, see vaisala.com/insight.

Ease of use

The display and status LED on the data logger show the measurement and connectivity status of the data logger at a glance. All 4 measurement parameters and their units fit on the display at the same time.

Connected VDL200 data loggers can be remotely managed from the host system.

Gap-free data

If the VDL200 loses connection with its host system, it continues to measure and display data, and store the data in its local memory. When the connection is restored, the locally stored data is quickly uploaded to the host system.

In case of a power outage, the data logger continues to record data to its local memory using the battery backup. The battery type and measurement probe combination determine how long the battery backup lasts.

Interchangeable probes

VDL200 utilizes external, interchangeable Vaisala measurement probes. Probes can be replaced with factory calibrated ones as part of an applicable service, or they can be calibrated on the spot. Probe calibration information is automatically updated to the host system, and can be used to remind the system administrator to take action when calibration is due.

Probe options

Probe	Description ¹⁾	Installation notes
HMP110 and HMP110T 	<p>Humidity and temperature probe for measurement in demanding conditions. Robust stainless steel construction. Temperature-only version HMP110T is also available.</p> <p>Measurement temperature range $-40 \dots +80 \text{ }^{\circ}\text{C}$ ($-40 \dots +176 \text{ }^{\circ}\text{F}$).</p> <p>When ordered with VDL200 data logger, HMP110 and HMP110T probes are equipped with the membrane filter. For other filter types that are available as separately ordered accessories, see HMP60 and HMP110 Series User Guide (M211060EN).</p>	<p>Suitable for measurement inside chambers, incubators, fridges, and freezers. Versatile mounting options using accessories.</p> <p>A magnetic probe holder (item code ASM213382) is included when the probe is ordered with VDL200.</p> <p>Must be connected to VDL200 using a suitable cable. A 3 m M8/M8 probe cable (item code CBL211293-3MSP) is included when the probe is ordered with VDL200.</p>
HMP115 and HMP115T 	<p>Humidity and temperature probe for general purpose measurement. Temperature-only version HMP115T is also available.</p> <p>Operating temperature range $-40 \dots +60 \text{ }^{\circ}\text{C}$ ($-40 \dots +140 \text{ }^{\circ}\text{F}$).</p> <p>When ordered with VDL200 data logger, HMP115 and HMP115T probes are equipped with the membrane filter. For other filter types that are available as separately ordered accessories, see HMP60 and HMP110 Series User Guide (M211060EN).</p>	<p>Ideal choice for ambient measurement.</p> <p>Can be connected to VDL200 directly or using an M8/M8 probe cable (for example, CBL211293-3MSP).</p>
TMP115 	<p>Temperature probe for measurement in a wide range of conditions.</p> <p>Available as 50 cm (1 ft 7.7 in) and 3 m (9.8 ft) long versions. Length includes the probe body and sensor tip.</p> <p>Measurement temperature range $-196 \dots +150 \text{ }^{\circ}\text{C}$ ($-320 \dots +302 \text{ }^{\circ}\text{F}$).</p> <p>Operating temperature range of the probe body is $-40 \dots +60 \text{ }^{\circ}\text{C}$ ($-40 \dots +140 \text{ }^{\circ}\text{F}$).</p>	<p>Suitable for measurement inside chambers, fridges, and freezers. Sensor tip withstands immersion in glycol and liquid nitrogen.</p> <p>Can be connected to VDL200 directly or using an M8/M8 probe cable (for example, CBL211293-3MSP).</p> <p>Use the thermal dampener block accessory (item code 236310SP) to add thermal mass to the sensor tip.</p>
GMP251 and GMP252 	<p>Carbon dioxide probes for %-level measurements (GMP251) and ppm-level measurements (GMP252). Designed for use in demanding applications such as life science incubators.</p> <p>Operating temperature range $-40 \dots +60 \text{ }^{\circ}\text{C}$ ($-40 \dots +140 \text{ }^{\circ}\text{F}$).</p> <p>When ordered with VDL200 data logger, the probe is delivered with an M8/M12 adapter cable (item code CBL211291SP) and the CO₂ probe mounting kit (item code ASM214253SP). The kit includes a probe holder that has attachments for the CO₂ probe, a \varnothing 12 mm probe (for example, HMP110) and the sensor tip of the TMP115 probe.</p>	<p>Must be connected to VDL200 using an M8/M12 adapter cable (for example, the included flat cable CBL211291SP).</p>
ANP115 and ANP115C 	<p>ANP115 is a single channel analog input probe for converting the voltage or current output of an analog sensor into a digital output. The channel can be configured as generic boolean input for use as an alarm switch, for example. ANP115 has open wires by default, but it can also be ordered with an M8 field connector kit.</p> <p>ANP115C model with a door switch is also available.</p>	<p>ANP115 must be configured before installation using Insight PC software and Vaisala USB cable (item code 219690).</p> <p>ANP115C is pre-configured and does not require additional configuration.</p> <p>Can be connected to VDL200 directly or using an M8/M8 probe cable (for example, CBL211293-3MSP).</p>

¹⁾ See [probe datasheets in docs.vaisala.com](https://docs.vaisala.com) for detailed probe specifications.

Accessories

VDL200 accessories

Description	Item code
Mounting kit with screws (4 pcs), wall plugs (4 pcs), and cable ties (2 pcs)	245679SP
PoE power source, Europe	CMS-ACC-POE-EUR
PoE power source, UK	CMS-ACC-POE-UK
PoE power source, US	CMS-ACC-POE-US
USB-A – USB-C cable for service port connection, 2 m	273956
Probe cable for VDL200, M8-4M – M8-4F, 3 m	CBL211293-3MSP
Probe cable for VDL200, M8-4M – M8-4F, 10 m	CBL211293-10MSP
Flat probe cable for VDL200, M8-4M – M8-4F, 3 m	CBL211292SP
Flat probe cable for VDL200, M8-4M – M12-5F, 3 m	CBL211291SP
High-temperature cable, M12-5M – M12-5F, 1 m ^{1) 2)}	271038SP
High-temperature cable, M8-4M – M8-4F, 1 m ²⁾	271039SP

1) For CO₂ probe. Connect to VDL200 using M8-M12 adapter cable CBL211291SP.

2) High-temperature cables tolerate –20 ... +180 °C (–4 ... +356 °F) temperatures and can remain inside an incubator during a typical heat sterilization cycle. To minimize heat conduction, leave half of the cable in ambient temperature when installed.

Selected probe-specific accessories

Description ¹⁾	Compatible probes	Item code
Thermal dampener block for 3/16" probes (4.8 mm)	TMP115	236310SP
Probe holder (5 pcs) for Ø 12 mm probes	ANP115, HMP110/T, HMP115/T, TMP115	ASM213382SP
CO ₂ probe mounting kit	GMP251, GMP252	ASM214253SP
Sintered PTFE filter	HMP115/T	219452SP

1) See [probe datasheets in docs.vaisala.com](https://docs.vaisala.com) for more accessories.

Technical data

Compatible probes

Measurement or function	Probe models
Humidity and temperature (RH+T)	HMP110, HMP115
Temperature (T)	HMP110T, HMP115T, TMP115
Carbon dioxide (CO ₂)	GMP251, GMP252
Analog input and door switch	ANP115, ANP115C

Compatible systems and software

System or software	Version	Connection
viewLinc Enterprise Server	Version 5.2.1 or above	TCP port 8883 (default)
Jade Smart Cloud	Any	TCP port 443
Insight PC software	Version 1.3.0 or above	USB-C
Time server ¹⁾	Any	UDP port 123

¹⁾ Connection to Network Time Protocol (NTP) server is required for operation.

Inputs and outputs

Ethernet connector	8P8C (RJ-45)
Probe connector (2 pcs)	4-pin female M8 connector
Service port	USB-C
Ethernet interface	
Supported standards	10BASE-T, 100BASE-TX
IPv4 address assignment	DHCP (automatic), static IP

Operating environment

Operating environment	Indoor use
Use in wet location	No
Storage temperature	-30 ... +60 °C (-22 ... +140 °F)
Operating temperature	-20 ... +60 °C (-4 ... +140 °F)
Operating humidity	0-100 %RH, non-condensing
IP rating	IP30
Do not place the VDL200 unit in an environment that can exceed this specification, for example inside a climate chamber. Insert only the measurement probe(s) in the chamber and leave the VDL200 unit outside it.	

Powering

Powering options	Power over Ethernet (PoE) Battery backup ¹⁾ USB-C for temporary service use
PoE supply voltage	48 V DC
USB-C supply voltage	5 V DC
Power consumption	Max. 2 W
Battery type	AA size, 1.5 V, LR6 (alkaline) or FR6 (lithium)
Number of batteries	4
Typical operating time on battery power at +20 °C (+68 °F)	
RH and T measurement combinations	2 weeks with alkaline batteries
CO ₂ measurement or analog input	24 hours with lithium batteries

¹⁾ Network connection is not available when VDL200 is operating on battery power.

Data logging and user interface specifications

Number of samples ¹⁾	50 000
Sampling rate	1 min
Minimum recording span	30 days
Memory type	Flash
Memory mode	Ring buffer (FIFO)
Display	3.16" reflective matrix display
Display languages	English
Interaction	2 capacitive buttons

¹⁾ 1 sample can include up to 4 measurement values.

Compliance

EU directives and regulations	EMC Directive (2014/30/EU) RoHS Directive (2011/65/EU) as amended by 2015/863
Electromagnetic compatibility (EMC)	IEC/EN 61326-1, industrial environment EN 61000-6-2 EN 61000-6-4 FCC part 15 B, Class B ICES-3 / NMB-3 (Class B)
Compliance marks	CE, China RoHS, KC, RCM

Mechanical specifications

Housing color	RAL 9003 (white)
Mounting methods	Screws, cable ties, or magnet
Dimensions without probes (H × W × D)	120 × 100 × 38 mm (4.72 × 3.94 × 1.50 in)
Display size (H × W)	68 × 42 mm (2.68 × 1.65 in)
Weight without batteries and probes	260 g (9.17 oz)
Materials	
Housing	PBT plastic
Display window	PMMA (acrylic)
Mounting bracket	PC/ABS plastic blend

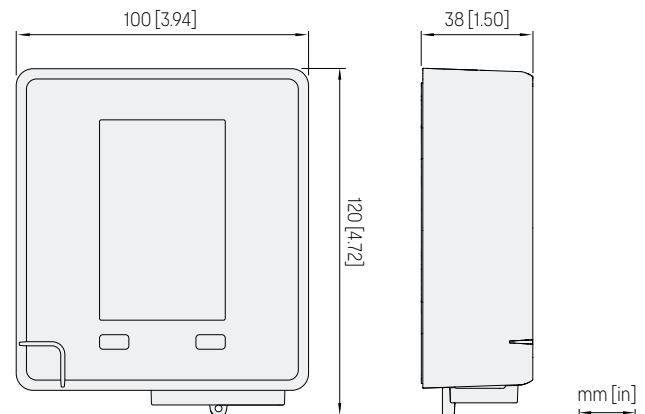

VDL200 dimensions

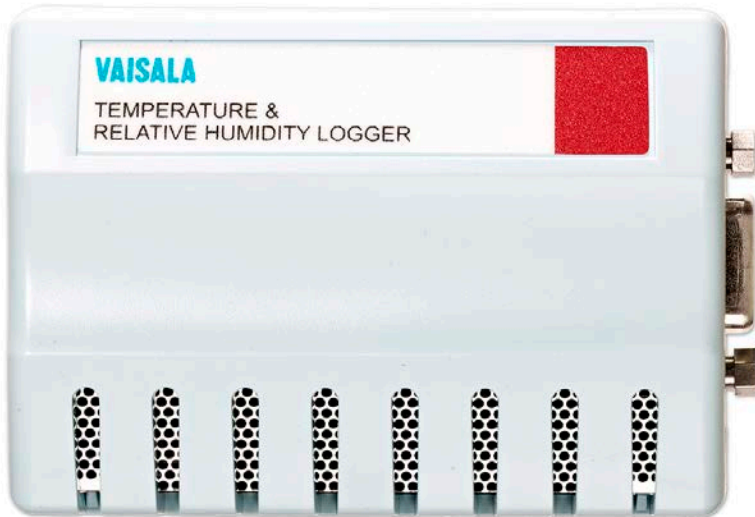

Features

- Industry-leading temperature and relative humidity measurement precision
- High accuracy, adjustable timebased digital recording
- Printed reports for any time period
- 10-year battery
- Ability to perform validation and continuous monitoring with the same model
- Traceable to SI units through national metrology institutes
- Superior alternative to chart recorders and hard-wired systems
- Integrated high-accuracy RH sensor

Vaisala's 2000 series of data loggers are designed to provide high accuracy measurements for temperature, relative humidity and an analog sensor of your choice.

The 2000 logger combines internal temperature and RH sensors with optional external channels for either current or voltage inputs for recording parameters such as differential pressure, CO₂, level, particles, or conductivity. The 2000 logger can also include a Boolean channel for door switches or alarm contacts. The 2000 logger includes calibrations traceable to SI units through national metrology institutes.¹⁾

Ideal for use in standalone or networked applications, the 2000 data logger connects directly to a PC with USB, or installs to an existing network via

Ethernet, Power over Ethernet, or WiFi. Each data logger contains a 10-year battery and onboard memory for recording at the point of measurement. With autonomous power and recording capacity, data is immune to network and power interruptions.

The DL2000 data loggers can be used with Vaisala software, either viewLinc or vLog, to download, display, and analyze environmental data. The viewLinc monitoring system provides 24/7

multi-stage alarm notification, remote, real-time monitoring and gap-free data. The vLog software is a simple solution for validation/ mapping applications. The measurement results are traceable to the international system of units (SI) through national metrology institutes (NIST USA, MIKES Finland, or equivalent) or ISO/IEC 17025 accredited calibration laboratories.

All reports are customizable and can be exported to spreadsheets and PDF to provide records that meet the requirements of 21 CFR Part 11 and Annex 11.

¹⁾ The measurement results are traceable to the international system of units (SI) through national metrology institutes (NIST USA, MIKES Finland, or equivalent) or ISO/IEC 17025 accredited calibration laboratories.

Technical Data

General

Size	85 × 59 × 26 mm (3.4 × 2.3 × 1 in)
Weight	76 g (2.7 oz.)
Interfaces	RS-232 serial, USB, WiFi, Ethernet and Power over Ethernet (vNet)
Mounting	3M Dual Lock™ fasteners
Power source	Internal 10-year lithium battery (Battery life specified at +23 °C with sample interval of 1 min or longer)
Internal clock	Accuracy ±1 min/month at -25 °C ... +70 °C (-13 ... +158 °F)
Electromagnetic compatibility	FCC Part 15 and CE EN 50581:2012 EN 55032:2012/AC:2013 Class B EN 61326-1:2013
RoHS compliance	2011/65/EU
PC Software	
Monitoring, alarming and reporting	viewLinc
Validation/mapping GxP environments	vLog VL for validated vLog SP for non validated
Adding loggers to an existing OPC-compatible monitoring system	OPC Server

Channel Configuration and Recording Span

Model	Channel Types			
	CH 1	CH 2	CH 3	CH 4
2000-20R	T	RH		
2000-3CR	T	RH	4 ... 20 mA	
2000-35R	T	RH	0 ... 5 VDC	
2000-3AR	T	RH	0 ... 10 VDC	
2000-4BR	T	RH	Boolean	Boolean
Number of Channels Enabled¹⁾				
Sample Interval	1	2	3	4
10 seconds	14.1 days	7.1 days	4.7 days	3.5 days
1 minute	2.8 months	1.4 months	23.8 days	21.2 days
5 minutes	1.2 years	7.1 months	4.7 months	3.5 months
15 minutes	3.5 years	1.7 years	1.2 years	10.6 months
1 hour	13.9 years	7.0 years	4.6 years	3.5 years

1) Temperature channel must be enabled when the RH channel is enabled.

Memory

Sample capacity	122 197 12-bit samples
Memory type	Non-volatile EEPROM
Memory modes	User-selectable wrap (FIFO) or stop when memory is full. User-selectable start and stop times.
Sampling rates	User-selectable from once every 10 seconds to once a day.

Current Loop and Voltage Inputs

Input Type	Current Loop	Analog Voltage
Available ranges	0 ... 22 mA	0 ... 5 VDC, 0 ... 10 VDC
Resolution	5.5 µA	0.025 % F.S.
Accuracy	±0.15 % F.S. at +25 °C (+77 °F)	±0.15 % F.S. at +25 °C (+77 °F)
Input impedances	75 Ω ¹⁾	>1 MΩ
Isolation	One common per logger	One common per logger
Overload protection	40 mA max. (reverse-polarity protected)	±24 VDC max. (reverse-polarity protected)

1) Termination resistance plus approximately 0.4 volt drop through a protection diode.

Internal Sensors

Internal Temperature Sensor	
Calibrated measurement range ¹⁾	-25 ... +70 °C (-13 ... +158 °F)
Operating range	-35 ... +85 °C (-31 ... +185 °F)
Initial accuracy ²⁾	
± 0.10 °C over +20 °C ... +30 °C (± 0.18 °F over +68 °F ... +86 °F)	
± 0.20 °C over -25 °C ... +70 °C (± 0.36 °F over -13 °F ... +158 °F)	
One Year Accuracy ³⁾	
± 0.15 °C over +20 °C ... +30 °C (± 0.27 °F over +68 °F ... +86 °F)	
± 0.25 °C over -25 °C ... +70 °C (± 0.45 °F over -13 °F ... +158 °F)	
Resolution	0.02 °C at +25 °C (0.04 °F at +77 °F)
Internal RH Sensor	
Calibrated measurement range ¹⁾	45 %RH at +10 °C (+50 °F) 10 ... 80 %RH at +25 °C (+77 °F) 45 %RH at +45 °C (+113 °F)
Operating range	0 ... 100 %RH (non-condensing)
Initial accuracy ²⁾	
± 1 %RH over 10 ... 80 %RH at +20 ... +30 °C (+68 ... +86 °F)	
± 1.5 %RH over 80 ... 90 %RH at +20 ... +30 °C (+68 ... +86 °F)	
± 2 %RH over 10 ... 90 %RH at -20 ... +70 °C (-4 ... +158 °F)	
One year accuracy ³⁾	
± 2 %RH over 10 ... 90 %RH at +20 ... +30 °C (+68 ... +86 °F)	
± 3 %RH over 10 ... 90 %RH at -20 ... +70 °C (-4 ... +158 °F)	
Resolution	0.05 %RH

1) Custom calibration points available upon request including full ICH coverage.

2) Initial accuracy includes all known influence quantities present at the time of calibration including calibration uncertainty, mathematical fit, data logger resolution, hysteresis and reproducibility.

3) One Year Accuracy includes all known influence quantities present during the operation of a data logger over the course of one year including Initial Accuracy and Long Term Drift. Not included is any drift related to atypical contamination or misuse.



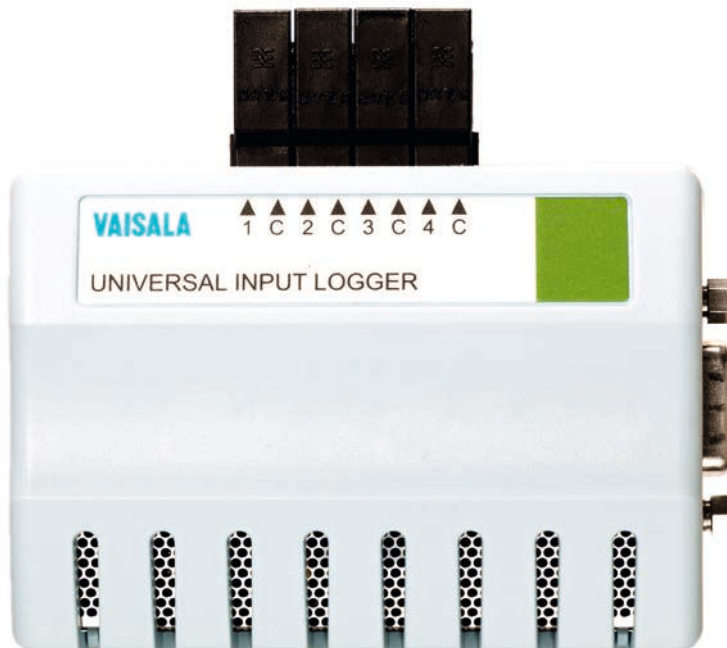

Features

- 10-year battery and large onboard memory
- Single and multi-channel models with up to four input channels
- Easily set scaling and measurement units for recording
- Time-based digital recording in a range of sample intervals
- Multiple connectivity options - USB, Ethernet, WiFi
- Optional vNet cradle for Ethernet or Power over Ethernet connectivity
- Traceable to SI units through national metrology institutes.
- Two year limited warranty

DL4000 series of data loggers are designed to interface with a wide range of transducers, transmitters, and sensors with a DC voltage or 0 - 20 mA current loop output.

DL4000 is a simple solution for recording and monitoring pressure, flow, fluid level, PH, electrical properties, moisture and gas concentrations.

Ideal for use in standalone or networked applications, the DL4000 Universal Input logger connects directly to a PC with USB or installs to an existing network via Ethernet, Power over Ethernet or WiFi. Each logger contains a 10-year battery and onboard memory for recording a wide range of variables at the point of measurement. With autonomous power and recording capacity, data is immune to network and power interruptions.

The DL4000 data loggers can be used with Vaisala software, either viewLinc or vLog, to download, display, and analyze environmental data. The viewLinc monitoring system provides 24/7 multi-stage alarm notification, remote, real-time monitoring and gap-free data. The vLog software is a simple solution for validation/mapping applications. The DL4000 data loggers include calibrations traceable to SI units through national metrology institutes.¹⁾

All reports are customizable and can be exported to spreadsheets and PDF to provide records that meet the requirements of 21 CFR Part 11 and Annex 11.

Choose the DL4000 VL series data logger for GxP-compliant environments and the DL4000 SP series for non-GxP applications.

¹⁾ Measurement results are traceable to the international system of units (SI) through national metrology institutes (NIST USA, MIKES Finland, or equivalent) or ISO/IEC 17025 accredited calibration laboratories.

Technical Data

General specifications

Operating range	-40 ... +85 °C (-40 ... +185 °F) and 0 ... 100 %RH (non-condensing)
Interfaces	RS-232 serial USB Wifi module Ethernet and Power over Ethernet (vNet)
Weight	76 g (2.7 oz)
Size	85 × 59 × 26 mm (3.4 × 2.3 × 1 in)
Mounting	3M Dual Lock™ fasteners
PC software	Graphing & Reporting Software vLog SP for SP-series vLog VL for VL-series viewLinc for continuous monitoring & alarming OPC Server to add on to existing OPC compatible monitoring systems
Internal clock	Accuracy ±1 min/month at -25 ... +70 °C (-13 ... +158 °F)
Electromagnetic compatibility	FCC Part 15 and CE EN 50581:2012 EN 55032:2012/AC:2013 Class B EN 61326-1:2013
RoHS compliance	2011/65/EU
Power source	Internal 10-year lithium battery (Battery life specified with sample interval of 1 min or longer)

Memory specifications

Memory type	Non-volatile EEPROM
Data sample capacity	120 000 12-bit samples
Memory modes	User-selectable wrap (FIFO) or stop when memory is full. User-selectable start and stop times.
Sampling rates	User-selectable from once every 10 seconds to once a day. (Battery life specified with sample interval of 1 min or longer)
Recording span	Recording span depends upon sample interval selected and number of channels enabled. Please see table above.

Recording span

	1	2	3	4
10 seconds	13.8 days	6.9 days	4.6 days	3.4 days
1 minute	2.7 months	1.3 months	27.7 days	20.8 days
5 minutes	1.1 years	6.9 months	4.6 months	3.4 months
15 minutes	3.4 years	1.7 years	1.1 years	10.4 months
1 hour	13.6 years	6.8 years	4.5 years	3.4 years

Current loop and voltage inputs

Available ranges	0 ... 20mA	0 ... 5 V DC, 0 ... 10 V DC
Resolution	5.5 µA	0.025 % F.S.
Accuracy	±0.15 % F.S. at +25 °C (+77 °F)	±0.15 % F.S. at +25 °C (+77 °F)
Input impedances	75 Ω	> 1 MΩ
Isolation	One common per logger	One common per logger
Overload protection	40 mA max. (reverse-polarity protected)	±24 V DC max. (reverse-polarity protected)

Channel configurations

4000-405	0 ... 5 V DC
4000-40A	0 ... 10 V DC
4000-40C	0 ... 20 mA



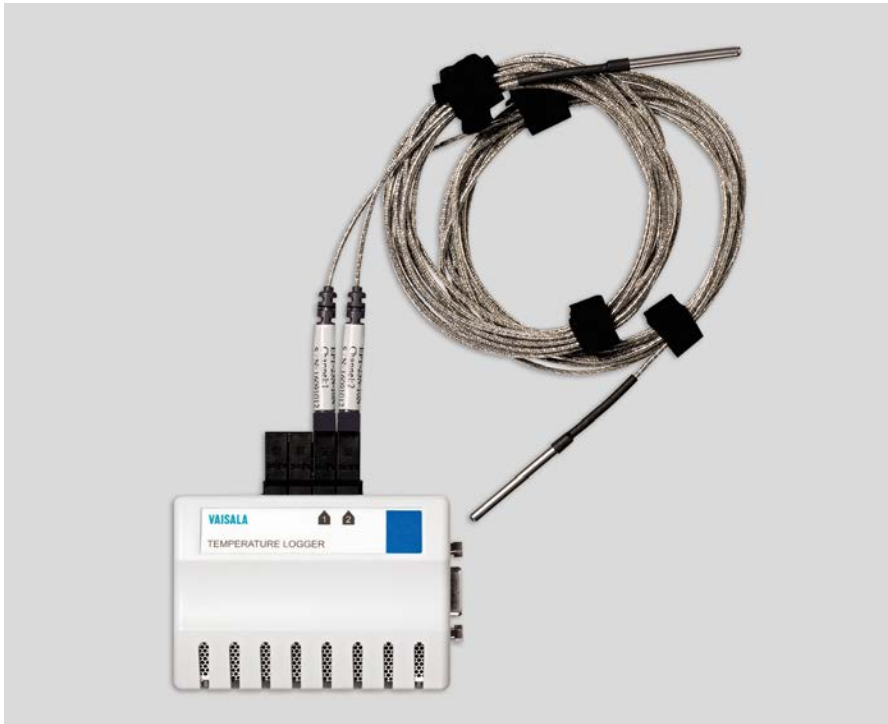

Features

- Industry-leading precision and accuracy
- Printed reports for any time period
- Internal battery with up to 10 years' lifetime
- Validation and continuous monitoring with the same model
- 2-year limited warranty
- Superior alternative to chart recorders and hard-wired systems
- Timebase calibrated over the operating temperature range
- Adjustable time-based recording
- Snap-in logger cradle for easy network connectivity
- Two probe options give high accuracy – from $-90\text{ }^{\circ}\text{C}$ to $+70\text{ }^{\circ}\text{C}$ ($-130\text{ }^{\circ}\text{F}$ to $+158\text{ }^{\circ}\text{F}$)
- Traceable to SI units through national metrology institutes

The DL1000-1400 temperature data loggers include the VL series for regulated environments and the SP series for non FDA/GxP regulated industries.

Suitable for validated and standard precision monitoring

Validatable data loggers, together with Vaisala software solutions, provide a superior, high accuracy solution for use in FDA/GxP regulated environments by ensuring tamperproof files and electronic records that meet 21 CFR Part 11 requirements.

The DL1000-1400 temperature data loggers include calibrations traceable to SI units through national metrology institutes.¹⁾

DL data loggers are compatible with the browser-based Vaisala viewLinc continuous monitoring software. viewLinc provides 24/7 multi-stage alarm notification and remote monitoring, and is suitable for regulated environments.

Additional software options include vLog VL for regulated environments and vLog SP for standard precision monitoring. vLog software solutions allow downloading, displaying, analyzing, and reporting of recorded environmental data.

Applications

The DL1000-1400 temperature data loggers are ideal for monitoring and validation of:

- Refrigerators and freezers (to $-90\text{ }^{\circ}\text{C}$ ($-130\text{ }^{\circ}\text{F}$))
- Incubators
- Stability chambers
- Warehouses
- Ambient conditions

Autonomous power and recording capacity

Each data logger contains a battery²⁾ and onboard memory for recording at the point of measurement. With autonomous power and recording capacity, data is immune to network and power interruptions.

1) Measurement results are traceable to the international system of units (SI) through national metrology institutes (NIST USA, MIKES Finland, or equivalent) or ISO/IEC 17025 accredited calibration laboratories.

2) Expected battery lifetime up to 10 years in typical use.

Technical data

General specifications

Interfaces	<ul style="list-style-type: none"> Internal: RS-232 serial With additional connectors/devices: USB, Ethernet, Wi-Fi, PoE
PC software	<ul style="list-style-type: none"> vLog software for graphing and reporting (vLog SP for SP series and vLog VL for VL series) viewLinc Enterprise Server software for continuous monitoring and alarming OPC DA Server to add Vaisala recorders to any OPC-compatible monitoring system
Internal clock	Accuracy ±1 min/month -25 °C ... +70 °C (-13 °F ... +158 °F)
Logger operating/ Storage range	-40 °C ... +85 °C (-40 °F ... +185 °F) 0 ... 100 %RH non-condensing
Power source	Internal lithium battery with typical lifetime of 10 years ¹⁾

1) Typical battery lifetime specified with sample interval of 1 min or longer.

Mechanical specifications

Size	85 × 59 × 26 mm (3.4 × 2.3 × 1 in)
Weight	76 g (2.7 oz)
Mounting	3M Dual Lock™ fasteners Snap-in connector locks provide secure probe connections

Internal temperature sensor

1000-21x series	Precision-tolerance epoxy-encapsulated NTC thermistor
-----------------	---

Memory

1000-2XX series	48 100 12-bit samples
1400-44X series	85 300 12-bit samples
Memory type	Non-volatile EEPROM
Memory modes	User selectable: wrap (FIFO) or stop when memory is full. User selectable start time. User selectable stop time (VL series only).
Sampling rates	User-selectable (in 10-second intervals) from once every 10 seconds to once a day.

Compliance

EU directives and regulations	EMC Directive (2014/35/EU) RoHS Directive (2011/65/EU) as amended by 2015/863
Electromagnetic compatibility (EMC)	IEC/EN 61326-1, industrial environment
EMC emissions	CISPR 32 / EN 55032, Class B FCC part 15 B, Class B
Compliance marks	CE, China RoHS, RCM

Recording span: 1000-2xx

Sample interval	Number of channels enabled	
	1	2
10 seconds	5.5 days	2.7 days
1 minute	1.1 months	16.7 days
5 minutes	5.5 months	2.7 months
15 minutes	1.3 years	8.3 months
1 hour	5.4 years	2.7 years



Data logger model VL-1000-21x



Data logger model VL-1000-22x

Technical data

Recording span: 1400-44x

Sample interval	Number of channels enabled			
	1	2	3	4
10 seconds	9.8 days	4.9 days	3.2 days	2.4 days
1 minute	1.9 months	29.6 days	19.7 days	14.8 days
5 minutes	9.8 months	4.9 months	3.2 months	2.4 months
15 minutes	2.4 years	1.2 years	9.8 months	7.4 months
1 hour	9.7 years	4.8 years	3.2 years	2.4 years



Data logger model VL-1400-44x

EPT series temperature probes

Sensor models	
"N" range external probes	EPT-23N-XXN and EPT-22W-XXN
Operating/storage range	-40 °C ... +95 °C (-40 ... +203 °F)
Connector color code	Black
"V" range external probes	EPT-23N-XXV and EPT-22W-XXV
Operating/storage range	-95 °C ... +95 °C (-139 ... +203 °F)
Connector color code	Blue
Sensor tips	
EPT-23N-XXX	Stainless steel Diameter 3.2 mm (0.13 in) Length 38 mm (1.5 in)
EPT-22W-XXX (liquid submersible)	Sealed Teflon® tip Diameter 3 mm (0.12 in) Length 28 mm (1.1 in)
Probe lengths	3 m (10 ft) and 7.6 m (25 ft)
Cable construction	2 mm (0.08 in) diameter Teflon® coated cable

Temperature probe accessories

Thermal dampening block, for use in refrigerators and freezers, simulates a glycol bottle to reduce viewLinc alarms generated by opening and closing a door.



EPT - XXX - XXX

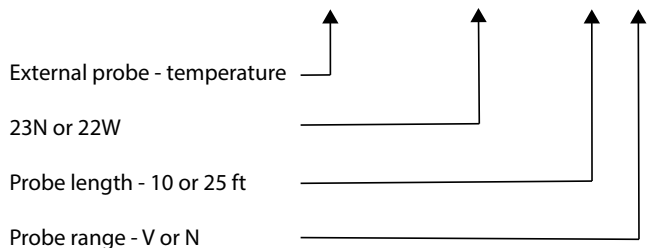

Technical data

Temperature range and accuracy

Internal sensor

Calibrated measurement range -25 ... +70 °C (-13 ... +158 °F)

Operating/storage range -40 ... +85 °C (-40 ... +185 °F)

0 ... 100 %RH non-condensing

Initial accuracy ¹⁾ ±0.10 °C over +20 ... +30 °C
(±0.18 °F over +68 ... +86 °F)
±0.20 °C over -25 ... +70 °C
(±0.36 °F over -13 ... +158 °F)

1-year accuracy ²⁾ ±0.15 °C over +20 ... +30 °C
(±0.27 °F over +68 ... +86 °F)
±0.25 °C over -25 ... +70 °C
(±0.45 °F over -13 ... +158 °F)

External probes - all models

"N" range external probe

Calibrated measurement range -25 ... +70 °C (-13 ... +158 °F)

Operating/storage range -40 ... +95 °C (-40 ... +203 °F)

Initial accuracy ^{1) 3)} ±0.10 °C over +20 ... +30 °C
(±0.18 °F over +68 ... +86 °F)
±0.20 °C over -25 ... +70 °C
(±0.36 °F over -13 ... +158 °F)

1-year accuracy ^{2) 3)} ±0.20 °C over +20 ... +30 °C
(±0.36 °F over +68 ... +86 °F)
±0.25 °C over -25 ... +70 °C
(±0.45 °F over -13 ... +158 °F)

Resolution 0.02 °C at +25 °C (0.04 °F at +77 °F)

"V" range external probe

Operating/storage range -95 ... +95 °C (-139 ... +203 °F)

Initial accuracy ^{1) 3)} ±0.20 °C over -90 ... -40 °C
(±0.36 °F over -130 ... -40 °F)

1-year accuracy ^{2) 3)} ±0.25 °C over -90 ... -40 °C
(±0.45 °F over -130 ... -40 °F)

Resolution 0.02 °C at -80 °C (0.04 °F at -112 °F)

Calibrated measurement range -90 ... -40 °C (-130 ... -40 °F)

- ¹⁾ Initial accuracy includes all known influence quantities present at the time of calibration including calibration uncertainty, mathematical fit, data logger resolution, hysteresis, and reproducibility.
²⁾ 1-year accuracy includes all known influence quantities present during the operation of a data logger over the course of 1 year including initial accuracy and long term drift. Not included is any drift related to atypical contamination or misuse.
³⁾ Specification for external channels is for a probe calibrated to the specific channel of the data logger and with the data logger at -25 °C ... +70 °C (-13 °F ... +158 °F).

Product part number legend

Guide for reading the product tables and selecting the most appropriate model for your application.

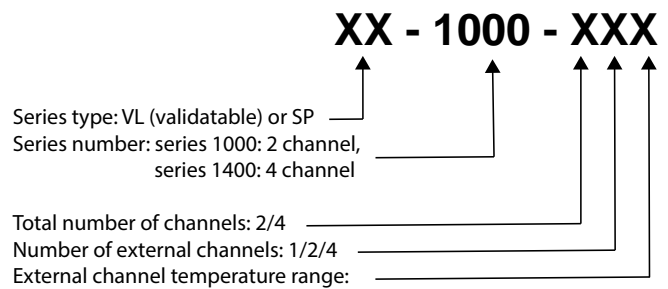

DL1016-1416 Multi-application Temperature Data Logger

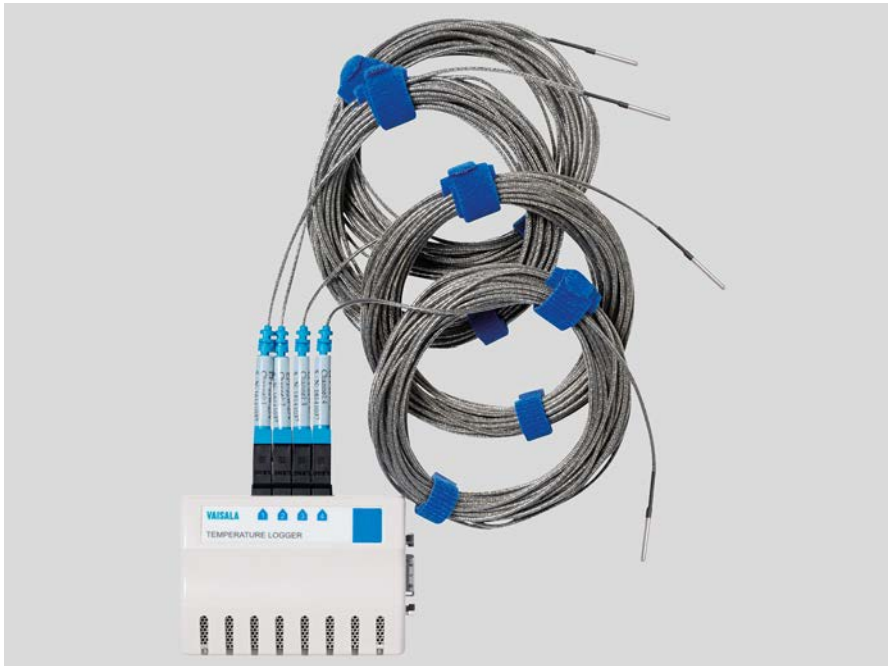

Features

- Industry-leading precision and accuracy
- Real-time monitoring & alarming with viewLinc software
- Reliable validation/mapping with vLog software
- Easy connectivity to your existing network – wired or wireless
- Validation and continuous monitoring with the same data logger
- Superior alternative to chart recorders and hard-wired systems
- Traceable to SI units through national metrology institutes

Vaisala's multi-application temperature data loggers monitor temperatures in up to four applications with one logger – ultra-low temperature freezers, freezer/refrigerators and incubators.

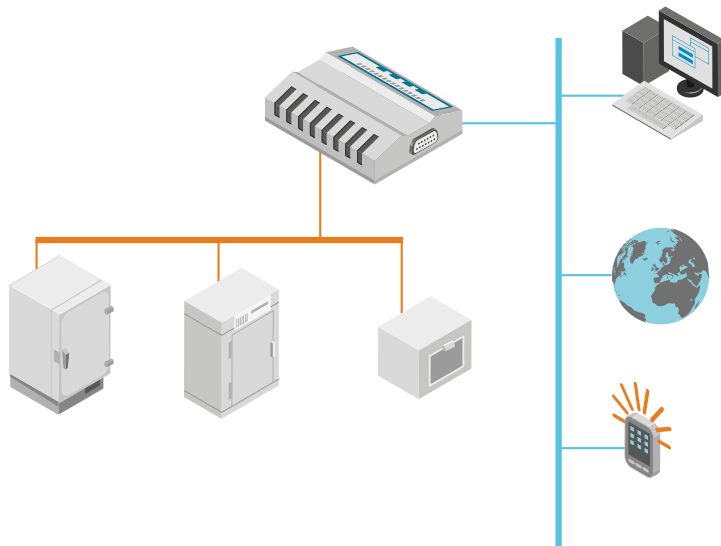

DL1016-1416 data loggers include calibrations traceable to SI units through national metrology institutes.¹⁾

Choose the DL1016-1416 VL series data logger for GxP-compliant environments and the DL1016-1416 SP series for non-GxP applications.

Model numbers and channels

- VL-1016-22V: Two external channels for validatable applications
- VL-1416-44V: Four external channels for validatable applications
- SP-1016-22V: Two external channels
- SP-1416-44V: Four external channels

DL1016-1416 data loggers can be used with Vaisala software, either viewLinc or vLog, to download, display, and analyze environmental data.

The viewLinc monitoring system provides 24/7 multi-stage alarm notification, remote, real-time monitoring and gap-free data.

The vLog software is a simple solution for validation/mapping applications. All reports are customizable and can be exported to spreadsheets and PDF to provide records that meet the requirements of 21 CFR Part 11 and Annex 11.

¹⁾ Measurement results are traceable to the international system of units (SI) through national metrology institutes (NIST USA, MIKES Finland, or equivalent) or ISO/IEC 17025 accredited calibration laboratories.

Technical data

General specifications

Interfaces	<ul style="list-style-type: none"> Internal: RS-232 serial With additional connectors/devices: USB, Ethernet, Wi-Fi, PoE
Software	<ul style="list-style-type: none"> vLog software for graphing and reporting viewLinc Enterprise Server software for continuous monitoring and alarming OPC Server to add Vaisala recorders to any OPC-compatible monitoring system
Internal clock accuracy	±1 min/month 0 ... +50 °C (+32 ... +122 °F)
Power source	Lithium battery with typical lifetime of 10 years ¹⁾

¹⁾ Typical battery life specified with sample interval of 1 min or longer.

Measurement performance

Sensor	"V" Range External Probe
Calibrated measurement range	-90 ... +50 °C (-130 ... +122 °F)
Operating range	-95 ... +70 °C (-139 ... +158 °F)
Initial accuracy ¹⁾	±0.25 °C over -90 ... +50 °C (±0.45 °F over -130 ... +122 °F)
One year accuracy ¹⁾	±0.35 °C over -90 ... +50 °C (±0.63 °F over -130 ... +122 °F)
Resolution	0.01 °C at +25 °C (0.02 °F at +77 °F)

¹⁾ Specification for external channels is for a probe calibrated to the specified channel of the data logger, with the logger at 0 °C to +50 °C (+32 °F to +77 °F).

Memory

1016 Series	68 600 16-bit samples
1416 Series	101 375 16-bit samples
Memory type	Non-volatile EEPROM
Memory modes and sampling rates	User-selectable rates from once every 10 seconds to once per day (with sample interval of ≥1 min)

Operating environment

Operating temperature	0 ... +50 °C (+32 ... +122 °F)
Operating humidity	0 ... 100 %RH non-condensing
Storage temperature	-40 ... +85 °C (-40 ... +185 °F)
Storage humidity	0 ... 100 %RH non-condensing

Recording span: 1016-22V

Sample interval	Number of channels enabled	
	1	2
1 minute	1.5 months	23.8 days
5 minutes	7.6 months	3.8 months
15 minutes	1.9 years	11.5 months
1 hour	7.8 years	3.9 years

Recording span: 1416-44V

Sample interval	Number of channels enabled			
	1	2	3	4
1 minute	2.3 months	1.1 months	23.5 days	17.6 days
5 minutes	11.3 months	5.6 months	3.7 months	2.8 months
15 minutes	2.8 years	1.4 years	11.3 months	8.5 months
1 hour	11.5 years	5.7 years	3.8 years	2.8 years

Thermistor probes

Sensor	"V" range external probe
Operating temperature	-95 ... +70 °C (-139 ... +158 °F)
Connector color code	Blue
Probe length	3 m (10 ft) and 7.6 m (25 ft) lengths available
Cable construction	2 mm (0.07 in) diameter, Teflon coated cable

Stainless steel sensor tip

Diameter	3.2 mm (1/8 in)
Length	38 mm (1.5 in)

Sealed Teflon sensor tip

Diameter	3 mm (0.12 in)
Length	28 mm (1.1 in)

Mechanical specifications

Dimensions	85 × 59 × 26 mm (3.4 × 2.3 × 1 in)
Weight	76 g (2.7 oz)
Mounting	3M Dual Lock™ fasteners Snap-in connector locks provide secure probe connections

Compliance

EU directives and regulations	EMC Directive (2014/30/EU) RoHS Directive (2011/65/EU) as amended by 2015/863
Electromagnetic compatibility (EMC)	EN 61326-1, industrial environment
EMC emissions	EN 55032:2012/AC:2013 Class B
Compliance marks	CE, FCC Part 15

Spare parts and accessories

Immersion/Dry probes	
Thermistor V range probe 25 ft	235139SP
Thermistor V range probe 10 ft	235218SP
Thermistor immersion V range probe 25 ft	235140SP
Thermistor immersion V range probe 10 ft	235217SP
Temperature probe accessories	
Thermal dampening block, for use in refrigerators and freezers. The block simulates a glycol bottle to reduce alarms generated by opening and closing a door.	EPT-TDB-2



Designed for Controlled Environments

- Extreme temperatures
- Liquid nitrogen (LN₂)
- Ovens
- Sterilization chambers

The Vaisala DL1700 series data loggers provide highly accurate temperature data acquisition and are ideal for demanding environments. The DL1700 data loggers can be used with Vaisala software, either viewLinc or vLog, to download, display, and analyze environmental data.

Applications

- Ideal for extreme temperatures from -240 °C to +1760 °C
- Accepts type J, K, T, E, R and S thermocouples
- No programming or complicated equations required
- Highly accurate replacement for bulky data acquisition systems
- Traceable to SI units through national metrology institutes

The viewLinc monitoring system provides 24/7 multi-stage alarm notification, remote, real-time monitoring and gap-free data. The vLog software is a simple solution for validation/ mapping applications. All reports are customizable and can be exported to spreadsheets and PDF to provide records that meet the requirements of 21 CFR Part 11 and Annex 11.

Easy to use with standard thermocouples, these compact data loggers can offer up to five channels of data in temperatures ranging from -240 °C to +1760 °C.

We offer models for both validated and non-validated applications. Choose the DL1700 VL series for GxP-compliant environments and the DL1700 SP series for non-validated applications.

DL1700 series data loggers include calibrations traceable to SI units through national metrology institutes.¹⁾

¹⁾ Measurement results are traceable to the international system of units (SI) through national metrology institutes (NIST USA, MIKES Finland, or equivalent) or ISO/IEC 17025 accredited calibration laboratories.

Technical Data

General

Interfaces	RS-232 serial, USB, Ethernet, WiFi network interface available
Internal clock	Accuracy: ± 1 min./month at $-25 \dots +70$ °C
Software	viewLinc for Monitoring, Alarming and Reporting vLogVL for Validation/ Mapping GxP environments vLogSP for graphing and reporting non-GxP environments OPC Server to add Vaisala loggers to any OPC- compatible monitoring system

Temperature Accuracy

	Temperature Measurement Range	Accuracy at Mid-range	Resolution at Mid-range
Type K	$-220 \dots +1370$ °C ($-364 \dots +2498$ °F)	± 1.3 °C (± 2.3 °F)	0.37 °C (0.67 °F)
Type J	$-130 \dots +900$ °C ($-202 \dots +1652$ °F)	± 1.0 °C (± 1.8 °F)	0.29 °C (0.52 °F)
Type T	$-240 \dots +350$ °C ($-400 \dots +662$ °F)	± 1.2 °C (± 2.2 °F)	0.34 °C (0.61 °F)
Type E	$-110 \dots +740$ °C ($-166 \dots +1364$ °F)	± 0.70 °C (± 1.3 °F)	0.20 °C (0.36 °F)
Type R	$-50 \dots +1760$ °C ($-58 \dots +3200$ °F)	± 4.4 °C (± 7.9 °F)	1.3 °C (2.3 °F)
Type S	$-50 \dots +1700$ °C ($-58 \dots +3092$ °F)	± 5.1 °C (± 9.2 °F)	1.5 °C (2.7 °F)

Operating Environment

Operating temperature	$-40 \dots +85$ °C ($-40 \dots +185$ °F)
Operating humidity	0 ... 100 %RH (non-condensing)
EMC compliance	FCC Part 15 and CE EN 50581:2012 EN 55032:2012/AC:2013 Class B EN 61326-1:2013
RoHS compliance	2011/65/EU

Mechanical Specifications

Dimensions	85 × 59 × 26 mm (3.4 × 2.1 × 1 in)
Weight	60 g (2.7 oz)
Mounting	3M Dual Lock™ fasteners
Power source	Internal 10-year lithium battery (Battery life specified with sample interval of 1 min. or longer)

Cold Junction Temperature Channel

Measurement range	$-40 \dots +85$ °C ($-40 \dots +185$ °F)
Accuracy	± 0.25 °C over $+20 \dots +30$ °C (± 0.45 °F over $+68 \dots +86$ °F) ± 0.35 °C over $-25 \dots +70$ °C (± 0.63 °F over $-13 \dots +158$ °F)

Data Logger Inputs

1700 Model	Number of Channels Enabled		
	Thermocouple	CJT	Total
170-54T	4	1	5

Note: One channel is designated for Cold Junction Temperature (CJT) reference using an on-board precision-tolerance thermistor.

Thermocouple Input Channels

Compatible Thermocouple Types: J, K, T, E, R, S	
Initial Accuracy	
Input range	$-7.2 \dots +55.4$ mV
Resolution	0.016 mV
Initial Accuracy	± 0.042 mV at $+25$ °C ($+77$ °F)
Input Impedance: 10M Ω	
Input range	$-7.2 \dots +55.4$ mV
Resolution	0.016 mV
1-Year Accuracy	± 0.055 mV at $+25$ °C ($+77$ °F)
Additional Error	
At 3 V/m RF field from 450 MHz ... 580 MHz	± 0.350 mV
At 3 V conducted RF from 3 MHz ... 80 MHz	± 1.0 mV

Memory

Memory type	Non-volatile EEPROM
Data sample capacity	135,165 12-bit samples
Memory modes	User-selectable wrap (FIFO) or stop when memory is full. User-selectable start time.
Sampling rates	User-selectable from once every 10 seconds to once a day. (Battery life specified with sample interval of 1 min. or longer)
Recording span	Recording span depends upon sample interval selected and number of channels enabled.

Spare Parts and Accessories

Thermocouple probe	EPT-22T-20T
Type	T
Conductors	Copper/Constantan
Operating range	$-200 \dots +200$ °C ($-328 \dots +392$ °F)
Length	6.096 m (20 ft)
Error	± 1 °C ... ± 1.5 %



Mid-range Data Loggers

For temperature, humidity, and contact channel measurement



Designed for controlled environments

- Drug discovery, R&D
- Early phase clinical trials
- Blood and tissue banks
- Hospitals and pharmacies
- Nutraceutical manufacturing
- Food and dietary supplement applications
- Aerospace
- Semiconductors
- Museums and archives

Vaisala Mid-range Data Loggers are designed for early phase drug and device development applications where speed and economy are critical. The MR loggers can be used with Vaisala software to monitor and analyze environmental data and provide presentation-quality records that are easily exported to PDF and spreadsheets.

Simplified calibration

Easy to install and configure, the MR loggers are calibrated with an abbreviated process that provides reliable accuracy in operating environments between -55 to $+50$ °C (-67 to 122 °F).

The MR loggers include calibrations traceable to SI units through national metrology institutes to ensure cGMP, ISO 9000, and HACCP quality standards.¹⁾ Optional services are available, including extended warranties and onsite calibration.

Easy configuration

Additional connectivity devices enable data transfer with several options, including USB, wireless, and Power over Ethernet with the vNet PoE network interface. When MR loggers are used with the vNet PoE device, installation takes minutes. With the vNet device, loggers are automatically identified on your network by the software.

Lean validation

For applications that require validation, we offer efficient and practical protocols that allow for quick verification of data logger functions. For information on IQOQ documents, see www.vaisala.com/gamp-gxp-validation.

Software options

Whether you need multistage alarming sent via text, email, PC display, or dial-out, or to perform a comprehensive mapping study, Vaisala has user-friendly software designed for use in regulated environments, including:

- viewLinc Continuous Monitoring and Alarming
- vLogSP for Validation/Mapping applications

Data logger options

Six versions of the MR loggers are available with up to four channels of temperature-only, temperature + humidity, or Boolean contact channel for door switches/alarm contact recording:

- DL1000MR - 1 internal temperature channel
- DL1016MR - 2 channel temperature with probes
- DL1016MRB - 2 channel with 1 temperature probe, and 1 contact input
- DL1416MR - 4 channel temperature with probes
- DL1416MRB - 2 channel temperature with probes, and 2 contact inputs
- DL2000MR - 2 internal channels temperature and RH

¹⁾ Measurement results are traceable to the International System of units (SI) through national metrology institutes (NIST USA, MIKES Finland, or an equivalent) or ISO/IEC 17025 accredited calibration laboratories.

Technical data

General

Interfaces	RS-232 serial, Ethernet, USB, Wi-Fi, vNet PoE network interface
Software	<ul style="list-style-type: none">• vLog Validation/Mapping• viewLinc Continuous Monitoring & Alarming• OPC DA Server to add Vaisala loggers to any OPC compatible monitoring system
Internal clock accuracy	±1 min/month 0 to +50 °C (+32 to +122 °F)
Power source	Lithium battery with typical lifetime of 10 years ¹⁾

¹⁾ Typical battery life specified with sample interval of 1 min or longer.

Memory

Memory type	Non-volatile EEPROM
Memory mode	User-selectable wrap (FIFO) or stop when memory is full
Sampling rates	User-selectable rates from once every 10 seconds to once per day (Typical battery life specified with sample interval of 1 min or longer)
Data sample capacity	
DL1000MR	48 100 12-bit samples
DL1016MR/MRB	68 600 16-bit samples
DL1416MR/MRB	101 375 16-bit samples
DL2000MR	122 197 12-bit samples

Mechanical specifications

Dimensions	85 × 59 × 26 mm (3.4 × 2.3 × 1 in)
Weight	76 g (2.7 oz)
Mounting	3M Dual Lock™ Fasteners Snap-in connector for secure probe connections

Temperature sensors

Internal sensor type	Precision-tolerance epoxy encapsulated NTC thermistor
Cable construction	2 mm (0.07 in) diameter, Teflon coated cable

External temperature probes

Sensor tip	Stainless steel
Diameter	3.2 mm (1/8 in)
Length	38 mm (1.5 in)

Probe cable lengths

DL1016MR/MRB	3 m (10 ft)
DL1416MR/MRB	7.6 m (25 ft)

Compliance

EU directives and regulations	EMC Directive (2014/30/EU) RoHS Directive (2011/65/EU) as amended by 2015/863
Electromagnetic compatibility (EMC)	EN 61326-1, industrial environment
EMC emissions	EN 55032:2012/AC:2013 Class B
Compliance marks	CE, FCC Part 15

Technical data

DL1000MR internal temperature sensor

Range and accuracy

Logger operating range	-35 ... +85 °C (-31 ... +185 °F)
Calibrated measurement range	-25 ... +70 °C (-13 ... +158 °F)
Resolution	0.02 at +25 °C (0.04 at +77 °F)
Accuracy over temperature range at -25 ... +70 °C (-13 ... +122 °F) ¹⁾	±0.5 °C (±0.9 °F)

¹⁾ Initial accuracy includes all known influence quantities present at the time of calibration including calibration uncertainty, mathematical fit, data logger resolution, hysteresis and reproducibility. Not included is any drift related to atypical contamination or misuse.

DL2000MR internal temperature/RH sensor

Temperature range and accuracy

Operating range	-35 ... +85 °C (-31 ... +185 °F)
Calibrated measurement range	-25 ... +70 °C (-13 ... +158 °F)
Accuracy over temperature range at -25 ... +70 °C (-13 ... +122 °F) ¹⁾	±0.5 °C (±0.9 °F)
Resolution	0.02 °C at +25 °C (0.04 °F at +77 °F)

Relative humidity range and accuracy

Calibrated measurement points	<ul style="list-style-type: none"> • 45 %RH at +10 °C (+50 °F) • 10 %RH and 80 %RH at +25 °C (+77 °F) • 45 %RH at +25 °C (+77 °F) • 45 %RH at +45 °C (+113 °F)
Operating range	0 ... 100 %RH (non-condensing)
Temperature range +20 ... +30 °C (68 ... 86 °F)	10 ... 90 %RH ±2.0 %RH
Temperature range -20 ... +20 °C, +30 ... +70 °C (-4 ... 68 °F, 86 ... 158 °F)	10 ... 90 %RH ±3.0 %RH
Resolution	0.05 %RH
Humidity sensor	HUMICAP [®] 180R
Stability	±2 %RH over 2 years

¹⁾ Initial accuracy includes all known influence quantities present at the time of calibration including calibration uncertainty, mathematical fit, data logger resolution, hysteresis and reproducibility. Not included is any drift related to atypical contamination or misuse.

DL1016/1416MR external temperature sensors

Range and accuracy

Logger operating range	0 ... +50 °C (32 ... +122 °F)
Probe operating range	-95 ... +70 °C (-139 ... +158 °F)
Calibrated measurement range	-55 ... +50 °C (-130 ... +122 °F)
Resolution	0.01 °C at +25 °C (0.02 °F at +77 °F)
Accuracy over temperature range at -55 ... +50 °C (-67 ... +122 °F) ¹⁾	±0.5 °C (±0.9 °F)

¹⁾ Specification for external channels is for a probe calibrated to the specified channel of the data logger, with the logger at 0 °C to +50 °C (32 °F to +122 °F).

Accessories

Thermal dampening block, for use in refrigerators and freezers. The block simulates a glycol bottle to reduce alarms generated by opening and closing doors.	EPT-TDB
Cable with magnetic contact switch (7.6 m (25 in)) for use with MRB loggers	EPT-DS-25



Features

- Eliminates the cost of wiring AC power to each monitored point
- Data loggers can be installed wherever a LAN cable can be run
- Increased data communication protection from power outage because the server room's UPS can provide backup power
- Plug and Play connectivity when using viewLinc Aware function

Wherever reliable network communications and cost are important, more companies are using Power over Ethernet (PoE) devices. Vaisala vNet PoE network interface brings easy connectivity with Vaisala DL series data loggers at a lower cost than alternative networking devices.

The snap-in design streamlines data logger connectivity into a small footprint, eliminating wires between normally separate data loggers and PoE devices. When power and data are carried over the same cable, you can also eliminate the cost of installing an AC power source.

vNet PoE integrates VL and SP data loggers without compromising their high accuracy. It brings greater flexibility and simplicity to the deployment of Vaisala Continuous Monitoring system.

The viewLinc Aware function in viewLinc monitoring software allows you to quickly configure data loggers, alone or in batches. Simply place data loggers in a vNet cradle, connect to a Local Area Network, and viewLinc discovers and configures the data loggers.

vNet PoE interface comes in four models:

- CDL-VNET-P with a fan inside the cradle for data loggers with an internal temperature channel
- CDL-VNET-LP without a fan for data loggers without an internal temperature channel
- CDL-VNET-PC with 15 V output to power external sensors and transmitters; includes internal fan
- CDL-VNET-LPC with 15 V output to power external sensors and transmitters; without internal fan

There is also an option to power the interface with AC. Select the model that fits your application to monitor and record temperature, humidity, CO₂, differential pressure, door switches, and many other parameters.

Technical Data

Measurement performance

Heating effect on measurements

CDL-VNET-P and CDL-VNET-PC	Temperature rise from electronics (important only for data loggers with internal sensors): < 0.05 °C as seen by the data logger sensor
CDL-VNET-LP and CDL-VNET-LPC	Not to be used for data loggers with internal sensors

Operating environment

Operating temperature	-25 ... +70 °C (-13 ... +158 °F)
Storage temperature	-40 ... +85 °C (-40 ... +185 °F)
Operating humidity	0 ... 90 %RH (non-condensing and not to exceed a mixing ratio of 38.5 g/kg)

Inputs and outputs

Ethernet connectivity	IEEE 802.3af (Class 1) ¹⁾ , bandwidth 10Base-T
Connectivity cable	Category 5/5e RJ-45 connector 1.83 m (6 ft)
Operating voltage ²⁾	12 ... 30 V DC Plugs into vNet jack labeled 12 V

Output voltage

CDL-VNET-P and CDL-VNET-LP	Not available
CDL-VNET-PC and CDL-VNET-LPC	Nominal: 15 V DC Maximum: 350 mW

Power consumption

CDL-VNET-P and CDL-VNET-LP	Typical: 625 mW Maximum: 700 mW
CDL-VNET-PC and CDL-VNET-LPC	Typical: 900 mW Maximum: 1.35 W

Power supply ³⁾

North America	12 V DC / 0.5 A max. out 120 V AC in
International	12 V DC / 1.66 A max. out 100 ... 240 V AC in

1) Max. PSE power reservation is 4.00 W.

2) Optional for use without PoE.

3) Included but not required when using PoE.

Mechanical specifications

Dimensions (H × W × L)	43 × 102 × 102 mm (1.7 × 4.0 × 4.0 in)
Weight	180 g (6.3 oz)

General specifications

Data logger compatibility	v6.00 hardware and higher Includes models VL and SP 1000, 1700, 1200, 1016, 1416, 1400, 2000, 4000
LED indicators	Link, activity, power, data logger communications
Device configuration	HTTP Web Interface PC-based configuration wizard
viewLinc Aware	Requires one vNet to be programmed with the viewLinc server IP address. Other vNets on the subnet will automatically self-configure.
Addressing	DHCP/RARP ARP-Ping Static IP for IP address assignment Net BIOS name
Firmware	Field upgradable firmware
Compliance	
Emissions/Immunity	FCC Part 15 and CE EN 50581:2012 EN 55032:2012/AC:2013 Class B EN 61326-1:2013
Conformity	RoHs, 2011/65/EU WEEE

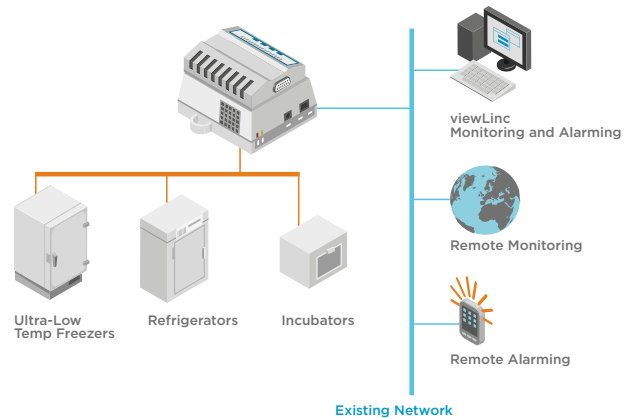

Indigo510 Transmitter

For Vaisala Indigo-compatible probes



Features

- Touchscreen display (optional non-display model with LED indicator also available)
- Data logging of all measurement parameters
- IP66 rated metal enclosure
- 2 configurable galvanically isolated analog outputs
- Ethernet connection with web interface and optional Vaisala cloud connectivity for remote monitoring
- Modbus[®] TCP/IP protocol
- Protective extra-low voltage powering
- UL Listed in USA and Canada

Vaisala Indigo510 Transmitter is an industrial-grade, robust transmitter that accommodates 1 Vaisala Indigo-compatible probe for humidity, temperature, dew point, carbon dioxide, hydrogen peroxide, and moisture in oil measurements. The transmitter can display measurements on the spot as well as transmit them to automation systems through analog signals or Modbus TCP/IP protocol.

Variety of probe options

The Indigo500 series transmitters are the most versatile option for use with Indigo-compatible probes.

- HMP series humidity and temperature probes
- DMP series dew point probes
- GMP250 series carbon dioxide probes
- HPP270 series vaporized hydrogen peroxide probes
- MMP8 moisture in oil probe

The probes are interchangeable, self-contained measurement instruments that are easily detachable from the transmitter for calibration and maintenance. The probes are connected using a cable that can be extended with a standard instrumentation cable to allow up to 30 m (98 ft) distance between the transmitter and the probe.

The Indigo500 series transmitters can be connected to the MHT410 transmitter for display of measurement data and automation system connectivity.

Through the transmitter service port, the Indigo500 series transmitters can also be connected to the free Vaisala Insight PC Software or Indigo80 Handheld Indicator.

For more information on the Indigo product family, see vaisala.com/indigo.

Analog and digital interfaces

The Indigo510 transmitter has 2 analog channels that can be configured to mA or voltage type. Any of the output parameters from the connected probe can be assigned to control the analog channels.

The digital output protocol is Modbus TCP/IP over Ethernet. The Ethernet connection also provides a web interface and cybersecurity that meets modern standards. The Indigo500 series transmitters can be ordered with a possibility for Vaisala cloud connection for remote monitoring.

Robust design

The transmitter has a wide operating temperature range, an IP66-rated corrosion-resistant metal enclosure, and an optional touchscreen display made of strengthened (IK08) glass.

The transmitter withstands commonly used cleaning chemicals, such as isopropanol and liquid H₂O₂ (30 %), and performs even in the harshest conditions.

The standard mounting options include mounting on a wall and on a DIN rail. With a retrofit mounting plate, the transmitter can be installed to replace an HMT330, DMT340, or MMT330 series transmitter. A pole mounting kit is also available as an accessory.

Technical data

Indigo-compatible probes

Measurement type	Probe models
Humidity and temperature	HMP1, HMP3, HMP4, HMP5, HMP7, HMP8, HMP9
Temperature	TMP1
Dew point	DMP1, DMP5, DMP6, DMP7, DMP8
Carbon dioxide	GMP251, GMP252
Vaporized hydrogen peroxide	HPP271, HPP272
Moisture in oil	MMP8

Other compatible devices

Device or series	Models
Moisture, Hydrogen and Temperature Transmitter MHT410	MHT410
Indigo80 Handheld Indicator	Indigo80

Transmitter options

Display	<ul style="list-style-type: none"> Capacitive touchscreen display No display (indicator LED)¹⁾
Powering	Protective extra-low voltage (11–35 V DC, 24 V AC ± 20 % 50/60 Hz)

1) Recommended when the transmitter is exposed to direct UV light, and for outdoor installations and high-humidity environments.

Mechanical specifications

Housing classification	IK08, DIN EN ISO 11997-1: Cycle B (VDA 621-415)
Housing material	AlSi10Mg (DIN 1725)
Display window material	Strengthened glass (IK08)
Weight	1.5 kg (3.3 lb)
Dimensions (H × W × D)	142 × 182 × 67 mm (5.63 × 7.17 × 2.64 in)

Cable diameters for cable glands

M20×1.5 glands	5.0–9.0 mm (0.20–0.35 in)
M20×1.5 glands with split bushing	7 mm (0.28 in)
M16×1.5 glands	2.0–6.0 mm (0.08–0.24 in)

Operating environment

Operating environment	Outdoor use
Use in wet location	Yes
Operating humidity	0–100 %RH
Maximum operating altitude	4000 m (approx. 13 100 ft)
IP rating	IP66 ¹⁾
UL 50E rating	Type 4

Operating temperature

With display	–20 ... +60 °C (–4 ... +140 °F)
Without display	–40 ... +60 °C (–40 ... +140 °F)

Storage temperature

With display	–30 ... +60 °C (–22 ... +140 °F)
Without display	–40 ... +60 °C (–40 ... +140 °F)

1) Evaluated by Eurofins, not by UL.

Powering

Operating power	
Protective extra-low voltage (PELV)	11–35 V DC, 24 V AC ±20 % 50/60 Hz, max. current 2 A (power supply is galvanically isolated) ¹⁾
	Fuse size for power supply: 3 A
	Isolation voltage: 500 V AC, 1000 V DC
PELV power cable temp. rating	≥ +80 °C (+176 °F)

Typical current consumption at +20 °C (+68 °F) (U_{in} 24 V DC)²⁾

Base consumption (no display, analog outputs, or communication)	50 mA
With display	+ 60 mA
With voltage analog output	< 2 mA per channel
With current analog output	+ 21 mA per channel
With Ethernet cable connected	+ 15 mA

1) The DNV type approval is valid in operating voltage range 15–35 V DC.

2) For the current consumption of the connected measurement device, see the device's documentation, available at docs.vaisala.com.

Inputs and outputs

Transmitter service port connection	<ul style="list-style-type: none"> Connection to Insight software with USB2 and cable 262195SP or with cable 219690¹⁾ Connection to Indigo80 with cable 262195SP
-------------------------------------	---

Analog outputs

Number of analog outputs	2
Isolation	Isolated from power supply
Selectable voltage output types	0–1 V, 0–5 V, 0–10 V, scalable
Selectable current output types	4–20 mA, 0–20 mA, scalable
Max. wire size	2.5 mm ² (14 AWG)
Accuracy of analog outputs at +20 °C (+68 °F)	±0.05 % full scale
Temperature dependence	±0.005 % / °C full scale

External loads:

Current outputs	R _L < 500 Ω
0–1 V output	R _L > 2 kΩ
0–5 V and 0–10 V outputs	R _L > 10 kΩ

Ethernet interface

Supported standards	10BASE-T, 100BASE-TX
Connector	8P8C (RJ45)
Supported protocols	Modbus TCP/IP (port 502), HTTPS (port 8443)
Vaisala cloud connectivity ²⁾	Requires outbound TCP port 443 and UDP port 123

1) Vaisala Insight PC Software for Windows® available at vaisala.com/insight.

2) Available only for transmitters ordered with software configuration for Vaisala cloud connectivity.

User interfaces

User interfaces	Web interface, optional touchscreen display, optional Vaisala cloud connectivity for remote monitoring ¹⁾
Supported languages	English, Chinese (simplified), Chinese (traditional), French, German, Japanese, Spanish
Optional display	5" capacitive touchscreen
Integrated data logging capabilities	Non-volatile memory, at least 10 years' storage with 24 h interval logging

¹⁾ Available only for transmitters ordered with software configuration for Vaisala cloud connectivity.

Compliance

EU directives and regulations	EMC Directive (2014/30/EU) RoHS Directive (2011/65/EU) as amended by 2015/863
Electromagnetic compatibility (EMC)	IEC/EN 61326-1, industrial environment CISPR 32 / EN 55032, Class B
Electrical safety	IEC/EN 61010-1
Type approvals	DNV GL certificate no. TAA000032M EU RO Mutual Recognition certificate no. MRA000004F
Compliance marks	CE, China RoHS, FCC, RCM, UKCA
Listing marks	UL Listed (USA and Canada)
FCC compliance	FCC Part 15, Class B

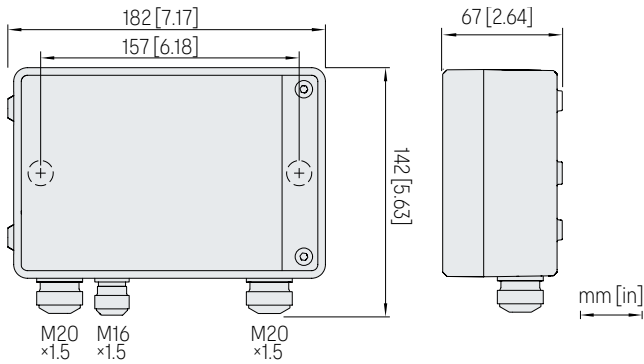

Indigo510 dimensions and lead-through sizes

Spare parts

Cable gland, M20×1.5, 5.0–9.0 mm (0.20–0.35 in)	ASM213670SP
Cable gland with split bushing, M20×1.5 ¹⁾	262632SP
Cable gland, M16×1.5, 2.0–6.0 mm (0.08–0.24 in)	ASM213671SP
Conduit fitting, M20×1.5 for NPT1/2" conduit	214780SP

¹⁾ With 7-mm (0.28 in) hole for cable and 14-mm (0.55 in) hole for 8P8C (RJ45) connector to pass through.

Accessories

Retrofit mounting plate	DRW252186SP
Installation kit for pole or pipeline	215108
Installation kit with weather shield	215109
Indigo500 spatter guard	ASM214526
M12 - M8 service cable 1.5 m (4.9 ft), for connecting to Indigo80	262195SP
Vaisala Indigo USB adapter and M12 - M8 service cable, for connecting to Insight software	USB2 and 262195SP
M8 - USB service cable, for connecting to Insight software	219690

Probe connection cables

Probe connection cable, 0.3 m (approx. 12 in), open end ¹⁾	CBL210896-03MSP
Probe connection cable, 1 m (approx. 3 ft 3 in), open end ¹⁾	CBL210896-1MSP
Probe connection cable, 3 m (approx. 9 ft 10 in), open end ¹⁾	CBL210896-3MSP
Probe connection cable, 5 m (approx. 16 ft 5 in), open end ¹⁾	CBL210896-5MSP
Probe connection cable, 10 m (approx. 32 ft 10 in), open end ¹⁾	CBL210896-10MSP

¹⁾ The usable length outside of the transmitter enclosure is approx. 0.1 m (4 in) shorter than the total length of the cable.

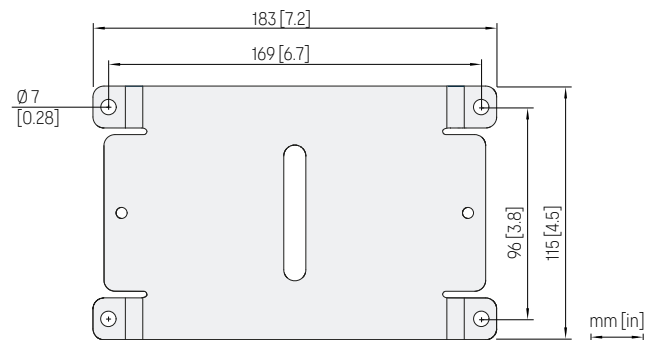

Indigo500 retrofit mounting plate dimensions

Indigo520 Transmitter For Vaisala Indigo-compatible probes



Features

- Supports 2 detachable measurement devices simultaneously
- Data logging of all measurement parameters
- IP66 rated metal enclosure
- 4 configurable galvanically isolated analog outputs
- 2-wire current loop analog input
- 2 relays
- Ethernet connection with web interface and optional Vaisala cloud connectivity for remote monitoring
- Displays measurements on the spot and transmits them to automation systems through analog signals, relays, or Modbus TCP/IP protocol

Vaisala Indigo520 Transmitter is an industrial-grade, robust transmitter that accommodates 1 or 2 Vaisala Indigo-compatible probes for humidity, temperature, dew point, carbon dioxide, hydrogen peroxide, and moisture in oil measurements. The transmitter can measure barometric pressure with an additional module.

Options

- Multiple powering options: Power over Ethernet, protective extra-low voltage, and AC (mains) power
- Available with Vaisala BAROCAP® barometric pressure sensor known for its high accuracy and excellent long-term stability
- Optional non-display model with LED indicator

Variety of probe options

The Indigo500 series transmitters are the most versatile option for use with Indigo-compatible probes.

- HMP series humidity and temperature probes
- DMP series dew point probes
- GMP250 series carbon dioxide probes

- HPP270 series vaporized hydrogen peroxide probes
- MMP8 moisture in oil probe

The probes are interchangeable, self-contained measurement instruments that are easily detachable from the transmitter for calibration and maintenance. The probes are connected using a cable that can be extended with a standard instrumentation cable to allow up to 30 m (98 ft) distance between the transmitter and the probe.

The Indigo500 series transmitters can be connected to the MHT410 transmitter for display of measurement data and automation system connectivity. Through the transmitter service port, the Indigo500 series transmitters can also be connected to the free Vaisala Insight PC Software or Indigo80 Handheld Indicator.

The Indigo520 transmitter can be connected to Polaris™ PR53 Process Refractometers for measuring liquid concentrations.

For more information on the Indigo product family, see vaisala.com/indigo.

Analog and digital interfaces

The Indigo520 transmitter has 4 analog channels that can be configured to mA or voltage type, and 2 configurable relays. Any of the output parameters from the connected probes can be assigned to control the analog channels and relays.

The digital output protocol is Modbus TCP/IP over Ethernet. The Ethernet connection also provides a web interface and cybersecurity that meets modern standards. The Indigo500 series transmitters can be ordered with a possibility for Vaisala cloud connection for remote monitoring.

Technical data

Indigo-compatible probes

Measurement type	Probe models
Humidity and temperature	HMP1, HMP3, HMP4, HMP5, HMP7, HMP8, HMP9
Temperature	TMP1
Dew point	DMP1, DMP5, DMP6, DMP7, DMP8
Carbon dioxide	GMP251, GMP252
Vaporized hydrogen peroxide	HPP271, HPP272
Moisture in oil	MMP8

Other compatible devices

Device or series	Models
Moisture, Hydrogen and Temperature Transmitter MHT410	MHT410
Polaris™ Process Refractometers ¹⁾	PR53AC, PR53AP, PR53GC, PR53GP, PR53M, PR53SD, PR53W
Indigo80 Handheld Indicator	Indigo80
MGP241 Multigas Probe	MGP241
MGP260 Series Multigas Probes	MGP261, MGP262
Differential Pressure Transmitters ²⁾	PDT101, PDT102

¹⁾ Compatible with transmitters ordered with software configuration "L" for process refractometers.
²⁾ PDT101 and PDT102 can be used through analog input.

Transmitter options

Display	<ul style="list-style-type: none"> Capacitive touchscreen display No display (indicator LED) ¹⁾
Powering	<ul style="list-style-type: none"> Protective extra-low voltage (15–35 V DC, 24 V AC ± 20%) AC (mains) power (100–240 V AC 50/60 Hz) Power over Ethernet (no analog outputs, analog input, or relays)

¹⁾ Recommended when the transmitter is exposed to direct UV light, and for outdoor installations and high-humidity environments.

Measurement performance

Barometric pressure (optional module)	
Pressure range	500–1100 hPa
Class A:	
Linearity	±0.05 hPa
Hysteresis	±0.03 hPa
Repeatability	±0.03 hPa
Calibration uncertainty	±0.07 hPa
Accuracy at +20 °C / +68 °F	±0.10 hPa
Temperature dependence	±0.1 hPa
Total accuracy (-40 ... +60 °C / -40 ... +140 °F)	±0.15 hPa
Long-term stability/year	±0.1 hPa
Response time (100 % response):	
One sensor	2 s
Pressure units	hPa, mbar, kPa, Pa, inHg, mmH2O, mmHg, torr, psia

Mechanical specifications

Housing classification	IK08, DIN EN ISO 11997-1: Cycle B (VDA 621-415)
Housing material	AlSi10Mg (DIN 1725)
Display window material	Strengthened glass (IK08)
Weight	1.5 kg (3.3 lb)
Dimensions (H × W × D)	142 × 182 × 67 mm (5.63 × 7.17 × 2.64 in)

Cable diameters for cable glands

M20×1.5 glands	5.0–9.0 mm (0.20–0.35 in)
M20×1.5 glands with split bushing	7 mm (0.28 in)
M16×1.5 glands	2.0–6.0 mm (0.08–0.24 in)

Operating environment

Operating environment	Outdoor use
Use in wet location	Yes
Operating humidity	0–100 %RH
Maximum operating altitude, AC (mains) power	3000 m (approx. 9800 ft)
Maximum operating altitude, protective extra-low voltage (PELV) and Power over Ethernet (PoE)	4000 m (approx. 13 100 ft)
IP rating	IP66 ¹⁾
UL 50E rating	Type 4

Operating temperature

With display	-20 ... +55 °C (-4 ... +131 °F)
Without display	-40 ... +60 °C (-40 ... +140 °F)
Without display with barometer module	-40 ... +55 °C (-40 ... +131 °F)

Storage temperature

With display	-30 ... +60 °C (-22 ... +140 °F)
Without display	-40 ... +60 °C (-40 ... +140 °F)

¹⁾ Evaluated by Eurofins, not by UL.

Powering

Operating power ¹⁾

Protective extra-low voltage (PELV) version 15–35 V DC, 24 V AC $\pm 20\%$ 50/60 Hz, max. current 2 A (power supply is galvanically isolated)

Fuse size for power supply: 3 A

Isolation voltage: 500 V AC, 1000 V DC

PELV power cable temp. rating $\geq +80\text{ }^\circ\text{C}$ (+176 $^\circ\text{F}$)

AC (mains) power version 100–240 V AC 50/60 Hz, max. current 1 A (power supply is galvanically isolated)

Fuse size for power supply: 10 A

Isolation voltage: 1500 V AC

AC (mains) power cable length 2.5 m (approx. 8 ft 2 in)

Power over Ethernet version Power over Ethernet (PoE) IEEE 802.3at Type 2 Class 4
Max. current 600 mA, max. power consumption 25.5 W
Isolation voltage: 500 V AC, 1000 V DC

Typical current consumption at +20 $^\circ\text{C}$ (+68 $^\circ\text{F}$) (U_{in} 24 V DC) ²⁾

Base consumption (no display, analog outputs, or communication) 50 mA

With display + 60 mA

With voltage analog output < 2 mA per channel

With current analog output + 21 mA per channel

With relays + 9 mA per relay

With Ethernet cable connected + 15 mA

With barometer module + 5 mA

¹⁾ The power supply option is selected when ordering the transmitter.

²⁾ For the current consumption of the connected measurement device, see the device's documentation, available at docs.vaisala.com.

User interfaces

User interfaces Web interface, optional touchscreen display, optional Vaisala cloud connectivity for remote monitoring ¹⁾

Supported languages English, Chinese (simplified), Chinese (traditional), French, German, Japanese, Spanish

Optional display 5" capacitive touchscreen

Integrated data logging capabilities Non-volatile memory, at least 10 years' storage with 24 h interval logging

Inputs and outputs

Transmitter service port connection

- Connection to Insight software with USB2 and cable 262195SP or with cable 219690 ¹⁾
- Connection to Indigo80 with cable 262195SP

Analog input ²⁾

Available ranges 4–20 mA

Resolution 6 μA

Display resolution 0.01 mA

Accuracy $\pm 0.05\text{ mA}$

Input impedances 200 Ω

Isolation Isolated from power supply

Overload protection 40 mA max. (reverse polarity protected)

Analog outputs ²⁾

Number of analog outputs 4

Isolation Isolated from power supply

Selectable voltage output types 0–1 V, 0–5 V, 0–10 V, scalable

Selectable current output types 4–20 mA, 0–20 mA, scalable

Max. wire size 2.5 mm² (14 AWG)

Accuracy of analog outputs at +20 $^\circ\text{C}$ (+68 $^\circ\text{F}$) $\pm 0.05\%$ full scale

Temperature dependence $\pm 0.005\%$ / $^\circ\text{C}$ full scale

External loads:

Current outputs $R_L < 500\ \Omega$

0–1 V output $R_L > 2\ \text{k}\Omega$

0–5 V and 0–10 V outputs $R_L > 10\ \text{k}\Omega$

Relay outputs ²⁾

Number and type of relays 2 pcs, SPDT

Max. switching power, current, voltage 30 W, 1 A, 40 V DC / 28 V AC

Max. wire size in PELV version 2.5 mm² (14 AWG)

Max. wire size in AC (mains) version 1.5 mm² (16 AWG)

Ethernet interface

Supported standards 10BASE-T, 100BASE-TX

Connector 8P8C (RJ45)

Supported protocols Modbus TCP/IP (port 502), HTTPS (port 8443)

Vaisala cloud connectivity ³⁾ Requires outbound TCP port 443 and UDP port 123

¹⁾ Vaisala Insight PC Software for Windows® available at vaisala.com/insight.

²⁾ Not available in transmitters that are powered with Power over Ethernet (PoE).

³⁾ Available only for transmitters ordered with software configuration for Vaisala cloud connectivity.

Compliance

EU directives and regulations EMC Directive (2014/30/EU)
Low Voltage Directive (2014/35/EU)
RoHS Directive (2011/65/EU) as amended by 2015/863

Electromagnetic compatibility (EMC) IEC/EN 61326-1, industrial environment
CISPR 32 / EN 55032, Class B

Electrical safety IEC/EN 61010-1

Type approvals DNV GL certificate no. TAA000032M
EU RO Mutual Recognition certificate no. MRA000004F

Compliance marks CE, China RoHS, FCC, RCM, UKCA

Listing marks UL Listed (USA and Canada)

FCC compliance FCC Part 15, Class B



Spare parts

Cable gland, M20×1.5, 5.0–9.0 mm (0.20–0.35 in)	ASM213670SP
Cable gland, M20×1.5, 10.0–14.0 mm (0.39–0.55 in)	ASM215414
Cable gland with split bushing, M20×1.5 ¹⁾	262632SP
Cable gland, M16×1.5, 2.0–6.0 mm (0.08–0.24 in)	ASM213671SP
Conduit fitting, M20×1.5 for NPT1/2" conduit	214780SP
Sintered filter (for barometer module)	DRW010335SP

¹⁾ With 7-mm (0.28 in) hole for cable and 14-mm (0.55 in) hole for 8P8C (RJ45) connector to pass through.

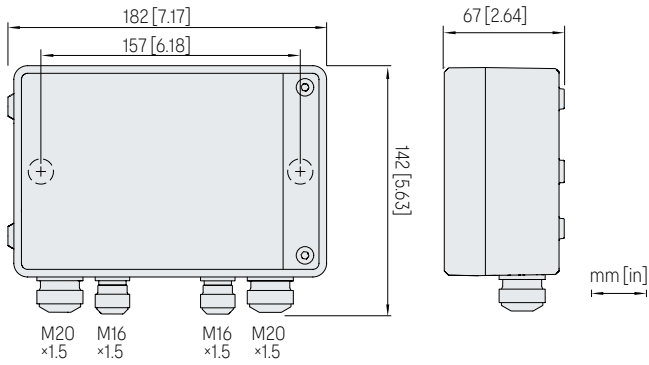

Indigo520 dimensions and lead-through sizes

Accessories

Retrofit mounting plate	DRW252186SP
Installation kit for pole or pipeline	215108
Installation kit with weather shield	215109
Indigo500 spatter guard	ASM214526
M12 - M8 service cable 1.5 m (4.9 ft), for connecting to Indigo80	262195SP
Vaisala Indigo USB adapter and M12 - M8 service cable, for connecting to Insight software	USB2 and 262195SP
M8 - USB service cable, for connecting to Insight software	219690

Probe connection cables

Probe connection cable, 0.3 m (approx. 12 in), open end ¹⁾	CBL210896-03MSP
Probe connection cable, 1 m (approx. 3 ft 3 in), open end ¹⁾	CBL210896-1MSP
Probe connection cable, 3 m (approx. 9 ft 10 in), open end ¹⁾	CBL210896-3MSP
Probe connection cable, 5 m (approx. 16 ft 5 in), open end ¹⁾	CBL210896-5MSP
Probe connection cable, 10 m (approx. 32 ft 10 in), open end ¹⁾	CBL210896-10MSP

¹⁾ The usable length outside of the transmitter enclosure is approx. 0.1 m (4 in) shorter than the total length of the cable.

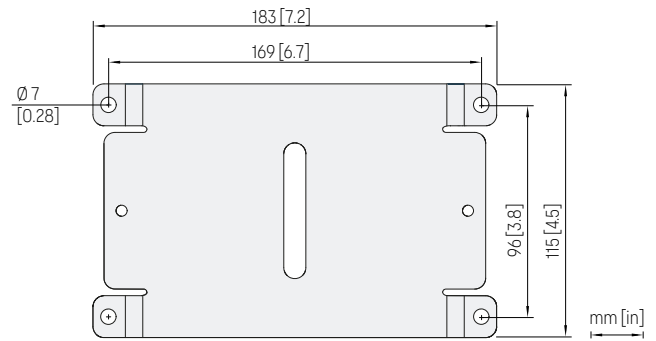

Indigo500 retrofit mounting plate dimensions



Features

- Accurate and reliable measurement with Vaisala HUMICAP® humidity sensor technology
- Interchangeable probe, easy field calibration
- Resistant to dust and most chemicals
- Enclosure IP65
- Traceable calibration certificate: 3 points for humidity, 1 point for temperature
- Suitable for cleanrooms and other demanding HVAC and light industrial applications

Vaisala HUMICAP® Humidity and Temperature Transmitters HMT120 and HMT130 are designed for humidity and temperature monitoring in cleanrooms and are also suitable for other demanding HVAC and light industrial applications.

Options

- Humidity parameter options: relative humidity, dew point/frost point, wet bulb temperature, enthalpy, absolute humidity, mixing ratio, vapor pressure, and saturation vapor pressure
- 2-wire loop-powered or 3-wire voltage output configurations
- Optional LCD display
- Wall-mounted transmitter with a fixed or remote probe
- Constant output probe available
- Can be mounted outdoors using a Vaisala installation kit and Vaisala Radiation Shield DTR504A

Performance

The HMT120 and HMT130 transmitters incorporate Vaisala HUMICAP® humidity sensor technology that measures relative humidity accurately and reliably. Vaisala HUMICAP® sensors are resistant to dust and most chemicals.

The HMT120 and HMT130 transmitter enclosure is optimized for use in cleanrooms. The smooth surface of the enclosure makes it easy to clean and the enclosure material is chosen to tolerate cleaning agents. Furthermore, cabling can be done through the back wall of the transmitter.

Interchangeable probe

The HMT120 and HMT130 transmitters use a fully interchangeable relative humidity probe. The probe can be easily removed and replaced with a new one without having to adjust the transmitter, which allows for easy and quick recalibration of the transmitter. The probe can be adjusted using one of Vaisala's handheld meters as a reference. Also available is a constant output probe with fixed RH and T output for convenient inspection of the monitoring system and signal transfer line.

Available options

The HMT120 and HMT130 transmitters are available as wall mounted with a fixed or remote probe. For high temperature applications or where space is limited, the remote probe is ideal. The optional LCD display shows the measurement values of the selected parameters in selected units. The parameters are displayed simultaneously on two separate rows on the display.

Technical data

Models

Model	Measured parameters	Probe options	Output
HMT120	RH + T	HMP110, HMP113	2 analog outputs, 4–20 mA (loop-powered)
HMT130	RH + T	HMP110, HMP113	2 analog outputs, 0–1 V, 0–5 V, 0–10 V, or user-defined between 0–10 V

Measurement performance

Relative humidity	
Measurement range	0–100 %RH
Accuracy 1) 2)	
At 0 ... +40 °C (+32 ... +104 °F)	±1.5 %RH (0–90 %RH) ±2.5 %RH (90–100 %RH)
With HMP110 probe: At –40 ... 0 °C and +40 ... +80 °C (–40 ... +32 °F and +104 ... +176 °F)	±3.0 %RH (0–90 %RH) ±4.0 %RH (90–100 %RH)
With HMP113 probe: At –40 ... 0 °C and +40 ... +60 °C (–40 ... +32 °F and +104 ... +140 °F)	
Factory calibration uncertainty at +20 °C (+68 °F)	±1.1 %RH (0–90 %RH) ±1.8 %RH (90–100 %RH)
Humidity sensor types	HUMICAP® 180R HUMICAP® 180V 3)
Stability	±2 %RH over 2 years
Stability in typical HVAC applications	±0.5 %RH per year
Temperature	
Measurement range	HMP110: –40 ... +80 °C (–40 ... +176 °F) HMP113: –40 ... +60 °C (–40 ... +140 °F)
Temperature sensor	Pt1000 RTD Class F0.1 IEC 60751
Accuracy over temperature range:	
HMP110:	
At +15 ... +25 °C (+59 ... +77 °F)	±0.1 °C (±0.18 °F)
At 0 ... +15 °C and +25 ... +40 °C (+32 ... +59 °F and +77 ... +104 °F)	±0.15 °C (±0.27 °F)
At –40 ... +0 °C and +40 ... +80 °C (–40 ... +32 °F and +104 ... +176 °F)	±0.4 °C (±0.72 °F)
HMP113:	
At 0 ... +40 °C (+32 ... +104 °F)	±0.2 °C (±0.36 °F)
At –40 ... 0 °C and +40 ... +60 °C (–40 ... +32 °F and +104 ... +140 °F)	±0.4 °C (±0.72 °F)
Other output parameters (optional)	
Dew point/frost point, wet bulb temperature, enthalpy, absolute humidity, mixing ratio, vapor pressure, saturation vapor pressure	

1) Including non-linearity, hysteresis, and repeatability.

2) With HUMICAP® 180V sensor, accuracy is specified only in operating temperature –20 ... +80 °C (–4 ... +176 °F).

3) Not available with HMP113.

Operating environment

IP rating (transmitter body)	IP65 1)
Operating temperature of transmitter body, no display	–40 ... +60 °C (–40 ... +140 °F)
Operating temperature of transmitter body with display	–20 ... +60 °C (–4 ... +140 °F)
Operating temperature, probe	HMP110: –40 ... +80 °C (–40 ... +176 °F) HMP113: –40 ... +60 °C (–40 ... +140 °F)
Storage temperature	–50 ... +70 °C (–58 ... +158 °F)

1) IP65 for the HMP110 probe only when using stainless steel sintered filter (HM46670SP) or PTFE sintered filter (item code DRW244938SP).

Inputs and outputs

HMT120 2-wire transmitter (loop-powered)	
Current output signals	4–20 mA
External loop voltage	10–30 V DC ($R_L = 0 \Omega$) 20–30 V DC ($R_L < 500 \Omega$)
HMT130 3-wire transmitter	
Voltage output signals	0–1 V, 0–5 V, 0–10 V or user-defined between 0–10 V
Min. output resistance	1 k Ω
Serial output	RS-485, non-isolated
Relay output	1 relay (max. 50 V DC, 200 mA)
Supply voltage	10–35 V DC 15–35 V DC (when output 0–10 V) 24 V AC (±20 %)
Current consumption at 24 V DC	8 mA, if relay closed 15 mA
Max. additional error caused by the analog outputs after calibration at +20 °C (+68 °F) ambient temperature	±0.1 % of FS output signal
Temperature dependence of the analog outputs	±0.005 % of FS output signal

Mechanical specifications

Weight	270 g (9.5 oz)
Probe connection cable lengths	3 m, 5 m, 10 m - up to 50 m (9.8 ft, 16 ft, 33 ft - up to 164 ft)
Display (optional)	128 × 64 resolution full graphics B&W display without backlight
Material	
Transmitter housing	PBT plastic
Display window	PC plastic
Probe body	HMP110: Stainless steel (AISI 316) HMP113: PC/ABS blend
Probe grid filter	HMP110: Chrome coated ABS plastic HMP113: PC (glass reinforced)
Connections	
Inputs and outputs	Screw terminals 0.5–1.5 mm ² (AWG 20–AWG 15)
Probe interface	4-pin M8 female panel connector

Compliance

EU directives and regulations	EMC, RoHS
Electromagnetic compatibility (EMC)	EN 61326-1, basic electromagnetic environment CISPR 32 / EN 55032, Class B
Compliance marks	CE, RCM

Spare parts and accessories

Probes ¹⁾

Humidity and temperature probe	HMP110
Constant output probe	HMP110REF
Humidity and temperature probe	HMP113

Sensors

HMP110 and HMP113 probes:

Standard humidity sensor	HUMICAP180R
Catalytic humidity sensor for H ₂ O ₂	HUMICAP180V ²⁾

Sensor protection

HMP110 probe:

Plastic grid filter	DRW010522SP
Plastic grid with membrane filter	DRW010525SP
Stainless steel sintered filter	HM46670SP
PTFE membrane filter with stainless steel grid	ASM212652SP
PTFE sintered filter	DRW244938SP

HMP113 probe:

Plastic grid filter	DRW240185SP
Plastic grid with membrane filter	ASM210856SP
Stainless steel sintered filter	HM47280SP
Porous PTFE filter	219452SP

Probe installation

HMP110 and HMP113 (remote probe models):

Probe mounting clamp, 1 pc	225501
Probe mounting clamps, 10 pcs	226067
Probe mounting flange	226061
Probe holder, 5 pcs	ASM213382SP

Probe connection cables ³⁾

Probe connection cable 3 m (9.8 ft)	HMT120Z300
Probe connection cable 5 m (16 ft)	HMT120Z500
Probe connection cable 10 m (33 ft)	HMT120Z1000
Probe connection cable 20 m (66 ft)	HMT120Z2000
Probe connection cable 5 m (16 ft), plenum-rated	HMT120Z500CMP
Probe connection cable 10 m (33 ft), plenum-rated	HMT120Z1000CMP
Probe connection cable 20 m (66 ft), plenum-rated	HMT120Z2000CMP

Other cables

HM70 connection cable	211339
USB serial interface cable	219685

Transmitter protection and installation

Radiation shield ³⁾	DTR504A
Rain shield with installation kit	215109
Duct installation kit ³⁾	215619

1) See the separate HMP110 and HMP113 order forms.
2) Not available with HMP113.
3) For use with remote probe models.

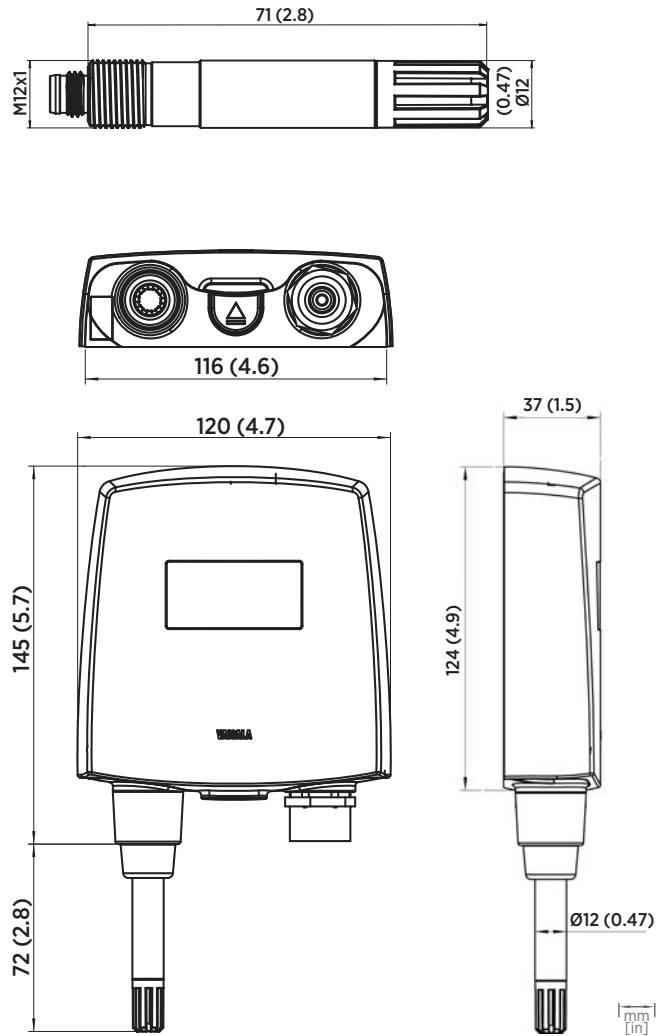

Dimensions of HMP110 remote probe (top image) and HMT120 and HMT130 transmitters



Features

- Platinum RTD temperature sensor for outstanding measurement stability and accuracy
- Interchangeable probe, easy field calibration
- Resistant to dust and most chemicals
- Enclosure IP65
- Traceable calibration certificate: 1 point for temperature
- Suitable for cleanrooms and other demanding HVAC and light industrial applications

Vaisala Temperature Transmitters TMT120 and TMT130 are designed for temperature monitoring in cleanrooms and are also suitable for other demanding HVAC and light industrial applications.

Options

- 2-wire loop-powered or 3-wire voltage output configurations
- Extended temperature range with the TMP115 wide-range temperature probe
- Optional LCD display
- Wall-mounted transmitter with a fixed or remote probe
- Can be mounted outdoors using a Vaisala installation kit and Vaisala Radiation Shield DTR504A

Performance

The TMT120 and TMT130 transmitters incorporate platinum RTD temperature sensor technology for outstanding measurement stability and accuracy.

The TMT120 and TMT130 transmitter enclosure is optimized for use in cleanrooms. The smooth surface of the enclosure makes it easy to clean and the enclosure material is chosen to tolerate cleaning agents. Furthermore, cabling can be done through the back wall of the transmitter.

Interchangeable probe

The TMT120 and TMT130 transmitters use a fully interchangeable temperature probe. The probe can be easily removed and replaced with a new one without having to adjust the transmitter, which allows for easy and quick recalibration of the transmitter. The probe can be adjusted using one of Vaisala's handheld meters as a reference.

Available options

The TMT120 and TMT130 transmitters are available as wall mounted with a fixed or remote probe. For high temperature applications or where space is limited, the remote probe is ideal.

For an extended temperature range, the transmitter can be optionally ordered with TMP115, a wide-range temperature probe, which includes a 3-m (9.8 ft) sensor cable. The length includes the probe body and sensor tip.

The optional LCD display shows the measurement values in selected units.

Technical data

Models

Model	Measured parameters	Probe options	Output
TMT120	T	HMP110T, TMP115 ¹⁾	1 analog output, 4–20 mA (loop-powered)
TMT130	T	HMP110T, TMP115 ¹⁾	1 analog output, 0–1 V, 0–5 V, 0–10 V, or user-defined between 0–10 V

¹⁾ TMP115 with a 3 m (9.8 ft) cable. Length includes the TMP115 probe body and sensor tip.

Measurement performance

Temperature	
Measurement range	HMP110T: –40 ... +80 °C (–40 ... +176 °F) TMP115: –196 ... +150 °C (–320 ... +302 °F)
Temperature sensor	Pt1000 RTD Class F0.1 IEC 60751
Accuracy over temperature range:	
HMP110T:	
At +15 ... +25 °C (+59 ... +77 °F)	±0.1 °C (±0.18 °F)
At 0 ... +15 °C and +25 ... +40 °C (+32 ... +59 °F and +77 ... +104 °F)	±0.15 °C (±0.27 °F)
At –40 ... +0 °C and +40 ... +80 °C (–40 ... +32 °F and +104 ... +176 °F)	±0.4 °C (±0.72 °F)
TMP115:	
at –196 ... –90 °C (–320 ... –130 °F)	±2.5 °C (±4.5 °F)
at –90 ... –30 °C (–130 ... –22 °F)	±0.75 °C (±1.35 °F)
at –30 ... 0 °C (–22 ... +32 °F)	±0.5 °C (±0.9 °F)
at 0 ... +50 °C (+32 ... +122 °F)	±0.25 °C (±0.45 °F)
at +50 ... +90 °C (+122 ... +194 °F)	±0.75 °C (±1.35 °F)
at +90 ... +150 °C (+194 ... +302 °F)	±2.5 °C (±4.5 °F)

Operating environment

IP rating (transmitter body)	IP65 ¹⁾
Operating temperature of transmitter body, no display	–40 ... +60 °C (–40 ... +140 °F)
Operating temperature of transmitter body with display	–20 ... +60 °C (–4 ... +140 °F)
Operating temperature, probe	HMP110T: –40 ... +80 °C (–40 ... +176 °F) TMP115, sensor tip: –196 ... +150 °C (–320 ... +302 °F) TMP115, probe body: –40 ... +60 °C (–40 ... +140 °F)
Storage temperature	–50 ... +70 °C (–58 ... +158 °F)

¹⁾ IP65 for the HMP110T probe only when using stainless steel sintered filter (HM46670SP) or PTFE sintered filter (item code DRW244938SP).

Inputs and outputs

TMT120 2-wire transmitter (loop-powered)	
Current output signals	4–20 mA
External loop voltage	10–30 V DC ($R_L = 0 \Omega$) 20–30 V DC ($R_L < 500 \Omega$)
TMT130 3-wire transmitter	
Voltage output signals	0–1 V, 0–5 V, 0–10 V or user-defined between 0–10 V
Min. output resistance	1 k Ω
Serial output	RS-485, non-isolated
Relay output	1 relay (max. 50 V DC, 200 mA)
Supply voltage	10–35 V DC 15–35 V DC (when output 0–10 V) 24 V AC (±20 %)
Current consumption at 24 V DC	8 mA, if relay closed 15 mA
Max. additional error caused by the analog outputs after calibration at +20 °C (+68 °F) ambient temperature	±0.1 % of FS output signal
Temperature dependence of the analog outputs	±0.005 % of FS output signal

Mechanical specifications

Weight	270 g (9.5 oz)
Probe connection cable lengths	3 m, 5 m, 10 m - up to 50 m (9.8 ft, 16 ft, 33 ft - up to 164 ft)
Display (optional)	128 × 64 resolution full graphics B&W display without backlight
Material	
Transmitter housing	PBT plastic
Display window	PC plastic
HMP110T probe body	Stainless steel (AISI 316)
HMP110T probe grid filter	Chrome coated ABS plastic
TMP115 probe body	PC/ABS blend
TMP115 probe cable	FEP
TMP115 sensor tip	Stainless steel (AISI 316)
Connections	
Inputs and outputs	Screw terminals 0.5–1.5 mm ² (AWG 20–AWG 15)
Probe interface	4-pin M8 female panel connector

Compliance

EU directives and regulations	EMC, RoHS
Electromagnetic compatibility (EMC)	EN 61326-1, basic electromagnetic environment CISPR 32 / EN 55032, Class B
Compliance marks	CE, RCM

Spare parts and accessories

Probes ¹⁾

Temperature-only probe	HMP110T
Wide-range temperature probe	TMP115 with a 3 m (9.8 ft) cable ²⁾

Sensor protection

HMP110T probe:

Plastic grid filter	DRW010522SP
Plastic grid with membrane filter	DRW010525SP
Stainless steel sintered filter	HM46670SP
PTFE membrane filter with stainless steel grid	ASM212652SP
PTFE sintered filter	DRW244938SP

Probe installation

Remote probe models with HMP110T:

Probe mounting clamp, 1 pc	225501
Probe mounting clamps, 10 pcs	226067
Probe mounting flange	226061
Probe holder, 5 pcs	ASM213382SP

Fixed probe models with TMP115:

Probe nut, 5 pcs	DRW257207SP
Thermal dampener block	236310SP

Probe connection cables ³⁾

Probe connection cable 3 m (9.8 ft)	HMT120Z300
Probe connection cable 5 m (16 ft)	HMT120Z500
Probe connection cable 10 m (33 ft)	HMT120Z1000
Probe connection cable 20 m (66 ft)	HMT120Z2000

Other cables

HM70 connection cable	211339
USB serial interface cable	219685

Transmitter protection and installation

Radiation shield ³⁾	DTR504A
Rain shield with installation kit	215109
Duct installation kit ³⁾	215619

1) See the separate HMP110 and TMP115 order forms.
 2) Length includes the TMP115 probe body and sensor tip.
 3) For use with remote probe models.

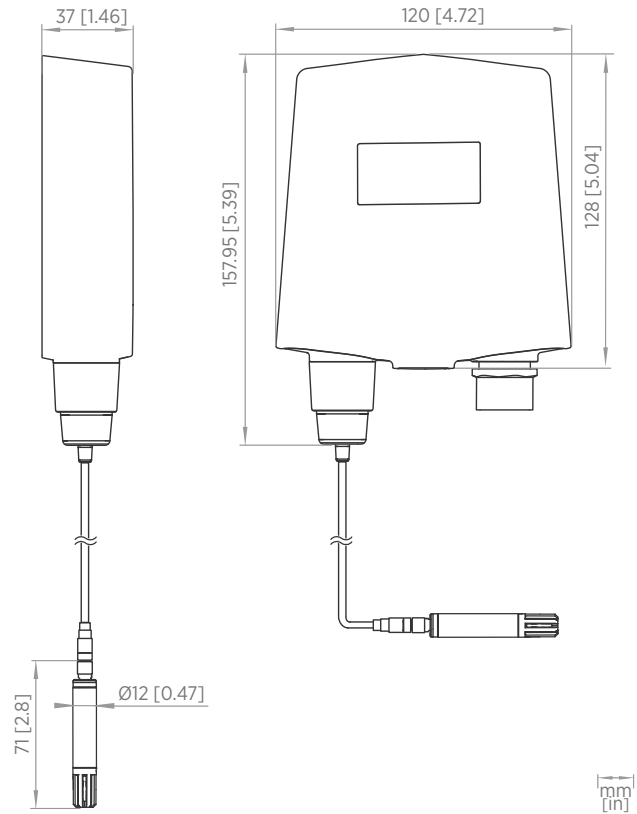

Dimensions of TMT120 and TMT130 transmitter, remote probe model with HMP110T probe

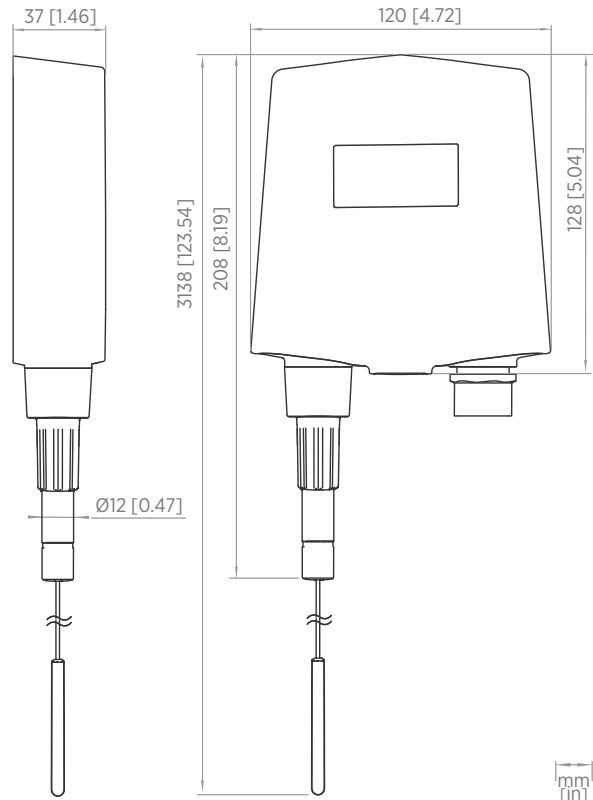

Dimensions of TMT120 and TMT130 transmitter, fixed probe model with a TMP115 probe

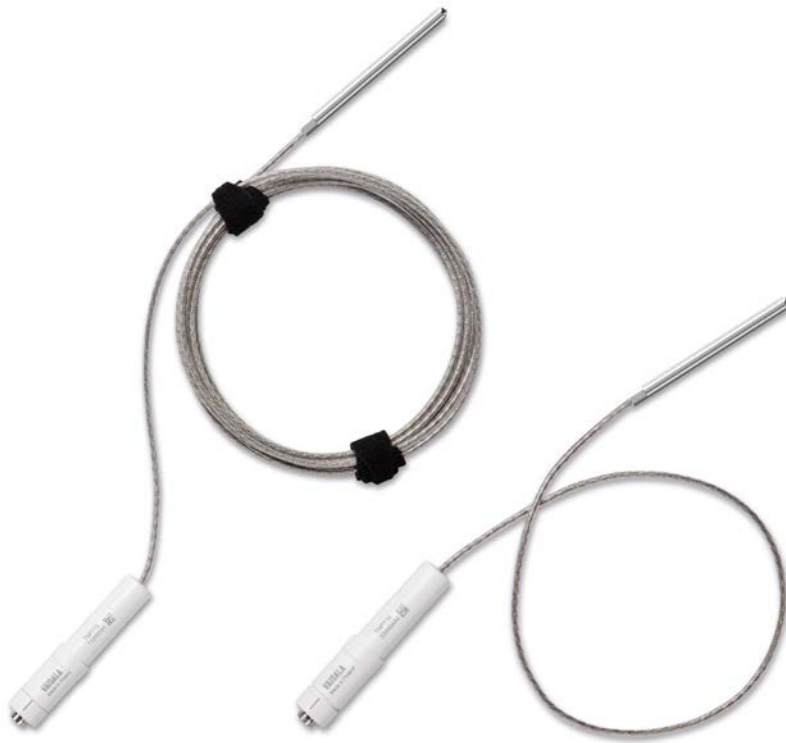

Features

- Measurement range
–196 ... +150 °C (–320 ... +302 °F)
- Platinum RTD temperature sensor for outstanding measurement stability
- Available as 0.5 m (1 ft 7.7 in) and 3 m (9.8 ft) long versions
- Can be used in Vaisala RFL100, CWL100, and VDL200 data loggers, and TMT120 and TMT130 transmitters
- Compatible with Vaisala Insight PC software and Vaisala Indigo80 Handheld Indicator
- Traceable calibration certificate

Wide-Range Temperature Probe TMP115 is ideal for use in temperature-controlled chambers, cryogenic applications, incubators, LN₂ tanks, and blood/tissue banks. TMP115 uses a platinum RTD temperature sensor for outstanding measurement stability.

Flexible connectivity

TMP115 can be used in Vaisala RFL100, CWL100, and VDL200 data loggers, and TMT120 and TMT130 transmitters. It can also be used as a standalone digital Modbus RTU transmitter over an RS-485 serial bus. The probe is available in two lengths: 0.5 m (1 ft 7.7 in) and 3 m (9.8 ft). The length includes probe body and sensor tip.

The operating temperature range of the probe body is –40 ... +60 °C (–40 ... +140 °F). It is usually best to leave the probe body outside the measured environment, and just insert the probe tip and some cable.

Low power consumption

TMP115 is suitable for battery-powered applications due to its very low power consumption. It also has an extremely fast start-up time.

Features for cold storage applications

Some cold storage applications may require slowing down the naturally fast response time of the probe. You can easily accomplish this by adding more thermal mass to the sensor tip. The thermal dampener block accessory (item code 236310SP) is designed for this purpose. The damping effect of the block is equivalent to that of 40 ml of glycol.

The 4.8 mm (0.19 in) diameter sensor tip withstands immersion in glycol and liquid nitrogen.

Flat cables are available as accessories for the compatible data loggers in case door seal insertion to chambers and freezers is required.

Variety of calibration options

A quick field calibration can easily be carried out using a handheld device, for example, Vaisala Indigo80 Handheld Indicator or Vaisala Handheld Meter HM40. Alternatively, the probe can be calibrated using a PC with Vaisala Insight PC software and a compatible USB connection cable, or sent to Vaisala for calibration. Vaisala Service Centers offer both ISO 9001 and ISO 17025 calibrations.

Technical data

Measurement performance

Temperature

Measurement range -196 ... +150 °C (-320 ... +302 °F)¹⁾

Accuracy over temperature range²⁾

at -196 ... -90 °C (-320 ... -130 °F) ±2.5 °C (±4.5 °F)

at -90 ... -30 °C (-130 ... -22 °F) ±0.75 °C (±1.35 °F)

at -30 ... 0 °C (-22 ... +32 °F) ±0.5 °C (±0.9 °F)

at 0 ... +50 °C (+32 ... +122 °F) ±0.25 °C (±0.45 °F)

at +50 ... +90 °C (+122 ... +194 °F) ±0.75 °C (±1.35 °F)

at +90 ... +150 °C (+194 ... +302 °F) ±2.5 °C (±4.5 °F)

Temperature sensor Pt100 RTD Class A IEC 751

Typical factory calibration uncertainty

at -90 °C (-130 °F) ±0.13 °C (±0.234 °F)

at -45 °C (-49 °F) ±0.07 °C (±0.149 °F)

at 0 °C (32 °F) and warmer ±0.06 °C (±0.128 °F)

1) The measurement range of TMP115 probes manufactured with firmware version older than 2.6.3 is -196 ... +90 °C (-320 ... +194 °F).

2) Includes non-linearity, hysteresis, and repeatability.

Operating environment

Operating temperature of sensor tip -196 ... +150 °C (-320 ... +302 °F)

Operating temperature of probe body¹⁾ -40 ... +60 °C (-40 ... +140 °F)

IP rating of sensor tip IP67

IP rating of probe body IP65

1) Heat conduction along the probe cable may affect the temperature of the probe body. Model with 3 m (9.8 ft) probe cable is recommended for continuous measurement of very hot and cold temperatures.

Compliance

EU directives and regulations RoHS Directive (2011/65/EU) as amended by 2015/863

Electromagnetic compatibility (EMC) EN 61326-1, industrial environment

Compliance marks CE, RCM

Inputs and outputs

Operating voltage 5–28 V DC

Start-up time 1 s

Digital output RS-485 2-wire half duplex, supports Modbus RTU

Output parameters Temperature (°C)

Mechanical specifications

Cable connector 4-pin male M8 (IEC 60947-5-2)

Materials

Probe body PC/ABS blend

Cable FEP

Sensor tip Stainless steel (AISI 316)

Dimensions

Probe length including cable and sensor tip 0.5 m (1 ft 7.7 in) or 3 m (9.8 ft)

Probe body diameter 14 mm (0.55 in)

Sensor tip length 70 mm (2.76 in)

Sensor tip diameter 4.76 mm (0.19 in)

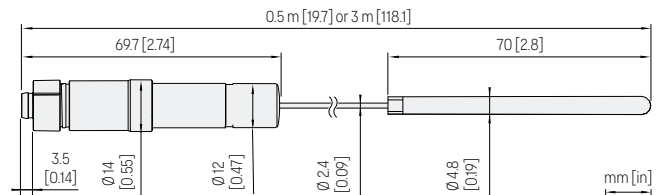

TMP115 dimensions

Accessories

Thermal dampener block for 3/16" probes (4.8 mm) 236310SP

Probe holder (5 pcs) ASM213382SP

Probe nut (5 pcs) for connection to VDL200 data logger, TMT120/130 transmitter, and HM40 handheld meter DRW257207SP

USB cable for PC connection 219690

Connection cable for Indigo80 handheld indicator 262195SP

Connection cable for MI70 indicator 219980SP

Connection cable for HM40 handheld meter HMT120Z300

HMP63 Humidity and Temperature Probe



Features

- Fast thermal response time
- Low power consumption
- Start-up time < 2 s
- Measurement range: 0–100 %RH; –40 ... +60 °C (–40 ... +140 °F)
- Cable detachable with standard M8 connector
- IP54-rated plastic housing
- Interchangeable Vaisala INTERCAP® humidity sensor
- Compatible with Vaisala Insight PC software and Vaisala Indigo80 Handheld Indicator
- Optional RS-485 digital output supports Modbus® RTU
- Optional dew/frost point, wet bulb temperature, absolute humidity, mixing ratio, and enthalpy output
- Temperature-only model HMP63T with digital output also available

Vaisala INTERCAP® Humidity and Temperature Probe HMP63 is a cost-effective humidity probe with a plastic housing. It is designed for non-condensing indoor environments or integration into other manufacturers' equipment.

Easy installation

The probe fits into tight spaces. The cable has a threaded M8 connector for easy installation. Different cable lengths are available and other compatible M8-series cables can also be used. Accessories are available for different installation needs.

Low power consumption

HMP63 is suitable for battery-powered applications thanks to its very low power consumption and fast start-up time.

Several output options

Temperature measurement is a standard feature in HMP63, with dew point temperature, wet bulb temperature, absolute humidity, mixing ratio, and

enthalpy as optional calculated parameters. Four voltage output ranges are available. An alternative RS-485 output with Modbus support is also available.

Output type, channel assignment of measurement parameters, and other probe features are configured when the probe is ordered.

Flexible connectivity

In addition to analog and digital (Modbus) output options, the probe can also be used with Vaisala Indigo80 Handheld Indicator. For easy-to-use access to configuration and device analytics functionalities, the probe can

be connected to Vaisala Insight PC software for Windows®. For more information, see vaisala.com/indigo80 and vaisala.com/insight.

Fast thermal response time

HMP63 has a PC/ABS plastic enclosure. It is ideal for environments with fast temperature changes where standard measurement accuracy is sufficient.

No recalibration required

HMP63 includes an interchangeable Vaisala INTERCAP® humidity sensor. No recalibration is required – the humidity sensor can simply be replaced, even in the field.

Technical data

Models

Model	Measurement	Special features
HMP63	RH + T	INTERCAP® humidity sensor
HMP63T	T	Digital output only, for use with CWL100 data logger

Measurement performance

Relative humidity	
Measurement range	0-100 %RH
Typical accuracy:	
at 0 ... +40 °C (+32 ... +140 °F)	±3 %RH (0-90 %RH) ±5 %RH (90-100 %RH)
at -40 ... 0 °C and +40 ... +60 °C (-40 ... +32 °F and +104 ... +140 °F)	±5 %RH (0-90 %RH) ±7 %RH (90-100 %RH)
Humidity sensor	Vaisala INTERCAP®
Temperature	
Measurement range	-40 ... +60 °C (-40 ... +140 °F)
Accuracy:	
at +10 ... +30 °C (+50 ... +86 °F)	±0.5 °C (±0.9 °F)
at -40 ... +10 and +30 ... +60 °C (-40 ... +50 and +86 ... +140 °F)	±0.6 °C (±1.08 °F)
Analog outputs	
Accuracy at 20 °C (+68 °F)	±0.2 % of FS
Temperature dependence	±0.01 % of FS/°C (±0.006 % of FS/°F)

Inputs and outputs

Power consumption	1 mA average, max. peak 5 mA
Operating voltage ¹⁾	
With 1 V / 2.5 V output	5-28 V DC
With 5 V output	8-28 V DC
With loop-power converter	8-28 V DC
With digital output	5-28 V DC
Start-up time	
Probes with analog output	4 s at operating voltage 13.5-16.5 V DC 2 s at other valid operating voltages
Probes with digital output	1 s
Outputs	
2 channels	0-1 V DC / 0-2.5 V DC / 0-5 V DC / 1-5 V DC
1-channel loop-power converter (separate module, compatible with humidity accuracy only)	4-20 mA
Digital output (optional)	RS-485 2-wire half duplex, supports Modbus RTU
External loads	
0-1 V	R _L min. 10 kΩ
Other voltage outputs	R _L min. 50 kΩ
Output parameters	
Relative humidity, temperature, dew/frost point temperature, wet bulb temperature, absolute humidity, mixing ratio, enthalpy	

¹⁾ Use lowest available operating voltage to minimize heating.

Operating environment

Operating temperature	-40 ... +60 °C (-40 ... +140 °F)
IP rating ¹⁾	IP54

¹⁾ Not applicable with the plastic grid filter.

Mechanical specifications

Cable connector	4-pin M8 (IEC 60947-5-2)
Materials	
Body	PC/ABS blend
Grid filter	PC (glass reinforced)
Cable	Polyurethane or FEP
Weight	
Probe	9 g (0.3 oz)
Probe with 0.3 m (1 ft) cable	20 g (0.7 oz)

Compliance

EU directives and regulations	EMC Directive (2014/30/EU) RoHS Directive (2011/65/EU) as amended by 2015/863
Electromagnetic compatibility (EMC)	EN 61326-1, basic electromagnetic environment
EMC emissions	CISPR 32 / EN 55032, Class B
Compliance marks	CE, RCM, UKCA

Spare parts and accessories

Sensors	
Vaisala INTERCAP® sensor, 1 pc	15778HM
Vaisala INTERCAP® sensor, 10 pcs	INTERCAPSET-10PCS
Sensor protection	
Plastic grid filter	DRW240185SP
Plastic grid with membrane filter	ASM210856SP
Stainless steel sintered filter	HM47280SP
Porous PTFE filter	219452SP
Probe installation	
Probe mounting clamp set, 10 pcs	226067
Probe mounting flange	226061
Probe holder, 5 pcs	ASM213382SP
Plastic locking bushing (3 pcs) for attaching probe to HM40	DRW238590SP
Connection adapters	
4-20 mA loop power converter	UI-CONVERTER-1CB
Mounting bracket for converter	225979
USB cable for PC connection	219690
Connection cable for Indigo80 handheld indicator	262195SP
Connection cable for HM70	219980SP
Connection cables with open wires	
+60 °C 0.3 m (+140 °F 1 ft)	HMP50Z032SP
+60 °C 1.2 m (+140 °F 4 ft)	HMP50Z120
+60 °C 3 m (+140 °F 9.8 ft)	HMP50Z300SP
+80 °C 1.5 m (+176 °F 5 ft)	225777SP
+80 °C 3 m (+176 °F 10 ft)	225229SP
+180 °C 1.5 m (+356 °F 5 ft) FEP	238025
+180 °C 3 m (+356 °F 10 ft) FEP	226902SP

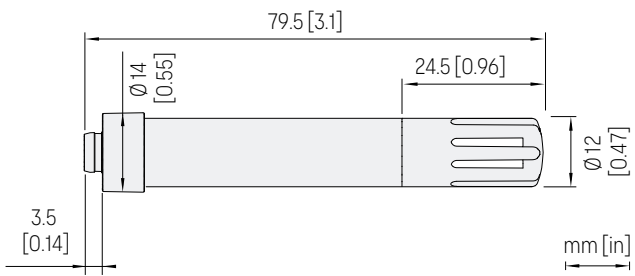

HMP63 probe dimensions

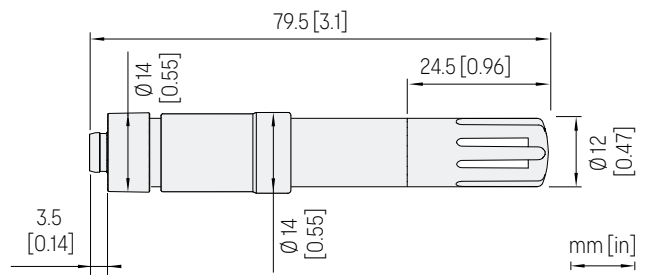

HMP63 and HMP63T probe dimensions with sleeve for CWL100 data logger

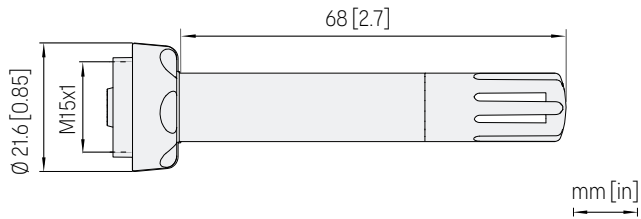

HMP63 probe dimensions with plastic locking bushing

HMP115 Humidity and Temperature Probe



Features

- Humidity and temperature probe designed for use with RFL100, CWL100, and VDL200 data loggers
- Measurement temperature range: -40 ... +60 °C (-40 ... +140 °F)
- Proven Vaisala HUMICAP® 180R sensor for excellent stability
- Fast thermal response time
- Low power consumption
- Temperature-only model HMP115T available
- Compatible with Vaisala Insight PC software and Vaisala Indigo80 Handheld Indicator
- Comes with calibration certificate: ±1.5 %RH measurement accuracy (0-90 %RH)

Vaisala HUMICAP® Humidity and Temperature Probe HMP115 is a highly accurate and cost-effective humidity probe with plastic enclosure. It is designed for indoor measurements with compatible Vaisala data loggers.

Designed for use with Vaisala data loggers

HMP115 provides an ideal solution for ambient measurement as it can be directly connected to the housing of Vaisala RFL100, CWL100, and VDL200 data loggers. It can also be connected using a cable for remote probe use.

High performance

HMP115 has a PC/ABS plastic enclosure and is suitable for non-condensing environments with fast temperature changes and a need for high-accuracy

measurements with traceability. HMP115 also has excellent chemical tolerance thanks to the proven Vaisala HUMICAP® 180R sensor.

Plastic grid filter provides the fastest response time. For added protection, select the membrane filter or the PTFE filter.

Low power consumption

HMP115 is suitable for battery-powered applications due to its very low power consumption. It also has an extremely fast start-up time.

Variety of calibration options

A quick field calibration can easily be carried out using a handheld device, for example, Vaisala Indigo80 Handheld Indicator or Vaisala Handheld Meter HM40. Alternatively, the probe can be calibrated using a PC with Vaisala Insight PC software and a compatible USB connection cable, or sent to Vaisala for calibration. Vaisala Service Centers offer both ISO 9001 and ISO 17025 calibrations.

Technical data

Measurement performance

Relative humidity	
Measurement range	0-100 %RH
Accuracy ¹⁾	
at 0 ... +40 °C (+32 ... +104 °F)	±1.5 %RH (0-90 %RH) ±2.5 %RH (90-100 %RH)
at -40 ... 0 °C (-40 ... +32 °F) and +40 ... +60 °C (+104 ... +140 °F)	±3.0 %RH (0-90 %RH) ±4.0 %RH (90-100 %RH)
Typical factory calibration uncertainty	±0.8 %RH
Humidity sensor	HUMICAP® 180R
Stability	±2 %RH over 2 years
Temperature	
Measurement range	-40 ... +60 °C (-40 ... +140 °F)
Accuracy	
at +15 ... +25 °C (+59 ... +77 °F)	±0.1 °C (±0.18 °F)
at 0 ... +40 °C (+32 ... +104 °F)	±0.2 °C (±0.36 °F)
at -40 ... 0 °C (-40 ... +32 °F) and +40 ... +60 °C (+104 ... +140 °F)	±0.4 °C (±0.72 °F)
Typical factory calibration uncertainty	±0.12 °C (±0.22 °F)
Temperature sensor	Pt1000 RTD Class F0.1 IEC 60751

¹⁾ Including non-linearity, hysteresis, and repeatability.

Operating environment

Operating temperature	-40 ... +60 °C (-40 ... +140 °F)
Operating humidity	0-100 %RH, non-condensing
IP rating ¹⁾	IP54

¹⁾ Not applicable with the plastic grid filter.

Compliance

EU directives and regulations	RoHS Directive (2011/65/EU) as amended by 2015/863
Electromagnetic compatibility (EMC)	EN 61326-1, industrial environment
Compliance marks	CE, RCM

Inputs and outputs

Power consumption	1 mA average, max. peak 5 mA
Operating voltage	5-28 V DC
Start-up time	1 s
Digital output	RS-485 2-wire half duplex, supports Modbus RTU

Output parameters

Output parameter	HMP115	HMP115T
Temperature (°C)	✓	✓
Relative humidity (%RH)	✓	

Mechanical specifications

Cable connector	4-pin M8 (IEC 60947-5-2)
Weight	9 g (0.3 oz)
Materials	
Body	PC/ABS blend
Grid filter	PC (glass reinforced)

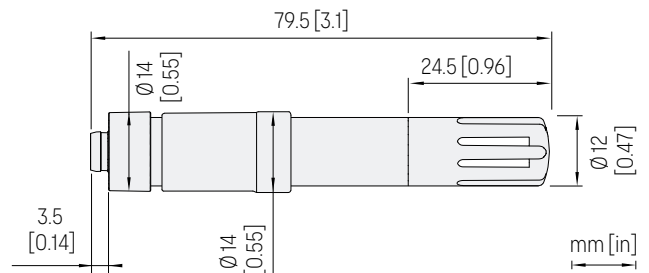

HMP115 dimensions

Accessories

Probe holder, 5 pcs	ASM213382SP
USB cable for PC connection	219690
Connection cable for Indigo80 handheld indicator	262195SP
Connection cable for MI70 indicator	219980SP
Connection cable for HM40 handheld meter	HMT120Z300



Features

- Miniature-size humidity transmitter
- Low power consumption and fast start-up for battery-powered applications
- Measurement range: 0–100 %RH; –40 ... +80 °C (–40 ... +176 °F)
- Cable detachable with standard M8 quick connector
- IP65 metal housing
- Compatible with Vaisala Insight PC software and Vaisala Indigo80 handheld indicator
- Optional RS-485 digital output supports Modbus® RTU
- ±1.5 %RH measurement accuracy (0–90 %RH)
- Temperature-only model HMP110T also available

Vaisala HUMICAP® Humidity and Temperature Probe HMP110 is a trouble-free and cost-effective humidity transmitter with high accuracy and good stability. It is suitable for volume applications or integration into other manufacturers' equipment. HMP110 is also suitable for glove boxes, greenhouses, fermentation and stability chambers, data loggers, and incubators.

Benefits

- Latest generation Vaisala HUMICAP® 180R sensor for best stability and high chemical tolerance
- Comes with calibration certificate
- Optional dew/frost point, wet bulb temperature, absolute humidity, mixing ratio, and enthalpy calculation

Easy installation

The probe cable has a screw-on quick connector for easy installation. Different cable lengths and accessories are available.

Low current consumption

HMP110 is suitable for battery-powered applications because of its very low current consumption. It also has a fast start-up time.

Several outputs

Temperature measurement is a standard feature in the HMP110, with dew/frost point temperature, wet bulb temperature, absolute humidity, mixing ratio, and enthalpy as optional calculated parameters. Three standard voltage outputs are available. An optional RS-485 output with Modbus support is also available.

Flexible connectivity

In addition to analog and digital (Modbus) output options, the probe can also be used with the Vaisala Indigo80 handheld indicator. For easy-to-use

access to configuration and device analytics functionalities, the probe can be connected to Vaisala Insight software for Windows®. For more information, see www.vaisala.com/insight and www.vaisala.com/indigo80.

Robust design

The stainless steel body of HMP110 is classified as IP65, making it ideal for rough conditions. HMP110 has high chemical tolerance thanks to the HUMICAP® 180R sensor.

Technical data

Models

Model	Output	Special features
HMP110	RH+T	-
HMP110T	T	-
HMP110REF	-	Fixed output probe for validation of HMT120 and HMT130 transmitters

Measurement performance

Relative humidity	
Measurement range	0-100 %RH
Accuracy: ^{1) 2)}	
at 0 ... +40 °C (+32 ... +104 °F)	±1.5 %RH (0-90 %RH) ±2.5 %RH (90-100 %RH)
at -40 ... 0 °C (-40 ... +32 °F) and +40 ... +80 °C (+104 ... +176 °F)	±3.0 %RH (0-90 %RH) ±4.0 %RH (90-100 %RH)
Factory calibration uncertainty at +20 °C (+68 °F)	±1.1 %RH (0-90 %RH) ±1.8 %RH (90-100 %RH)
Humidity sensor types	HUMICAP® 180R HUMICAP® 180V
Stability	±2 %RH over 2 years
T ₉₀ response time	With plastic grid filter: approx. 17 s With membrane filter: approx. 20s With stainless steel sintered filter: approx. 60 s

Temperature	
Measurement range	-40 ... +80 °C (-40 ... +176 °F)
Accuracy (probes with analog output):	
at 0 ... +40 °C (+32 ... +104 °F)	±0.2 °C (±0.36 °F)
at -40 ... 0 °C (-40 ... +32 °F) and +40 ... +80 °C (+104 ... +176 °F)	±0.4 °C (±0.72 °F)
Accuracy (probes with digital output):	
at +15 ... +25 °C (+59 ... +77 °F)	±0.1 °C (±0.18 °F)
at 0 ... +15 °C (+ 32 ... +59 °F) and +25 ... +40 °C (+77 ... +104 °F)	±0.15 °C (±0.27 °F)
at -40 ... 0 °C (-40 ... +32 °F) and +40 ... +80 °C (+104 ... +176 °F)	±0.4 °C (±0.72 °F)
Temperature sensor	Pt1000 RTD Class F0.1 IEC 60751
Analog outputs	
Accuracy at +20 °C (+68 °F)	±0.2 % of FS
Temperature dependence	±0.01 % of FS/°C (±0.006 % of FS/°F)

¹⁾ Including non-linearity, hysteresis, and repeatability.

²⁾ With HUMICAP® 180V sensor, accuracy is not specified below -20 °C (-4 °F) operating temperature.

Operating environment

Operating temperature	-40 ... +80 °C (-40 ... +176 °F)
IP rating ¹⁾	IP65

¹⁾ Not applicable with the plastic grid filter.

Compliance

EU directives and regulations	EMC Directive (2014/30/EU) RoHS Directive (2011/65/EU) as amended by 2015/863
Electromagnetic compatibility (EMC)	EN 61326-1, industrial environment
EMC emissions	CISPR 32 / EN 55032, Class B
Compliance marks	CE, RCM, UKCA

Inputs and outputs

Power consumption	1 mA average, max. peak 5 mA
Operating voltage ¹⁾	
With 1 V / 2.5 V output	5-28 V DC
With 5 V output	8-28 V DC
With loop power converter	8-28 V DC
With digital output	5-28 V DC
Start-up time	
HMP110 probes with analog output	4 s at operating voltage 13.5-16.5 V DC 2 s at other valid operating voltages
HMP110 probes with digital output	1 s
Outputs	
2 channels	0-1 V DC / 0-2.5 V DC / 0-5 V DC / 1-5 V DC
1-channel loop-power converter (separate module, compatible with humidity accuracy only)	4-20 mA
Digital output (HMP110 probes with digital output)	RS-485 2-wire half duplex, supports Modbus RTU
External loads	
0-1 V	R _L min. 10 kΩ
Other voltage outputs	R _L min. 50 kΩ

Output parameters	
Relative humidity, temperature, dew/frost point temperature, wet bulb temperature, absolute humidity, mixing ratio, enthalpy	

¹⁾ Use lowest available operating voltage to minimize heating.

Mechanical specifications

Body thread	M12x1 / 10 mm (0.4 in)
Cable connector	M8 4-pin female (IEC 60947-5-2)
Materials	
Body	Stainless steel (AISI 316)
Grid filter	Chrome coated ABS plastic
Cable	Polyurethane or FEP
Weight	
Probe	17 g (0.6 oz)
Probe with 0.3 m (1 ft) cable	28 g (1 oz)

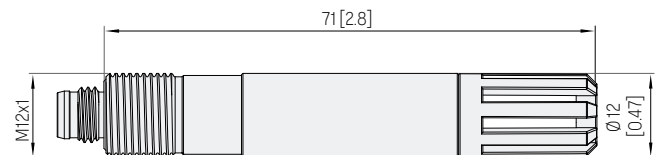

HMP110 and HMP110T probe dimensions

Spare parts and accessories

Sensors

Vaisala HUMICAP® 180R HUMICAP180R

Vaisala HUMICAP® 180V HUMICAP180V

Sensor protection

Plastic grid filter DRW010522SP

Membrane filter DRW010525SP

Stainless steel sintered filter HM46670SP

PTFE membrane filter with stainless steel grid ASM212652SP

PTFE sintered filter DRW244938SP

Probe installation

Duct installation kit 215619

Probe mounting clamp set, 10-pcs 226067

Probe mounting flange 226061

Probe holder, 5 pcs ASM213382SP

Plastic M12 installation nuts, pair 18350SP

Flat extension cable 1 m (3 ft) ¹⁾ CBL210649SP

Connection adapters

4-20-mA loop power converter UI-CONVERTER-1CB

Mounting bracket for converter 225979

USB cable for PC connection 219690

Connection cable for Indigo80 handheld indicator 262195SP

Connection cable for MI70 indicator 219980SP

Connection cables with open wires

+60-°C 0.3-m (+140-°F 1-ft) HMP5OZ032SP

+60-°C 1.2-m (+140-°F 4-ft) HMP5OZ120

+60-°C 3-m (+140-°F 9.8-ft) HMP5OZ300SP

+80-°C 1.5-m (+176-°F 5-ft) 225777SP

+80-°C 3-m (+176-°F 10-ft) 225229SP

+180-°C 1.5-m (+356-°F 5-ft) FEP 238025

+180-°C 3-m (+356-°F 10-ft) FEP 226902SP

¹⁾ Connection cable 219980SP is also needed if this cable is used with MI70 indicator.



Features

- Measurement range 0 ... 20 %CO₂
- Intelligent, standalone probe with analog and digital outputs
- Compatible with Vaisala Indigo products, Insight PC software, and RFL100 data logger
- Wide operating temperature range (-40 ... +60 °C) (-40 ... +140 °F)
- IP65-classified housing
- Integrated temperature measurement for CO₂ compensation purposes
- Compensations also for pressure, oxygen, and humidity
- Sensor head heated to prevent condensation

Vaisala CARBOCAP® Carbon Dioxide Probe GMP251 is an intelligent probe for measuring carbon dioxide. This robust, standalone measurement device is designed for use in demanding applications, such as life science incubators, where stable, reliable, and accurate performance is required.

Benefits

- Excellent long-term stability
- Reliable and accurate
- Calibration certificate included

GMP251 is based on Vaisala's patented, latest-generation CARBOCAP technology that enables exceptional stability. A new type of infrared (IR) light source is used instead of the traditional incandescent light bulb, which extends the lifetime of GMP251.

GMP251 incorporates an internal temperature sensor for compensation of the CO₂ measurement according to ambient temperature. The effects of pressure and background gas can also be compensated for. The measurement range is 0 ... 20 %CO₂ and the sensor performance is optimized at 5 %CO₂ measurement.

The operating temperature range of the probe is wide (-40 ... +60 °C (-40 ... +140 °F)), and the probe housing is classified as IP65. Condensation is prevented as the internal sensor head is heated. GMP251 is resistant to dust and most chemicals, such as H₂O₂ and alcohol-based cleaning agents.

Ease of use

GMP251 is a compact probe with easy and fast plug-in, plug-out installation. The surface of the probe is smooth, which makes it easy to clean. The probe provides several output options, including analog current and voltage outputs and digital RS-485 output with Modbus® protocol.

GMP251 can be connected to Indigo series transmitters and the Indigo80 handheld indicator for an extended range of output and configuration options. See www.vaisala.com/indigo.

For easy-to-use access to field calibration, device analytics, and configuration functionality, the probe can be connected to Vaisala Insight software for Windows®. See www.vaisala.com/insight.

Applications

GMP251 is ideal for life science incubators, cold storages, fruit and vegetable transportation, and for all demanding applications where stable and accurate %-level CO₂ measurements are needed.

A flow-through adapter with gas ports is available as an accessory, enabling tubing for easy and flexible remote measurement with a separate pump. A multiplexer can also be added for sampling gas from several locations. ¹⁾

1) Third-party pump and multiplexer not provided by Vaisala.

Technical data

Measurement performance

Measurement range	0-20 %CO ₂
Accuracy ¹⁾	
At 5 %CO ₂	±0.1 %CO ₂
At 0-8 %CO ₂	±0.2 %CO ₂
At 8-20 %CO ₂	±0.4 %CO ₂
Calibration uncertainty	
At 5 %CO ₂	±0.07 %CO ₂
At 20 %CO ₂	±0.27 %CO ₂
Long-term stability	
At 0-8 %CO ₂	±0.3 %CO ₂ /year
At 8-12 %CO ₂	±0.5 %CO ₂ /year
at 12-20 %CO ₂	±1.0 %CO ₂ /year
Temperature dependence	
With compensation at 5 %CO ₂ , 0 ... +50 °C (+32 ... +122 °F)	< ±0.05 %CO ₂
With compensation, 0-20 %CO ₂ , -40 ... +60 °C (-40 ... +140 °F)	±0.045 % of reading/°C
without temperature compensation at 5 %CO ₂ (typical)	-0.25 % of reading/°C
Pressure dependence	
With compensation at 5 %CO ₂ 700- 1100 hPa	±0.05 %CO ₂
With compensation, 0-20 %CO ₂ 500- 1100 hPa	±0.015 % of reading/hPa
Without compensation (typical)	+0.15 % of reading/hPa
Humidity dependence	
With compensation, 0-20 %CO ₂ , 0- 100 %RH	±0.7 % of reading (at +25 °C (+77 °F))
Without compensation (typical)	+0.05 % of reading / %RH
O₂ dependence	
With compensation, 0-20 %CO ₂ , 0- 90 %O ₂	±0.6 % of reading (at +25 °C (+77 °F))
Without compensation (typical)	-0.08 % of reading / %O ₂
Start-up, warm-up, and response time	
Start-up time at +25 °C (+77 °F)	< 10 s
Warm-up time for full spec.	< 4 min
Response time (T90):	
With standard filter	< 1 min
Flow-through option with > 0.1 l/min	< 1 min
With spray shield	< 2 min
Flow rate dependence (for flow-through option)	
Flow rate dependence:	
< 1 l/min flow	No effect
1-10 l/min flow	< 0.6 % of reading/ l/min

¹⁾ At 25 °C (77 °F) and 1013 hPa (incl. repeatability and non-linearity).

Compliance

EU directives and regulations	EMC, RoHS
Electromagnetic compatibility (EMC)	EN 61326-1, basic electromagnetic environment
EMC emissions	CISPR 32 / EN 55032, Class B
Compliance marks	CE, China RoHS, RCM

Operating environment

Operating temperature of CO ₂ measurement	-40 ... +60 °C (-40 ... +140 °F) ¹⁾
Storage temperature	-40 ... +70 °C (-40 ... +158 °F)
Humidity	0-100 %RH, non-condensing
Condensation prevention	Sensor head heating, when power on
IP rating, probe body	IP65
Chemical tolerance (temporary exposure during cleaning)	<ul style="list-style-type: none"> • H₂O₂ (2000 ppm, non-condensing) • Alcohol-based cleaning agents (for example ethanol and IPA) • Acetone • Acetic acid
Pressure	
Compensated	500-1100 hPa
Operating	< 1.5 bar
Gas flow (for flow-through option)	
Operating range	< 10 l/min
Recommended range	0.1-0.8 l/min

¹⁾ Occasional short-term exposure to up to +90 °C (+194 °F) allowed, provided that the probe is fully installed inside the measured condition and power is switched on. Accuracy specification not applicable if used in temperatures above +60 °C (+140 °F).

Mechanical specifications

Weight, probe	45 g (1.59 oz)
Connector type	M12 5-pin male
Materials	
Probe housing	PBT polymer
Filter	PTFE membrane, PBT polymer grid
Connector	Nickel plated brass
Dimensions	
Probe diameter	25 mm (0.98 in)
Probe length	96 mm (3.78 in)

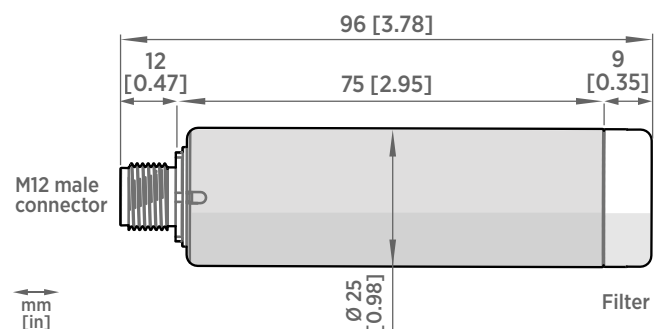

GMP251 dimensions

Inputs and outputs

Analog outputs	<ul style="list-style-type: none"> 0–5/10 V (scalable), min. load 10 kΩ 0/4–20 mA (scalable), max. load 500 Ω
Digital output	Over RS-485: <ul style="list-style-type: none"> Modbus Vaisala Industrial Protocol
Operating voltage	
With digital output in use	12–30 V DC
With voltage output in use	12–30 V DC
With current output in use	20–30 V DC
Power consumption	
Typical (continuous operation)	0.4 W
Maximum	0.5 W

Spare parts and accessories

Standard membrane filter	ASM211650SP
Porous sintered PTFE filter	DRW243649SP
Probe connection cable with open wires (1.5 m), shielded	223263SP
Probe connection cable with open wires (1.5 m), shielded	254294SP
Probe connection cable with open wires (3 m), shielded	26719SP
Probe connection cable with open wires (10 m), shielded	216546SP
Probe connection cable with open wires and 90° plug (0.6 m), shielded	244669SP
Probe connection cable with open wires and 90° plug (1.5 m), shielded	255102
MI70 connection cable, M12 5-pin	CBL210472
Connection cable for Indigo80, M12-5F - M12-5M, 1.5 m	272075SP
Flat cable for GMP250 probes, M12 5-pin	CBL210493SP
Indigo USB adapter ¹⁾	USB2
Probe mounting clips (2 pcs)	243257SP
Probe mounting flange	243261SP
Probe holder assembly	ASM213582
Flow-through adapter with gas ports	ASM211697SP
Calibration adapter	DRW244827SP
Spray shield	ASM212017SP

¹⁾ Vaisala Insight software for Windows available at vaisala.com/insight

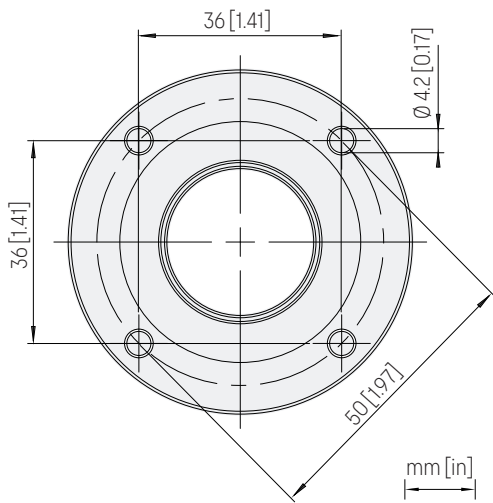

Probe mounting flange 243261SP dimensions

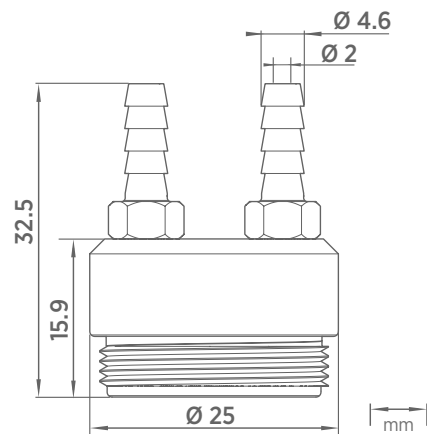

Flow-through adapter with gas ports ASM211697SP. Suitable for tubes with 4 mm inner diameter.

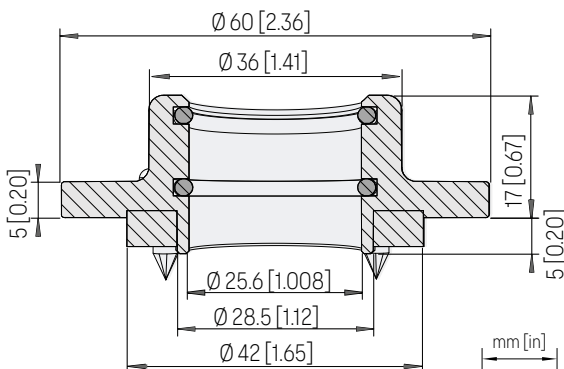

Probe mounting flange 243261SP dimensions, cross section

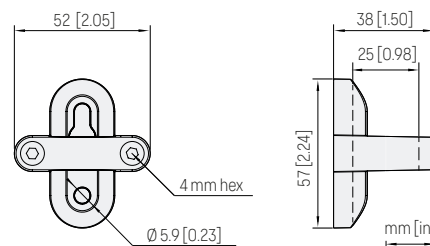

Probe holder ASM213582 dimensions

GMP252 Carbon Dioxide Probe For ppm-level measurements



Features

- Measurement range
0 ... 10 000 ppm CO₂
- Intelligent, standalone probe with analog and digital outputs
- Compatible with Vaisala Indigo products and Insight PC software
- Wide operating temperature range, -40 ... +60 °C (-40 ... +140 °F)
- IP65-classified housing
- Integrated temperature measurement for CO₂ compensation purposes
- Compensations also for pressure, oxygen, and humidity
- Sensor head heated to prevent condensation

Vaisala CARBOCAP® Carbon Dioxide Probe GMP252 is an intelligent probe for measuring carbon dioxide. This robust, standalone measurement device is designed for use in agriculture, refrigeration, greenhouses, and demanding HVAC applications.

Benefits

- Excellent long-term stability
- Reliable and accurate
- Calibration certificate included

GMP252 is suitable for harsh and humid CO₂ measurement environments where stable and accurate ppm-level CO₂ measurements are needed. GMP252 is based on Vaisala's patented, latest-generation CARBOCAP technology that enables exceptional stability. A new type of infrared (IR) light source is used instead of the traditional incandescent light bulb, which extends the lifetime of GMP252.

GMP252 incorporates an internal temperature sensor for compensation of the CO₂ measurement according to ambient temperature. The effects of pressure and background gas can also be compensated for. The measurement

range is 0 ... 10 000 ppm CO₂ (measurements up to 30 000 ppm CO₂ are available with reduced accuracy). The operating temperature range of the probe is wide (-40 ... +60 °C (-40 ... +140 °F)), and the probe housing is classified as IP65. Condensation is prevented as the internal sensor head is heated.

GMP252 is resistant to dust and most chemicals, such as H₂O₂ and alcohol-based cleaning agents.

Ease of use

GMP252 is a compact probe with easy and fast plug-in, plug-out installation. The surface of the probe is smooth, which makes it easy to clean. The probe provides several output options, including analog current and voltage outputs and digital RS-485 output with Modbus® protocol.

GMP252 can be connected to Indigo series transmitters and the Indigo80 handheld indicator for an extended range of outputs and configuration options. See www.vaisala.com/indigo.

For easy-to-use access to field calibration, device analytics, and configuration functionality, the probe can be connected to Vaisala Insight software for Windows®. See www.vaisala.com/insight.

Applications

GMP252 is ideal for agriculture, refrigeration, greenhouses, and demanding HVAC applications where stable and accurate ppm-level CO₂ measurements are needed.

A flow-through adapter with gas ports is available as an accessory, enabling tubing for easy and flexible remote measurement with a separate pump. A multiplexer can also be added for sampling gas from several locations. ¹⁾

¹⁾ Third-party pump and multiplexer not provided by Vaisala.

Technical data

Measurement performance

Measurement range	0–10 000 ppm CO ₂ (up to 30 000 ppm CO ₂ with reduced accuracy)
Accuracy ¹⁾	
0–3000 ppm CO ₂	±40 ppm CO ₂
3000–10 000 ppm CO ₂	±2 % of reading
Up to 30 000 ppm CO ₂	±3.5 % of reading
Calibration uncertainty	
at 2000 ppm CO ₂	±31 ppm CO ₂
at 10 000 ppm CO ₂	±105 ppm CO ₂
Long-term stability	
0–3000 ppm CO ₂	±60 ppm CO ₂ /year
3000–6000 ppm CO ₂	±150 ppm CO ₂ /year
6000–10 000 ppm CO ₂	±300 ppm CO ₂ /year
Temperature dependence 0–10 000 ppm CO₂	
With compensation, –10 ... +50 °C	±0.05 % of reading/°C
With compensation, –40 ... +60 °C	< ±0.1 % of reading/°C
Without temperature compensation at 2000 ppm CO ₂ (typical)	–0.5 % of reading/°C
Pressure dependence	
With compensation at 0–10 000 ppm CO ₂ , 500–1100 hPa	±0.015 % of reading/hPa
Without compensation (typical)	+0.15 % of reading/hPa
Humidity dependence	
With compensation, 0–10 000 ppm CO ₂ , 0–100 %RH	±0.7 % of reading (at +25 °C (+77 °F))
Without compensation (typical)	+0.05 % of reading/%RH
O₂ dependence	
With compensation, 0–10 000 ppm %CO ₂ , 0–90 %O ₂	±0.6 % of reading (at +25 °C (+77 °F))
Without compensation (typical)	–0.08 % of reading/%O ₂
Start-up, warm-up, and response time	
Start-up time at +25 °C	< 12 s
Warm-up time for full spec.	< 2 min
Response time (T ₉₀):	
With standard filter	< 1 min
Flow-through option with > 0.1 l/min	30 s
With spray shield	< 3 min
Flow rate dependence (for flow-through option)	
< 1 l/min flow	No effect
1–10 l/min flow	< 0.6 % of reading l/min

¹⁾ At 25 °C (77 °F) and 1013 hPa (incl. repeatability and non-linearity).

Inputs and outputs

Analog outputs	<ul style="list-style-type: none"> 0–5/10 V (scalable), min. load 10 kΩ 0/4–20 mA (scalable), max. load 500 Ω
Digital output	Over RS-485: <ul style="list-style-type: none"> Modbus Vaisala Industrial Protocol
Operating voltage	
With digital output in use	12–30 V DC
With voltage output in use	12–30 V DC
With current output in use	20–30 V DC
Power consumption	
Typical (continuous operation)	0.4 W
Maximum	0.5 W

Operating environment

Operating temperature of CO ₂ measurement	–40 ... +60 °C (–40 ... +140 °F)
Storage temperature	–40 ... +70 °C (–40 ... +158 °F)
Operating humidity	0–100 %RH, non-condensing
Condensation prevention	Sensor head heating when power on
IP rating, probe body	IP65
Chemical tolerance (temporary exposure during cleaning)	<ul style="list-style-type: none"> H₂O₂ (2000 ppm, non-condensing) Alcohol-based cleaning agents (for example ethanol and IPA) Acetone Acetic acid
Pressure	
Compensated	500–1100 hPa
Operating	< 1.5 bar
Gas flow (for flow-through option)	
Operating range	< 10 l/min
Recommended range	0.1–0.8 l/min

Compliance

EU directives and regulations	EMC, RoHS
Electromagnetic compatibility (EMC)	EN 61326-1, basic electromagnetic environment
EMC emissions	CISPR 32 / EN 55032, Class B
Compliance marks	CE, RCM

Mechanical specifications

Weight, probe	58 g (2.05 oz)
Connector type	M12 5-pin male
Materials	
Probe housing	PBT polymer
Filter	PTFE
Connector	Nickel-plated brass
Dimensions	
Probe diameter	25 mm (0.98 in)
Probe length	130 mm (5.12 in)

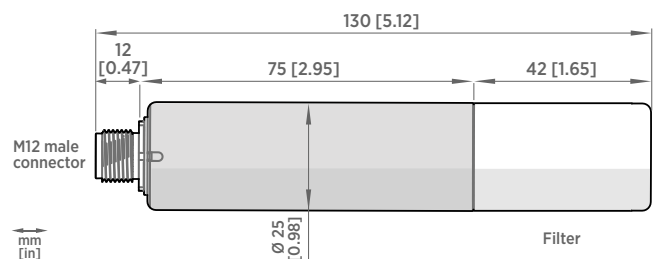

GMP252 probe dimensions

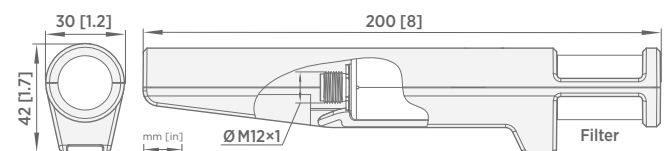

GMP252 probe handle dimensions

Spare parts and accessories

Porous sintered PTFE filter for GMP252	DRW244221SP
Probe connection cable with open wires (1.5 m), shielded	223263SP
Probe connection cable with open wires (1.5 m), shielded	254294SP
Probe connection cable with open wires (3 m), shielded	26719SP
Probe connection cable with open wires (10 m), shielded	216546SP
Probe connection cable with open wires and 90° plug (0.6 m), shielded	244669SP
Probe connection cable with open wires and 90° plug (1.5 m), shielded	255102
M170 connection cable, M12 5-pin	CBL210472
Connection cable for Indigo80, M12-5F - M12-5M, 1.5 m	272075SP
Flat cable for GMP250 probes, M12 5-pin	CBL210493SP
Indigo USB adapter ¹⁾	USB2
Probe mounting clips (2 pcs)	243257SP
Probe mounting flange	243261SP
Probe holder assembly	ASM213582
Probe handle with magnetic hanger	GMP252HANDLESP
Probe handle	ASM214342SP
Flow-through adapter with gas ports	ASM212011SP
Calibration adapter	DRW244827SP
Spray shield	ASM212017SP
Radiation shield DTR250	DTR250
Radiation shield DTR250 with pole mounting kit	DTR250A

¹⁾ Vaisala Insight software for Windows is available at www.vaisala.com/insight.

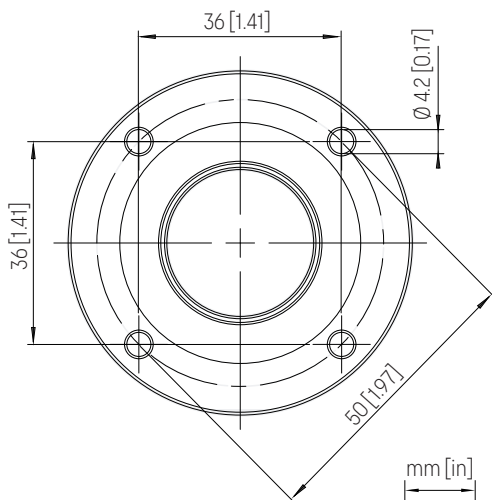

Probe mounting flange 243261SP dimensions

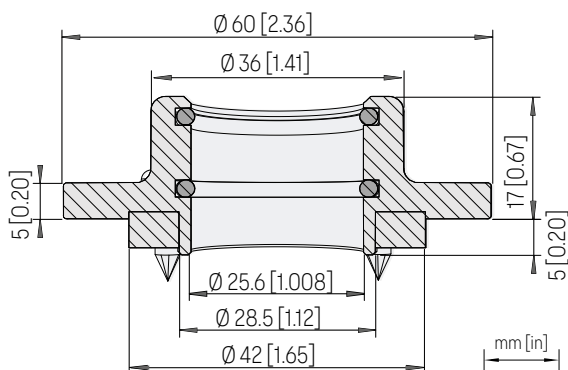

Probe mounting flange 243261SP dimensions, cross section

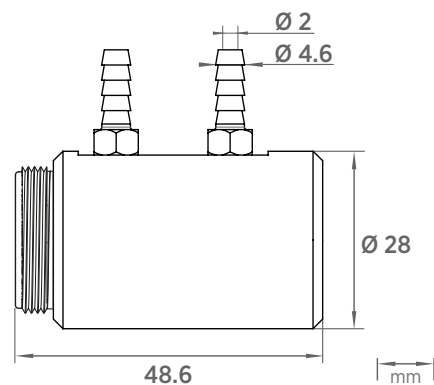

Flow-through adapter with gas ports ASM212011SP. Suitable for tubes with 4 mm inner diameter.

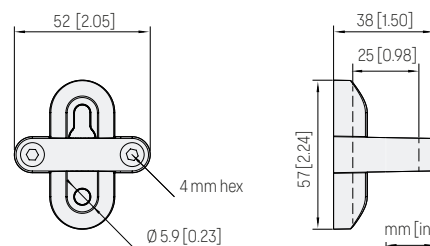

Probe holder ASM213582 dimensions



Features

- Converts one current, voltage, or contact input to digital output
- Compatible with Vaisala VDL200 data logger
- Easy configuration with Insight PC software
- Preconfigured door switch model available
- Optional M8 field connector kit
- Traceable to SI units through national metrology institutes

Connect a wide range of analog sensors through ANP115 Analog Input Probe to VDL200 data logger. ANP115 converts current, voltage, or contact input to VDL200 compatible digital format. This enables recording the data to your Vaisala monitoring system.

Expand your monitoring capability

ANP115 is a simple solution for integrating more parameters to your Vaisala monitoring system. Add measurements such as differential pressure, flow, fluid level, electrical properties, gas concentrations, and many more.

ANP115 provides several installation options. The standard ANP115 model has open wires and an M8 field connector kit is available. A door switch model is also available and requires no configuration.

Versatile configuration

Easily configure ANP115 to match the properties of your analog sensor using Vaisala Insight software.

Based on the analog sensor, choose from a wide selection of parameters and measurement units. You can freely set the scaling of the analog signal.

ANP115 also supports a wide range of passive and active contacts.

ANP115 can also be configured to supply operating power to the analog sensor.

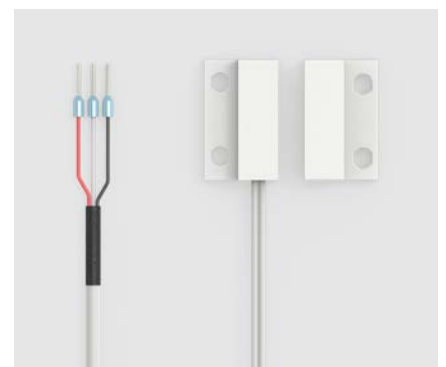

ANP115 open wires model and door switch model

Technical data

Operating environment

Operating environment	Indoor use
Use in wet location	No
Operating humidity	0-100 %RH, non-condensing
IP rating of probe body	IP65
Operating temperature	
Open wires model	-40 ... +60 °C (-40 ... +140 °F)
Door switch model ¹⁾	-20 ... +60 °C (-4 ... +140 °F)

¹⁾ Magnetic reed switch wires must be fixed in place.

Powering

Operating voltage ¹⁾	5-28 V DC
Powering from VDL200 data logger	
Operating voltage	15 V DC
Output voltage	15 V DC
Current consumption	max. 30 mA

¹⁾ This table shows the powering provided to the analog sensor by Vaisala host devices. If additional power is needed, an external powering device is needed for the analog sensor.

Inputs and outputs

Digital output	RS-485 2-wire half duplex, supports Modbus RTU
PC interface	Vaisala Insight PC software, version 1.3.0 or newer ¹⁾

Open wires model²⁾

Current input:	
Available ranges	4-20 mA, 0-20 mA, scalable
Resolution	300 nA
Accuracy of current input at +23 °C (+73.4 °F)	0.03 mA
Temperature dependence	±0.015 % / °C full scale
Input impedance	50 Ω
Overload protection	30 mA max. (reverse polarity protected)
Voltage input:	
Available ranges	0-5 V, 0-10 V, scalable
Resolution	200 μV
Accuracy of voltage input at +23 °C (+73.4 °F)	0.015 V
Temperature dependence	±0.005 % / °C full scale
Input impedance	40 kΩ
Overload protection	30 V (reverse polarity protected)
Boolean input:	
Functions	Supports both passive and active contacts, can be configured to normally open or normally closed.

Preconfigured door switch model

Open	Distance from magnet > 15 mm (0.59 in)
Closed	Distance from magnet < 15 mm (0.59 in)

¹⁾ Vaisala Insight software is available for download at [vaisala.com/insight](https://www.vaisala.com/insight).
²⁾ Configurable to current input, voltage input, or boolean input.

Compliance

EU directives and regulations	EMC Directive (2014/30/EU) RoHS Directive (2011/65/EU) as amended by 2015/863
Electromagnetic compatibility (EMC)	IEC/EN 61326-1, industrial environment EN 61000-6-2 EN 61000-6-4 FCC part 15 B, Class B ICES-3 / NMB-3 (Class B)
Compliance marks	CE, China RoHS, KC, RCM

Mechanical specifications

Weight	25 g (0.88 oz)
Materials	
Probe body	PC/ABS blend
Cable jacket	Polyurethane (PU)
Connectors	
Probe connector	4-pin male M8 (IEC 60947-5-2)
Analog input connection	Open wires or 4-pin male M8 (IEC 60947-5-2)
Door switch	Magnetic reed switch wire connections

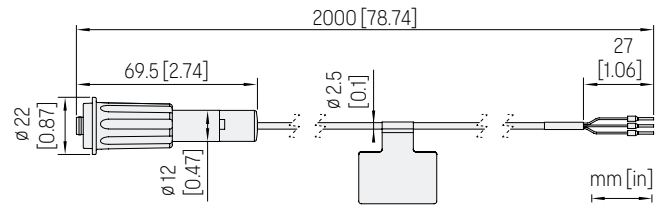

Open wires model dimensions

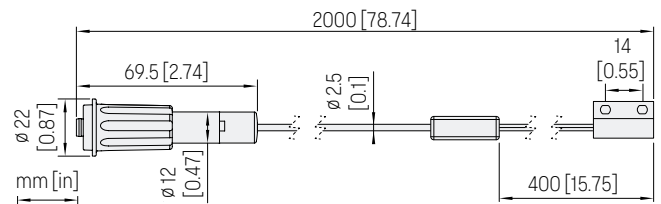

Door switch model dimensions

Accessories

USB cable for PC connection	219690
-----------------------------	--------

HPP270 Series Probes

For hydrogen peroxide, humidity, and temperature measurement

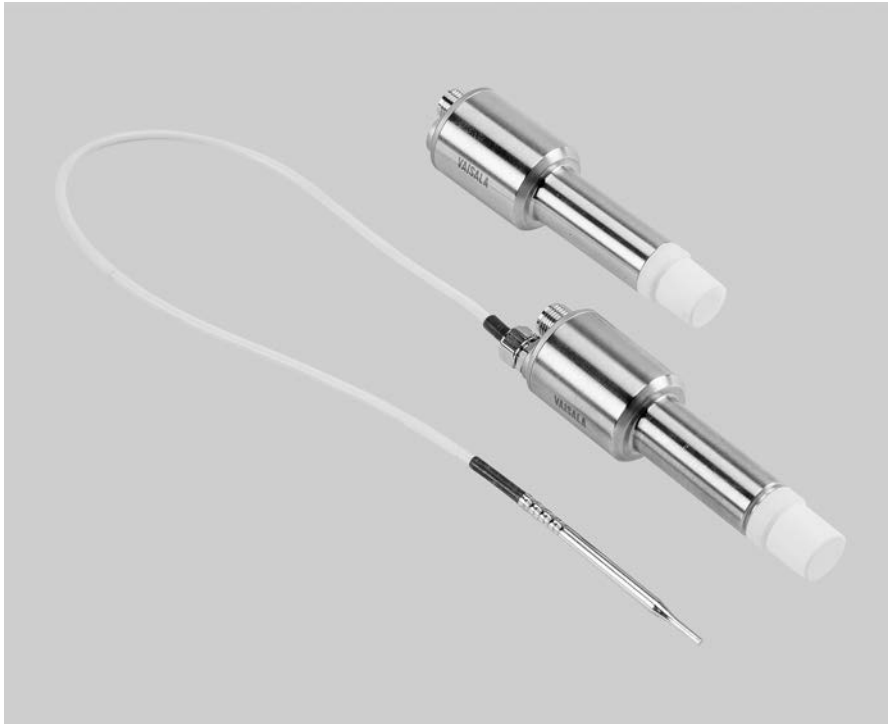

Features

- Basic probe option HPP271 for H₂O₂ vapor concentration measurement
- Advanced probe option HPP272: compact 3-in-1 probe with real-time measurement of H₂O₂ vapor concentration, humidity, and temperature
- Superior long-term stability and repeatability with proprietary PEROXCAP® technology
- Corrosion-resistant stainless steel housing (IP65)
- Traceable calibration certificate
- Standalone probe with digital Modbus RTU over RS-485 or 2 analog outputs
- Compatible with Vaisala Indigo products and Insight PC software

The Vaisala PEROXCAP® Hydrogen Peroxide, Humidity, and Temperature Probes HPP271 and HPP272 are designed for demanding hydrogen peroxide bio-decontamination where repeatable, stable, and accurate measurement is essential. The HPP270 series probes are suitable for a variety of applications such as isolator, material transfer hatch, and room bio-decontamination.

Up to three measurements in one compact unit

The advanced HPP272 probe option provides all the parameters you need to measure during bio-decontamination processes: hydrogen peroxide vapor, temperature, and humidity as relative saturation and relative humidity.

Relative saturation for comprehensive humidity monitoring

Similar to water, H₂O₂ vapor affects the humidity level of decontaminated air. The advanced HPP272 probe option enables the measurement of relative saturation, which indicates the total humidity level caused by water vapor and H₂O₂ vapor together. This tells you reliably when the bio-decontaminated air starts to condense.

Repeatable measurement for highly condensing environments

Intelligent measurement technology including the sensor purge function helps to maintain accuracy between calibrations in challenging H₂O₂ environments. The purging process involves rapid heating of the sensor to remove possible contamination.

The PEROXCAP® sensor used in the HPP270 series probes is warmed, which prevents condensation from forming on the sensor. This provides reliable measurement even in condensing conditions.

Indigo and Insight compatible

The probe can be connected to Vaisala Indigo transmitters and the Indigo80 handheld indicator to extend the selection of available features.

Indigo products provide a range of additional display, output, and relay options, as well as convenient interfaces for monitoring, configuration, and calibration and adjustment. For more information, see www.vaisala.com/indigo.

For easy-to-use access to configuration, calibration, and adjustment, the probe can be connected to Vaisala Insight PC software. See www.vaisala.com/insight.

Traceable calibration at Vaisala

Every probe and sensor is manufactured and individually calibrated at Vaisala world-class facilities. Available traceable calibration certificates: 2 points for H₂O₂, 3 points for humidity, 1 point for temperature.

HPP271 technical data

Measurement performance

Hydrogen peroxide	
Sensor	PEROXCAP®
Measurement range	0 ... 2000 ppm
Measurement temperature range	+5 ... +50 °C (+41 ... +122 °F)
Repeatability at +25 °C (+77 °F) up to 500 ppm H ₂ O ₂	±10 ppm
Accuracy at +10 ... +25 °C (+50 ... +77 °F), 10 ... 2000 ppm H ₂ O ₂ ¹⁾	±10 ppm or 5 % of reading (whichever is greater)
Factory calibration uncertainty at +25 °C (+77 °F), 500 ppm H ₂ O ₂ ²⁾	±10 ppm
Response time (T ₆₃)	70 s
Other parameters	
H ₂ O ppm by volume, dew point temperature	

1) Including non-linearity, hysteresis, and repeatability.

2) Defined as ±2 standard deviation limits. See also calibration certificate.

Inputs and outputs

Operating voltage	Digital output: 15 ... 30 V DC Analog output: 15 ... 25 V DC
Current consumption at +25 °C (+77 °F)	
In digital mode	Max. 10 mA
In analog mode	Max. 50 mA
During sensor purge	Max. 250 mA
Digital output	
Interface	RS-485, not isolated; do not use termination on the RS-485 line
Communication protocol	Modbus RTU v1.02
Analog output	
Outputs	2 × 4 ... 20 mA 3-wire current outputs
Max. load	500 Ω
Accuracy (typical)	±0.1 % of full scale
Analog output temperature dependence	0.005 %/°C (0.003 %/°F) full scale dependence

Operating environment

Operating temperature	+0 ... +70 °C (+32 ... +158 °F)
Storage temperature	-20 ... +70 °C (-4 ... +158 °F)
Ambient pressure	Normal atmospheric pressure
IP rating	IP65

Compliance

EU directives and regulations	EMC, RoHS
Electromagnetic compatibility (EMC)	EN 61326-1, industrial environment
EMC emissions	CISPR 32 / EN 55032, Class B
Compliance marks	CE, China RoHS, RCM

Mechanical specifications

Connector	M12-5M
Materials	
Probe body	AISI316L stainless steel
Filter cap	Porous PTFE

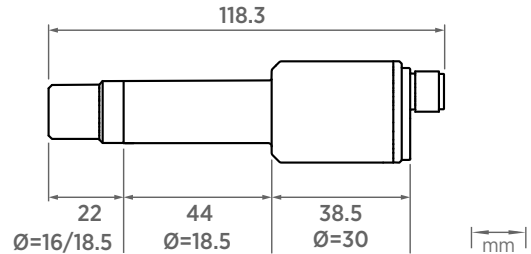

HPP271 dimensions

Spare parts and accessories

Indigo USB adapter ¹⁾	USB2
Probe connection cable with open wires, 1.5 m (4.9 ft)	254294SP
Probe connection cable with open wires, 3 m (9.8 ft)	254295SP
Probe connection cable with open wires, 5 m (16 ft)	254296SP
Probe connection cable with open wires, 10 m (33 ft)	254297SP
Flat cable, M12-5F - M12-5M, 1 m (3.3 ft)	CBL210493SP
Filter	DRW246363SP
Gland set for through-wall installation, HPP271	HPP271MOUNTINGSET1
Flange for through-wall installation, HPP271	HPP271MOUNTINGSET2
Wall mount for HPP271 and HPP272	HPP272WALLMOUNT
Indigo transmitters	See www.vaisala.com/indigo
Indigo80 handheld indicator	See www.vaisala.com/indigo80

1) Vaisala Insight software for Windows available at www.vaisala.com/insight.

HPP272 technical data

Measurement performance

Hydrogen peroxide	
Sensor	PEROXCAP®
Measurement range	0 ... 2000 ppm
Measurement temperature range	+5 ... +50 °C (+41 ... +122 °F)
Repeatability at +25 °C (+77 °F) up to 500 ppm H ₂ O ₂	±10 ppm
Accuracy at +10 ... +25 °C (+50 ... +77 °F), 10 ... 2000 ppm H ₂ O ₂ ¹⁾	±10 ppm or 5 % of reading (whichever is greater)
Factory calibration uncertainty at +25 °C (+77 °F), 500 ppm H ₂ O ₂ ²⁾	±10 ppm
Response time (T ₆₃)	70 s
Relative saturation	
Measurement range	0 ... 100 %RS
Measurement temperature range	+5 ... +50 °C (+41 ... +122 °F)
Repeatability at +25 °C (+77 °F), 500 ppm H ₂ O ₂	±0.5 %RS
Accuracy at +25 °C (+77 °F) ¹⁾	±4 %RS
Factory calibration uncertainty at +25 °C (+77 °F), 500 ppm H ₂ O ₂ ²⁾	±2 %RS
Relative humidity	
Measurement range	0 ... 100 %RH
Measurement temperature range	+5 ... +70 °C (+41 ... +158 °F)
Accuracy: ¹⁾	
at +25 °C (77 °F), 0 ppm H ₂ O ₂ , 0 ... 90 %RH	±1 %RH
over full temperature measurement and H ₂ O ₂ range	±2 %RH
Response time (T ₆₃)	20 s
Factory calibration uncertainty at +25 °C (77 °F), 0 ppm H ₂ O ₂ , 0 ... 95 %RH ²⁾	±1 %RH
Temperature	
Sensor	Pt1000 RTD Class F0.1
Accuracy over temperature range	±0.2 °C (±0.36 °F)
Other parameters	
Absolute H ₂ O ₂ and H ₂ O, H ₂ O ppm by volume, water vapor saturation pressure (H ₂ O and H ₂ O+H ₂ O ₂), dew point temperature, vapor pressure (H ₂ O and H ₂ O ₂)	

1) Including non-linearity, hysteresis, and repeatability.
2) Defined as ±2 standard deviation limits. See also calibration certificate.

Inputs and outputs

Operating voltage	Digital output: 15 ... 30 V DC Analog output: 15 ... 25 V DC
Current consumption at +25 °C (+77 °F)	
In digital mode	Max. 10 mA
In analog mode	Max. 50 mA
During sensor purge	Max. 250 mA
Digital output	
Interface	RS-485, not isolated; do not use termination on the RS-485 line
Communication protocol	Modbus RTU v.1.02
Analog output	
Outputs	2 × 4 ... 20 mA 3-wire current outputs
Max. load	500 Ω
Accuracy (typical)	±0.1 % of full scale
Analog output temperature dependence	0.005 %/°C (0.003 %/°F) full scale

Operating environment

Operating temperature	+0 ... +70 °C (+32 ... +158 °F)
Storage temperature	-20 ... +70 °C (-4 ... +158 °F)
Ambient pressure	Normal atmospheric pressure
IP rating	IP65

Compliance

EU directives and regulations	EMC, RoHS
Electromagnetic compatibility (EMC)	EN 61326-1, industrial environment
EMC emissions	CISPR 32 / EN 55032, Class B
Compliance marks	CE, China RoHS, RCM

Mechanical specifications

Connector	M12-5M
Materials	
Probe body	AISI316L stainless steel
Filter cap	Porous PTFE
Temperature probe	AISI316L stainless steel
Temperature probe cable	PTFE

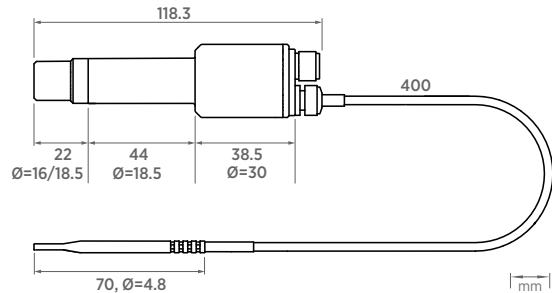

HPP272 dimensions

Spare parts and accessories

Indigo USB adapter ¹⁾	USB2
Probe connection cable with open wires, 1.5 m (4.9 ft)	254294SP
Probe connection cable with open wires, 3 m (9.8 ft)	254295SP
Probe connection cable with open wires, 5 m (16 ft)	254296SP
Probe connection cable with open wires, 10 m (33 ft)	254297SP
Flat cable, M12-5F - M12-5M, 1 m (3.3 ft)	CBL210493SP
Filter	DRW246363SP
Gland set for through-wall installation, HPP272	HPP272MOUNTINGSET1
Flange for through-wall installation, HPP272	HPP272MOUNTINGSET2
Wall mount for HPP271 and HPP272	HPP272WALLMOUNT
Indigo transmitters	See www.vaisala.com/indigo
Indigo80 handheld indicator	See www.vaisala.com/indigo80

1) Vaisala Insight software for Windows available at www.vaisala.com/insight.

HPP271 and HPP272 installation accessories

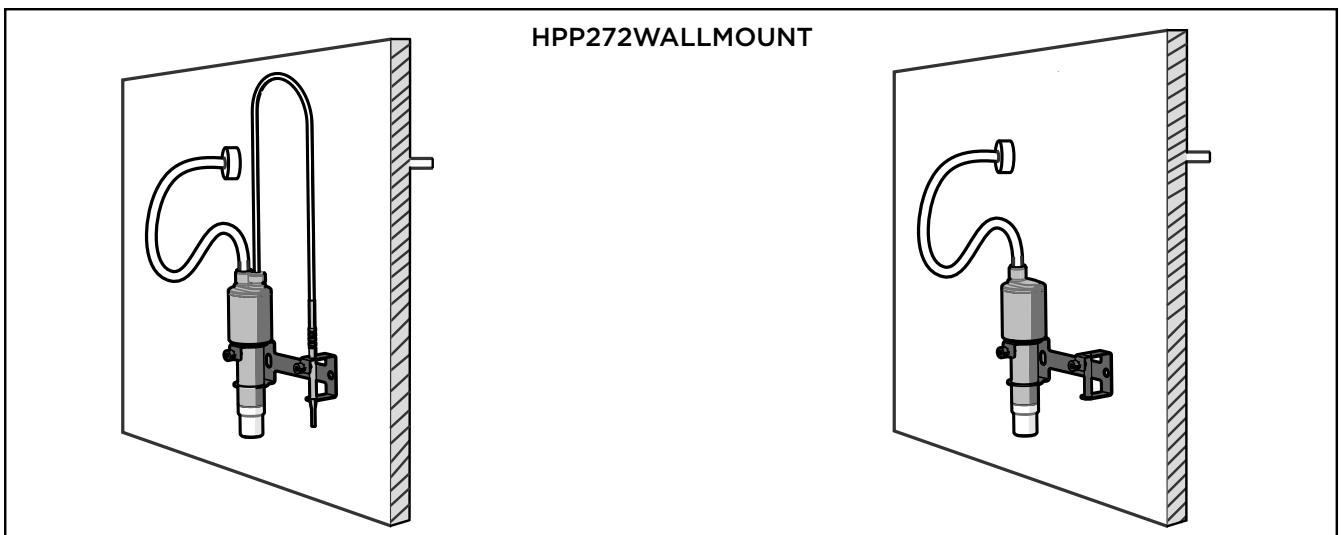
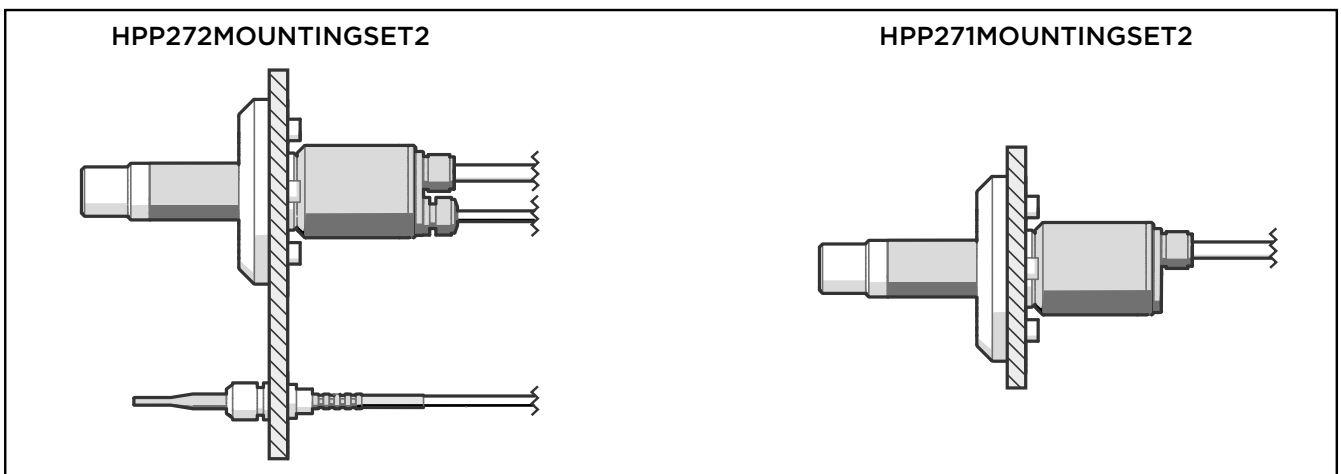
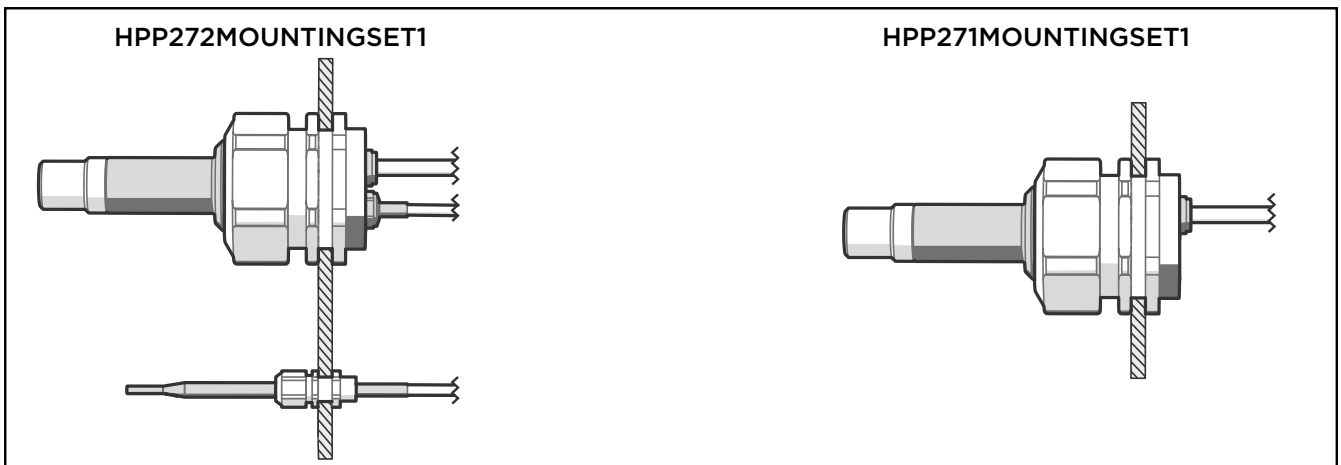

Indigo80 Handheld Indicator For portable diagnostics









Features

- Flexible operation with Vaisala Indigo family measurement probes and other supported Vaisala devices
- Complemented by the HMP80 and DMP80 handheld probes and the GMP80P probe with pump sampling, which are optimized for portable use cases
- Intuitive user interface available in 10 languages
- Rechargeable battery
- Robust design and modern appearance
- Logged measurement data can be transferred to PC via Vaisala Insight software

Vaisala Indigo80 Handheld Indicator is an industrial-grade portable diagnostics tool. Accommodating up to two Vaisala devices, Indigo80 is ideal for spot-checking and process monitoring, as well as for configuring, troubleshooting, calibrating, and adjusting Indigo family measurement probes and other supported Vaisala devices.

Seamless compatibility for varied measurements

The Indigo80 indicator has two cable ports by which a combination of two compatible measurement devices can be simultaneously connected to the indicator. Indigo80 can communicate with most current and future Vaisala devices for measuring a wide range of parameters.

-  Humidity and temperature
-  Dew point
-  Carbon dioxide
-  Hydrogen peroxide vapor
-  Moisture in oil
-  Liquid concentration

For the full set of Vaisala devices currently compatible with Indigo80, see the following page. For more information on the Indigo product family, see vaisala.com/indigo.

Robust and reliable

The sturdy aluminum body of Indigo80 is resistant to chemicals and dust.

Indigo80 is powered by a rechargeable lithium-ion battery with a typical operation time of 10 h. During long-term logging Indigo80 can be powered by using an AC adapter.

Easy to use

Indigo80 has an intuitive user interface that guides the user if needed. The indicator is designed to be easy to use in numerous use cases and measurement environments.

To access logged data and configuration functionality, Indigo80 can be connected to Vaisala Insight PC software for Windows®. For more information, see vaisala.com/insight.

Multilingual user interface

Indigo80 has a multilingual, menu-based user interface that shows live measurement data both numerically and graphically. The Indigo80 user interface is available in 10 languages.

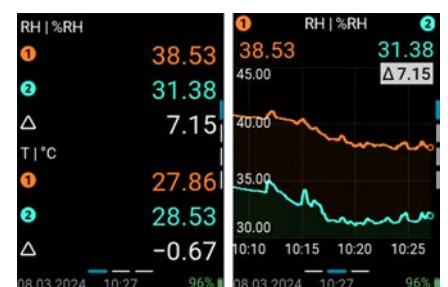

View live measurement data as numbers or graphs

Vaisala devices compatible with Indigo80

Vaisala devices with older firmware versions may have limited compatibility with the Indigo80 indicator. For the most up-to-date version compatibility information, see [Firmware version compatibility of Indigo80-compatible devices Technical Note \(M212901EN\)](#), available at docs.vaisala.com.

Vaisala Indigo-compatible probes

HMP1, HMP3, HMP4, HMP5, HMP7, HMP8, HMP9, HMP80L, HMP80N	Humidity and temperature
TMP1	Temperature
DMP5, DMP6, DMP7, DMP8, DMP80A, DMP80B	Dew point
GMP251, GMP252	Carbon dioxide
HPP271, HPP272	Vaporized hydrogen peroxide
MMP8	Moisture in oil

Vaisala Indigo transmitters (host devices)

Indigo300, Indigo510, Indigo520

Other Vaisala devices

HMP60, HMP63, HMP110, HMP113, HMP115 probes HMM170 module	Humidity and temperature
HMP110T, HMP115T, TMP115 probes	Temperature
DMT143, DMT143L transmitters	Dew point
GMW90 and HMW90 series transmitters	Humidity, temperature, and carbon dioxide
MGP241 probe	Carbon dioxide
HMT370EX series transmitters	Humidity and temperature
PR53 series refractometers	Liquid concentration

Technical data

Operating environment

Operating temperature	-20 ... +50 °C (-4 ... +122 °F)
Storage temperature	-20 ... +60 °C (-4 ... +140 °F), recommended +20 °C (+68 °F)
Operating and storage humidity	20–85 %RH, when Ta ≤ +40 °C (+104 °F)
Charging temperature	0 ... +45 °C (+32 ... +113 °F) ¹⁾
IP rating	IP40
Use in wet location	No
Operating environment	Indoor use
Pollution degree	3
Maximum operating altitude	2000 m (approx. 6500 ft)

¹⁾ The battery will not charge at temperatures below 0 °C (+32 °F).

Data logging and user interface specifications

Data logging capacity	Up to 5.5 million real-time data values
Logging interval	1 s - 12 h
Logging duration	1 min - memory full ¹⁾
Alarm	Audible alarm function
Supported languages	English, Chinese, Finnish, French, German, Italian, Japanese, Portuguese, Spanish, Swedish
Display	2.7" sunlight readable transfective TFT LCD color display with backlight and automatic brightness control

¹⁾ For example, data logging duration for one measurement parameter with a logging interval of one second is over eight weeks. Use an AC adapter to power Indigo80 during long-term logging.

Battery operation time

Operation time (continuous use)	10 h at +20 °C (+68 °F) ¹⁾
Charging time	2 hours ¹⁾

¹⁾ Typical value. Actual performance depends on, for example, the number and type of devices connected to Indigo80 and the data logging interval.

Mechanical specifications

Weight	385 g (14 oz)
Dimensions (H × W × D)	213 × 58 × 27 mm (8.4 × 2.3 × 1.1 in)
Materials	
Main body and rear piece	Aluminum EN AW-6082 T6
Back cover	Rubber (TPE) and polycarbonate (PC), reinforced with fiberglass Flammability rating UL94 V-1
Display	Strengthened glass with anti-fingerprint (AF) and anti-reflection (AR) coatings

Compliance

EU directives and regulations	EMC Directive (2014/30/EU) RoHS Directive (2011/65/EU) as amended by 2015/863
Electromagnetic compatibility (EMC)	IEC/EN 61326-1, industrial environment CISPR 32 / EN 55032, Class B FCC part 15 B, Class B ICES-3 / NMB-3 (Class B)
Electrical safety	IEC/EN 61010-1
Compliance marks	CE, China RoHS, FCC, RCM, UKCA

Inputs and outputs

Max. number of connected devices	2
Connector type	M12 5-pin female (2 pcs)
Battery ¹⁾	
Type	Rechargeable lithium-ion battery
Nominal voltage	7.2 V
Rated capacity	2900 mAh / 20.88 Wh
Charge limit voltage	8.4 V
AC adapter ²⁾	
Type	45 W USB-C AC adapter ³⁾
Connector type	USB-C
AC input	100-240 V AC, 1.2 A, 50-60 Hz
DC output	5.0 V/9.0 V/12.0 V/15.0 V DC, 3.0 A 20.0 V DC, 2.25 A 45 W
Insulation	Double or reinforced, indicated with the following symbol: 
PC interface	Vaisala Insight PC software with USB-C cable (Windows OS). ⁴⁾ Data can be logged and transferred also without Insight.

¹⁾ The battery is not user-replaceable. Contact Vaisala Service Center for any battery-related maintenance needs.

²⁾ The AC adapter is an optional accessory. If using an AC adapter not provided by Vaisala, make sure it fulfills the specifications given in this table and the safety requirements listed in Indigo80 Safety Guide (M212872EN), available at docs.vaisala.com.

³⁾ 45 W AC adapter recommended for optimal performance of Indigo80. An AC adapter with a lower power rating can also be used.

⁴⁾ Insight software is available for download at vaisala.com/insight.

Spare parts and accessories

Cables	
Cable for transmitters (M12-M8), 1.5 m (4 ft 11 in)	262195SP
Cable for probes (M12-M12), 1.5 m (4 ft 11 in)	272075SP
Flat cable for probes (M12-M12), 1 m (3 ft 3 in)	CBL210493SP
Probe connection cable (M12-M12), 10 m (32 ft 10 in)	INDIGOCABLE10M
Other	
Magnetic hanger for indicator	ASM214318SP
Weatherproof carrying case for Indigo80 and HMP80 and DMP80 series probes	ASM214759
Weatherproof carrying case for Indigo80 and a series 8 probe ¹⁾	ASM215318
Light carrying case for HM40S or Indigo80 indicator and a compatible probe ²⁾	230245SP

¹⁾ For example, MMP8, HMP8, or DMP8 with a max. 2-m (6 ft 7 in) probe connection cable.

²⁾ For example, DMP80, HMP80N, or GMP252 probe with handle accessory and a max. 1.5-m (4 ft 11 in) probe connection cable.

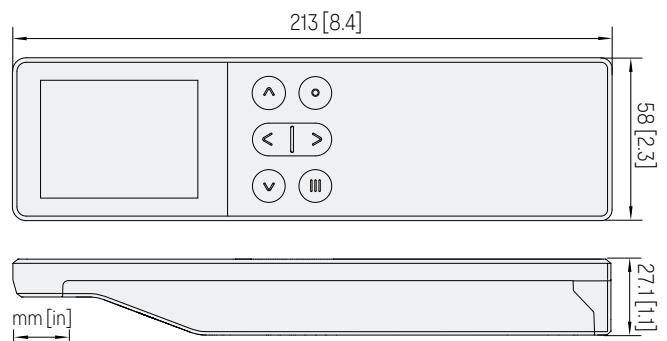

Indigo80 dimensions (front and side view)

HMP80 Series Handheld Humidity and Temperature Probes

For spot-checking applications



Features

- Portable design optimized for industrial spot-checking and field calibration
- RH accuracy up to ± 0.8 %RH
- Temperature accuracy up to 0.1 °C (0.18 °F)
- Wide temperature measurement range
- Condensation-tolerant
- Sensor purge improves long-term stability and chemical resistance
- Compatible with Indigo80 handheld indicator and Insight PC software
- Calibration certificate included

Vaisala HUMICAP® Handheld Humidity and Temperature Probes HMP80 Series have been designed for portable use, especially with the Indigo80 handheld indicator. The combination of HMP80 probe and Indigo80 is ideal for spot-checking and field calibration of installed Vaisala humidity instruments.

Proven Vaisala HUMICAP performance

Vaisala is the original innovator of the thin-film capacitive humidity measurement technology, which has now become the industry standard in humidity measurement.

The HUMICAP technology results from Vaisala's 40-year experience in industrial humidity measurement, providing the best stability, fast response time, and low hysteresis in a wide range of applications.

HMP80 series probes are delivered with standard factory calibration certificates, with accredited calibration as an option. The probes can therefore be used as a working standard in field calibration.

Robust design for handheld measurements

The HMP80 series probes are available in two lengths offering similar measurement performance. The longer model (HMP80L) is designed for measurements in more extreme temperatures.

The design of the probe handle has been optimized for manual operation in versatile measurement environments. The IP66-classified probe handle offers excellent protection against moisture and dust with the probe connection cable attached. Also the cable connection is protected against mechanical stress by the robust design of the handle.

Flexible connectivity

HMP80 probes are optimized for portable spot-checking, field calibration, and data logging use with the Indigo80 handheld indicator. For easy-to-use access to device analytics and configuration, HMP80 probes can be connected to Vaisala Insight software for Windows®.

For more information, see www.vaisala.com/indigo and www.vaisala.com/insight.

Technical data

HMP80 series measurement performance

Relative humidity	
Measurement range	0-100 %RH
Accuracy at +23 °C (73.4 °F) ¹⁾	±0.8 %RH (0-90 %RH)
Factory calibration uncertainty ²⁾	±0.5 %RH (0-40 %RH)
	±0.8 %RH (40-95 %RH)
T ₆₃ response time	15 s
Sensor	HUMICAP® R2C
Temperature	
Measurement range	HMP80N: -20 ... +60 °C (-4 ... +140 °F) HMP80L: -50 ... +120 °C (-58 ... +248 °F), short-time measurement range -50 ... +180 °C (-58 ... +356 °F)
Accuracy at +23 °C (+73.4 °F) ^{1) 3)}	±0.1 °C (±0.18 °F)
Factory calibration uncertainty ²⁾	±0.1 °C (±0.18 °F) at +23 °C (+73.4 °F)
Sensor	Pt100 RTD Class FO.1 IEC 60751

- 1) Defined against calibration reference. Including non-linearity, hysteresis, and repeatability.
 2) Defined as ±2 standard deviation limits. Small variations possible; see calibration certificate.
 3) Exposing temperature sensor to temperatures below -20 °C (-4 °F) may cause permanent additional deviation of ±0.1 °C (0.18 °F).

HMP80 series operating environment

Operating temperature of probe handle	-10 ... +60 °C (-14 ... +140 °F)
Operating temperature of probe head	HMP80N: -20 ... +60 °C (-4 ... +140 °F)
	HMP80L: -50 ... +120 °C (-58 ... +248 °F)
Storage temperature	-20 ... +60 °C (-4 ... +140 °F)
Measurement environment	For air, nitrogen, hydrogen, argon, helium, oxygen, and vacuum ¹⁾
IP rating of probe handle:	
with probe connection cable connected to the probe	IP66
without cable	IP55

¹⁾ Consult Vaisala if other chemicals are present. Consider safety regulations with flammable gases.

HMP80 series inputs and outputs

Operating voltage	15-30 V DC
Current consumption	10 mA typical, 500 mA max.
Digital output	RS-485, non-isolated

HMP80 series compliance

EU directives and regulations	EMC Directive (2014/30/EU) RoHS Directive (2011/65/EU) as amended by 2015/863
Electromagnetic compatibility (EMC)	EN 61326-1, industrial environment
Rough handling (excluding sensor inside probe head)	IEC 60068-2-31
Compliance marks	CE, China RoHS, RCM, UKCA

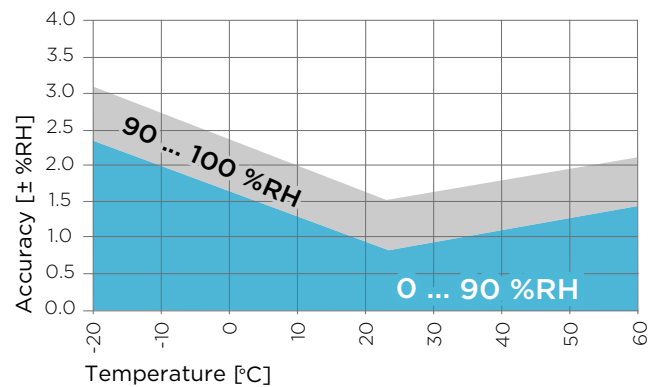

HMP80N humidity measurement accuracy as a function of temperature

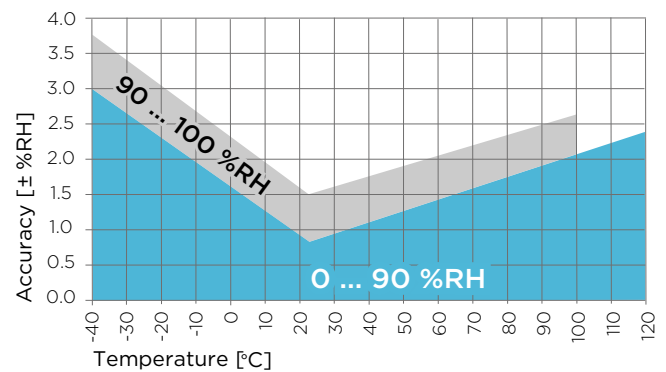

HMP80L humidity measurement accuracy as a function of temperature

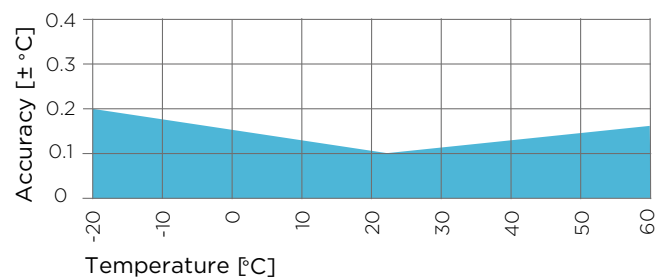

HMP80N temperature measurement accuracy over full range

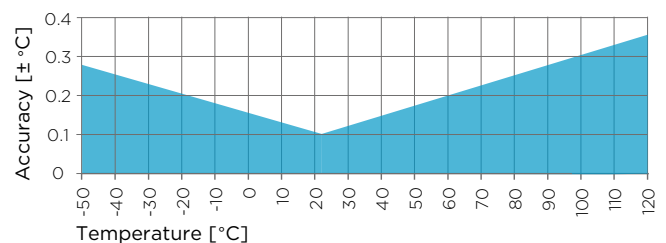

HMP80L temperature measurement accuracy over full range

HMP80 series output parameters

Absolute humidity (g/m ³)	Relative humidity (%RH)
Absolute humidity at NTP (g/m ³)	Relative humidity (dew/frost) (%RH)
Dew point temperature (°C)	Temperature (°C)
Dew/frost point temperature (°C)	Water concentration (ppm _w)
Dew/frost point temperature at 1 atm (°C)	Water concentration (wet basis) (vol-%)
Dew point temperature at 1 atm (°C)	Water mass fraction (ppm _w)
Dew point temperature difference (°C)	Water vapor pressure (hPa)
Enthalpy (kJ/kg)	Water vapor saturation pressure (hPa)
Mixing ratio (g/kg)	Wet-bulb temperature (°C)

HMP80 series mechanical specifications

Connector type	M12 5-pin A-coded male
Weight	HMP80N: 200 g (7 oz) HMP80L: 300 g (10 oz)
Materials	
Probe handle	Polyamide (PA) and thermoplastic elastomer (TPE)
Probe shaft	Stainless steel (AISI 316L)
Filters	HMP80N: Stainless steel (AISI 316L) ¹⁾ HMP80L: Porous stainless steel (AISI 316L) ²⁾

1) With holes and without an additional filter membrane. Vaisala item code of filter: DRW255306SP.
2) Vaisala item code: HM47280SP

HMP80 series spare parts and accessories

Probe connection cable (M12-M12), 1.5 m (4.11 ft)	272075SP
Flat cable for probes (M12-M12), 1.0 m (3.4 ft)	CBL210493SP
Indigo USB adapter	USB2
Sintered stainless steel filter (HMP80N, HMP80L)	HM47280SP
Plastic PPS grid filter (HMP80N, HMP80L)	DRW010276SP
PPS grid with SS netting (HMP80N, HMP80L)	DRW010281SP
Slotted MIM filter (HMP80N)	DRW255306SP
Slotted MIM filter with membrane (HMP80N)	ASM214606SP

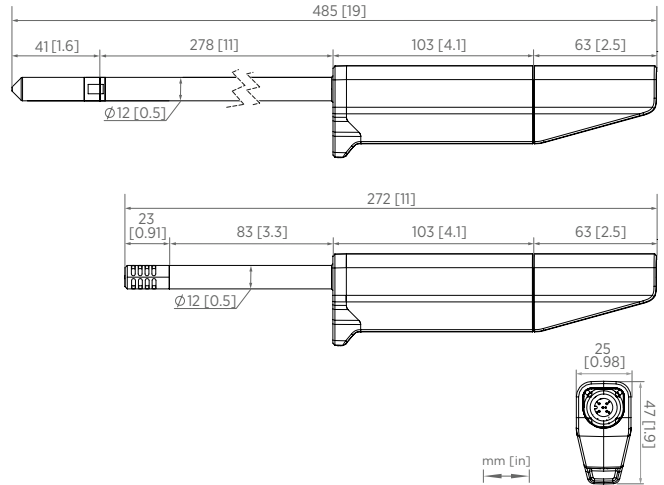

Dimensions of HMP80L (top) and HMP80N (bottom), side and bottom view

DMP80 Series Handheld Dew Point and Temperature Probes

For spot-checking applications



Features

- Portable design optimized for industrial spot-checking and field calibration
- Dew point measurement accuracy up to ± 2 °C (± 3.6 °F) $T_{d/f}$
- Wide dew point measurement range
- Sensor purge improves long-term stability and chemical resistance
- Condensation-tolerant
- Compatible with Indigo80 handheld indicator and Insight PC software
- Calibration certificate included

Vaisala DRYCAP® Handheld Dew Point and Temperature Probes DMP80 Series have been designed for portable use, especially with the Indigo80 handheld indicator. The combination of DMP80 probe and Indigo80 is ideal for spot-checking and field calibration of installed Vaisala humidity instruments.

Reliable measurements with the Vaisala DRYCAP sensor

Vaisala DRYCAP sensor is robust against particulate contamination, water condensation, oil vapor, and most chemicals. The sensor tolerates condensation and recovers perfectly if exposed to liquid water. The sensor's performance is excellent also in dynamic and low dew point applications, thanks to its fast reaction time and stability.

The probes can be inserted directly into pressurized processes, and respond rapidly from ambient to process conditions. The DMP80 probes are suitable for direct process dew point measurement in a wide temperature and pressure range.

DMP80 series probes are delivered with standard factory calibration certificates, with accredited calibration as an option. The probes can therefore be used as a working standard in field calibration.

Sensor purge minimizes effects of contaminants

In environments with high concentrations of chemicals and cleaning agents, the sensor purge option helps to maintain measurement accuracy between calibration intervals.

Sensor purge involves heating the sensor briefly to remove chemicals that could lower measurement performance and cause drifting.

Robust design for handheld measurements

The design of the probe handle has been optimized for manual operation in versatile measurement environments. The IP66-classified probe handle offers excellent protection against moisture and dust with the probe connection

cable attached. Also the cable connection is protected against mechanical stress by the robust design of the handle.

Flexible connectivity

DMP80 probes are optimized for portable spot-checking, field calibration, and data logging use with the Indigo80 handheld indicator. For easy-to-use access to device analytics and configuration, DMP80 probes can be connected to Vaisala Insight software for Windows®.

For more information, see www.vaisala.com/indigo and www.vaisala.com/insight.

Technical data

DMP80A measurement performance

Dew point	
Sensor	DRYCAP® 180S
Measurement range	-40 ... +60 °C (-40 ... +140 °F) T _{d/f}
Accuracy	Up to ±2 °C (±3.6 °F) T _{d/f}
Response time 63 % [90 %]:	
From dry to wet	5 s [10 s]
From wet to dry	45 s [5 min]
Temperature	
Measurement range	0 ... +60 °C (+32 ... +140 °F)
Accuracy	±0.2 °C (±0.36 °F) at room temperature
Temperature sensor	Pt100 RTD Class F0.1 IEC 60751
Mixing ratio	
Measurement range (typical)	0-150 g/kg (0-1050 gr/lbs)
Accuracy (typical)	±12 % of reading
Absolute humidity	
Measurement range	0-130 g/m ³
Accuracy (typical)	±10 % of reading

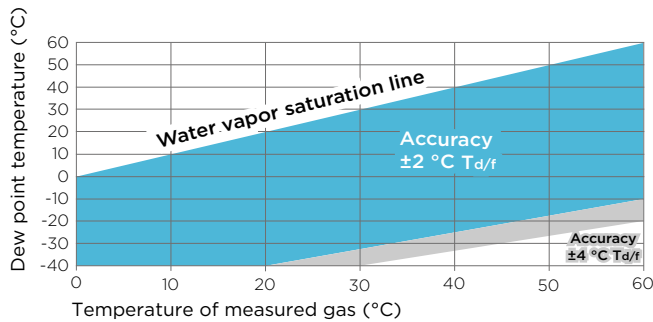

Dew point accuracy vs. measurement conditions (DMP80A)

DMP80 series operating environment

Operating temperature range	-10 ... +60 °C (+14 ... +140 °F)
Storage temperature	-20 ... +60 °C (-4 ... +140 °F)
Operating pressure of probe head	0-20 bar (0-290 psi), absolute
Measurement environment	For air, nitrogen, hydrogen, argon, helium, and oxygen ¹⁾
IP rating of probe handle:	
With probe connection cable connected to the probe	IP66
Without cable	IP55

¹⁾ Consult Vaisala if other chemicals are present. Consider safety regulations with flammable gases.

DMP80 series inputs and outputs

Operating voltage	15-30 V DC
Current consumption	10 mA typical, 500 mA max.
Digital output	RS-485, non-isolated

DMP80B measurement performance

Dew point	
Sensor	DRYCAP® 180M
Measurement range	-70 ... +60 °C (-94 ... +140 °F) T _{d/f}
Accuracy	Up to ±2 °C (±3.6 °F) T _{d/f}
Response time 63 % [90 %]:	
From dry to wet	5 s [15 s]
From wet to dry	45 s [8 min]
Temperature	
Measurement range	0 ... +60 °C (+32 ... +140 °F)
Accuracy	±0.2 °C (±0.36 °F) at room temperature
Temperature sensor	Pt100 RTD Class F0.1 IEC 60751
Relative humidity	
Measurement range	0-70 %RH
Accuracy (RH <10 %RH, at +20 °C)	±0.004 %RH + 20 % of reading
Concentration by volume (ppm)	
Measurement range (typical)	10-2500 ppm
Accuracy (at +20 °C, 1 bar)	1 ppm + 20 % of reading

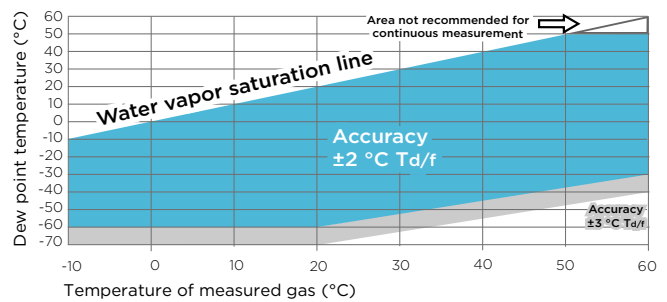

Dew point accuracy vs. measurement conditions (DMP80B)

DMP80 series mechanical specifications

Connector type	M12 5-pin A-coded male
Weight	250 g (9 oz)
Mechanical connection options	G1/2" ISO 228/1 NPT1/2"
Materials	
Probe handle	Polyamide (PA) and thermoplastic elastomer (TPE)
Probe shaft	Stainless steel (AISI 316L)
Filter	Porous stainless steel (AISI 316L) ¹⁾

¹⁾ Vaisala item code: HM47280SP

DMP80 series output parameters

Absolute humidity (g/m ³)	Relative humidity (%RH)
Absolute humidity at NTP (g/m ³)	Relative humidity (dew/frost) (%RH)
Dew point temperature (°C)	Temperature (°C)
Dew/frost point temperature (°C)	Water concentration (ppm _v)
Dew/frost point temperature at 1 atm (°C)	Water concentration (wet basis) (vol-%)
Dew point temperature at 1 atm (°C)	Water mass fraction (ppm _w)
Dew point temperature difference (°C)	Water vapor pressure (hPa)
Enthalpy (kJ/kg)	Water vapor saturation pressure (hPa)
Mixing ratio (g/kg)	

DMP80 series compliance

EU directives and regulations	EMC Directive (2014/30/EU) RoHS Directive (2011/65/EU) as amended by 2015/863
Electromagnetic compatibility (EMC)	EN 61326-1, industrial environment
Rough handling (excluding sensor inside probe head)	IEC 60068-2-31
Compliance marks	CE, China RoHS, RCM, UKCA

DMP80 series spare parts and accessories

Cables	
Probe connection cable (M12-M12), 1.5 m (4.11 ft)	272075SP
Flat cable for probes (M12-M12), 1.0 m (3.4 ft)	CBL210493SP
Accessories for ISO G1/2" thread option	
Sampling cell with quick connector and leak screw	DSC74
Sampling cell with female connectors, inlet G3/8", outlet G1/4" ISO	DMT242SC
Sampling cell with Swagelok connectors for 1/4" tubing	DMT242SC2
Two-pressure sampling cell	DSC74B
Two-pressure sampling cell with coil	DSC74C
Other items	
Indigo USB adapter	USB2
Sintered stainless steel filter	HM47280SP

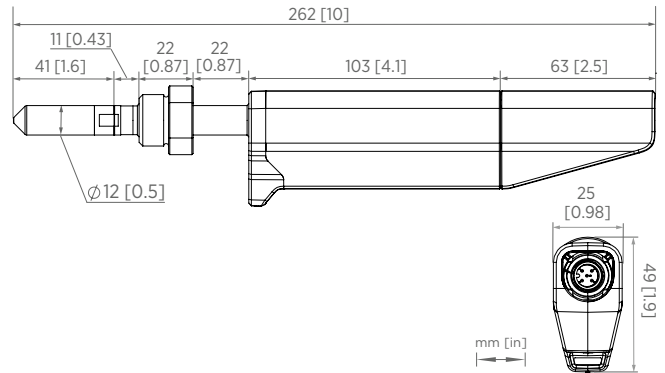

Dimensions of DMP80 series probes with G1/2" thread, side and bottom view

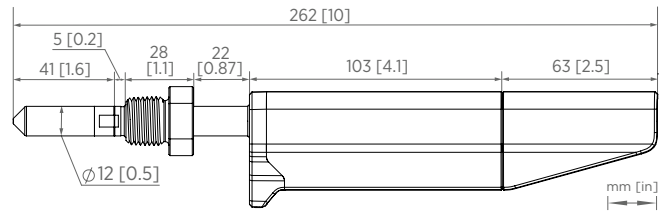

Dimensions of DMP80 series probes with NPT1/2" thread



Features

- Humidity measurement range 0 ... 100 %RH
- Temperature measurement ranges -40 ... +100 °C (-40 ... +212 °F), depending on probe model. The HM46 model can measure up to +180 °C (+356 °F) for a short period of time.
- Incorporates proven Vaisala HUMICAP® sensor technology
- Calibration reminder function
- Probes can be user calibrated using an on-site reference
- Graphical display indicates when measurement has stabilized
- Hold-button to freeze the screen and save the reading
- Multilingual user interface available in 10 languages (EN, DE, FR, JA, ZH, PT, ES, RU, FI, SV)

The easy-to-use HM40 is a compact and portable humidity meter that provides reliable measurements in a wide range of applications. It is the ideal spot-checking tool for everything from structural moisture measurement and air conditioning systems to humidity measurement in industrial production processes and life science applications. There are four different models available: HM41, HM42, HM45, and HM46.

Benefits

- Compact, portable, and easy to use
- Versatile meter with wide measurement range and multiple calculated parameters
- Ideal for spot-checking in a wide variety of applications

Simple and Easy to Use

HM40 has a large, user-friendly graphical display and easy-to-use push buttons. The user interface is simple and intuitive, and available in 10 languages. Also, many settings can be modified to meet users' individual needs. In addition to relative humidity and temperature, HM40 provides five calculated humidity

parameters, all of which are available in metric and non-metric units. HM40 is powered by 2 AA batteries. An external USB-charger and rechargeable AA sized NiMH batteries are available as an option. Each model also comes with a handy belt clip and case.

Easy Recalibration

Calibrating HM40 is easy. The meter or the probe can be sent to a Vaisala Service Center for recalibration. Alternatively, calibration can be completed on site by users with a humidity reference such as another hand-held meter or Vaisala Humidity Calibrator HMK15. The indicator includes a calibration reminder function that can be activated by the user.

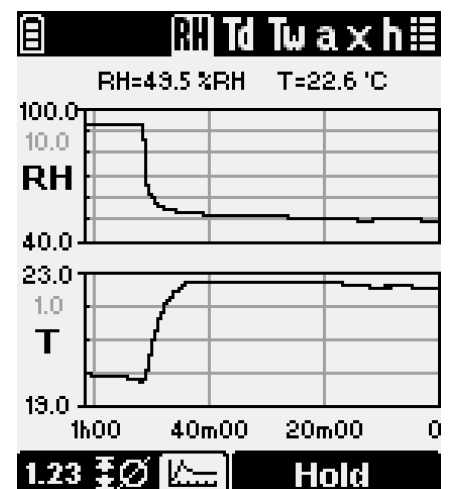

The Graph Clearly Indicates When Readings Have Stabilized.

HM40 Handheld Humidity and Temperature Meter Series



HM41 Technical Data

Humidity Measurement Accuracy (Including Non-linearity, Hysteresis, and Repeatability):

At 0 ... +40 °C	±1.5 %RH (0 ... 90 %RH)
	±2.5 %RH (90 ... 100 %RH)
At -10 ... 0 °C and +40 ... +60 °C	±3.0 %RH (0 ... 90 %RH)
	±4.0 %RH (90 ... 100 %RH)

Humidity sensor	HUMICAP® 180R
Temperature measurement range	-10 ... +60 °C (+14 ... +140 °F)
Temperature sensor	Pt1000 RTD Class F0.1 IEC 60751
Measurement probe	Interchangeable HMP113 probe
Probe material	PC/ABS plastic blend (white)
IP rating	IP54
Weight (with alkaline batteries)	230 g (8.1 oz)
Filter material	PC (glass-reinforced)

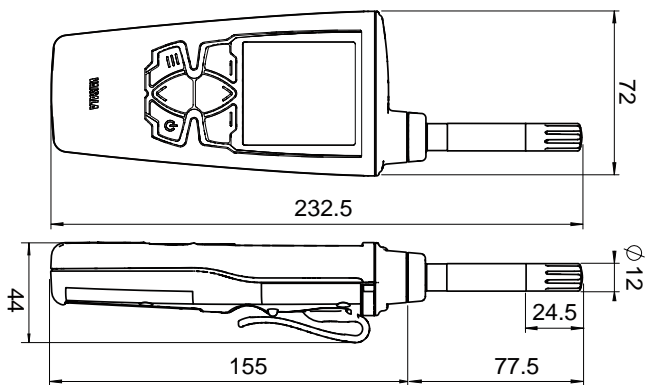

HM41 dimensions in mm



HM42 Technical Data

Humidity Measurement Accuracy (Including Non-linearity, Hysteresis, and Repeatability):

At 0 ... +40 °C	±1.5 %RH (0 ... 90 %RH)
	±2.5 %RH (90 ... 100 %RH)
At -40 ... 0 °C and +40 ... +80 °C	±3.0 %RH (0 ... 90 %RH)
	±4.0 %RH (90 ... 100 %RH)
At +80 ... +100 °C	±4.0 %RH ¹⁾

Humidity sensor	HUMICAP® 100R-Mini
Temperature measurement range	-40 ... +100 °C (-40 ... +212 °F)
Temperature sensor	Pt1000 RTD Class F0.3 IEC60751
Measurement probe	HM42PROBE
Probe head material	Stainless steel
IP rating	IP40 (probe), IP54 (indicator)
Weight (with alkaline batteries)	370 g (13.1 oz)
Filter material	Stainless steel and PTFE membrane
Probe cable length	1500 mm (59 in)

¹⁾ Not recommended for $T_d > 85 °C$

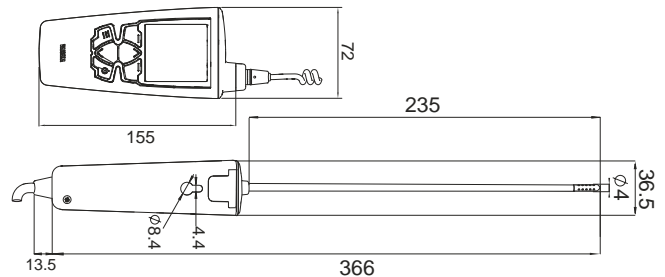

HM42 dimensions in mm



HM45 Technical Data

Humidity Measurement Accuracy (Including Non-linearity, Hysteresis, and Repeatability):

At 0 ... +40 °C	±1.5 %RH (0 ... 90 %RH)
	±2.5 %RH (90 ... 100 %RH)
At -40 ... 0 °C and +40 ... +60 °C	±3.0 %RH (0 ... 90 %RH)
	±4.0 %RH (90 ... 100 %RH)

Humidity sensor	HUMICAP® 180R
Temperature measurement range	-40 ... +60 °C (-40 ... +140 °F)
Temperature sensor	Pt1000 RTD Class F0.1 IEC 60751
Measurement probe	Interchangeable HMP113 with HM40HANDLE
Probe material	PC/ABS plastic blend (white)
IP rating	IP54
Weight (with alkaline batteries)	330 g (11.6 oz)
Filter material	PC (glass-reinforced)
Probe cable length	1200 mm (47 in)

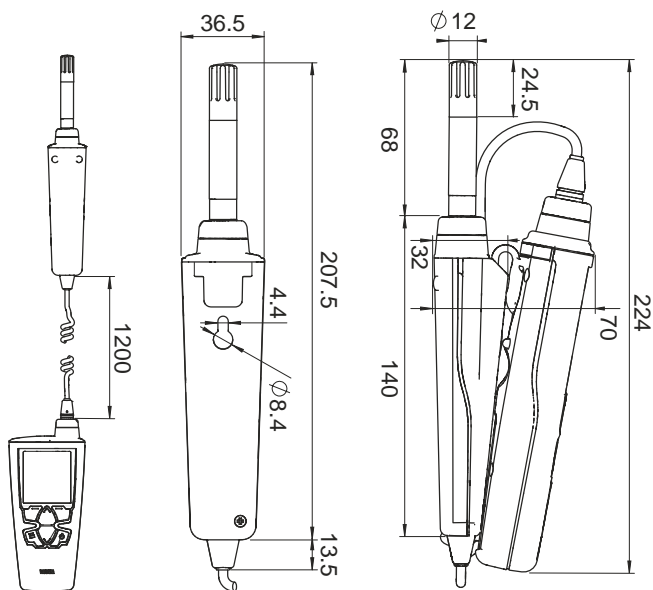

HM45 dimensions in mm

HM46 Technical Data

Humidity Measurement Accuracy (Including Non-linearity, Hysteresis, and Repeatability):

At 0 ... +40 °C	±1.5 %RH (0 ... 90 %RH)
	±2.5 %RH (90 ... 100 %RH)
At -40 ... 0 °C and +40 ... +80 °C	±3.0 %RH (0 ... 90 %RH)
	±4.0 %RH (90 ... 100 %RH)
At +80 ... +100 °C	±4.0 %RH ¹⁾

Humidity sensor	HUMICAP® 180R
Temperature measurement range	-40 ... +100 °C (-40 ... +212 °F), short-term up to +180 °C (+356 °F)
Temperature sensor	Pt1000 RTD Class F0.1 IEC 60751
Measurement probe	HM46PROBE
Probe head material	Stainless steel, brass filter
IP rating	IP40 (probe), IP54 (indicator)
Weight (with alkaline batteries)	490 g (17.3 oz)
Filter material	Sintered brass
Probe cable length	1500 mm (59 in)

¹⁾ Not recommended for $T_g > 85$ °C

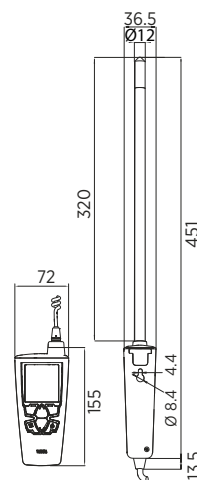

HM46 dimensions in mm

HM40 Series Technical Data

Measurement Performance

Calculated parameters	Dew point, wet bulb temperature, absolute humidity, mixing ratio, enthalpy
Relative Humidity	
Measurement range	0 ... 100 %RH
Accuracy (including non-linearity, hysteresis, and repeatability) for different models at 0 ... +40 °C (+32 ... +104 °F)	±1.5 %RH (0 ... 90 %RH) ±2.5 %RH (90 ... 100 %RH)
Factory calibration uncertainty at +20 °C (+68 °F):	
HM42 and HM46	±1.5 %RH
HM41 and HM45	±1.1 %RH (0 ... 90 %RH) ±1.8 %RH (90 ... 100 %RH)
Stability	±2 %RH over 2 years
Humidity Measurement Response Time:	
(90 %) with plastic grid filter (HM41 and HM45)	17 s
(90 %) with membrane filter and steel grid (HM42)	26 s
(90 %) with brass sintered filter (HM46)	40 s
Temperature	
Accuracy over temperature range:	
At 0 ... +40 °C (+32 ... +104 °F)	±0.2 °C (0.36 °F)
At -40 ... 0 °C and +40 ... +100 °C (-40 ... +32 °F and +104 ... +212 °F)	±0.4 °C (0.72 °F)

Operating Environment

Operating temperature	
Indicator	-10 ... +60 °C (+14 ... +140 °F)
Probe handle	-40 ... +60 °C (-40 ... +140 °F)
Probe head	Range -40 ... +180 °C (-40 ... +356 °F) See probe specifications
Storage temperature	-30 ... +70 °C (-22 ... +158 °F)
EMC compliance	EN61326-1, Portable Equipment

Mechanical Specifications

Materials	
Indicator body	PC/ABS blend, acrylic display lens
Probe holder	PC/ABS blend (gray)
Probe handle	PC/ABS blend (white), PC/ABS blend (gray, HM45) or PBT (gray, HM42/46)
HMP113 probe or probe measurement head	PC/ABS blend (white, HM41/45) or stainless steel (HM42/46)
IP rating, HM40	IP54

Indicator

Display	LCD (140 x 160 pixels)
Power-up time	< 3 s
Batteries	2 × AA, 1.5 V
Operation time (typical)	100 hours (without backlight)
Menu languages	English, Chinese (simplified), Finnish, French, German, Japanese, Portuguese, Russian, Spanish, Swedish

Spare Parts and Accessories

Indicator	
Spare HM40 indicator	HM40INDI
Belt clip (3 pcs)	227710SP
Battery cover (3 pcs)	225688SP
NiMH rechargeable batteries (4 pcs)	229247SP
External battery recharger with USB connection and 4 batteries	229249SP
Case for short HM40 probes	235849SP
Case for long HM40 probes	DRW242351SP
Standard Probe (HM41)	
HMP113 probe for HM40	HMP113 (configuration: V00B2C1A0)
Plastic locking bushing (3 pcs) for attaching HMP113 probe to HM40 indicator	DRW238590SP
Plastic grid filter for HMP113 probe	DRW236214SP
Plastic grid with membrane filter for HMP113 probe	230727SP
HM42 Probe (HM42)	
Thin 4 mm diameter probe for HM40	HM42PROBE
Steel grid filter for HM42PROBE	19867HM
Membrane tube set (5 pcs) for HM42PROBE	19858HM
Rubber sleeve set (10 pcs) for HM42PROBE	19809HM
Calibration adapter for HM42PROBE	HM37067
Remote Probe (HM45)	
HMP113 probe for HM40	HMP113 (configuration: V00B2C1A0)
Plastic locking bushing (3 pcs) for attaching HMP113 probe to HM40 indicator	DRW238590SP
HM40 handle and cable	HM40HANDLE
Plastic grid filter for HMP113 probe	DRW236214SP
Plastic grid with membrane filter for HMP113 probe	230727SP
HM46 Probe (HM46)	
Stainless steel 12 mm diameter probe for HM40	HM46PROBE
Sintered filter for HM46PROBE	0195
Optional membrane filter for HM46PROBE (up to +80 °C)	10159HM
Plastic grid filter for HM46PROBE (up to +80 °C)	6221
Disposable sleeve, 50 pcs set	1558
Probe holder	HM36915

CAB100 CMS Industrial Cabinet

For data collection in cleanrooms and industrial settings



Features

- Measurement options include differential pressure and analog inputs for a variety of parameters
- Analog inputs can be made intrinsically safe with a safety barrier or galvanic isolator
- Reporting via viewLinc is compliant with FDA, Annex 11, GxP, and GAMP
- Networking options include PoE and/or a multiport Ethernet adapter
- Large cabinets (CAB100B) feature an integrated 24 V DC / 2.5 A power supply
- Small cabinets (CAB100A) have the option of integrated power supply, or Power over Ethernet

Vaisala CMS Industrial Cabinet CAB100 integrates Vaisala's world-class instruments for monitoring differential pressure and other parameters into a simple, pre-configured instrument panel. In combination with the Vaisala viewLinc Enterprise Server software, the cabinet provides pre-installed real-time monitoring of your critical environments.

Easy data collection with quality and compliance

Cabinets are configurable to your application requirements, with options for differential pressure transmitters, analog inputs for the connection of remote transmitters, and safety barriers or galvanic isolators for hazardous areas that require intrinsically safe devices. CAB100 enables you to combine differential pressure and other transmitters with data loggers in a single enclosure for centralized monitoring and reliable alarming.

Configured for your cleanroom

CAB100 is designed to ensure regulatory compliance in multiple cleanroom applications, including: pharmaceutical, healthcare, biotechnology, medical

device, aerospace, automotive, and semiconductor manufacturing. Select from two cabinet sizes: small and large. Small cabinets can contain up to four analog inputs which can also be intrinsically safe, or four differential pressure transmitters. Large cabinets can accommodate up to 12 differential pressure transmitters and up to 32 analog input channels with intrinsically safe options.

Communication is achieved over Ethernet to the viewLinc server database. CAB100 is an ideal solution for many monitoring applications, providing device protection, economy and serviceability.

The lockable metal enclosure protects the measurement instruments from tampering and accidental damage.

The benefits of centralization

It is often impossible or impractical to run power or network cables to each desired point of measurement. With CAB100 you can centralize and economize by running a single power and network cable to the cabinet to support numerous transmitters, while also reducing the number of network adapters needed.

Centralization of measurement devices also simplifies serviceability. With multiple transmitters and data loggers located together, regular maintenance activities like calibration are easy and efficient.

CAB100 configuration options

Cabinet size and material (H × W × L)	Model CAB100A (small cabinet)	200 × 300 × 400 mm (7.87 × 11.81 × 15.75 in) Aluminum, painted white
	Model CAB100B (large cabinet)	200 × 500 × 600 mm (7.87 × 19.69 × 23.62 in) Stainless steel AISI 316, painted white
Powering	AC (mains) power	110–240 V AC, 50–60 Hz 0.5 A maximum (120 V AC)
	Power supply module within cabinet	24 V DC / 2.5 A / Fused 2 A
	Power over Ethernet ¹⁾	Power over Ethernet, with loop power, without fan
	Maximum power consumption	CAB100A: 20 W CAB100B: 40 W
IP rating	CAB100A (small cabinet)	IP54
	CAB100B (large cabinet)	IP66/NEMA 4
Analog channels	4–32 channels	4–20 mA
Safety barrier	1–16 pieces	1 barrier per channel
Galvanic isolator	1–12 pieces	1 isolator per channel
Differential pressure	1–12 pieces	±60 Pa or ±0.25 in H ₂ O
Ethernet communication	Model CAB100B (large cabinet)	Up to 2 serial-to-Ethernet devices via RJ45 (DIGI PortServer TS4)
	Model CAB100A (small cabinet)	Vaisala vNet Ethernet interface for DL series data loggers with PoE option via RJ45 connector
Ethernet	Ethernet switch	+4 PoE IEEE 802.3af/at
Compliance	Model CAB100A (small cabinet)	EN/IEC 61326-1 (Basic electromagnetic environment) ²⁾
	Model CAB100B (large cabinet)	CISPR 32 / EN 55032, Class A FCC part 15 B, Class A IEC/UL/EN 61010-1 SGS safety listed in USA and Canada CE, UKCA, China RoHS, and RCM compliant Conducted immunity: Output may deviate in 1–40 MHz environment, measured deviation ≤0.25 mA Radiated immunity: Output may deviate in 80–250 MHz environment, measured deviation ≤0.3 mA.

1) Only with PDTs and small CAB100.

2) Excluding CAB100 analog input channels, which are not surge protected.



CAB100 supports internal differential pressure transmitters, analog inputs, and safety barriers or galvanic isolators.

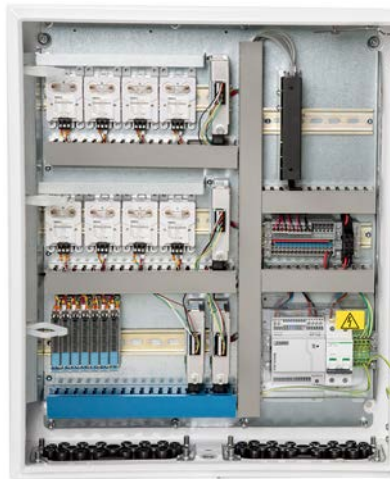

For accuracy specifications, see devices on www.vaisala.com

- DL4000 data loggers for multiple parameters
- PDT101 differential pressure transmitter
- HMT370EX series transmitters for intrinsically safe temperature and humidity measurement
- HMT120 and HMT130 series transmitters for analog inputs



Features

- Easy mounting on wall, DIN rail, or panel
- 3 pressure ranges (Pa and inH₂O)
- Unidirectional and bidirectional models
- Accessible zero and span adjustment potentiometers
- LED status indicator
- Dedicated models for critical and regulated environments and for air handling systems
- Euro style detachable connector
- Calibrations traceable to SI units through national metrology institutes or accredited calibration laboratories

Vaisala Differential Pressure Transmitter PDT101 offers precise measurement of differential air pressure. PDT101 offers dedicated models for critical and regulated environments with very low differential pressures and unidirectional models for air handling systems.

Operating environment

The highly accurate bidirectional models of PDT101 are designed especially for demanding life science and cleanroom applications, and are the perfect choice for any application requiring precise pressure differential measurement. The transmitter is ideal for incorporating into the Vaisala viewLinc Continuous Monitoring System to measure and monitor the critical environmental parameters as required in regulated environments.

The unidirectional models of PDT101 are optimal for air handling units to measure differential pressure over fans or filters, for example.

Zero and span adjustment screws are available on every PDT101 model. Both adjustments are accessible from the front of the unit.

Performance

PDT101 offers high accuracy, sensitivity, and stability, with models providing accuracies of either 0.40 or 1 % of span. The sensor uses a micro-machined, ultra-thin silicon diaphragm which provides inherent sensor repeatability and stability. The sensor enables precise measurement and control in high performance environments. The PDT101 transmitter is available with voltage output (3-wire) or current output (2-wire).

Applications

PDT101 is suitable for high performance environments in the life science, semiconductor, and electronics industries, as well as in building automation systems in data centers and other demanding buildings and environments.

When used in regulated environments as part of the viewLinc system, it is highly suitable for fulfilling the requirements of continuous, documented, and redundant data, to meet FDA, EMA and other international regulations.

The compact design is well suited for mounting in a cleanroom or in the adjacent corridor with LED indicator lights for quick and easy power status spot check.

Technical data

Models

Model	Measurement range	Output
PDT101-P4C	±60 Pa	4–20 mA
PDT101-P4V	±60 Pa	0–5 V
PDT101-P4C2	±125 Pa	4–20 mA
PDT101-P4V2	±125 Pa	0–5 V
PDT101-W4C	±0.25 inH ₂ O	4–20 mA
PDT101-W4V	±0.25 inH ₂ O	0–5 V
PDT101-W4C2	±0.5 inH ₂ O	4–20 mA
PDT101-W4V2	±0.5 inH ₂ O	0–5 V
PDT101-P10C	0–500 Pa	4–20 mA
PDT101-P10V	0–500 Pa	0–10 V
PDT101-W10C	0–2 inH ₂ O	4–20 mA
PDT101-W10V	0–2 inH ₂ O	0–10 V
PDT101-P10Cx ¹⁾	0–500 Pa	4–20 mA
PDT101-P10Vx ¹⁾	0–500 Pa	0–10 V
PDT101-W10Cx ¹⁾	0–2 inH ₂ O	4–20 mA
PDT101-W10Vx ¹⁾	0–2 inH ₂ O	0–10 V

¹⁾ The PDT101-P10Cx, PDT101-P10Vx, PDT101-W10Cx, and PDT101-W10Vx models do not include calibration certificate.

Measurement performance

Measurement ranges (bidirectional)	±60 Pa, ±125 Pa, ±0.25 inH ₂ O, or ±0.5 inH ₂ O
Measurement ranges (unidirectional)	0–500 Pa, or 0–2 inH ₂ O
Accuracy (incl. non-linearity, hysteresis, repeatability and zero/span calibration settings)	0.4 % of span (bidirectional models), 1% of span (unidirectional models)
Long-term stability	≤ 0.5 % span/year
Response time (10–90 %)	250 ms
Warm-up time	15 s
Compensated temperature range	+2 ... +54 °C (+35.6 ... +129.2 °F)
Temperature dependence	±(0.065 Pa + 0.054 % of reading) / °C or ±(0.00015 inH ₂ O + 0.03 % of reading) / °F (reference 21 °C or 70 °F)
Pressure type	Differential, gauge, vacuum and compound
Overpressure	
Proof pressure	1.0 bar
Burst pressure	1.7 bar
Static pressure	1.7 bar
Mounting position	
Error (zero adjustable)	≤ 1 %/g (calibration in vertical position is standard)
Adjustments (front accessible)	
Zero	±5 % span
Span	±3 % span

Compliance

EU directives and regulations	EMC
Electromagnetic compatibility (EMC)	EN 61326-1, basic immunity test requirements
Compliance marks	CE, RCM

Mechanical specifications

Medium (measured gas)	Clean and dry air, non-conducting and non-corrosive gases
Mounting	Threaded fastener for wall mounting or DIN rail type EN 50022
IP rating	IP40
Weight	0.07 kg
Material	
Process connection	Brass
Sensor element	Silicon, aluminum, glass
Case	NEMA type 1 fire-retardant ABS 1 (meets UL94-5VA)

Inputs and outputs

Process connection	1/4" barbed fittings
Tubing outer and inner dimensions	Outer dimension (O.D): 1/4" (6.35 mm) Inner dimension (I.D): 1/8" (3.17 mm)
Max. loop resistance for 4 ... 20 mA	≤ (Supply voltage - 12 V) / 0.022 A
Supply current	Max. 20 mA for 4–20 mA output signal
Optical process diagnostics	LED visual indicator
Electrical connection	Euro style pluggable terminal block accepts 12–26 AWG wire (0.13 up to 3.31 mm ²)

Output signal	
2-wire	4–20 mA
3-wire	0–5 or 0–10 V DC (user selectable)
Operating voltage	
2-wire output 4–20 mA	12 ... 36 V DC
3-wire output 0–5 V DC	11.5–36 V DC or 24 V AC
3-wire output 0–10 V DC	14–36 V DC or 24 V AC

Operating environment

Operating temperature	–18 ... +70 °C (–0.4 ... +158 °F)
Storage temperature	–40 ... +82 °C (–40 ... +179.6 °F)

Note: If used in an electromagnetic field of 3 V/m, with narrow frequency area of 80 ... 120 MHz, it is possible that the current output of PDT101 can deviate max. 0.8 % (with accuracy specified 0.4 %)

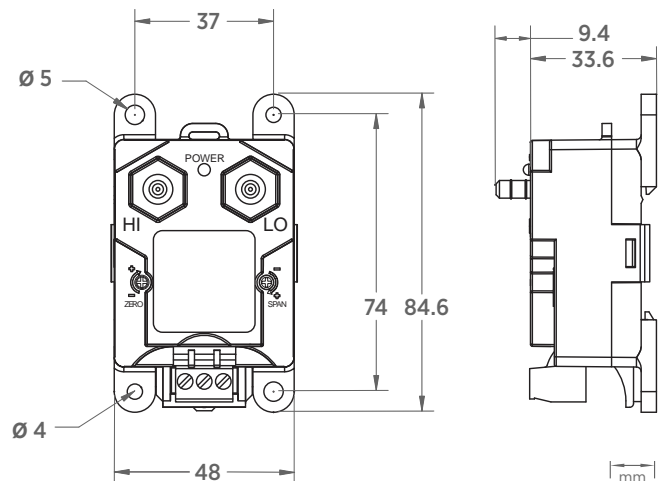

PDT101 dimensions



Features

- In-place system calibration and online monitoring without disturbing process tubes with optional process valve actuator and test jacks
- Ultrathin profile ideally suited for DIN rail mount reduces installation and calibration costs
- High accuracy, two options; 0.25 % or 0.50 % of span
- Extremely robust MEMS silicon sensor technology provides very high accuracy, sensitivity, stability, and durability
- Calibrations traceable to SI units through national metrology institutes or accredited calibration laboratories
- Front side accessible zero and span adjustment potentiometers

Vaisala Differential Pressure Transmitter PDT102 offers ultra low pressure measurement for cleanroom control and monitoring applications.

Operating environment

Vaisala Differential Pressure Transmitter PDT102 is a high performance instrument designed primarily for life science and high technology cleanroom applications. The front panel includes zero and span adjustment potentiometers for convenient adjustment. The PDT102 transmitter is ideal for incorporating into the Vaisala viewLinc Continuous Monitoring System to measure and monitor the critical environmental parameters as required in regulated environments.

Performance

PDT102 offers very high accuracy, sensitivity and stability with two options for accuracy, 0.25% or 0.50% of span providing a highly reliable and

repeatable measurement. The sensor uses a micro-machined, ultra-thin silicon diaphragm which provides inherent sensor repeatability and stability. The sensor enables precise measurement and control in high performance cleanrooms. The PDT102 transmitter is available with voltage output (3-wire) or current output (2-wire).

Available options

Online monitoring of PDT102 is simple using the optional process valve actuator and the front access test jacks. The front access test jacks provide online process reference signal or calibration signal without disconnecting power supply wiring. Measurements can be made using a standard multimeter.

Applications

PDT102 is designed for use in critical monitoring of cleanrooms for pharmaceutical, biotechnology, medical device, and semiconductor controlled manufacturing environments.

Technical data

Measurement performance

Measurement ranges (bidirectional)	±50 Pa ±0.25 in H ₂ O
Accuracy ¹⁾	0.25 % span or 0.5 % span, depending on choice
Repeatability for 0.25 % span accuracy	0.03 %
Repeatability for 0.5 % span accuracy	0.05 %
Electrical resolution	1 x 10 ⁻⁴ span
Long-term stability	≤0.5 % span/year
Response time (10– 90 %)	250 ms
Warm-up time	15 s
Compensated temperature range	+2 ... +57 °C (+35.6 ... +134.6 °F)
Temperature dependence	±(0.036 Pa + 0.036 % of reading) / °C or ±(0.0001 in H ₂ O + 0.02 % of reading) / °F (reference 21 °C or 70 °F)
Pressure type	Differential, gauge, vacuum and compound
Overpressure	
Proof pressure	0.7 bar
Burst pressure	1.7 bar
Static pressure	1.7 bar
Mounting position	
Error (zero adjustable)	≤0.25 %
Adjustments (front accessible)	
Zero	±5 % span
Span	±3 % span

¹⁾ Incl. non-linearity, hysteresis, repeatability and zero/span calibration settings.

Inputs and outputs

Process connection	1/8 NPT female according to ANSI/ ASME B1.20.1
Tubing dimensions	Outer dimension (O.D.): 1/8" (3.17 mm)
Operating voltage	12–36 V DC
Max. loop resistance for 4–20 mA	≤ (Supply voltage - 12V)/0.022 A
Electrical connection	Screw terminals, 12– 22 AWG (0.33 up to 3.31 mm ²)
Output signal	
2-wire	4–20 mA
3-wire	0–5 V
Supply current	
For 0–5 V output	Max. 10 mA
For 4–20 mA output	Max. 20 mA

Mechanical specifications

Medium (measured gas)	Clean and dry air, non-conducting and non-corrosive gases
Mounting	DIN rail types EN 50022, EN 50035 and EN 50045
Weight	0.16 kg
Material	
Process connection	Brass
Sensor element	Silicon, aluminum, glass
Case	Polycarbonate, glass filled (UL94-V-1)

Operating environment

Operating temperature	–29 ... +70 °C (–20.2 ... +158 °F)
Storage temperature	–40 ... +82 °C (–40 ... +179.6 °F)
IP rating	IP30

Note: If used in an electromagnetic field of 3 V/m, with narrow frequency area of 80 - 120 MHz, it is possible that the current output of PDT102 can deviate max. 0.3 % (with accuracy specified 0.25 %)

Compliance

EU directives and regulations	EMC
Electromagnetic compatibility (EMC)	EN 61326-1, basic immunity test requirements
Compliance marks	CE, RCM

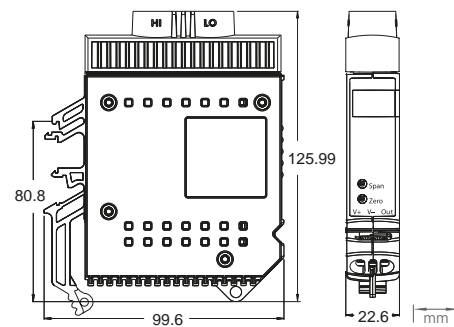

PDT102 transmitter dimensions

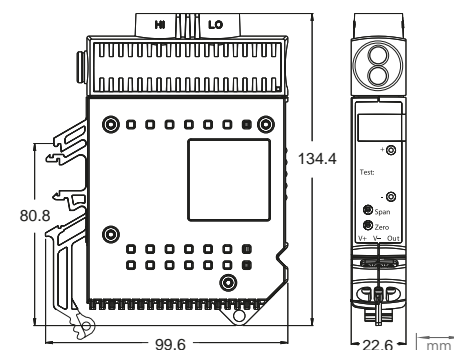

PDT102 dimensions with process valve actuator and test jacks

PDT102 - XXXT

Measurement range:
P (+/-50 Pa) or **W** (+/-0.25 in H₂O) ———— ↑ ↑ ↑
 Accuracy: **2** (0.25 % span) or **5** (0.5 % span) ———— ↑
 Output: **C** (current) or **V** (voltage) ———— ↑
 Option: (blank) or **T** ———— ↑

Order information for PDT102



Features

- Easy and reliable calibration of humidity probes and transmitters
- Based on saturated salt solutions
- Fast temperature equilibration
- No external power required
- Suitable for laboratory use and on-site checks
- Chambers and transit covers make HMK15 easy to transport
- Pre-measured certified salts available
- Vaisala Service Centers offer accredited calibrations for humidity, temperature, and barometric pressure

No measuring instrument stays accurate by itself. It is essential that the functioning of an instrument is periodically checked against a reference. Vaisala has developed Vaisala Humidity Calibrator HMK15 to make calibration and spot-checking of humidity probes and transmitters easy and reliable.

Benefits

- Easy to use
- Reliable calibration
- Certified and pre-measured salts available on order form of HMK15

Reliable calibration method

The operating principle of HMK15 is based on the fact that a saturated salt solution generates a certain relative humidity in the air above it. The reading of the humidity probe or transmitter can then be adjusted accordingly. Many calibration laboratories use this generally accepted and reliable method to

calibrate humidity instruments. Usually two or three different salt solutions are used. Salts are chosen according to the application. Available salts and their reference humidities:

- Lithium chloride LiCl (11 %RH)
- Magnesium chloride $MgCl_2$ (33 %RH)
- Sodium chloride NaCl (75 %RH)
- Potassium chloride KCl (85 %RH)
- Potassium sulphate K_2SO_4 (97 %RH)

Certified salts

HMK15 can be ordered with certified and pre-measured salts. A sample calibration is made from each salt batch in Vaisala's Measurement Standards Laboratory (MSL).

FINAS accredited measurement standards laboratory

Vaisala's Measurement Standards Laboratory is a FINAS accredited calibration laboratory. FINAS is a member of the EA (the European Cooperation for Accreditation).



Technical data

Operating environment

Operating temperature range	+0 ... +50 °C (+32 ... +122 °F)
-----------------------------	---------------------------------

Mechanical specifications

Dimensions (H × W × L)	90 × 230 × 200 mm (3.54 × 9.06 × 7.87 in)
Weight	1 kg (2.20 lb) without salt solutions
Material (metal parts)	Anodized aluminum

Parts

Standard contents of HMK15 calibrator

Base plate
Two salt chambers with basic lids and transit covers
Thermometer
Measurement cup and mixing spoon
Calibration adapter (Ø13.5 mm) for Ø12 mm probes with long sensor legs
Calibration adapter (Ø13.5 mm) for Ø12 mm probes with short sensor legs

Optional items

See table *Spare parts and accessories*

Spare parts and accessories

Rubber plug set	19746HM
O-ring set	218096
Ion exchanged water	19767HM
Thermometer with red capillary liquid	25130HM
Transit bag	HM27032

Salt chambers and lids

HMK15 basic lid	271549
HMK15 universal lid	271550
HMK15 custom lid for 4 × HMP110 with filter on	253277SP
HMK15 custom lid for DMT132 and HMP60/HMP110 with filter on	230914
HMK15 salt chamber with basic lid and transit cover	DRW255417SP
HMK15 salt chamber with universal lid and transit cover	19766HM

Calibration adapters

Calibration adapter for HMP9 probe	ASM213801
Calibration adapter (Ø13.5 mm) for Ø12 mm probes with long sensor legs	211302SP
Calibration adapter (Ø13.5 mm) for Ø12 mm probes with short sensor legs	218377SP
Calibration adapter for HMP42 probe	HM37067

Certified and ready-dosed salts ¹⁾

Ready-dosed LiCl salt package (LiCl salt 11 %RH, total uncertainty ±1.3 %RH) ²⁾	19729HM
Ready-dosed MgCl ₂ salt package (MgCl ₂ salt 33 %RH, total uncertainty ±1.2 %RH) ²⁾	19730HM
Ready-dosed NaCl salt package (NaCl salt 75 %RH, total uncertainty ±1.5 %RH) ²⁾	19731HM
Ready-dosed KCl salt package (KCl salt 85 %RH, total uncertainty ±2.0 %RH) ²⁾	251377HM
Ready-dosed K ₂ SO ₄ salt package (K ₂ SO ₄ salt 97 %RH, total uncertainty ±2.0 %RH) ²⁾	19732HM

¹⁾ Calibration certificate included with each salt package.
²⁾ Uncertainties given at +20 °C (+68 °F).



Our service offering

- Maintenance Agreement
- Installation and configuration
- Validation
- Calibration services
- Training
- Validation mapping

Vaisala provides comprehensive customer care for the entire life cycle of the Vaisala viewLinc Continuous Monitoring System (CMS). These expert services will ensure that your CMS provides reliable monitoring throughout its operational lifespan.

Worldwide experts at your service

Vaisala's service and support teams provide you with an in-depth understanding of critical environments, network technologies, and measurement devices. We help ensure that your CMS is efficiently and effectively deployed so that it meets or exceeds the most stringent compliance requirements for installation in GxP-regulated environments.



"The Vaisala team is well qualified, easy to work with, and became a part of our team. This relationship was a major reason that our original goal of project completion [for a 2000 point, 60 site system] within two years was met."

Joe Cwierniewicz,
Facilities Manager, McKesson

Choose the optimal combination of life cycle services for your viewLinc CMS:



MAINTENANCE
AGREEMENT



INSTALLATION &
CONFIGURATION



IQ/OQ
VALIDATION



CALIBRATION
SERVICES



TRAINING



VALIDATION
MAPPING

viewLinc Life Cycle Maintenance Agreement

Our life cycle services provide you with expert support throughout the lifetime of your CMS to ensure reliable monitoring. Choose the services that suit your needs best, or consult our experts to help you decide.

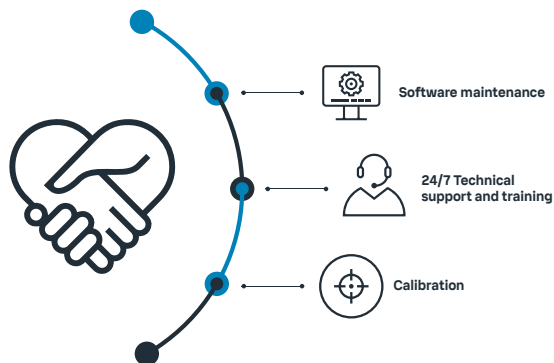

viewLinc Life Cycle Maintenance Agreement

The viewLinc Life Cycle Maintenance Agreement (LCMA) is an agreement designed to ensure that your viewLinc CMS is always up to date in terms of performance and regulatory compliance. It also helps ensure you get maximum benefit from your viewLinc CMS with support from our experts. The agreement comprises software updates, enhanced support and training for your staff, and remote emergency support.

Software updates

Software updates ensure that your viewLinc CMS is updated regularly to address technological advances and changes in regulations. Updates are provided free of charge and include supporting documentation.

Enhanced support and training for your staff

Enhanced support means that Vaisala technical experts will help you to solve any technical challenge you might face when using Vaisala hardware and software. All queries are answered by a Vaisala expert on the next working day at the latest. The service also includes a fixed amount of pre-planned training and/or consultation on topics of your choosing. Training is recommended when you first start using viewLinc and when you are onboarding new staff.

For technical support, contact us via MyVaisala portal or Vaisala helpdesk at helpdesk@vaisala.com.

Remote emergency support

Remote emergency support is available to help troubleshoot the root cause of critical issues with Vaisala hardware and software that inhibit core system functions. Support is available 24/7 via Vaisala's dedicated emergency support number.



"Over the years, Vaisala's field support has assisted us for complex system integrations, supporting all our needs effectively. Vaisala has enabled us to reduce the time it takes to create a fully GMP-monitored environment. That provides us with a competitive edge."

David Teer, Senior Engineering Manager, Viral-based Therapeutics, Lonza Houston.

Installation and configuration

Vaisala’s experienced technicians are available to manage and perform the installation and configuration of your viewLinc CMS. Our installation service ensures flawless system deployment and efficient start-up without burdening your resources. We also offer update and expansion services for existing viewLinc systems.

Installation service includes:

- Collaborative planning
- Installation of all measurement devices and network hardware
- Software installation and configuration
- User and administrator training
- System handover



Efficient and worry-free installation

With our comprehensive installation service you can be certain that the system deployment meets all your operational and regulatory requirements.

Comprehensive training

Our installation service includes hands-on user and administrator training to ensure staff can make effective use of the CMS from day one.

Expert support

Vaisala’s service technicians have expert knowledge of our hardware, software, and associated technologies. They are experienced in setting up systems for critical and GxP-regulated environments.

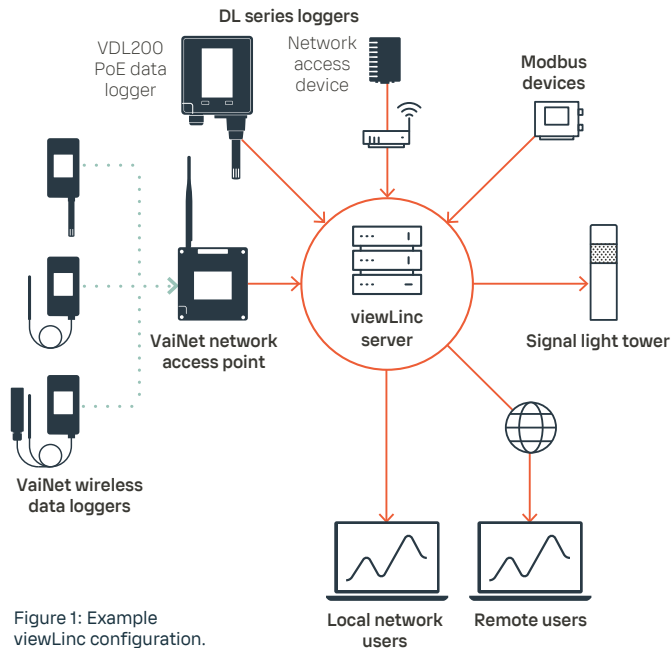

Figure 1: Example viewLinc configuration.

“The system was installed with the help of Vaisala Field Service. When a Joint Commission surveyor returned, we presented him with printouts of viewLinc records for the dates and times of his choosing. He was impressed.”

Frank Gee, Director of Facilities,
Hazel Hawkins Memorial Hospital, California

Validation

Ensure a high quality validation of your monitoring system and reduce system implementation time by using our expertise and understanding of GxP quality systems.



IQ/OQ validation

Ensure high-quality validation of your monitoring system and reduce system implementation time by using our expertise and understanding of GxP quality systems.

Vaisala offers on-site Installation Qualification (IQ) and Operational Qualification (OQ) services for the Vaisala viewLinc CMS.

IQ captures the baseline configuration of your system and provides evidence of control that aligns with GxP guidelines. OQ provides evidence that your monitoring system is operating as designed, encompassing all GxP functions of the system including audit trails, tamper-proof data, and the relevant requirements of 21 CFR Part 11, EU GMP Annex 11, and PSFB 040122.

Economical and efficient

Monitoring system validation performed by a skilled and experienced Vaisala technician is an economical choice, providing significant savings in time and resources. Let us take care of IQ/OQ system validation so that you can concentrate on your core business.

The quickest way to audit-ready monitoring

Our understanding of GxP regulations and quality system standards in life science industries ensures that your viewLinc CMS is validated, documented, and ready for regulatory scrutiny.

Comprehensive validation documents

Our validation service includes full documentation to demonstrate that the system is operating according to specifications and that it meets quality standards and regulatory requirements.

“The viewLinc system is not only easy to validate to GMP compliance, but it’s also more efficient than all the hard wiring typically required by automation and control systems.”

David Teer, Senior Engineering Manager, Viral-based Therapeutics, Lonza Houston

Calibration services

Vaisala offers several calibration options for CMS data loggers and instruments to verify and ensure their measurement accuracy.

Simply choose from Service Center Calibration, On-site Calibration, or our Probe-Swapping Service and leave the rest to our experts. All calibration options include official calibration certificates for both internal and external audit purposes.

We also offer cost-efficient Calibration Care agreements which include priority processing. You can learn more about the benefits of a Calibration Care agreement at vaisala.com/en/services/calibration-services.



Service Center Calibration

Traceable ISO 9001 or accredited ISO/IEC 17025 calibration performed at a Vaisala calibration laboratory:

- Wide calibration ranges and extensive options
- Adjustment included and repair services available as an option
- Includes calibration certificate with as-found and as-left results

On-site Calibration

Single or multi-point calibration, accredited if required, performed at your site by Vaisala experts:

- No system downtime or lost data
- Carefree and convenient – saves in-house resources
- Includes calibration certificate

Probe-Swapping Service

Avoid calibration-related downtime with our Probe-Swapping Service, which provides you with a replacement probe with an as-found calibration certificate.

- Factory calibration accuracy with minimal downtime
- Probe replacement can be performed in seconds

Vaisala service centers providing ISO and Accredited calibration services

Boston	Helsinki	Beijing	Tokyo
  <p>CALIBRATION LABORATORY CERTIFICATE # 2083.01</p>	  <p>Finnish Accreditation Service K008 (EN ISO/IEC 17025)</p>	  <p>中国认可 国际互认 校准 CALIBRATION CNAS L10243</p>	  <p>JCSS JCSS 0123</p>
<p>ALL PARAMETERS CALIBRATED: Relative Humidity, Temperature, Dew Point, Pressure, Carbon dioxide and Hydrogen peroxide</p>			
<p>Please visit store.vaisala.com to see services availability and terms in your area.</p>			

Training

Vaisala offers comprehensive training services for viewLinc customers to ensure staff are properly trained on the system's functions and capabilities. Whether you are deploying a new monitoring system, expanding an existing one, or adapting to staff changes, our comprehensive training ensures proper use of the system and compliance with regulations such as FDA 21 CFR 211.25.



Choose the training option that serves your needs best:

- Remote training with Vaisala technical support experts via Teams
- On-site training with hands-on exercises; typically delivered with our Installation Service.

Validation mapping

Understanding the critical process parameters of a controlled environment is crucial to the safe and effective use of that space for manufacturing, storing, processing, and distributing pharmaceuticals, biological materials, and medical devices. The Vaisala Validation Mapping Service ensures that you fully understand the variability of conditions and qualify controlled environments.

The Validation Mapping Service includes:

- Thermal mapping and analysis of environments
- Mapping equipment used during the service
- Mapping study documents

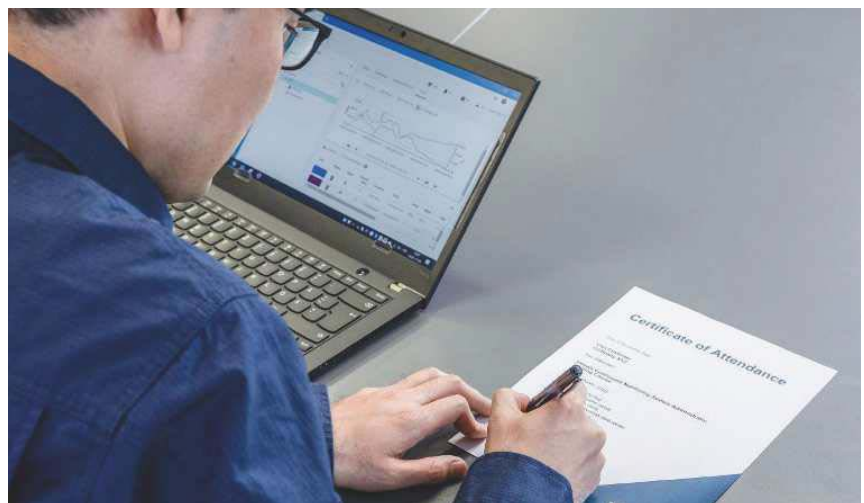

"As our research has evolved, viewLinc has met our needs. We are extremely pleased with the viewLinc system and the services Vaisala provides."

Dr. Leonardo Motta, Medical Laboratory Supervisor, Health Research Institute, University of Caxias do Sul, Brazil



Features

- Achieve time and cost savings by preventing production downtime
- Ensure highly accurate measurements
- Provide certification and mandatory documentation for instrument calibration standards
- Free up staff to focus on primary work assignments
- Enjoy peace of mind with Vaisala-certified calibration expertise and components
- Take advantage of a wide array of available calibrations

Calibrating Vaisala Continuous Monitoring Systems (CMS) on-site helps to maximize reliability and profitability by minimizing costly equipment downtime, removing the need for in-house or factory calibration, and allowing your staff to focus on what is truly important: your business.

Reliable On-site Calibration for Life Science Applications

On-site Calibration Service offers a range of benefits over the conventional options of either shipping equipment back to the manufacturer or calibrating in-house. Reliable on-site calibration minimizes downtime by keeping your monitoring system in place and operational.

Certain calibrations require removal of the device from process. For these situations Vaisala offers rental devices and device swap services to ensure continuity of monitoring and gap-free

data. By outsourcing calibration to Vaisala, you remove the need to invest in specialized calibration equipment and training – allowing staff to focus on their primary tasks.

We provide you with a range of single- and multi-point calibration options using application-specific reference instruments, complete with a certificate of NIST traceability. To maintain the high levels of accuracy and optimal performance of your CMS, the system sends a reminder when calibration is due.

Complete Documentation

On-site Calibration Service provides a thorough analysis with comprehensive paper and digital documentation, including a calibration certificate to ensure verification and standards compliance. Calibration reports, data sheets, and calibration labels can be supplied on-site, with digital backup files saved to disk. Our highly accurate calibrations fulfill international standards and make it easy to comply with regulatory requirements.

Technical Data

Single-point Calibration

Temperature	
Range	-90 ... +70 °C
Unit Under Test acceptance limits	±1 °C
Calibration points	One point at point of use
Adjustment	Not available
Certificate	Includes as-found/as-left data
Traceability	NIST
Available for the following devices	Vaisala Temperature Data Loggers <ul style="list-style-type: none"> • DL1000 • DL1016 • DL1400 • DL1416 • DL2000 • HMT140
Reference instrument	Vaisala Temperature Data Logger
Temperature for Liquid Nitrogen Applications	
Range	-196 °C
Unit Under Test acceptance limits	±3 °C
Calibration points	One point at point of use
Adjustment	Not available
Certificate	Includes as-found/as-left data
Traceability	NIST
Available for the following devices	Vaisala Temperature Data Loggers DL1700
Reference instrument	Vaisala Temperature Data Logger, Fluke 52 Series II
Relative Humidity	
Range	Ambient RH (within range of 10 ... 90 %RH) at any temperature within range of +10 ... +45 °C
Unit Under Test acceptance limits	±5 %RH
Calibration points	One point at point of use
Adjustment	Not available
Traceability	NIST
Applicable loggers and transmitters	Vaisala Humidity Data Logger DL2000, HMT140
Reference instrument	Vaisala Humidity Data Logger
Carbon Dioxide	
Range	0 ... 20 % at point of use
Unit Under Test acceptance limits	Application dependent
Calibration points	One point at point of use
Adjustment	Not available
Certificate	Includes as-found/as-left data
Traceability	NIST
Available for the following devices	Vaisala Carbon Dioxide Transmitter Series GMT220
Reference instrument	Vaisala GM70

Multi-point Calibration

Temperature	
Range	-90 ... +90 °C
Unit Under Test acceptance limits	±0.5 °C
Calibration points	Application-dependent
Adjustment	Available on 3+ point calibrations
Certificate	Includes as-found/as-left data and uncertainties
Traceability	NIST
Available for the following devices	Vaisala Temperature Data Loggers with Probes <ul style="list-style-type: none"> • DL1000 • DL1016 • DL1400 • DL1416 • HMT143 • HMT148
Reference instrument	Ametek ETC159
Relative Humidity	
Range	10 ... 90 %RH at ambient temperature
Unit Under Test acceptance limits	Loggers ±3 %RH
Calibration points	Application-dependent
Adjustment	Available on 3+ point calibrations
Certificate	Includes as-found/as-left data and uncertainties
Traceability	NIST
Available for the following devices	Vaisala Relative Humidity Data Loggers HMT141, DL2000
Reference instrument	Vaisala HMT330
Differential Pressure	
Range	-15 ... 200 psi
Unit Under Test acceptance limits	Range-dependent
Calibration points	Application-dependent
Adjustment	Available on 3+ point calibrations
Certificate	Includes as-found/as-left data
Traceability	NIST
Available for the following devices	Vaisala Differential Pressure Transmitter Series PDT100
Reference instrument	Fluke Process Calibrator / Pressure Modules
Current and Voltage	
Range	0 ... 5 VDC 0 ... 10 VDC 0 ... 20 mA
Unit Under Test acceptance limits	±0.15 %FS at +25 °C
Calibration points	Match Factory Calibration
Adjustment	Yes
Certificate	Includes as-found/as-left data and uncertainties
Traceability	NIST
Available for the following devices	Vaisala Relative Data Loggers HMT140, DL4000, DL2000
Reference instrument	National Instruments PHLe-4141



GxP Documentation Package for Vaisala viewLinc Continuous Monitoring System



Features

- System validation documentation package designed to provide ISPE Good Automated Manufacturing Practice (GAMP) methodology for viewLinc system validation.
- Available in English, Portuguese, Japanese, and Chinese.
- Specify the required attributes of your viewLinc system using the viewLinc-specific GxP documentation:
 - User Requirements Specification
 - Functional Specification
 - Design Qualification
 - Traceability Matrix
 - Risk Assessment

Vaisala viewLinc Continuous Monitoring System is ideal for GxP-regulated applications and environments that contain high-value products. If you are required to maintain compliant environmental monitoring methods and documentation, Vaisala can provide a GxP System Documentation package for the viewLinc monitoring system to help ensure your system implementation fulfills the recommendations of ISPE Good Automated Manufacturing Practice (GAMP).

Specify, then verify

The goal of the GAMP approach is to ensure, through specification and testing, that the monitoring system is fit for its intended use and implemented in a controlled manner. The required attributes of the system are described in specifications, and then verified in testing. The GxP Documentation Package provides the required specifications, which can then be verified using the Vaisala IQOQ (Installation Qualification/Operation Qualification) Documentation Package.

User Requirements Specification (URS)

The User Requirements Specification defines the capabilities you have deemed necessary for the Vaisala Continuous Monitoring System to fulfil its intended role in your process. This document provides a clear and concise list of requirements for a typical continuous monitoring application, while providing the option to add new requirements according to your unique business processes.

Functional Specification (FS)

The Functional Specification outlines all functions of the Vaisala Continuous Monitoring System. This document can be used by stakeholders to evaluate the CMS as a candidate system by comparison to a User Requirements Specification.

Design Qualification (DQ)

The Design Qualification ensures that the Vaisala Continuous Monitoring System is appropriately designed and capable of meeting the requirements of the system user. The DQ compares individual User Requirements in the URS against the system functions, and provides traceable verification that each User Requirement is fulfilled by a function listed in the FS.

Traceability Matrix (TM)

The Traceability Matrix ensures traceability of the requirements through the assessment and testing processes. The Traceability Matrix is used to verify that each requirement from the URS is fulfilled by a corresponding function in the CMS. It verifies that each requirement and corresponding function has been fully evaluated through Risk Assessment, IQ Testing, and OQ Testing.

Risk Assessment (RA)

The Risk Assessment outlines the CMS functions that are critical to preserving the safety and efficacy of GxP products. This Risk Assessment provides justification for the items in the Vaisala CMS that will be tested (or not tested). This analysis serves as a guide for your testing efforts.

A central tenet of GAMP philosophy is to leverage supplier involvement. Items identified as not requiring testing in the CMS IQOQ have either been tested thoroughly by Vaisala during system development, or are tested elsewhere during the implementation process.

More information

For more information on the GxP Documentation Package for viewLinc, see www.vaisala.com/gamp-gxp-validation.

Vaisala contact information

EUROPE

FINLAND	BENELUX	FRANCE	
Vaisala Oyj P.O. Box 26 FI-00421 Helsinki FINLAND www.vaisala.com/requestinfo www.vaisala.com	Contact: Bonn Office Vaisala GmbH Rheinwerkallee 2 D-53227 Bonn GERMANY benelux.sales@vaisala.com www.vaisala.com/de	Vaisala SAS Lyon Office 73 cours Albert Thomas F-69003 LYON FRANCE ventes@vaisala.com www.vaisala.com/fr	Vaisala SAS Paris Office Tech Park 6A, Rue René Razel F-91400 Saclay FRANCE ventes@vaisala.com www.vaisala.com/fr
GERMANY		ITALY	SWITZERLAND
Vaisala GmbH Bonn Office Rheinwerkallee 2 D-53227 Bonn GERMANY vertrieb@vaisala.com www.vaisala.com/de	Vaisala GmbH Hamburg Office Notkestraße 11 D-22607 Hamburg GERMANY vertrieb@vaisala.com www.vaisala.com/de	Vaisala Oyj Milan Office Via Carlo Cattaneo 9 21013 Gallarate (VA) ITALY www.vaisala.com/it	Contact: Bonn Office Vaisala GmbH Rheinwerkallee 2 D-53227 Bonn GERMANY vertrieb@vaisala.com www.vaisala.com/de
SWEDEN		UNITED KINGDOM	
Vaisala Oyj Malmö Office WTC / Jungmansgatan 12 S-211 11 Malmö SWEDEN forsaljning@vaisala.com www.vaisala.com	Vaisala Oyj Stockholm Office forsaljning@vaisala.com www.vaisala.com	Vaisala Ltd Bury St. Edmunds Office Unit 2b, Hillside Business Park Kempson Way Bury St. Edmunds Suffolk IP32 7EA UNITED KINGDOM uksales@vaisala.com www.vaisala.com	Vaisala Ltd Birmingham Office 6230 Bishops Court Solihull Parkway Birmingham Business Park Birmingham B37 7YB UNITED KINGDOM uksales@vaisala.com www.vaisala.com

AMERICAS

U.S.A.	CANADA	MEXICO	BRAZIL
Vaisala Inc. Boston Office 3 Van De Graaff Drive Suite 140 Burlington, MA 01803 U.S.A. instruments@vaisala.com www.vaisala.com	Vaisala Canada Inc. Vancouver Office 200-15225 104 Avenue Surrey BC, V3R 6Y8 CANADA instruments@vaisala.com www.vaisala.com	Vaisala México Limited México Office Sócrates 140 Col. Polanco Sección II Del. Miguel Hidalgo CP 11540, CDMX MÉXICO www.vaisala.com/es	Vaisala Serviços de Marketing Ltda Rio de Janeiro Office Ladeira da Gloria 26 Bloco 3 - Studio 206 Glória, Rio de Janeiro RJ 22211-120 BRAZIL www.vaisala.com/pt

Continued overleaf

ASIA AND PACIFIC

AUSTRALIA

Vaisala Pty Ltd
Melbourne Office
3 Guest Street
Hawthorn, VIC 3122
AUSTRALIA
sales.melbourne@vaisala.com
www.vaisala.com

CHINA

Vaisala China Ltd
Beijing Office
Floor 36, Block B, Guorui Plaza
No. 1 Ronghua South Road
Beijing Economic and Technological
Development Area
100176 Beijing
P.R. CHINA
chinasales@vaisala.com
www.vaisala.cn

Vaisala China Ltd
Shanghai Branch
Room 2601-2602, Office Tower 1
Grand Gateway, 1 Hongqiao Road
Xuhui District
200030 Shanghai
P.R. CHINA
chinasales@vaisala.com
www.vaisala.cn

JAPAN

Vaisala KK
Tokyo Office
Jimbocho Mitsui Building 16F
1-105 Kanda-Jimbocho
Chiyoda-ku
Tokyo 101-0051
JAPAN
sales.japan@vaisala.com
www.vaisala.com/ja

Vaisala KK
Osaka Sales Office
H¹O Umeda-Chayamachi 7F
16-38 Chayamachi
Kita-ku, Osaka-shi
Osaka 530-0013
JAPAN
sales.japan@vaisala.com
www.vaisala.com/ja

Vaisala KK
Fukuoka Sales Office
Across Cube 3F
3-4-25, Hakata-ekimae
Hakata-Ku, Fukuoka-Shi
Fukuoka 812-0011
JAPAN
sales.japan@vaisala.com
www.vaisala.com/ja

KOREA

Vaisala Korea Co., Ltd
101-1514, Gwanmun-ro 92
Gwacheon-si
Gyeonggi-do, 13807
REPUBLIC OF KOREA
www.vaisala.com/ko/home

MALAYSIA

Vaisala Sdn Bhd
Regional Office Malaysia
W11-A0, Level 11, West Block
Wisma Golden Eagle Realty
142-C Jalan Ampang
50450 Kuala Lumpur
MALAYSIA
www.vaisala.com

INDIA

Vaisala India Private Limited
Unit No # FOF/A/01, A Wing 4th Floor
Art Guild House
Phoenix Market City
L.B.S. Marg Kurla (West)
Mumbai 400 070
INDIA
www.vaisala.com

B212672EN-E © Vaisala – November 2025

This material is subject to copyright protection, with all copyrights retained by Vaisala and its individual partners. All rights reserved. Any logos and/or product names are trademarks of Vaisala or its individual partners. The reproduction, transfer, distribution or storage of information contained in this brochure in any form without the prior written consent of Vaisala is strictly prohibited. All specifications – technical included – are subject to change without notice.

VAISALA

Please contact us at
vaisala.com/requestinfo



vaisala.com/CMSCatalog