

# Product Catalog

Humidity · Temperature · Dew point · Carbon dioxide  
Biogas quality · Moisture in oil · Hydrogen peroxide  
Pressure · Liquid concentration · Weather · Service offering

## INDUSTRIAL INSTRUMENTS

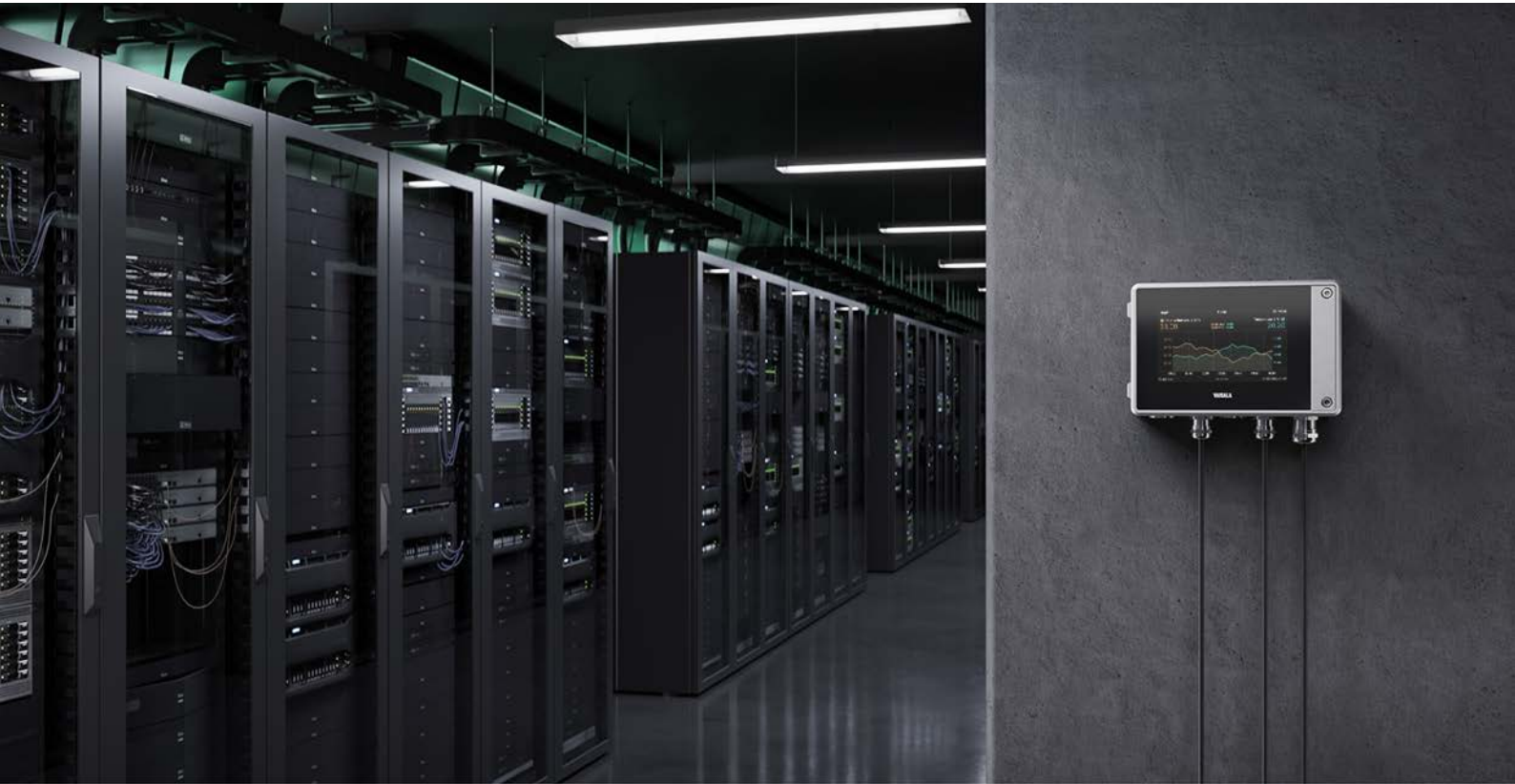

**VAISALA**

# Instruments and intelligence for industrial needs

## Vaisala Industrial Measurements

Vaisala's Industrial Measurements business area provides customers with visibility into their own processes. Our products provide them with accurate and reliable measurement data which enables them to make decisions for optimized industrial processes.

### Heating, ventilation, and air-conditioning (HVAC)

Vaisala offers industry benchmark HVAC transmitters for measuring humidity, temperature, and carbon dioxide indoors and outdoors. Customers use these instruments to optimize heating ventilation and air conditioning controls, for example, in offices, hospitals, data centers, factories, and cooling towers. Our transmitters help in maintaining good indoor air quality and saving costs through improved efficiency.

### Liquid measurements

Vaisala's cutting-edge Polaris™ process refractometers offer unparalleled reliability and performance in liquid concentration and density measurements for industrial manufacturing. Designed for seamless inline process control, our solutions are trusted across a wide range of demanding sectors, including pulp and paper, food and sugar production, semiconductors, pharmaceuticals, chemicals, oil refining, and petrochemicals.

### Life Cycle Services

Our Life Cycle Services provide comprehensive care through the life cycle of our measurement instruments. As a trusted partner to our global customers, we enable sustainable decisions by maintaining the most accurate measurement data throughout the entire product and system life cycle.

This product catalog provides an overview of our products to help you select what best suits your needs. For more information, visit us at [vaisala.com](https://vaisala.com) or contact us at [vaisala.com/requestinfo](https://vaisala.com/requestinfo). Product user documentation is available at [docs.vaisala.com](https://docs.vaisala.com).



# Table of contents

## INSIGHT PC SOFTWARE

Insight PC software for easy access to Indigo-compatible probes.....	7
--	---

## INDIGO TRANSMITTERS FOR SMART PROBES

<b>Indigo200</b> Series Transmitters for Vaisala Indigo-compatible probes.....	9
<b>Indigo300</b> Transmitter for Vaisala Indigo-compatible probes.....	11
<b>Indigo510</b> Transmitter for Vaisala Indigo-compatible probes.....	14
<b>Indigo520</b> Transmitter for Vaisala Indigo-compatible probes.....	17
<b>Indigo500MIK</b> Meteorological Installation Kit.....	21

## HANDHELDS FOR SPOT-CHECKING AND CALIBRATION

<b>Indigo80</b> Handheld Indicator for portable diagnostics.....	23
<b>HMP80</b> Series Handheld Humidity and Temperature Probes for spot-checking applications.....	26
<b>DMP80</b> Series Handheld Dew Point and Temperature Probes for spot-checking applications.....	29
<b>HM40</b> Series Handheld Humidity and Temperature Meter.....	32

## HUMIDITY AND TEMPERATURE

HUMICAP® humidity sensor for measuring relative humidity.....	36
How to select the right humidity instrument for your high-humidity application.....	38
Selecting the right filter for humidity instruments.....	43
<b>HMP1</b> Wall-Mounted Humidity and Temperature Probe.....	46
<b>HMP3</b> General Purpose Humidity and Temperature Probe.....	48
<b>HMP4</b> Relative Humidity and Temperature Probe for pressurized and vacuum processes.....	51
<b>HMP5</b> Relative Humidity and Temperature Probe for high temperatures.....	54
<b>HMP7</b> Relative Humidity and Temperature Probe for high humidities.....	57
<b>HMP8</b> Relative Humidity and Temperature Probe for pressurized and vacuum processes.....	60
<b>HMP9</b> Compact Humidity and Temperature Probe.....	63
<b>TMP1</b> Temperature Probe.....	66
<b>HMT370EX</b> Series Intrinsically Safe Humidity and Temperature Transmitters for operation in up to Zone 0 / 20.....	68
<b>HMT310</b> Series Humidity and Temperature Transmitters for demanding industrial applications.....	75
<b>HMT120</b> and <b>HMT130</b> Humidity and Temperature Transmitters.....	78
<b>TMT120</b> and <b>TMT130</b> Temperature Transmitters.....	81
<b>HMW90</b> Series Humidity and Temperature Transmitters for high-performance HVAC applications.....	84
<b>HMD60</b> Series Humidity and Temperature Transmitters for demanding HVAC and light industrial applications.....	87
<b>HMDW110</b> Series Humidity and Temperature Transmitters for high-accuracy measurements in HVAC applications.....	90
<b>TMI110</b> Temperature Transmitter for high-accuracy measurements in HVAC applications .....	93
<b>HMS110</b> Series Humidity and Temperature Transmitters for high-accuracy outdoor measurements in building automation applications.....	95
<b>HMDW80</b> Series Humidity and Temperature Transmitters for building automation applications.....	97
<b>HMS80</b> Series Humidity and Temperature Transmitters for outdoor measurements in building automation applications.....	102
<b>HMM100</b> Humidity Module for environmental chambers.....	104
<b>HMM105</b> Digital Humidity Module for OEM applications.....	106
<b>HMM170</b> Humidity and Temperature Module for environmental chambers.....	108

<b>HMP60</b> Humidity and Temperature Probe.....	110
<b>HMP63</b> Humidity and Temperature Probe .....	113
<b>HMP110</b> Humidity and Temperature Probe .....	116
<b>HMP113</b> Humidity and Temperature Probe .....	119
<b>SHM40</b> Structural Humidity Measurement Kit .....	122
<b>HMK15</b> Humidity Calibrator .....	125
<b>HMP155</b> Humidity and Temperature Probe .....	127
<b>DTR500</b> Solar Radiation and Precipitation Shields .....	129

## DEW POINT

DRYCAP® sensor for measuring humidity in dry conditions.....	131
<b>DMP1</b> Dew Point and Temperature Probe for dry rooms and cleanrooms.....	133
<b>DMP5</b> Dew Point and Temperature Probe for high-temperature applications.....	135
<b>DMP6</b> Dew Point Probe for very high-temperature applications.....	138
<b>DMP7</b> Dew Point and Temperature Probe for installations in tight spaces.....	140
<b>DMP8</b> Dew Point and Temperature Probe for pressurized pipelines.....	142
<b>DMT152</b> Dew Point Transmitter for low dew point measurement in OEM applications.....	145
<b>DMT143</b> Dew Point Transmitter for OEM applications.....	147
<b>DMT143L</b> Dew Point Transmitter for OEM applications (DMT242 replacement).....	150
<b>DMT132</b> Dew Point Transmitter for refrigerant dryers.....	152

## CARBON DIOXIDE

CARBOCAP® sensor for demanding environments.....	154
<b>MGP241</b> Multigas Probe for carbon dioxide and humidity measurement.....	156
<b>GMP343</b> Carbon Dioxide Probe for demanding measurements.....	159
<b>GMP231</b> Carbon Dioxide Probe for CO <sub>2</sub> incubators.....	162
<b>GMP251</b> Carbon Dioxide Probe for %-level measurements.....	164
<b>GMP252</b> Carbon Dioxide Probe for ppm-level measurements.....	167
<b>GMP80P</b> Portable Carbon Dioxide Probe With pump sampling.....	171
<b>GMW90</b> Series Carbon Dioxide, Temperature and Humidity Transmitters.....	174
<b>GMW80</b> Series Carbon Dioxide, Humidity, and Temperature Transmitters for DCV.....	177
<b>GMD110</b> Duct Carbon Dioxide Transmitter for demanding ventilation applications.....	180

## BIOGAS QUALITY

<b>MGP261</b> Multigas Probe for methane, carbon dioxide, and humidity measurement.....	182
<b>MGP262</b> Multigas Probe for low concentration methane and high concentration carbon dioxide measurement.....	184

## MOISTURE IN OIL

HUMICAP® sensor for measuring moisture in oil.....	186
<b>MMP8</b> Moisture in Oil Probe.....	188
<b>MMT310</b> Series Moisture and Temperature Transmitters for Oil.....	190

## HYDROGEN PEROXIDE

PEROXCAP® sensor for measuring vaporized hydrogen peroxide, relative saturation and relative humidity....	193
<b>HPP270</b> Series Probes for hydrogen peroxide, humidity, and temperature measurement.....	195

## PRESSURE

BAROCAP® sensor for measuring pressure.....	199
<b>Indigo520</b> Transmitter for Vaisala Indigo-compatible probes.....	201
<b>PTB330</b> Digital Barometer for professional meteorology, aviation, and industrial users.....	205

<b>PTB330TS</b> Barometric Pressure Transfer Standard for portable use.....	208
<b>PTB210</b> Digital Barometer.....	212
<b>PTB110</b> Barometer for industrial use.....	214
<b>SPH10/20</b> Static Pressure Heads for minimizing wind induced error.....	216
<b>PDT101</b> Differential Pressure Transmitter .....	218
<b>PDT102</b> Differential Pressure Transmitter.....	220

## LIQUID CONCENTRATION

Polaris™ <b>PR53AC</b> Sanitary Compact Process Refractometer.....	222
Polaris™ <b>PR53AP</b> Sanitary Probe Process Refractometer.....	228
Polaris™ <b>PR53GC</b> Compact Process Refractometer.....	233
Polaris™ <b>PR53GP</b> Probe Process Refractometer.....	237
Polaris™ <b>PR53M</b> PTFE-Body Process Refractometer.....	241
Polaris™ <b>PR53W</b> Valve-Body Process Refractometer.....	244
Polaris™ <b>PR53SD</b> Safe-Drive Process Refractometer.....	247
Polaris™ <b>PR53ACEX</b> Sanitary Compact Process Refractometer.....	250
Polaris™ <b>PR53APEX</b> Sanitary Compact Process Refractometer.....	254
Polaris™ <b>PR53GCEX</b> Compact Process Refractometer.....	259
Polaris™ <b>PR53GPEX</b> Probe Process Refractometer.....	263
Polaris™ <b>PR53MEX</b> PTFE-Body Process Refractometer.....	267
Polaris™ <b>PR53WEX</b> Valve-Body Process Refractometer.....	270

## WEATHER

Wind and weather sensor technologies for measurements in industrial applications .....	273
<b>WA15</b> Wind Set for high-performance wind measurement.....	275
<b>WMT700</b> Ultrasonic Wind Sensor Series .....	277
<b>WXT530</b> Weather Transmitter Series.....	279

## VAISALA SERVICE OFFERING

Service Center calibrations for instruments and data loggers.....	281
Vaisala contact information.....	282

## Indigo200 Series Transmitters For Vaisala Indigo-compatible probes



### Features

- Transmitter USB-C port allows connecting to Vaisala Insight PC software with a generic USB cable
- Numerical and graphical color display (optional non-display version for analog model)
- IP65 enclosure
- 24 V AC/DC power supply input
- Indigo201: 3 analog outputs (mA or V)
- Indigo202: RS-485 with Modbus® RTU
- 2 configurable relays

Vaisala Indigo200 series transmitters are host devices for displaying measurement values from Vaisala Indigo-compatible probes and transmitting measurements to automation systems through analog signals, Modbus RTU communication, or relays.

### Transmitter for Vaisala Indigo-compatible probes

- HMP series humidity and temperature probes HMP1, HMP3, HMP4, HMP5, HMP7, HMP8, HMP9
- TMP1 temperature probe
- DMP series dew point probes DMP5, DMP6, DMP7, DMP8
- GMP250 series CO<sub>2</sub> probes GMP251, GMP252
- HPP270 series vaporized hydrogen peroxide probes HPP271, HPP272
- MMP8 moisture in oil probe

Indigo200 series transmitters are plug-and-play probe host devices for current and future Vaisala Indigo-compatible probes. The host device has a color display with numeric and graph measurement viewing options; Indigo201 is also available as a non-display version that uses an LED indicator for notifications.

Vaisala Indigo-compatible probes are connected either directly to the host or by using a cable between Indigo200 and the probe.

The surface of the Indigo200 enclosure is smooth, which makes it easy to clean. It is also resistant to dust and most chemicals, such as H<sub>2</sub>O<sub>2</sub> and alcohol-based cleaning agents.

For easy access to configuration and monitoring options, Indigo200 can be connected to Vaisala Insight PC software using the USB-C port on the transmitter with any generic USB cable that has a USB-C connector.

With Insight PC software, you can configure both the host device and the probes connected to it. Insight PC software also provides options for temporary viewing of the measurement data and diagnostics.

For more information on Indigo transmitters and the Indigo product family, see [www.vaisala.com/indigo](http://www.vaisala.com/indigo).

# Technical data

## General

- Color display (Indigo201: optional non-display version)
- USB connection to Vaisala Insight PC software for easy access to configuration and monitoring options.

## Indigo-compatible probes

Measurement type	Probe models
Humidity and temperature	HMP1, HMP3, HMP4, HMP5, HMP7, HMP8, HMP9
Temperature	TMP1
Dew point	DMP1, DMP5, DMP6, DMP7, DMP8
Carbon dioxide	GMP251, GMP252
Vaporized hydrogen peroxide	HPP271, HPP272
Moisture in oil	MMP8

## Operating environment

Operating temperature	With display
	-20 ... +60 °C (-4 ... +140 °F)
	Without display
	-40 ... +60 °C (-40 ... +140 °F)
Storage temperature	-40 ... +70 °C (-40 ... +158 °F)
Chemical tolerance	Temporary exposure during cleaning:
	<ul style="list-style-type: none"> <li>• H<sub>2</sub>O<sub>2</sub> (6000 ppm, non-condensing)</li> <li>• Alcohol-based cleaning agents such as ethanol and IPA (max. 70 % concentrate)</li> </ul>
IP rating	IP65 <sup>1)</sup>
Indoor/outdoor use	Indoor use

<sup>1)</sup> Note that the IP65 rating only applies when the cable gland wiring option is used, and the lead-through with the pierceable seal at the back of the transmitter is left intact. See user documentation for more information on Indigo200 wiring options.

## Inputs and outputs

Insight PC software configuration access <sup>1)</sup>	USB-C port on transmitter (compatible with generic USB cables)
Power supply input	15–30 V DC <sup>2)</sup>
	24 V AC ±10 % 50/60 Hz
Relay contacts x 2	Max. switching current 1 A
	Max. switching voltage 40 V DC / 28 V AC
<b>Indigo201 model</b>	
Three analog outputs (voltage or current)	Voltage: 0–1 V, 0–5 V, 0–10 V, 1–5 V, scalable, min. load 1 kΩ
	Current: 4–20 mA, 0–20 mA, scalable, max. load 500 Ω
Accuracy of analog outputs at 20 °C	±0.1 % full scale for 0–10 V and 0–20 mA
<b>Indigo202 model</b>	
Digital communications	RS-485, Modbus RTU

<sup>1)</sup> Vaisala Insight software for Windows\* available at [www.vaisala.com/insight](http://www.vaisala.com/insight).

<sup>2)</sup> When used with the HMP7 probe, the minimum required power supply input is 18 V DC.

## Compliance

Electromagnetic compatibility (EMC)	EN 61326-1, industrial environment
Compliance marks	CE, RCM

## Mechanical specifications

Housing material	PC/ABS plastic
Display window material	PMMA plastic
Connection screw terminals	26–20 AWG
Weight	402 g (14.2 oz)
Dimensions (H×W×D)	149 × 135 × 43 mm (5.87 × 5.31 × 1.7 in)

## Spare parts and accessories

USB-C connection cable (2 m, type C to A, for Insight PC software access) <sup>1)</sup>	273956
Probe connection cable, 1 m (3 ft 3 in)	INDIGOCABLE1M
Probe connection cable, H <sub>2</sub> O <sub>2</sub> compatible, 1 m (3 ft 3 in)	INDIGOCABLEHDM5
Probe connection cable, 3 m (9 ft 11 in)	INDIGOCABLE3M
Probe connection cable, H <sub>2</sub> O <sub>2</sub> compatible, 3 m (9 ft 11 in)	INDIGOCABLEHDM3M
Probe connection cable, 5 m (16 ft 5 in)	INDIGOCABLE5M
Probe connection cable, H <sub>2</sub> O <sub>2</sub> compatible, 5 m (16 ft 5 in)	INDIGOCABLEHDM5M
Probe connection cable, 10 m (32 ft 10 in)	INDIGOCABLE10M
Probe connection cable, H <sub>2</sub> O <sub>2</sub> compatible, 10 m (32 ft 10 in)	INDIGOCABLEHDM10M
Universal mains power supply with EU/US/UK/AUS plugs	INDIGOPOWER24VSP

<sup>1)</sup> Note that a USB-C cable is not included in Indigo200 deliveries by default. A generic USB-C cable (type C to A) can also be used.

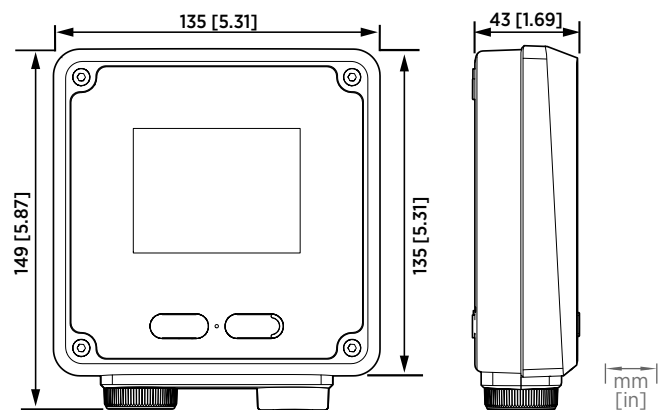

Indigo200 series dimensions

## Indigo300 Transmitter For Vaisala Indigo-compatible probes



### Features

- Numerical and graphical color display for up to 3 parameters
- Non-display version with an LED status indicator also available
- IP66-rated metal housing
- Support for one Indigo-compatible probe
- Tool-free locking wheel for the probe
- 24 V AC/DC power supply input
- 3 preconfigured analog outputs (mA or V)
- Service port for connecting to Vaisala Insight PC software or Indigo80 handheld indicator

Vaisala Indigo300 Transmitter is a host device for displaying measurement values from Vaisala Indigo-compatible probes and/or transmitting them to automation systems through analog signals.

### Transmitter for Vaisala Indigo-compatible probes

- HMP series humidity and temperature probes
- TMP1 temperature probe
- DMP series dew point probes
- GMP250 series carbon dioxide probes
- HPP270 series vaporized hydrogen peroxide probes
- MMP8 moisture in oil probe

The Indigo300 transmitter is a plug-and-play host device for current and future Vaisala Indigo-compatible probes. The transmitter has a numerical and graphical color display showing up to 3 measurement parameters simultaneously.

A non-display transmitter version with an LED status indicator is also available.

### Simple to connect and service

Probes can be connected to the transmitter tool-free using the locking wheel of the probe connector. You can connect a probe directly or by using a cable. Instead of the locking wheel and a detachable cable, it is also possible to use a cable gland with a fixed cable.

The service port on the front can be opened with a 4-mm Allen key for access to the free Vaisala Insight PC software or Indigo80 handheld indicator.

With Insight and Indigo80, you can view live measurement data from the probe connected to the transmitter, configure both the transmitter and the probe, as well as calibrate and adjust the probe without having to detach it from the transmitter.

### Robust design

The IP66-rated, corrosion-resistant metal housing of the transmitter is suitable for harsh conditions.

### Versatile installation options

The mounting options include mounting through the transmitter body and mounting on a DIN rail. With an adapter plate, the transmitter can be installed to replace an HMT330, DMT340, or MMT330 series transmitter.

The transmitter can either be wired from the back, which leaves no trailing cables, or through the bottom lead-throughs.

For more information on the Indigo300 transmitter and the Indigo product family, see [www.vaisala.com/indigo](http://www.vaisala.com/indigo).

# Technical data

## Indigo-compatible probes

Measurement type	Probe models
Humidity and temperature	HMP1, HMP3, HMP4, HMP5, HMP7, HMP8, HMP9
Temperature	TMP1
Dew point	DMP1, DMP5, DMP6, DMP7, DMP8
Carbon dioxide	GMP251, GMP252
Vaporized hydrogen peroxide	HPP271, HPP272
Moisture in oil	MMP8

## Operating environment

Operating temperature	With display: -20 ... +60 °C (-4 ... +140 °F) Without display: -40 ... +60 °C (-40 ... +140 °F)
Storage temperature	With display: -30 ... +70 °C (-22 ... +158 °F) Without display: -40 ... +70 °C (-40 ... +158 °F)
Operating humidity	0-100 %RH
Maximum operating altitude	5000 m (approx. 16 400 ft)
IP rating	IP66

## Inputs and outputs

Power supply input	15-30 V DC <sup>1)</sup> 24 V AC ±10 % 50/60 Hz
Fuse size for power supply	2.5 A
Transmitter service port connection	<ul style="list-style-type: none"> <li>Connection to Insight with USB2 and cable 262195SP <sup>2)</sup></li> <li>Connection to Indigo80 with cable 262195SP</li> </ul>
<b>Analog outputs</b>	Current or voltage
Number of analog outputs	3
Isolation	Not galvanically isolated
Selectable voltage output types	0-1 V, 0-5 V, 0-10 V, 1- 5 V, scalable, $R_L \geq 10 \text{ k}\Omega$
Selectable current output types	4-20 mA, 0-20 mA, scalable, $R_L \leq 500 \Omega$
Accuracy of analog outputs at 20 °C (+68 °F)	±0.1 % full scale <sup>3)</sup>
Temperature dependence	±0.005 % / °C full scale
<b>Current consumption at 20 °C (+68 °F) (<math>U_{in}</math> 24 V DC)</b>	
Minimum consumption with display off, no analog outputs active, no probe connected <sup>4)</sup>	13 mA
Minimum consumption with display on, brightness normal mode, no analog outputs active, no probe connected	18 mA
$U_{out}$ 0-1 V, 0-5 V, 0-10 V, 1-5 V	+ 1.8 mA per connected channel at maximum load
$I_{out}$ 4-20 mA, 0-20 mA	+ 12.3 mA max. per connected channel

1) When used with the HMP7 probe, the minimum required power supply input is 18 V DC.

2) Vaisala Insight software for Windows™ available at [vaisala.com/insight](http://vaisala.com/insight).

3) For the voltage outputs, small variation is possible around true zero.

4) For the current consumption of the connected probe, see the probe's user documentation at [docs.vaisala.com](http://docs.vaisala.com).

## Compliance

EU directives and regulations	EMC Directive (2014/30/EU) RoHS Directive (2011/65/EU) as amended by 2015/863
Electromagnetic compatibility (EMC)	EN IEC 61326-1, industrial environment
EMC emissions	CISPR 32 / EN 55032, Class A FCC part 15 B, Class A ICES-3 / NMB-3 (Class A)
Compliance marks	CE, China RoHS, FCC, KC, RCM, UKCA

## Mechanical specifications

Housing material	EN AW-6082
Connection screw terminals	Max. 1.5 mm <sup>2</sup> wire (16 AWG)
Cable lead-throughs for output and power cables	<ul style="list-style-type: none"> <li>M20×1.5 cable gland / conduit fitting NPT 1/2"</li> <li>M16×1.5 cable gland / conduit fitting NPT 1/2"</li> </ul>
Cable diameter for M20×1.5 gland	7-13 mm (0.26-0.51 in)
Cable diameter for M16×1.5 gland	2-6 mm (0.08-0.24 in)
Dimensions	161 × 134 × 43.5 mm (6.34 × 5.26 × 1.71 in)
Weight	1200 g (2.65 lb)

## Probe connection cables

Detachable cables for use with locking wheel	
Probe connection cable, 1 m (3 ft 3 in)	INDIGOCABLE1M
Probe connection cable, H <sub>2</sub> O <sub>2</sub> compatible, 1 m (3 ft 3 in)	INDIGOCABLEHD1M5
Probe connection cable, 3 m (9 ft 11 in)	INDIGOCABLE3M
Probe connection cable, H <sub>2</sub> O <sub>2</sub> compatible, 3 m (9 ft 11 in)	INDIGOCABLEHD3M
Probe connection cable, 5 m (16 ft 5 in)	INDIGOCABLE5M
Probe connection cable, H <sub>2</sub> O <sub>2</sub> compatible, 5 m (16 ft 5 in)	INDIGOCABLEHD5M
Probe connection cable, 10 m (32 ft 10 in)	INDIGOCABLE10M
Probe connection cable, H <sub>2</sub> O <sub>2</sub> compatible, 10 m (32 ft 10 in)	INDIGOCABLEHD10M
Fixed cables for use with cable gland	
Probe connection cable, 0.3 m (12 in), open end <sup>1)</sup>	CBL210896-03MSP
Probe connection cable, 1 m (3 ft 3 in), open end	CBL210896-1MSP
Probe connection cable, 3 m (9 ft 11 in), open end	CBL210896-3MSP
Probe connection cable, 5 m (16 ft 5 in), open end	CBL210896-5MSP
Probe connection cable, 10 m (32 ft 10 in), open end	CBL210896-10MSP

1) The usable length outside of the transmitter enclosure is approx. 0.1 m (4 in) shorter than the total length of the cable.

## Spare parts and accessories

Adapter plate for replacing a Vaisala 330 series transmitter	DRW257715SP
DIN rail installation kit for 35 mm (0.11 in) wide DIN rail	ASM215071SP
Vaisala Indigo USB adapter and M12 - M8 service cable, for connecting to Insight	USB2 and 262195SP
M12 - M8 service cable 1.5 m (4.9 ft), for connecting to Indigo80	262195SP
Cable gland M20×1.5 for 7.0–13.0 mm (0.26–0.51 in) cable	253993SP
Conduit fitting M20×1.5 for NPT1/2" conduit	214780SP
Cable gland M16×1.5 for 2.0–6.0 mm (0.08–0.24 in) cable	ASM213671SP
Conduit fitting M16×1.5 for NPT1/2" conduit	210675SP
Plug for M20 lead-through	ASM213672SP
Plug for M16 lead-through	210369SP
Service port plug	DRW257660SP

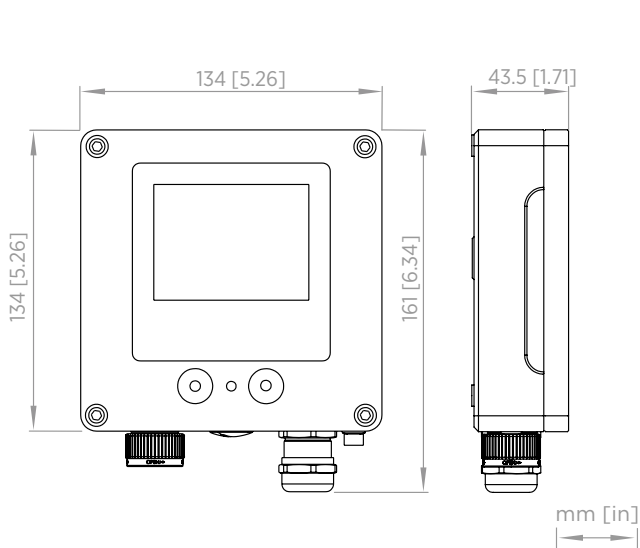

Indigo300 transmitter dimensions

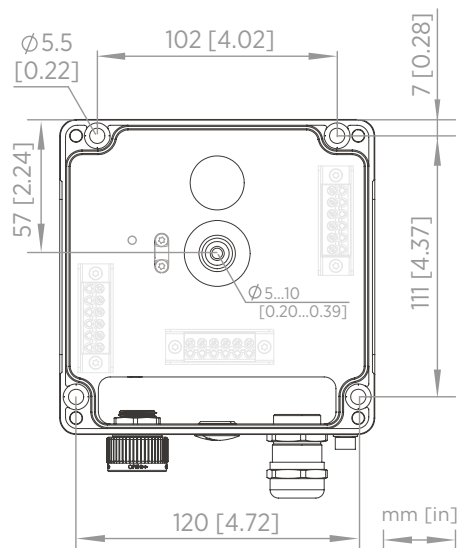

Indigo300 transmitter body mounting dimensions

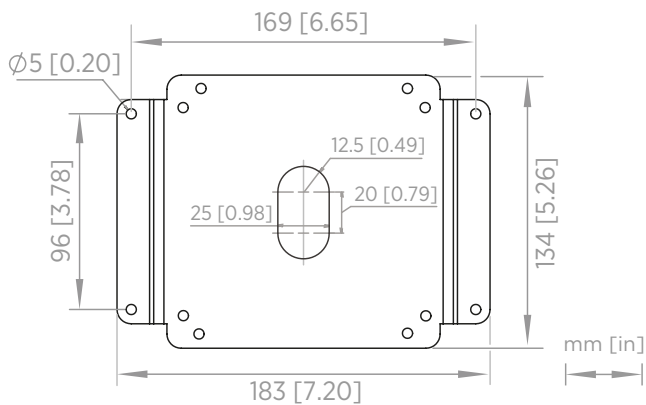

Indigo300 adapter plate (DRW257715SP) mounting dimensions

## Indigo510 Transmitter

For Vaisala Indigo-compatible probes



### Features

- Touchscreen display (optional non-display model with LED indicator also available)
- Data logging of all measurement parameters
- IP66 rated metal enclosure
- 2 configurable galvanically isolated analog outputs
- Ethernet connection with web interface and optional Vaisala cloud connectivity for remote monitoring
- Modbus<sup>®</sup> TCP/IP protocol
- Protective extra-low voltage powering
- UL Listed in USA and Canada

Vaisala Indigo510 Transmitter is an industrial-grade, robust transmitter that accommodates 1 Vaisala Indigo-compatible probe for humidity, temperature, dew point, carbon dioxide, hydrogen peroxide, and moisture in oil measurements. The transmitter can display measurements on the spot as well as transmit them to automation systems through analog signals or Modbus TCP/IP protocol.

### Variety of probe options

The Indigo500 series transmitters are the most versatile option for use with Indigo-compatible probes.

- HMP series humidity and temperature probes
- DMP series dew point probes
- GMP250 series carbon dioxide probes
- HPP270 series vaporized hydrogen peroxide probes
- MMP8 moisture in oil probe

The probes are interchangeable, self-contained measurement instruments that are easily detachable from the transmitter for calibration and maintenance. The probes are connected using a cable that can be extended with a standard instrumentation cable to allow up to 30 m (98 ft) distance between the transmitter and the probe. The Indigo500 series transmitters can be connected to the MHT410 transmitter for display of measurement data and automation system connectivity.

Through the transmitter service port, the Indigo500 series transmitters can also be connected to the free Vaisala Insight PC Software or Indigo80 Handheld Indicator.

For more information on the Indigo product family, see [vaisala.com/indigo](https://vaisala.com/indigo).

### Analog and digital interfaces

The Indigo510 transmitter has 2 analog channels that can be configured to mA or voltage type. Any of the output parameters from the connected probe can be assigned to control the analog channels.

The digital output protocol is Modbus TCP/IP over Ethernet. The Ethernet connection also provides a web interface and cybersecurity that meets modern standards. The Indigo500 series transmitters can be ordered with a possibility for Vaisala cloud connection for remote monitoring.

### Robust design

The transmitter has a wide operating temperature range, an IP66-rated corrosion-resistant metal enclosure, and an optional touchscreen display made of strengthened (IK08) glass.

The transmitter withstands commonly used cleaning chemicals, such as isopropanol and liquid H<sub>2</sub>O<sub>2</sub> (30 %), and performs even in the harshest conditions. The standard mounting options include mounting on a wall and on a DIN rail. With a retrofit mounting plate, the transmitter can be installed to replace an HMT330, DMT340, or MMT330 series transmitter. A pole mounting kit is also available as an accessory.

# Technical data

## Indigo-compatible probes

Measurement type	Probe models
Humidity and temperature	HMP1, HMP3, HMP4, HMP5, HMP7, HMP8, HMP9
Temperature	TMP1
Dew point	DMP1, DMP5, DMP6, DMP7, DMP8
Carbon dioxide	GMP251, GMP252
Vaporized hydrogen peroxide	HPP271, HPP272
Moisture in oil	MMP8

## Other compatible devices

Device or series	Models
Moisture, Hydrogen and Temperature Transmitter MHT410	MHT410
Indigo80 Handheld Indicator	Indigo80

## Transmitter options

Display	<ul style="list-style-type: none"> <li>Capacitive touchscreen display</li> <li>No display (indicator LED)<sup>1)</sup></li> </ul>
Powering	Protective extra-low voltage (11–35 V DC, 24 V AC ± 20 % 50/60 Hz)

1) Recommended when the transmitter is exposed to direct UV light, and for outdoor installations and high-humidity environments.

## Mechanical specifications

Housing classification	IK08, DIN EN ISO 11997-1: Cycle B (VDA 621-415)
Housing material	AlSi10Mg (DIN 1725)
Display window material	Strengthened glass (IK08)
Weight	1.5 kg (3.3 lb)
Dimensions (H × W × D)	142 × 182 × 67 mm (5.63 × 7.17 × 2.64 in)

### Cable diameters for cable glands

M20×1.5 glands	5.0–9.0 mm (0.20–0.35 in)
M20×1.5 glands with split bushing	7 mm (0.28 in)
M16×1.5 glands	2.0–6.0 mm (0.08–0.24 in)

## Operating environment

Operating environment	Outdoor use
Use in wet location	Yes
Operating humidity	0–100 %RH
Maximum operating altitude	4000 m (approx. 13 100 ft)
IP rating	IP66 <sup>1)</sup>
UL 50E rating	Type 4

### Operating temperature

With display	–20 ... +60 °C (–4 ... +140 °F)
Without display	–40 ... +60 °C (–40 ... +140 °F)

### Storage temperature

With display	–30 ... +60 °C (–22 ... +140 °F)
Without display	–40 ... +60 °C (–40 ... +140 °F)

1) Evaluated by Eurofins, not by UL.

## Powering

Operating power	
Protective extra-low voltage (PELV)	11–35 V DC, 24 V AC ±20 % 50/60 Hz, max. current 2 A (power supply is galvanically isolated) <sup>1)</sup>
	Fuse size for power supply: 3 A
	Isolation voltage: 500 V AC, 1000 V DC
PELV power cable temp. rating	≥ +80 °C (+176 °F)

### Typical current consumption at +20 °C (+68 °F) (U<sub>in</sub> 24 V DC)<sup>2)</sup>

Base consumption (no display, analog outputs, or communication)	50 mA
With display	+ 60 mA
With voltage analog output	< 2 mA per channel
With current analog output	+ 21 mA per channel
With Ethernet cable connected	+ 15 mA

1) The DNV type approval is valid in operating voltage range 15–35 V DC.

2) For the current consumption of the connected measurement device, see the device's documentation, available at docs.vaisala.com.

## Inputs and outputs

Transmitter service port connection	<ul style="list-style-type: none"> <li>Connection to Insight software with USB2 and cable 262195SP or with cable 219690<sup>1)</sup></li> <li>Connection to Indigo80 with cable 262195SP</li> </ul>
-------------------------------------	---

### Analog outputs

Number of analog outputs	2
Isolation	Isolated from power supply
Selectable voltage output types	0–1 V, 0–5 V, 0–10 V, scalable
Selectable current output types	4–20 mA, 0–20 mA, scalable
Max. wire size	2.5 mm <sup>2</sup> (14 AWG)
Accuracy of analog outputs at +20 °C (+68 °F)	±0.05 % full scale
Temperature dependence	±0.005 % / °C full scale

### External loads:

Current outputs	R <sub>L</sub> < 500 Ω
0–1 V output	R <sub>L</sub> > 2 kΩ
0–5 V and 0–10 V outputs	R <sub>L</sub> > 10 kΩ

### Ethernet interface

Supported standards	10BASE-T, 100BASE-TX
Connector	8P8C (RJ45)
Supported protocols	Modbus TCP/IP (port 502), HTTPS (port 8443)
Vaisala cloud connectivity <sup>2)</sup>	Requires outbound TCP port 443 and UDP port 123

1) Vaisala Insight PC Software for Windows® available at vaisala.com/insight.

2) Available only for transmitters ordered with software configuration for Vaisala cloud connectivity.

## User interfaces

User interfaces	Web interface, optional touchscreen display, optional Vaisala cloud connectivity for remote monitoring <sup>1)</sup>
Supported languages	English, Chinese (simplified), Chinese (traditional), French, German, Japanese, Spanish
Optional display	5" capacitive touchscreen
Integrated data logging capabilities	Non-volatile memory, at least 10 years' storage with 24 h interval logging

<sup>1)</sup> Available only for transmitters ordered with software configuration for Vaisala cloud connectivity.

## Compliance

EU directives and regulations	EMC Directive (2014/30/EU) RoHS Directive (2011/65/EU) as amended by 2015/863
Electromagnetic compatibility (EMC)	IEC/EN 61326-1, industrial environment CISPR 32 / EN 55032, Class B
Electrical safety	IEC/EN 61010-1
Type approvals	DNV GL certificate no. TAA000032M EU RO Mutual Recognition certificate no. MRA000004F
Compliance marks	CE, China RoHS, FCC, RCM, UKCA
Listing marks	UL Listed (USA and Canada)
FCC compliance	FCC Part 15, Class B

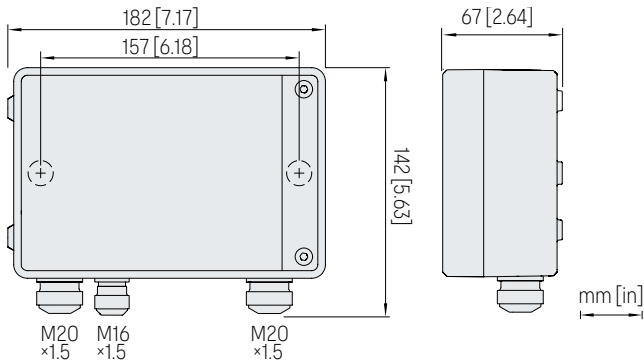

Indigo510 dimensions and lead-through sizes

## Spare parts

Cable gland, M20×1.5, 5.0–9.0 mm (0.20–0.35 in)	ASM213670SP
Cable gland with split bushing, M20×1.5 <sup>1)</sup>	262632SP
Cable gland, M16×1.5, 2.0–6.0 mm (0.08–0.24 in)	ASM213671SP
Conduit fitting, M20×1.5 for NPT1/2" conduit	214780SP

<sup>1)</sup> With 7-mm (0.28 in) hole for cable and 14-mm (0.55 in) hole for 8P8C (RJ45) connector to pass through.

## Accessories

Retrofit mounting plate	DRW252186SP
Installation kit for pole or pipeline	215108
Installation kit with weather shield	215109
Indigo500 spatter guard	ASM214526
M12 - M8 service cable 1.5 m (4.9 ft), for connecting to Indigo80	262195SP
Vaisala Indigo USB adapter and M12 - M8 service cable, for connecting to Insight software	USB2 and 262195SP
M8 - USB service cable, for connecting to Insight software	219690

### Probe connection cables

Probe connection cable, 0.3 m (approx. 12 in), open end <sup>1)</sup>	CBL210896-03MSP
Probe connection cable, 1 m (approx. 3 ft 3 in), open end <sup>1)</sup>	CBL210896-1MSP
Probe connection cable, 3 m (approx. 9 ft 10 in), open end <sup>1)</sup>	CBL210896-3MSP
Probe connection cable, 5 m (approx. 16 ft 5 in), open end <sup>1)</sup>	CBL210896-5MSP
Probe connection cable, 10 m (approx. 32 ft 10 in), open end <sup>1)</sup>	CBL210896-10MSP

<sup>1)</sup> The usable length outside of the transmitter enclosure is approx. 0.1 m (4 in) shorter than the total length of the cable.

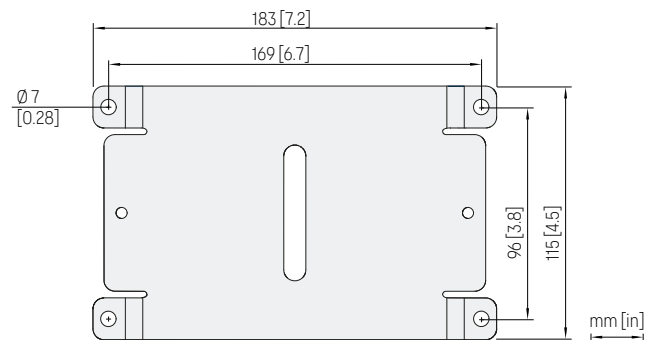

Indigo500 retrofit mounting plate dimensions

## Indigo520 Transmitter For Vaisala Indigo-compatible probes



### Features

- Supports 2 detachable measurement devices simultaneously
- Data logging of all measurement parameters
- IP66 rated metal enclosure
- 4 configurable galvanically isolated analog outputs
- 2-wire current loop analog input
- 2 relays
- Ethernet connection with web interface and optional Vaisala cloud connectivity for remote monitoring
- Displays measurements on the spot and transmits them to automation systems through analog signals, relays, or Modbus TCP/IP protocol

Vaisala Indigo520 Transmitter is an industrial-grade, robust transmitter that accommodates 1 or 2 Vaisala Indigo-compatible probes for humidity, temperature, dew point, carbon dioxide, hydrogen peroxide, and moisture in oil measurements. The transmitter can measure barometric pressure with an additional module.

### Options

- Multiple powering options: Power over Ethernet, protective extra-low voltage, and AC (mains) power
- Available with Vaisala BAROCAP® barometric pressure sensor known for its high accuracy and excellent long-term stability
- Optional non-display model with LED indicator

### Variety of probe options

The Indigo500 series transmitters are the most versatile option for use with Indigo-compatible probes.

- HMP series humidity and temperature probes
- DMP series dew point probes
- GMP250 series carbon dioxide probes

- HPP270 series vaporized hydrogen peroxide probes
- MMP8 moisture in oil probe

The probes are interchangeable, self-contained measurement instruments that are easily detachable from the transmitter for calibration and maintenance. The probes are connected using a cable that can be extended with a standard instrumentation cable to allow up to 30 m (98 ft) distance between the transmitter and the probe.

The Indigo500 series transmitters can be connected to the MHT410 transmitter for display of measurement data and automation system connectivity. Through the transmitter service port, the Indigo500 series transmitters can also be connected to the free Vaisala Insight PC Software or Indigo80 Handheld Indicator.

The Indigo520 transmitter can be connected to Polaris™ PR53 Process Refractometers for measuring liquid concentrations.

For more information on the Indigo product family, see [vaisala.com/indigo](https://vaisala.com/indigo).

### Analog and digital interfaces

The Indigo520 transmitter has 4 analog channels that can be configured to mA or voltage type, and 2 configurable relays. Any of the output parameters from the connected probes can be assigned to control the analog channels and relays.

The digital output protocol is Modbus TCP/IP over Ethernet. The Ethernet connection also provides a web interface and cybersecurity that meets modern standards. The Indigo500 series transmitters can be ordered with a possibility for Vaisala cloud connection for remote monitoring.

# Technical data

## Indigo-compatible probes

Measurement type	Probe models
Humidity and temperature	HMP1, HMP3, HMP4, HMP5, HMP7, HMP8, HMP9
Temperature	TMP1
Dew point	DMP1, DMP5, DMP6, DMP7, DMP8
Carbon dioxide	GMP251, GMP252
Vaporized hydrogen peroxide	HPP271, HPP272
Moisture in oil	MMP8

## Other compatible devices

Device or series	Models
Moisture, Hydrogen and Temperature Transmitter MHT410	MHT410
Polaris™ Process Refractometers <sup>1)</sup>	PR53AC, PR53AP, PR53GC, PR53GP, PR53M, PR53SD, PR53W
Indigo80 Handheld Indicator	Indigo80
MGP241 Multigas Probe	MGP241
MGP260 Series Multigas Probes	MGP261, MGP262
Differential Pressure Transmitters <sup>2)</sup>	PDT101, PDT102

<sup>1)</sup> Compatible with transmitters ordered with software configuration "L" for process refractometers.  
<sup>2)</sup> PDT101 and PDT102 can be used through analog input.

## Transmitter options

Display	<ul style="list-style-type: none"> <li>Capacitive touchscreen display</li> <li>No display (indicator LED) <sup>1)</sup></li> </ul>
Powering	<ul style="list-style-type: none"> <li>Protective extra-low voltage (15–35 V DC, 24 V AC ± 20%)</li> <li>AC (mains) power (100–240 V AC 50/60 Hz)</li> <li>Power over Ethernet (no analog outputs, analog input, or relays)</li> </ul>

<sup>1)</sup> Recommended when the transmitter is exposed to direct UV light, and for outdoor installations and high-humidity environments.

## Measurement performance

Barometric pressure (optional module)	
Pressure range	500–1100 hPa
Class A:	
Linearity	±0.05 hPa
Hysteresis	±0.03 hPa
Repeatability	±0.03 hPa
Calibration uncertainty	±0.07 hPa
Accuracy at +20 °C / +68 °F	±0.10 hPa
Temperature dependence	±0.1 hPa
Total accuracy (-40 ... +60 °C / -40 ... +140 °F)	±0.15 hPa
Long-term stability/year	±0.1 hPa
Response time (100 % response):	
One sensor	2 s
Pressure units	hPa, mbar, kPa, Pa, inHg, mmH2O, mmHg, torr, psia

## Mechanical specifications

Housing classification	IK08, DIN EN ISO 11997-1: Cycle B (VDA 621-415)
Housing material	AlSi10Mg (DIN 1725)
Display window material	Strengthened glass (IK08)
Weight	1.5 kg (3.3 lb)
Dimensions (H × W × D)	142 × 182 × 67 mm (5.63 × 7.17 × 2.64 in)

### Cable diameters for cable glands

M20×1.5 glands	5.0–9.0 mm (0.20–0.35 in)
M20×1.5 glands with split bushing	7 mm (0.28 in)
M16×1.5 glands	2.0–6.0 mm (0.08–0.24 in)

## Operating environment

Operating environment	Outdoor use
Use in wet location	Yes
Operating humidity	0–100 %RH
Maximum operating altitude, AC (mains) power	3000 m (approx. 9800 ft)
Maximum operating altitude, protective extra-low voltage (PELV) and Power over Ethernet (PoE)	4000 m (approx. 13 100 ft)
IP rating	IP66 <sup>1)</sup>
UL 50E rating	Type 4

### Operating temperature

With display	-20 ... +55 °C (-4 ... +131 °F)
Without display	-40 ... +60 °C (-40 ... +140 °F)
Without display with barometer module	-40 ... +55 °C (-40 ... +131 °F)

### Storage temperature

With display	-30 ... +60 °C (-22 ... +140 °F)
Without display	-40 ... +60 °C (-40 ... +140 °F)

<sup>1)</sup> Evaluated by Eurofins, not by UL.

## Powering

### Operating power <sup>1)</sup>

Protective extra-low voltage (PELV) version 15–35 V DC, 24 V AC  $\pm 20\%$  50/60 Hz, max. current 2 A (power supply is galvanically isolated)

Fuse size for power supply: 3 A

Isolation voltage: 500 V AC, 1000 V DC

PELV power cable temp. rating  $\geq +80\text{ }^\circ\text{C}$  (+176  $^\circ\text{F}$ )

AC (mains) power version 100–240 V AC 50/60 Hz, max. current 1 A (power supply is galvanically isolated)

Fuse size for power supply: 10 A

Isolation voltage: 1500 V AC

AC (mains) power cable length 2.5 m (approx. 8 ft 2 in)

Power over Ethernet version Power over Ethernet (PoE) IEEE 802.3at Type 2 Class 4  
Max. current 600 mA, max. power consumption 25.5 W  
Isolation voltage: 500 V AC, 1000 V DC

### Typical current consumption at +20 $^\circ\text{C}$ (+68 $^\circ\text{F}$ ) ( $U_{in}$ 24 V DC) <sup>2)</sup>

Base consumption (no display, analog outputs, or communication) 50 mA

With display + 60 mA

With voltage analog output < 2 mA per channel

With current analog output + 21 mA per channel

With relays + 9 mA per relay

With Ethernet cable connected + 15 mA

With barometer module + 5 mA

<sup>1)</sup> The power supply option is selected when ordering the transmitter.

<sup>2)</sup> For the current consumption of the connected measurement device, see the device's documentation, available at [docs.vaisala.com](https://docs.vaisala.com).

## User interfaces

User interfaces Web interface, optional touchscreen display, optional Vaisala cloud connectivity for remote monitoring <sup>1)</sup>

Supported languages English, Chinese (simplified), Chinese (traditional), French, German, Japanese, Spanish

Optional display 5" capacitive touchscreen

Integrated data logging capabilities Non-volatile memory, at least 10 years' storage with 24 h interval logging

## Inputs and outputs

Transmitter service port connection

- Connection to Insight software with USB2 and cable 262195SP or with cable 219690 <sup>1)</sup>
- Connection to Indigo80 with cable 262195SP

### Analog input <sup>2)</sup>

Available ranges 4–20 mA

Resolution 6  $\mu\text{A}$

Display resolution 0.01 mA

Accuracy  $\pm 0.05\text{ mA}$

Input impedances 200  $\Omega$

Isolation Isolated from power supply

Overload protection 40 mA max. (reverse polarity protected)

### Analog outputs <sup>2)</sup>

Number of analog outputs 4

Isolation Isolated from power supply

Selectable voltage output types 0–1 V, 0–5 V, 0–10 V, scalable

Selectable current output types 4–20 mA, 0–20 mA, scalable

Max. wire size 2.5 mm<sup>2</sup> (14 AWG)

Accuracy of analog outputs at +20  $^\circ\text{C}$  (+68  $^\circ\text{F}$ )  $\pm 0.05\%$  full scale

Temperature dependence  $\pm 0.005\%$  /  $^\circ\text{C}$  full scale

External loads:

Current outputs  $R_L < 500\ \Omega$

0–1 V output  $R_L > 2\ \text{k}\Omega$

0–5 V and 0–10 V outputs  $R_L > 10\ \text{k}\Omega$

### Relay outputs <sup>2)</sup>

Number and type of relays 2 pcs, SPDT

Max. switching power, current, voltage 30 W, 1 A, 40 V DC / 28 V AC

Max. wire size in PELV version 2.5 mm<sup>2</sup> (14 AWG)

Max. wire size in AC (mains) version 1.5 mm<sup>2</sup> (16 AWG)

### Ethernet interface

Supported standards 10BASE-T, 100BASE-TX

Connector 8P8C (RJ45)

Supported protocols Modbus TCP/IP (port 502), HTTPS (port 8443)

Vaisala cloud connectivity <sup>3)</sup> Requires outbound TCP port 443 and UDP port 123

<sup>1)</sup> Vaisala Insight PC Software for Windows® available at [vaisala.com/insight](https://vaisala.com/insight).

<sup>2)</sup> Not available in transmitters that are powered with Power over Ethernet (PoE).

<sup>3)</sup> Available only for transmitters ordered with software configuration for Vaisala cloud connectivity.

## Compliance

EU directives and regulations EMC Directive (2014/30/EU)  
Low Voltage Directive (2014/35/EU)  
RoHS Directive (2011/65/EU) as amended by 2015/863

Electromagnetic compatibility (EMC) IEC/EN 61326-1, industrial environment  
CISPR 32 / EN 55032, Class B

Electrical safety IEC/EN 61010-1

Type approvals DNV GL certificate no. TAA000032M  
EU RO Mutual Recognition certificate no. MRA000004F

Compliance marks CE, China RoHS, FCC, RCM, UKCA

Listing marks UL Listed (USA and Canada)

FCC compliance FCC Part 15, Class B



## Spare parts

Cable gland, M20×1.5, 5.0–9.0 mm (0.20–0.35 in)	ASM213670SP
Cable gland, M20×1.5, 10.0–14.0 mm (0.39–0.55 in)	ASM215414
Cable gland with split bushing, M20×1.5 <sup>1)</sup>	262632SP
Cable gland, M16×1.5, 2.0–6.0 mm (0.08–0.24 in)	ASM213671SP
Conduit fitting, M20×1.5 for NPT1/2" conduit	214780SP
Sintered filter (for barometer module)	DRW010335SP

## Accessories

Retrofit mounting plate	DRW252186SP
Installation kit for pole or pipeline	215108
Installation kit with weather shield	215109
Indigo500 spatter guard	ASM214526
M12 - M8 service cable 1.5 m (4.9 ft), for connecting to Indigo80	262195SP
Vaisala Indigo USB adapter and M12 - M8 service cable, for connecting to Insight software	USB2 and 262195SP
M8 - USB service cable, for connecting to Insight software	219690

### Probe connection cables

Probe connection cable, 0.3 m (approx. 12 in), open end <sup>1)</sup>	CBL210896-03MSP
Probe connection cable, 1 m (approx. 3 ft 3 in), open end <sup>1)</sup>	CBL210896-1MSP
Probe connection cable, 3 m (approx. 9 ft 10 in), open end <sup>1)</sup>	CBL210896-3MSP
Probe connection cable, 5 m (approx. 16 ft 5 in), open end <sup>1)</sup>	CBL210896-5MSP
Probe connection cable, 10 m (approx. 32 ft 10 in), open end <sup>1)</sup>	CBL210896-10MSP

<sup>1)</sup> The usable length outside of the transmitter enclosure is approx. 0.1 m (4 in) shorter than the total length of the cable.

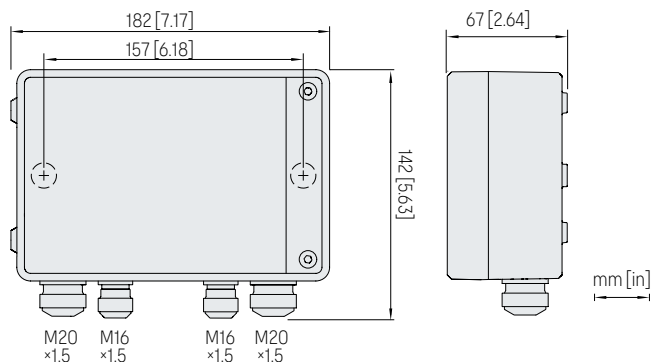

Indigo520 dimensions and lead-through sizes

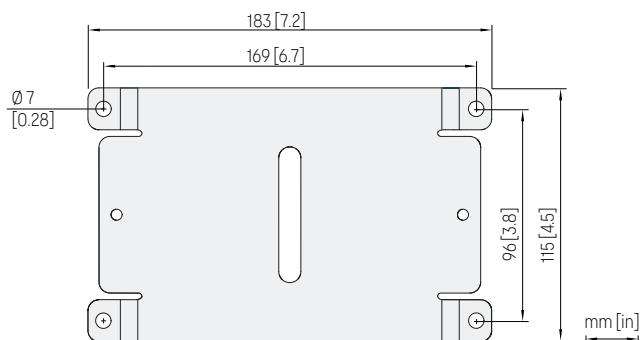

Indigo500 retrofit mounting plate dimensions



### Features

- Outdoor installation kit for Indigo500 Series transmitters
- Supports wall and pole mounting
- Delivered pre-assembled according to selected options
- DTR502 Solar Radiation Shield option prevents temperature measurement error
- DTS1 Weather Shield option prevents a microclimate from forming around a heated probe
- SPH10 Static Pressure Head option eliminates pressure variations caused by wind

The Indigo500MIK Meteorological Installation Kit enables Vaisala Indigo500 Series transmitters to obtain professional grade outdoor measurements of environmental parameters. The kit is delivered pre-assembled with the selected options, with or without measurement equipment.

### Essential for critical weather measurements

Outdoor installation of measurement instruments must be done properly to avoid common sources of measurement error, and to ensure long service life. The Indigo500MIK Meteorological Installation Kit is designed to enable Indigo500 Series transmitters and compatible measurement probes to obtain reliable measurements in challenging weather conditions. The kit is recommended for use with the HMP3 and HMP7 humidity and temperature probes, and the TMP1 temperature probe.

### True humidity readings in condensing conditions

In weather observations dew formation makes reliable humidity measurement difficult. When dew has formed on the humidity sensor, it is impossible to obtain a true reading until the dew evaporates. Obtaining a true humidity

reading is particularly important in traffic safety, at airports, and at sea. It is essential, for example, in fog and frost prediction.

Combining an Indigo500 Series transmitter with a HMP7 and TMP1 probes provides a solution to the problem. HMP7 utilizes probe heating for condensation prevention. When the probe head is heated, risk of dew formation on the sensor is greatly reduced. When combined with accurate temperature measurement from TMP1 probe, the Indigo500 transmitter can calculate the ambient relative humidity precisely in all conditions.

### Open shield prevents microclimates

Traditional solar radiation shields are not optimal for use with heated probes, as sleet or snow can accumulate on the shield. This may prevent proper air circulation and create a humid microclimate around the probe head until the snow melts.

DTS1 Weather Shield option provides the heated HMP7 probe with appropriate protection that prevents the formation of a microclimate. The shield is open at the bottom to ensure steady air circulation to the sensor even in calm weather.



For calibration, a portable HMP77 reference probe is easy to attach beside the HMP7 probe head.

# Technical data

DTR502 Solar Radiation Shield (option) for humidity and temperature probes

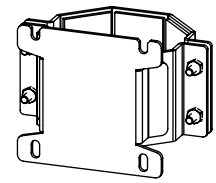
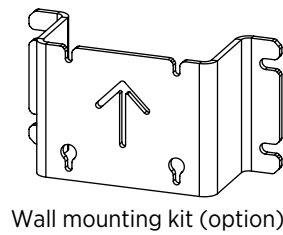

Pole mounting kit (option)  
up to Ø 100 mm (3.9 in)

Rain shield for transmitter

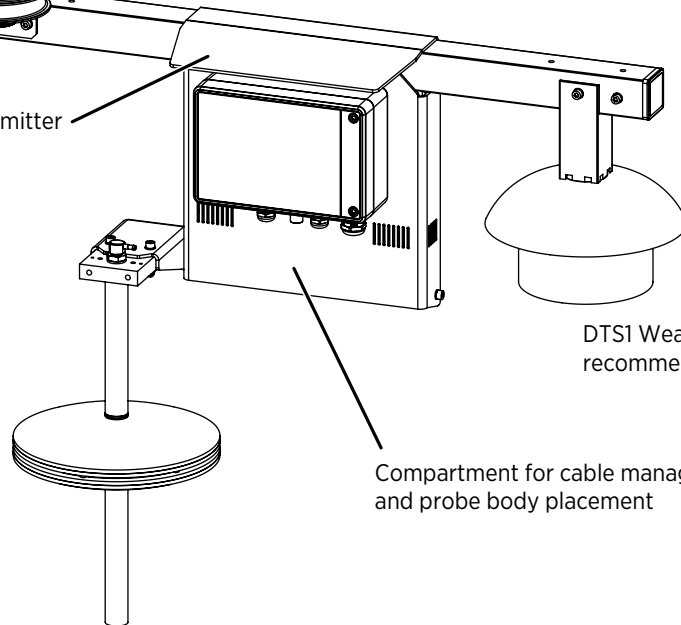

DTS1 Weather Shield (option)  
recommended with warmed probe

Compartment for cable management  
and probe body placement

SPH10 Static Pressure Head (option)  
for minimizing the effect of wind  
on pressure measurement

## Specifications

Compatible transmitters	Indigo510, Indigo520, HMT370EX
Compatible solar radiation shields	DTR502, DTR13, DTR250
Weather shield for heated probe	DTS1 <sup>1)</sup>
Static pressure head	SPH10 <sup>1)</sup>
Weight of mounting plate, probe compartment, and support bar	1.5 kg (3.3 lb)
Material of mounting plate, probe compartment, and support bar	Anodized marine grade aluminum

<sup>1)</sup> Attachment requires an adapter that is included when ordering the mounting kit with this option.

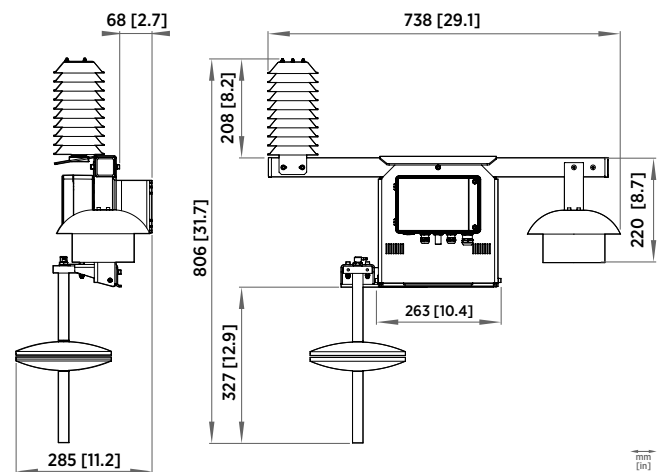

Indigo500MIK dimensions with wall mounting kit









### Features

- Flexible operation with Vaisala Indigo family measurement probes and other supported Vaisala devices
- Complemented by the HMP80 and DMP80 handheld probes and the GMP80P probe with pump sampling, which are optimized for portable use cases
- Intuitive user interface available in 10 languages
- Rechargeable battery
- Robust design and modern appearance
- Logged measurement data can be transferred to PC via Vaisala Insight software

Vaisala Indigo80 Handheld Indicator is an industrial-grade portable diagnostics tool. Accommodating up to two Vaisala devices, Indigo80 is ideal for spot-checking and process monitoring, as well as for configuring, troubleshooting, calibrating, and adjusting Indigo family measurement probes and other supported Vaisala devices.

### Seamless compatibility for varied measurements

The Indigo80 indicator has two cable ports by which a combination of two compatible measurement devices can be simultaneously connected to the indicator. Indigo80 can communicate with most current and future Vaisala devices for measuring a wide range of parameters.

-  Humidity and temperature
-  Dew point
-  Carbon dioxide
-  Hydrogen peroxide vapor
-  Moisture in oil
-  Liquid concentration

For the full set of Vaisala devices currently compatible with Indigo80, see the following page. For more information on the Indigo product family, see [vaisala.com/indigo](https://vaisala.com/indigo).

### Robust and reliable

The sturdy aluminum body of Indigo80 is resistant to chemicals and dust. Indigo80 is powered by a rechargeable lithium-ion battery with a typical operation time of 10 h. During long-term logging Indigo80 can be powered by using an AC adapter.

### Easy to use

Indigo80 has an intuitive user interface that guides the user if needed. The indicator is designed to be easy to use in numerous use cases and measurement environments.

To access logged data and configuration functionality, Indigo80 can be connected to Vaisala Insight PC software for Windows®. For more information, see [vaisala.com/insight](https://vaisala.com/insight).

### Multilingual user interface

Indigo80 has a multilingual, menu-based user interface that shows live measurement data both numerically and graphically. The Indigo80 user interface is available in 10 languages.



View live measurement data as numbers or graphs

# Vaisala devices compatible with Indigo80

Vaisala devices with older firmware versions may have limited compatibility with the Indigo80 indicator. For the most up-to-date version compatibility information, see [Firmware version compatibility of Indigo80-compatible devices Technical Note \(M212901EN\)](#), available at [docs.vaisala.com](https://docs.vaisala.com).

## Vaisala Indigo-compatible probes

HMP1, HMP3, HMP4, HMP5, HMP7, HMP8, HMP9, HMP80L, HMP80N	Humidity and temperature
TMP1	Temperature
DMP5, DMP6, DMP7, DMP8, DMP80A, DMP80B	Dew point
GMP251, GMP252	Carbon dioxide
HPP271, HPP272	Vaporized hydrogen peroxide
MMP8	Moisture in oil

## Vaisala Indigo transmitters (host devices)

Indigo300, Indigo510, Indigo520
---------------------------------

## Other Vaisala devices

HMP60, HMP63, HMP110, HMP113, HMP115 probes HMM170 module	Humidity and temperature
HMP110T, HMP115T, TMP115 probes	Temperature
DMT143, DMT143L transmitters	Dew point
GMW90 and HMW90 series transmitters	Humidity, temperature, and carbon dioxide
MGP241 probe	Carbon dioxide
HMT370EX series transmitters	Humidity and temperature
PR53 series refractometers	Liquid concentration

# Technical data

## Operating environment

Operating temperature	-20 ... +50 °C (-4 ... +122 °F)
Storage temperature	-20 ... +60 °C (-4 ... +140 °F), recommended +20 °C (+68 °F)
Operating and storage humidity	20–85 %RH, when Ta ≤ +40 °C (+104 °F)
Charging temperature	0 ... +45 °C (+32 ... +113 °F) <sup>1)</sup>
IP rating	IP40
Use in wet location	No
Operating environment	Indoor use
Pollution degree	3
Maximum operating altitude	2000 m (approx. 6500 ft)

1) The battery will not charge at temperatures below 0 °C (+32 °F).

## Data logging and user interface specifications

Data logging capacity	Up to 5.5 million real-time data values
Logging interval	1 s - 12 h
Logging duration	1 min - memory full <sup>1)</sup>
Alarm	Audible alarm function
Supported languages	English, Chinese, Finnish, French, German, Italian, Japanese, Portuguese, Spanish, Swedish
Display	2.7" sunlight readable transfective TFT LCD color display with backlight and automatic brightness control

1) For example, data logging duration for one measurement parameter with a logging interval of one second is over eight weeks. Use an AC adapter to power Indigo80 during long-term logging.

## Battery operation time

Operation time (continuous use)	10 h at +20 °C (+68 °F) <sup>1)</sup>
Charging time	2 hours <sup>1)</sup>

1) Typical value. Actual performance depends on, for example, the number and type of devices connected to Indigo80 and the data logging interval.

## Mechanical specifications

Weight	385 g (14 oz)
Dimensions (H × W × D)	213 × 58 × 27 mm (8.4 × 2.3 × 1.1 in)
<b>Materials</b>	
Main body and rear piece	Aluminum EN AW-6082 T6
Back cover	Rubber (TPE) and polycarbonate (PC), reinforced with fiberglass Flammability rating UL94 V-1
Display	Strengthened glass with anti-fingerprint (AF) and anti-reflection (AR) coatings

## Compliance

EU directives and regulations	EMC Directive (2014/30/EU) RoHS Directive (2011/65/EU) as amended by 2015/863
Electromagnetic compatibility (EMC)	IEC/EN 61326-1, industrial environment CISPR 32 / EN 55032, Class B FCC part 15 B, Class B ICES-3 / NMB-3 (Class B)
Electrical safety	IEC/EN 61010-1
Compliance marks	CE, China RoHS, FCC, RCM, UKCA

## Inputs and outputs

Max. number of connected devices	2
Connector type	M12 5-pin female (2 pcs)
<b>Battery</b> <sup>1)</sup>	
Type	Rechargeable lithium-ion battery
Nominal voltage	7.2 V
Rated capacity	2900 mAh / 20.88 Wh
Charge limit voltage	8.4 V
<b>AC adapter</b> <sup>2)</sup>	
Type	45 W USB-C AC adapter <sup>3)</sup>
Connector type	USB-C
AC input	100-240 V AC, 1.2 A, 50-60 Hz
DC output	5.0 V/9.0 V/12.0 V/15.0 V DC, 3.0 A 20.0 V DC, 2.25 A 45 W
Insulation	Double or reinforced, indicated with the following symbol: 
PC interface	Vaisala Insight PC software with USB-C cable (Windows OS). <sup>4)</sup> Data can be logged and transferred also without Insight.

1) The battery is not user-replaceable. Contact Vaisala Service Center for any battery-related maintenance needs.

2) The AC adapter is an optional accessory. If using an AC adapter not provided by Vaisala, make sure it fulfills the specifications given in this table and the safety requirements listed in Indigo80 Safety Guide (M212872EN), available at docs.vaisala.com.

3) 45 W AC adapter recommended for optimal performance of Indigo80. An AC adapter with a lower power rating can also be used.

4) Insight software is available for download at [vaisala.com/insight](https://vaisala.com/insight).

## Spare parts and accessories

<b>Cables</b>	
Cable for transmitters (M12-M8), 1.5 m (4 ft 11 in)	262195SP
Cable for probes (M12-M12), 1.5 m (4 ft 11 in)	272075SP
Flat cable for probes (M12-M12), 1 m (3 ft 3 in)	CBL210493SP
Probe connection cable (M12-M12), 10 m (32 ft 10 in)	INDIGOCABLE10M
<b>Other</b>	
Magnetic hanger for indicator	ASM214318SP
Weatherproof carrying case for Indigo80 and HMP80 and DMP80 series probes	ASM214759
Weatherproof carrying case for Indigo80 and a series 8 probe <sup>1)</sup>	ASM215318
Light carrying case for HM40S or Indigo80 indicator and a compatible probe <sup>2)</sup>	230245SP

1) For example, MMP8, HMP8, or DMP8 with a max. 2-m (6 ft 7 in) probe connection cable.

2) For example, DMP80, HMP80N, or GMP252 probe with handle accessory and a max. 1.5-m (4 ft 11 in) probe connection cable.

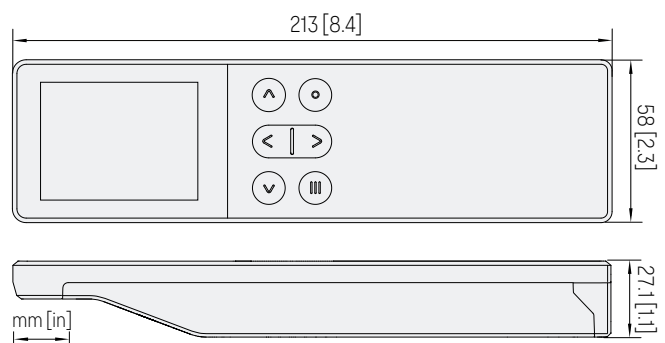

Indigo80 dimensions (front and side view)

## HMP80 Series Handheld Humidity and Temperature Probes

For spot-checking applications



### Features

- Portable design optimized for industrial spot-checking and field calibration
- RH accuracy up to  $\pm 0.8\%$  RH
- Temperature accuracy up to  $0.1\text{ }^{\circ}\text{C}$  ( $0.18\text{ }^{\circ}\text{F}$ )
- Wide temperature measurement range
- Condensation-tolerant
- Sensor purge improves long-term stability and chemical resistance
- Compatible with Indigo80 handheld indicator and Insight PC software
- Calibration certificate included

Vaisala HUMICAP® Handheld Humidity and Temperature Probes HMP80 Series have been designed for portable use, especially with the Indigo80 handheld indicator. The combination of HMP80 probe and Indigo80 is ideal for spot-checking and field calibration of installed Vaisala humidity instruments.

### Proven Vaisala HUMICAP performance

Vaisala is the original innovator of the thin-film capacitive humidity measurement technology, which has now become the industry standard in humidity measurement.

The HUMICAP technology results from Vaisala's 40-year experience in industrial humidity measurement, providing the best stability, fast response time, and low hysteresis in a wide range of applications.

HMP80 series probes are delivered with standard factory calibration certificates, with accredited calibration as an option. The probes can therefore be used as a working standard in field calibration.

### Robust design for handheld measurements

The HMP80 series probes are available in two lengths offering similar measurement performance. The longer model (HMP80L) is designed for measurements in more extreme temperatures.

The design of the probe handle has been optimized for manual operation in versatile measurement environments. The IP66-classified probe handle offers excellent protection against moisture and dust with the probe connection cable attached. Also the cable connection is protected against mechanical stress by the robust design of the handle.

### Flexible connectivity

HMP80 probes are optimized for portable spot-checking, field calibration, and data logging use with the Indigo80 handheld indicator. For easy-to-use access to device analytics and configuration, HMP80 probes can be connected to Vaisala Insight software for Windows®.

For more information, see [www.vaisala.com/indigo](http://www.vaisala.com/indigo) and [www.vaisala.com/insight](http://www.vaisala.com/insight).

# Technical data

## HMP80 series measurement performance

Relative humidity	
Measurement range	0-100 %RH
Accuracy at +23 °C (73.4 °F) <sup>1)</sup>	±0.8 %RH (0-90 %RH)
Factory calibration uncertainty <sup>2)</sup>	±0.5 %RH (0-40 %RH)
	±0.8 %RH (40-95 %RH)
T <sub>63</sub> response time	15 s
Sensor	HUMICAP® R2C
Temperature	
Measurement range	HMP80N: -20 ... +60 °C (-4 ... +140 °F) HMP80L: -50 ... +120 °C (-58 ... +248 °F), short-time measurement range -50 ... +180 °C (-58 ... +356 °F)
Accuracy at +23 °C (+73.4 °F) <sup>1) 3)</sup>	±0.1 °C (±0.18 °F)
Factory calibration uncertainty <sup>2)</sup>	±0.1 °C (±0.18 °F) at +23 °C (+73.4 °F)
Sensor	Pt100 RTD Class FO.1 IEC 60751

- 1) Defined against calibration reference. Including non-linearity, hysteresis, and repeatability.  
 2) Defined as ±2 standard deviation limits. Small variations possible; see calibration certificate.  
 3) Exposing temperature sensor to temperatures below -20 °C (-4 °F) may cause permanent additional deviation of ±0.1 °C (0.18 °F).

## HMP80 series operating environment

Operating temperature of probe handle	-10 ... +60 °C (-14 ... +140 °F)
Operating temperature of probe head	HMP80N: -20 ... +60 °C (-4 ... +140 °F)
	HMP80L: -50 ... +120 °C (-58 ... +248 °F)
Storage temperature	-20 ... +60 °C (-4 ... +140 °F)
Measurement environment	For air, nitrogen, hydrogen, argon, helium, oxygen, and vacuum <sup>1)</sup>
IP rating of probe handle:	
with probe connection cable connected to the probe	IP66
without cable	IP55

- 1) Consult Vaisala if other chemicals are present. Consider safety regulations with flammable gases.

## HMP80 series inputs and outputs

Operating voltage	15-30 V DC
Current consumption	10 mA typical, 500 mA max.
Digital output	RS-485, non-isolated

## HMP80 series compliance

EU directives and regulations	EMC Directive (2014/30/EU) RoHS Directive (2011/65/EU) as amended by 2015/863
Electromagnetic compatibility (EMC)	EN 61326-1, industrial environment
Rough handling (excluding sensor inside probe head)	IEC 60068-2-31
Compliance marks	CE, China RoHS, RCM, UKCA

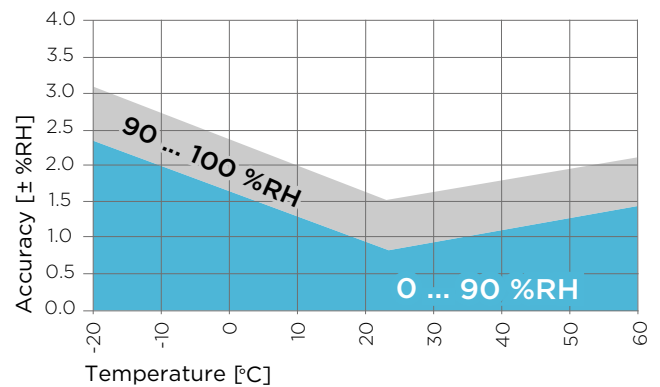

HMP80N humidity measurement accuracy as a function of temperature

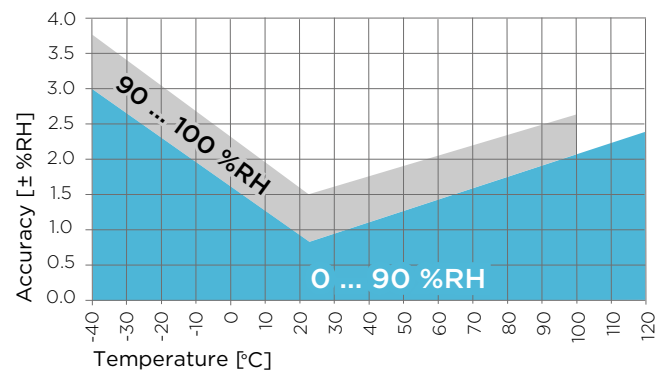

HMP80L humidity measurement accuracy as a function of temperature

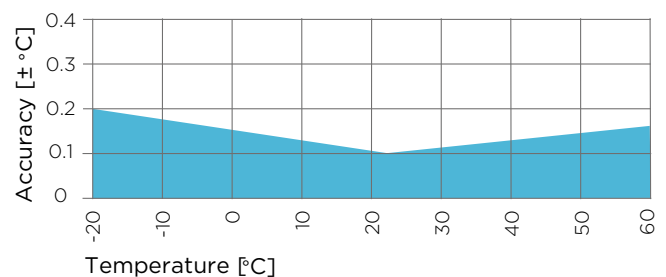

HMP80N temperature measurement accuracy over full range

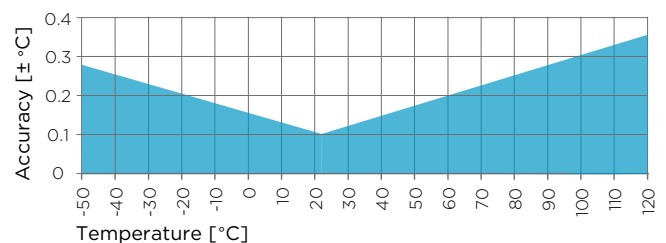

HMP80L temperature measurement accuracy over full range

## HMP80 series output parameters

Absolute humidity (g/m <sup>3</sup> )	Relative humidity (%RH)
Absolute humidity at NTP (g/m <sup>3</sup> )	Relative humidity (dew/frost) (%RH)
Dew point temperature (°C)	Temperature (°C)
Dew/frost point temperature (°C)	Water concentration (ppm <sub>w</sub> )
Dew/frost point temperature at 1 atm (°C)	Water concentration (wet basis) (vol-%)
Dew point temperature at 1 atm (°C)	Water mass fraction (ppm <sub>w</sub> )
Dew point temperature difference (°C)	Water vapor pressure (hPa)
Enthalpy (kJ/kg)	Water vapor saturation pressure (hPa)
Mixing ratio (g/kg)	Wet-bulb temperature (°C)

## HMP80 series mechanical specifications

Connector type	M12 5-pin A-coded male
Weight	HMP80N: 200 g (7 oz) HMP80L: 300 g (10 oz)
<b>Materials</b>	
Probe handle	Polyamide (PA) and thermoplastic elastomer (TPE)
Probe shaft	Stainless steel (AISI 316L)
Filters	HMP80N: Stainless steel (AISI 316L) <sup>1)</sup> HMP80L: Porous stainless steel (AISI 316L) <sup>2)</sup>

1) With holes and without an additional filter membrane. Vaisala item code of filter: DRW255306SP.  
2) Vaisala item code: HM47280SP

## HMP80 series spare parts and accessories

Probe connection cable (M12-M12), 1.5 m (4.11 ft)	272075SP
Flat cable for probes (M12-M12), 1.0 m (3.4 ft)	CBL210493SP
Indigo USB adapter	USB2
Sintered stainless steel filter (HMP80N, HMP80L)	HM47280SP
Plastic PPS grid filter (HMP80N, HMP80L)	DRW010276SP
PPS grid with SS netting (HMP80N, HMP80L)	DRW010281SP
Slotted MIM filter (HMP80N)	DRW255306SP
Slotted MIM filter with membrane (HMP80N)	ASM214606SP

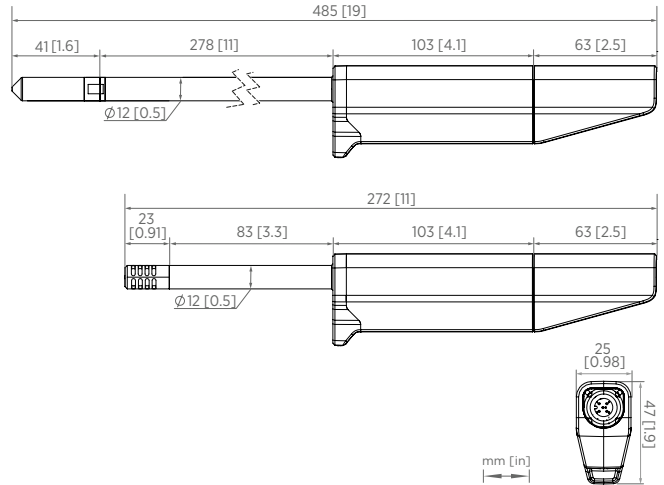

Dimensions of HMP80L (top) and HMP80N (bottom), side and bottom view

## DMP80 Series Handheld Dew Point and Temperature Probes

For spot-checking applications



### Features

- Portable design optimized for industrial spot-checking and field calibration
- Dew point measurement accuracy up to  $\pm 2$  °C ( $\pm 3.6$  °F)  $T_{d/f}$
- Wide dew point measurement range
- Sensor purge improves long-term stability and chemical resistance
- Condensation-tolerant
- Compatible with Indigo80 handheld indicator and Insight PC software
- Calibration certificate included

Vaisala DRYCAP® Handheld Dew Point and Temperature Probes DMP80 Series have been designed for portable use, especially with the Indigo80 handheld indicator. The combination of DMP80 probe and Indigo80 is ideal for spot-checking and field calibration of installed Vaisala humidity instruments.

### Reliable measurements with the Vaisala DRYCAP sensor

Vaisala DRYCAP sensor is robust against particulate contamination, water condensation, oil vapor, and most chemicals. The sensor tolerates condensation and recovers perfectly if exposed to liquid water. The sensor's performance is excellent also in dynamic and low dew point applications, thanks to its fast reaction time and stability.

The probes can be inserted directly into pressurized processes, and respond rapidly from ambient to process conditions. The DMP80 probes are suitable for direct process dew point measurement in a wide temperature and pressure range.

DMP80 series probes are delivered with standard factory calibration certificates, with accredited calibration as an option. The probes can therefore be used as a working standard in field calibration.

### Sensor purge minimizes effects of contaminants

In environments with high concentrations of chemicals and cleaning agents, the sensor purge option helps to maintain measurement accuracy between calibration intervals.

Sensor purge involves heating the sensor briefly to remove chemicals that could lower measurement performance and cause drifting.

### Robust design for handheld measurements

The design of the probe handle has been optimized for manual operation in versatile measurement environments. The IP66-classified probe handle offers excellent protection against moisture and dust with the probe connection

cable attached. Also the cable connection is protected against mechanical stress by the robust design of the handle.

### Flexible connectivity

DMP80 probes are optimized for portable spot-checking, field calibration, and data logging use with the Indigo80 handheld indicator. For easy-to-use access to device analytics and configuration, DMP80 probes can be connected to Vaisala Insight software for Windows®.

For more information, see [www.vaisala.com/indigo](http://www.vaisala.com/indigo) and [www.vaisala.com/insight](http://www.vaisala.com/insight).

# Technical data

## DMP80A measurement performance

Dew point	
Sensor	DRYCAP® 180S
Measurement range	-40 ... +60 °C (-40 ... +140 °F) T <sub>d/f</sub>
Accuracy	Up to ±2 °C (±3.6 °F) T <sub>d/f</sub>
Response time 63 % [90 %]:	
From dry to wet	5 s [10 s]
From wet to dry	45 s [5 min]
Temperature	
Measurement range	0 ... +60 °C (+32 ... +140 °F)
Accuracy	±0.2 °C (±0.36 °F) at room temperature
Temperature sensor	Pt100 RTD Class F0.1 IEC 60751
Mixing ratio	
Measurement range (typical)	0-150 g/kg (0-1050 gr/lbs)
Accuracy (typical)	±12 % of reading
Absolute humidity	
Measurement range	0-130 g/m <sup>3</sup>
Accuracy (typical)	±10 % of reading

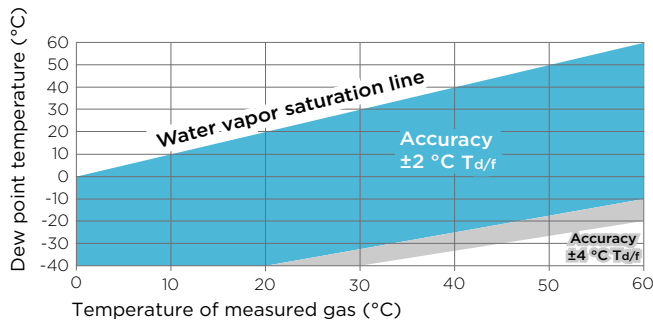

Dew point accuracy vs. measurement conditions (DMP80A)

## DMP80 series operating environment

Operating temperature range	-10 ... +60 °C (+14 ... +140 °F)
Storage temperature	-20 ... +60 °C (-4 ... +140 °F)
Operating pressure of probe head	0-20 bar (0-290 psi), absolute
Measurement environment	For air, nitrogen, hydrogen, argon, helium, and oxygen <sup>1)</sup>
IP rating of probe handle:	
With probe connection cable connected to the probe	IP66
Without cable	IP55

<sup>1)</sup> Consult Vaisala if other chemicals are present. Consider safety regulations with flammable gases.

## DMP80 series inputs and outputs

Operating voltage	15-30 V DC
Current consumption	10 mA typical, 500 mA max.
Digital output	RS-485, non-isolated

## DMP80B measurement performance

Dew point	
Sensor	DRYCAP® 180M
Measurement range	-70 ... +60 °C (-94 ... +140 °F) T <sub>d/f</sub>
Accuracy	Up to ±2 °C (±3.6 °F) T <sub>d/f</sub>
Response time 63 % [90 %]:	
From dry to wet	5 s [15 s]
From wet to dry	45 s [8 min]
Temperature	
Measurement range	0 ... +60 °C (+32 ... +140 °F)
Accuracy	±0.2 °C (±0.36 °F) at room temperature
Temperature sensor	Pt100 RTD Class F0.1 IEC 60751
Relative humidity	
Measurement range	0-70 %RH
Accuracy (RH <10 %RH, at +20 °C)	±0.004 %RH + 20 % of reading
Concentration by volume (ppm)	
Measurement range (typical)	10-2500 ppm
Accuracy (at +20 °C, 1 bar)	1 ppm + 20 % of reading

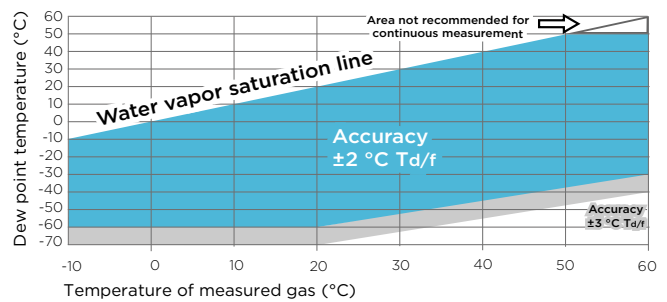

Dew point accuracy vs. measurement conditions (DMP80B)

## DMP80 series mechanical specifications

Connector type	M12 5-pin A-coded male
Weight	250 g (9 oz)
Mechanical connection options	G1/2" ISO 228/1 NPT1/2"
Materials	
Probe handle	Polyamide (PA) and thermoplastic elastomer (TPE)
Probe shaft	Stainless steel (AISI 316L)
Filter	Porous stainless steel (AISI 316L) <sup>1)</sup>

<sup>1)</sup> Vaisala item code: HM47280SP

## DMP80 series output parameters

Absolute humidity (g/m <sup>3</sup> )	Relative humidity (%RH)
Absolute humidity at NTP (g/m <sup>3</sup> )	Relative humidity (dew/frost) (%RH)
Dew point temperature (°C)	Temperature (°C)
Dew/frost point temperature (°C)	Water concentration (ppm <sub>v</sub> )
Dew/frost point temperature at 1 atm (°C)	Water concentration (wet basis) (vol-%)
Dew point temperature at 1 atm (°C)	Water mass fraction (ppm <sub>w</sub> )
Dew point temperature difference (°C)	Water vapor pressure (hPa)
Enthalpy (kJ/kg)	Water vapor saturation pressure (hPa)
Mixing ratio (g/kg)	

## DMP80 series compliance

EU directives and regulations	EMC Directive (2014/30/EU) RoHS Directive (2011/65/EU) as amended by 2015/863
Electromagnetic compatibility (EMC)	EN 61326-1, industrial environment
Rough handling (excluding sensor inside probe head)	IEC 60068-2-31
Compliance marks	CE, China RoHS, RCM, UKCA

## DMP80 series spare parts and accessories

<b>Cables</b>	
Probe connection cable (M12-M12), 1.5 m (4.11 ft)	272075SP
Flat cable for probes (M12-M12), 1.0 m (3.4 ft)	CBL210493SP
<b>Accessories for ISO G1/2" thread option</b>	
Sampling cell with quick connector and leak screw	DSC74
Sampling cell with female connectors, inlet G3/8", outlet G1/4" ISO	DMT242SC
Sampling cell with Swagelok connectors for 1/4" tubing	DMT242SC2
Two-pressure sampling cell	DSC74B
Two-pressure sampling cell with coil	DSC74C
<b>Other items</b>	
Indigo USB adapter	USB2
Sintered stainless steel filter	HM47280SP

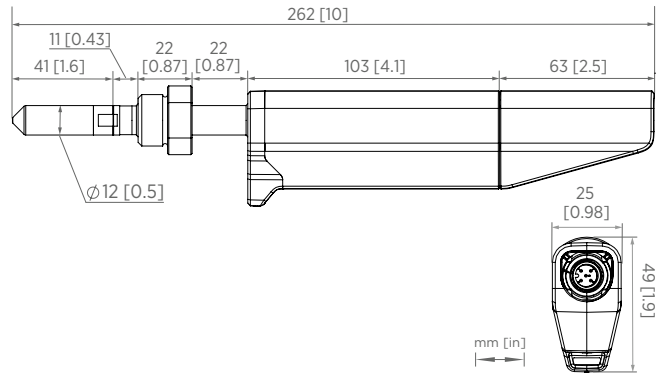

Dimensions of DMP80 series probes with G1/2" thread, side and bottom view

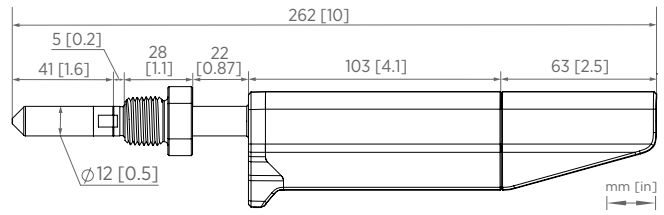

Dimensions of DMP80 series probes with NPT1/2" thread



### Features

- Humidity measurement range 0 ... 100 %RH
- Temperature measurement ranges -40 ... +100 °C (-40 ... +212 °F), depending on probe model. The HM46 model can measure up to +180 °C (+356 °F) for a short period of time.
- Incorporates proven Vaisala HUMICAP® sensor technology
- Calibration reminder function
- Probes can be user calibrated using an on-site reference
- Graphical display indicates when measurement has stabilized
- Hold-button to freeze the screen and save the reading
- Multilingual user interface available in 10 languages (EN, DE, FR, JA, ZH, PT, ES, RU, FI, SV)

The easy-to-use HM40 is a compact and portable humidity meter that provides reliable measurements in a wide range of applications. It is the ideal spot-checking tool for everything from structural moisture measurement and air conditioning systems to humidity measurement in industrial production processes and life science applications. There are four different models available: HM41, HM42, HM45, and HM46.

### Benefits

- Compact, portable, and easy to use
- Versatile meter with wide measurement range and multiple calculated parameters
- Ideal for spot-checking in a wide variety of applications

### Simple and Easy to Use

HM40 has a large, user-friendly graphical display and easy-to-use push buttons. The user interface is simple and intuitive, and available in 10 languages. Also, many settings can be modified to meet users' individual needs. In addition to relative humidity and temperature, HM40 provides five calculated humidity

parameters, all of which are available in metric and non-metric units. HM40 is powered by 2 AA batteries. An external USB-charger and rechargeable AA sized NiMH batteries are available as an option. Each model also comes with a handy belt clip and case.

### Easy Recalibration

Calibrating HM40 is easy. The meter or the probe can be sent to a Vaisala Service Center for recalibration. Alternatively, calibration can be completed on site by users with a humidity reference such as another hand-held meter or Vaisala Humidity Calibrator HMK15. The indicator includes a calibration reminder function that can be activated by the user.

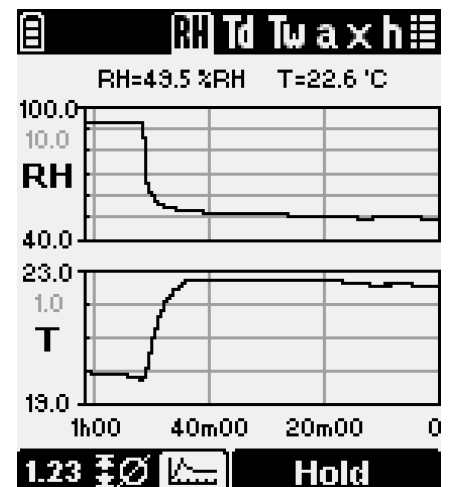

The Graph Clearly Indicates When Readings Have Stabilized.

# HM40 Handheld Humidity and Temperature Meter Series



## HM41 Technical Data

Humidity Measurement Accuracy (Including Non-linearity, Hysteresis, and Repeatability):

At 0 ... +40 °C	±1.5 %RH (0 ... 90 %RH)
	±2.5 %RH (90 ... 100 %RH)
At -10 ... 0 °C and +40 ... +60 °C	±3.0 %RH (0 ... 90 %RH)
	±4.0 %RH (90 ... 100 %RH)

Humidity sensor	HUMICAP® 180R
Temperature measurement range	-10 ... +60 °C (+14 ... +140 °F)
Temperature sensor	Pt1000 RTD Class F0.1 IEC 60751
Measurement probe	Interchangeable HMP113 probe
Probe material	PC/ABS plastic blend (white)
IP rating	IP54
Weight (with alkaline batteries)	230 g (8.1 oz)
Filter material	PC (glass-reinforced)

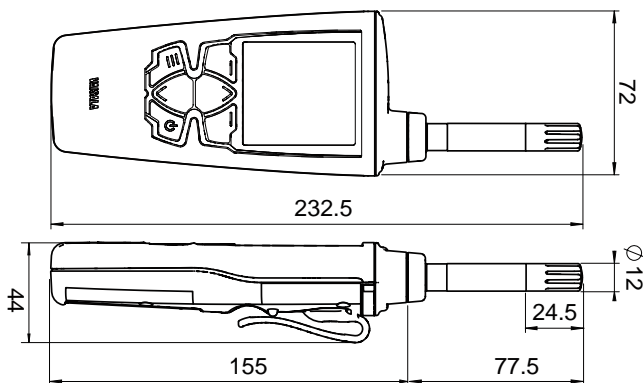

HM41 dimensions in mm

## HM42 Technical Data

Humidity Measurement Accuracy (Including Non-linearity, Hysteresis, and Repeatability):

At 0 ... +40 °C	±1.5 %RH (0 ... 90 %RH)
	±2.5 %RH (90 ... 100 %RH)
At -40 ... 0 °C and +40 ... +80 °C	±3.0 %RH (0 ... 90 %RH)
	±4.0 %RH (90 ... 100 %RH)
At +80 ... +100 °C	±4.0 %RH <sup>1)</sup>

Humidity sensor	HUMICAP® 100R-Mini
Temperature measurement range	-40 ... +100 °C (-40 ... +212 °F)
Temperature sensor	Pt1000 RTD Class F0.3 IEC60751
Measurement probe	HM42PROBE
Probe head material	Stainless steel
IP rating	IP40 (probe), IP54 (indicator)
Weight (with alkaline batteries)	370 g (13.1 oz)
Filter material	Stainless steel and PTFE membrane
Probe cable length	1500 mm (59 in)

<sup>1)</sup> Not recommended for  $T_d > 85 °C$

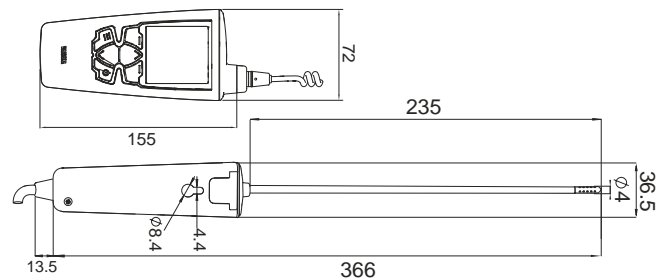

HM42 dimensions in mm



### HM45 Technical Data

Humidity Measurement Accuracy (Including Non-linearity, Hysteresis, and Repeatability):

At 0 ... +40 °C	±1.5 %RH (0 ... 90 %RH)
	±2.5 %RH (90 ... 100 %RH)
At -40 ... 0 °C and +40 ... +60 °C	±3.0 %RH (0 ... 90 %RH)
	±4.0 %RH (90 ... 100 %RH)

Humidity sensor	HUMICAP® 180R
Temperature measurement range	-40 ... +60 °C (-40 ... +140 °F)
Temperature sensor	Pt1000 RTD Class F0.1 IEC 60751
Measurement probe	Interchangeable HMP113 with HM40HANDLE
Probe material	PC/ABS plastic blend (white)
IP rating	IP54
Weight (with alkaline batteries)	330 g (11.6 oz)
Filter material	PC (glass-reinforced)
Probe cable length	1200 mm (47 in)

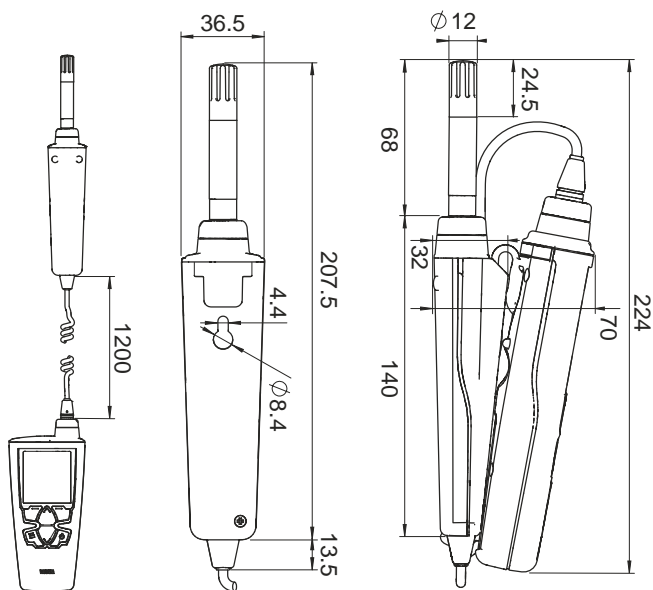

HM45 dimensions in mm

### HM46 Technical Data

Humidity Measurement Accuracy (Including Non-linearity, Hysteresis, and Repeatability):

At 0 ... +40 °C	±1.5 %RH (0 ... 90 %RH)
	±2.5 %RH (90 ... 100 %RH)
At -40 ... 0 °C and +40 ... +80 °C	±3.0 %RH (0 ... 90 %RH)
	±4.0 %RH (90 ... 100 %RH)
At +80 ... +100 °C	±4.0 %RH <sup>1)</sup>

Humidity sensor	HUMICAP® 180R
Temperature measurement range	-40 ... +100 °C (-40 ... +212 °F), short-term up to +180 °C (+356 °F)
Temperature sensor	Pt1000 RTD Class F0.1 IEC 60751
Measurement probe	HM46PROBE
Probe head material	Stainless steel, brass filter
IP rating	IP40 (probe), IP54 (indicator)
Weight (with alkaline batteries)	490 g (17.3 oz)
Filter material	Sintered brass
Probe cable length	1500 mm (59 in)

<sup>1)</sup> Not recommended for  $T_g > 85$  °C

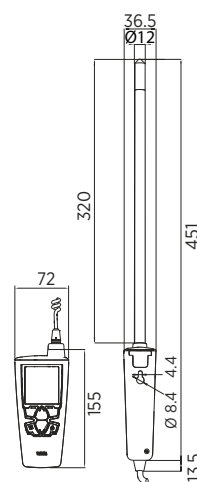

HM46 dimensions in mm

# HM40 Series Technical Data

## Measurement Performance

Calculated parameters	Dew point, wet bulb temperature, absolute humidity, mixing ratio, enthalpy
<b>Relative Humidity</b>	
Measurement range	0 ... 100 %RH
Accuracy (including non-linearity, hysteresis, and repeatability) for different models at 0 ... +40 °C (+32 ... +104 °F)	±1.5 %RH (0 ... 90 %RH) ±2.5 %RH (90 ... 100 %RH)
Factory calibration uncertainty at +20 °C (+68 °F):	
HM42 and HM46	±1.5 %RH
HM41 and HM45	±1.1 %RH (0 ... 90 %RH) ±1.8 %RH (90 ... 100 %RH)
Stability	±2 %RH over 2 years
Humidity Measurement Response Time:	
(90 %) with plastic grid filter (HM41 and HM45)	17 s
(90 %) with membrane filter and steel grid (HM42)	26 s
(90 %) with brass sintered filter (HM46)	40 s
<b>Temperature</b>	
Accuracy over temperature range:	
At 0 ... +40 °C (+32 ... +104 °F)	±0.2 °C (0.36 °F)
At -40 ... 0 °C and +40 ... +100 °C (-40 ... +32 °F and +104 ... +212 °F)	±0.4 °C (0.72 °F)

## Operating Environment

<b>Operating temperature</b>	
Indicator	-10 ... +60 °C (+14 ... +140 °F)
Probe handle	-40 ... +60 °C (-40 ... +140 °F)
Probe head	Range -40 ... +180 °C (-40 ... +356 °F) See probe specifications
Storage temperature	-30 ... +70 °C (-22 ... +158 °F)
EMC compliance	EN61326-1, Portable Equipment

## Mechanical Specifications

<b>Materials</b>	
Indicator body	PC/ABS blend, acrylic display lens
Probe holder	PC/ABS blend (gray)
Probe handle	PC/ABS blend (white), PC/ABS blend (gray, HM45) or PBT (gray, HM42/46)
HMP113 probe or probe measurement head	PC/ABS blend (white, HM41/45) or stainless steel (HM42/46)
IP rating, HM40	IP54

## Indicator

Display	LCD (140 x 160 pixels)
Power-up time	< 3 s
Batteries	2 × AA, 1.5 V
Operation time (typical)	100 hours (without backlight)
Menu languages	English, Chinese (simplified), Finnish, French, German, Japanese, Portuguese, Russian, Spanish, Swedish

## Spare Parts and Accessories

<b>Indicator</b>	
Spare HM40 indicator	HM40INDI
Belt clip (3 pcs)	227710SP
Battery cover (3 pcs)	225688SP
NiMH rechargeable batteries (4 pcs)	229247SP
External battery recharger with USB connection and 4 batteries	229249SP
Case for short HM40 probes	235849SP
Case for long HM40 probes	DRW242351SP
<b>Standard Probe (HM41)</b>	
HMP113 probe for HM40	HMP113 (configuration: V00B2C1A0)
Plastic locking bushing (3 pcs) for attaching HMP113 probe to HM40 indicator	DRW238590SP
Plastic grid filter for HMP113 probe	DRW236214SP
Plastic grid with membrane filter for HMP113 probe	230727SP
<b>HM42 Probe (HM42)</b>	
Thin 4 mm diameter probe for HM40	HM42PROBE
Steel grid filter for HM42PROBE	19867HM
Membrane tube set (5 pcs) for HM42PROBE	19858HM
Rubber sleeve set (10 pcs) for HM42PROBE	19809HM
Calibration adapter for HM42PROBE	HM37067
<b>Remote Probe (HM45)</b>	
HMP113 probe for HM40	HMP113 (configuration: V00B2C1A0)
Plastic locking bushing (3 pcs) for attaching HMP113 probe to HM40 indicator	DRW238590SP
HM40 handle and cable	HM40HANDLE
Plastic grid filter for HMP113 probe	DRW236214SP
Plastic grid with membrane filter for HMP113 probe	230727SP
<b>HM46 Probe (HM46)</b>	
Stainless steel 12 mm diameter probe for HM40	HM46PROBE
Sintered filter for HM46PROBE	0195
Optional membrane filter for HM46PROBE (up to +80 °C)	10159HM
Plastic grid filter for HM46PROBE (up to +80 °C)	6221
Disposable sleeve, 50 pcs set	1558
Probe holder	HM36915

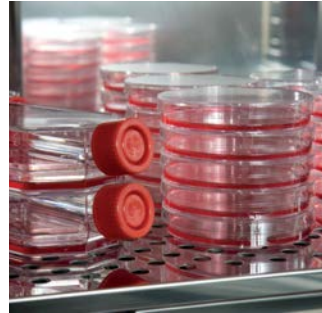

### CARBOCAP's unique benefits

- Superior stability enabled by autocalibration
- Insensitive to harsh conditions
- Minimal maintenance and calibration requirements

The Vaisala CARBOCAP sensor features an electrically tunable FPI filter. In addition to measuring gas absorption, the micromechanical FPI filter enables a reference measurement at a wavelength where no absorption occurs. When taking the reference measurement, the FPI filter is electrically adjusted to switch the bypass band from the absorption wavelength to a non-absorption wavelength. The reference measurement compensates for any potential changes in the light source intensity, as well as for contamination and dirt accumulation in the optical path. This feature means that CARBOCAP sensor operation is highly stable over time.

Instruments measuring at several absorption and reference wavelengths with a single light source are known as single-beam multi-wavelength instruments. The technology is widely applied in costly analyzers. The unique feature of the CARBOCAP® sensor is its micromachined FPI filter, which performs a multiwavelength measurement using a single detector. The compact size of the sensor means that this advanced technology can be incorporated into small probes, modules, and transmitters.

First launched in 1997, the Vaisala CARBOCAP sensor features a groundbreaking innovation – the micromachined, electrically tunable Fabry-Pérot Interferometer (FPI) filter for built-in reference measurement. This reliable and stable sensor has been delivering accurate measurements since the late 1990s across a wide range of industries and applications, from building automation and safety to life sciences and ecological research.

### How it works

Gases have a characteristic absorbance band in the infrared (IR) region, each at a unique wavelength. When IR radiation is passed through a gas containing another gas we are measuring, part of the radiation is absorbed. Therefore, the amount of radiation passing through the gas depends on the amount of the measured gas present, and this can be detected with an IR detector.

Vaisala uses a single-beam and dual-wavelength NDIR (Non-dispersive infrared) technology for measuring CO<sub>2</sub>. The patented CARBOCAP technology is used in all our CO<sub>2</sub> sensors. This technology incorporates a unique tunable band pass filter that was developed by Vaisala and is manufactured in our own state-of-the-art cleanroom. Learn more on our [carbon dioxide page](#).

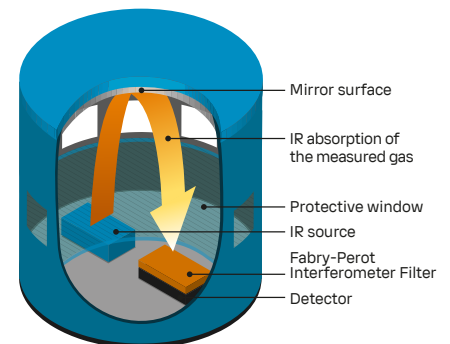

Structure of the CARBOCAP sensor. Both reference and gas absorption are measured in the same optical path.

### Typical applications for carbon dioxide measurement

Vaisala CARBOCAP sensor technology is well suited to a wide range of applications, but since the final customer value for each industrial application is unique, it depends on the product line how the CARBOCAP sensor technology is implemented. In carbon dioxide measurement products, the technology is utilized for both ppm (parts per million) and percentage level measurements. Since CO<sub>2</sub> replaces oxygen, it can be harmful to people in very high concentrations. CO<sub>2</sub> is present at percentage levels only within closed processes such as fermentation and controlled atmosphere storage

environments. Percentage-level measurements are also typical in life-science applications such as CO<sub>2</sub> incubators.

Normal atmospheric air includes CO<sub>2</sub> at ppm levels. Typical CARBOCAP applications include ventilation control in buildings occupied by people, animal shelters, and greenhouses. In areas where large volumes of CO<sub>2</sub> are handled,

reliable CO<sub>2</sub> measurement with alarm control is an important safety precaution. The CARBOCAP sensor is also a popular choice in ecological measurement applications such as biogas process lines, where excellent long-term stability and tolerance to harsh conditions are important requirements. For biogas applications, the technology is applied for multigas measurements, as it also helps improve the methane quality in the process.

### Product examples

Vaisala's instruments including the CARBOCAP sensor technology range from handheld meters, measurement modules, and industrial transmitters for CO<sub>2</sub> measurements to multigas measurement solutions.

## MGP241 Multigas Probe

For carbon dioxide and humidity measurement



### Features

- Continuous process monitoring for carbon capture, utilization and storage (CCUS) applications
- Direct installation into process: no moisture removal or other sample treatment needed
- Standalone probe with digital Modbus® RTU over RS-485 and 3 analog outputs (4–20 mA)
- Analog input (4–20 mA) for external temperature or pressure compensation for more accurate measurement
- Available measurement parameters: carbon dioxide (CO<sub>2</sub>) and humidity (H<sub>2</sub>O vapor)
- Compatible with Vaisala Insight PC software and Vaisala Indigo80, Indigo300, and Indigo520

Vaisala CARBOCAP® MGP241 Multigas Probe for Carbon Dioxide and Humidity Measurement is designed for continuous measurement of carbon dioxide (CO<sub>2</sub>) and humidity (H<sub>2</sub>O vapor) measurements in industrial processes, especially in carbon capture, utilization and storage (CCUS) applications. It is designed to be installed directly in the process gas pipeline, removing the need for sample treatment.

### 2-in-1 measurement probe

The MGP241 probe measures carbon dioxide (CO<sub>2</sub>) and humidity (H<sub>2</sub>O vapor) in demanding conditions. MGP241 measures carbon dioxide and humidity in vol-% or ppm by volume units, or alternatively dew point temperature (T<sub>d</sub>) and frost point temperature (T<sub>f</sub>). The patented CARBOCAP infrared technology enables simultaneous detection of multiple gases unlike the traditional non-dispersive infrared (NDIR) measurement technique. This allows compensation for sensor drift, sensor aging, and for any cross-interference effects between measured gases. Calibration gases are not needed for routine operation; a functional check and drift check every 12 months is recommended.

### Continuous process monitoring

MGP241 measures gases directly in the process without a need for drying or other sample treatment. This simplifies the installation and minimizes the footprint of the measurement solution compared to traditional gas analyzers. The rapid measurement cycle takes only seconds, providing direct real time measurements for process control and monitoring. The CO<sub>2</sub> measurement can be shown either as wet basis or dry basis values. Thanks to the built in temperature and pressure compensation algorithms, and the CARBOCAP infrared technology, the measurement is stable and reliable across a wide range of process and environmental conditions.

### Flexible connectivity

The MGP241 probe has 3 4–20 mA analog outputs for CO<sub>2</sub> and H<sub>2</sub>O vapor concentrations and for retransmission of analog input, as well as a 4–20 mA analog input for external pressure or temperature signal used for compensation. The probe also offers Modbus RTU protocol for digital connectivity. For easy-to-use access to configuration, diagnostics, and calibration and adjustment functionalities, the MGP241 probe can be connected to Vaisala Insight PC software with a USB cable accessory, and it can also be connected to Indigo devices: Indigo80, Indigo300, and Indigo520.

# Technical data

## Measurement performance

Property	Carbon dioxide CO <sub>2</sub>	Water vapor H <sub>2</sub> O
Sensor	CARBOCAP®	CARBOCAP®
Measurement unit	Volume-%, ppm <sub>v</sub>	Volume-%, ppm <sub>v</sub> , dew point °C, dew point °F
Measurement range	0–100 vol-%	0–25 vol-%, –10 ... +60 °C (+14 ... +140 °F)
Accuracy at +25 °C (+77 °F) and 1013 mbar <sup>1)</sup> 2)	0–90 vol-%: <b>±2 vol-%</b> 90–100 vol-%: <b>±1 vol-%</b>	0–25 vol-%: <b>±0.5 vol-%</b>
Repeatability <sup>2)</sup>	±0.4 vol-% at 95 vol-%	±0.1 vol-% at 2.5 vol-%
Temperature dependence (typical)	Compensated, 0–100 vol-%: <b>±0.1 % of reading / °C</b> Uncompensated, 0–100 vol-%: <b>±0.6 % of reading / °C</b>	Compensated, 0–25 vol-%: <b>±0.1 % of reading / °C</b> Uncompensated, 0–25 vol-%: <b>±0.4 % of reading / °C</b>
Pressure dependence (typical)	Compensated, 0–100 vol-%: <b>±0.015 % of reading / mbar</b> Uncompensated, 0–100 vol-%: <b>±0.25 % of reading / mbar</b>	Compensated, 0–25 vol-%: <b>±0.01 % of reading / mbar</b> Uncompensated, 0–25 vol-%: <b>±0.20 % of reading / mbar</b>
Long-term stability	±2 vol-% / year	±2 vol-% / year
Startup time <sup>3)</sup>		3 min
Warm-up time <sup>4)</sup>		30 s <sup>5)</sup>
Response time (T <sub>90</sub> )		90 s <sup>6)</sup>
Response time with flow-through adapter		90 s at ≥ 0.5 l/min <sup>6)</sup> (recommended: 0.5–1 l/min)

1) Excluding cross-interferences to other gases.

2) Accuracy and repeatability specification at +25 °C (+77 °F) and 1013 mbar including non-linearity, calibration uncertainty, and repeatability; temperature and pressure compensated.

3) Time to first reading.

4) Time to specified accuracy.

5) At +20 °C (+68 °F) ambient temperature.

6) With standard PTFE filter.

## Powering

Operating voltage	19–30 V DC
Power consumption	Typical: 3 W Maximum: 6 W
Current consumption	100–300 mA

## Inputs and outputs

Analog inputs	
Number of analog inputs	1
Input type	4–20 mA, isolated, for external pressure or temperature sensor <sup>1)</sup>
Analog outputs	
Number of analog outputs	3
Output type	4–20 mA, scalable, isolated
Accuracy	±0.2 % F.S. at 25 °C
Temperature dependence	±0.005% / °C full scale
External loads	R <sub>L</sub> : 0 Ω R <sub>L</sub> : 500 Ω
Digital communication	
Serial communication	RS-485 (Modbus RTU)

1) The optional analog input is galvanically isolated and provides power for the connected external pressure sensor.

## Operating environment

Operating environment	Outdoor use
IP rating	IP65
Operating temperature	–40 ... +60 °C (–40 ... +140 °F)
Operating humidity	0–100 %RH
Operating pressure	–500 ... +500 mbar (gauge)
Storage temperature	–40 ... +60 °C (–40 ... +140 °F)
Storage humidity	0–90 %RH
Process pressure	–500 ... +500 mbar (gauge)
Process temperature	+0 ... +60 °C (+32 ... +140 °F)
Process flow	0–20 m/s

## Mechanical specification

Weight	1.4 kg (3.09 lb)
Connectors	M12 5-pin male for digital output M12 8-pin male for analog output M12 4-pin female for analog input
Materials	
Probe body	AISI316L stainless steel, PPS
Filter cap	Sintered PTFE

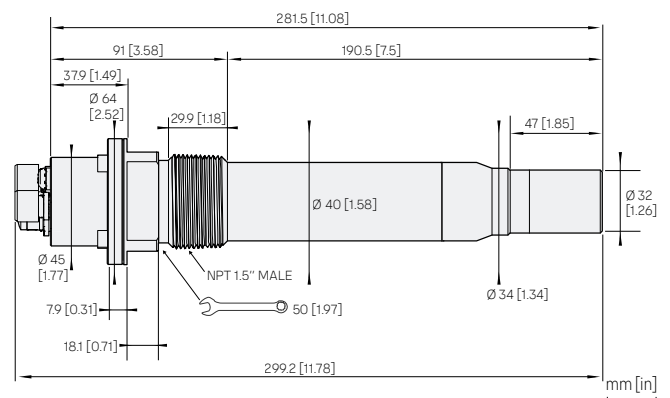

MGP241 dimensions

## Compatible devices

Device or series	Models
Indigo80 Handheld Indicator	Indigo80
Indigo300 Transmitter	Indigo300
Indigo500 Series Transmitters	Indigo520

## Accessories and spare parts

Sintered PTFE filter (includes O-ring)	DRW249919SP
Flow-through adapter	258877
NPT 1.5 in thread test plug	257525SP
USB Service Cable M12-5F, RS-485	242659

## Compliance

EU directives and regulations	EMC Directive (2014/30/EU) REACH Regulation (EC 1907/2006) RoHS Directive (2011/65/EU) as amended by 2015/863
Electromagnetic compatibility (EMC)	EN 61326-1, industrial environment
Compliance marks	CE, China RoHS, FCC, ICES, RCM

## GMP343 Carbon Dioxide Probe For demanding measurements



### Features

- Vaisala CARBOCAP® sensor, a silicon-based non-dispersive infrared (NDIR) sensor
- Single-beam, dual wavelength CO<sub>2</sub> measurement with no moving parts
- Compensation options for temperature, pressure, humidity, and oxygen
- Designed for outdoor use

Vaisala CARBOCAP® Carbon Dioxide Probe GMP343 is an accurate and rugged probe-type instrument for ecological measurements. Typical applications include CO<sub>2</sub> soil respiration, ambient CO<sub>2</sub> monitoring, plant growth chambers, and OEM applications.

### Benefits

- Low power consumption and heat emission
- Compact and lightweight
- Excellent accuracy and stability

GMP343 can output both numerically filtered and raw measurement data, and it can also compensate the measurement with an internal temperature measurement and user-set relative humidity, pressure, and oxygen values.

In combination with an MI70 indicator, GMP343 provides a tool for accurate in-situ measurement. MI70 can be used as a display, communication, and data logging device.

Each GMP343 is calibrated using  $\pm 0.5\%$  accurate gases at 0 ppm, 200 ppm, 370 ppm, 600 ppm, 1000 ppm, 4000 ppm, and 2%. Calibration is also done at temperature points of  $-30\text{ }^{\circ}\text{C}$  ( $-22\text{ }^{\circ}\text{F}$ ),  $0\text{ }^{\circ}\text{C}$  ( $32\text{ }^{\circ}\text{F}$ ),  $25\text{ }^{\circ}\text{C}$  ( $77\text{ }^{\circ}\text{F}$ ), and  $50\text{ }^{\circ}\text{C}$  ( $122\text{ }^{\circ}\text{F}$ ).

If needed, the customer can recalibrate the instrument using the multipoint calibration (MPC) feature allowing up to 8 user-defined calibration points.

# Technical data

## Measurement performance

Measurement range options	0 ... 1000 ppm, 0 ... 2000 ppm, 0 ... 3000 ppm, 0 ... 4000 ppm, 0 ... 5000 ppm, 0 ... 2 %
---------------------------	---

### Accuracy (excluding noise) at 25 °C (77 °F) and 1013 hPa after factory calibration with 0.5 % accurate gases with different range options

0 ... 1000 ppm	±(3 ppm + 1 % of reading)
0 ... 2000 ppm - 0 ... 2 % <sup>1)</sup>	±(5 ppm + 2 % of reading)

### Noise (repeatability) at 370 ppmCO<sub>2</sub>

With no output averaging	±3 ppmCO <sub>2</sub>
With 30 s output averaging	±1 ppmCO <sub>2</sub>

### Long-term stability (see graph 'GMP343 operating conditions')

Easy	±2 % of reading <sup>2)</sup> / year
Moderate	±2 % of reading <sup>2)</sup> / 6 months
Harsh	±2 % of reading <sup>2)</sup> / 3 months

### Warm-up time

To full accuracy ±0.5 %	10 min
To full accuracy	30 min

- 1) Accuracy below 200 ppmCO<sub>2</sub> not specified for 2 % range option.  
2) Always at least ±10 ppmCO<sub>2</sub>.

### Effect on accuracy with temperature compensation

CO <sub>2</sub> range options	0 ... 1000 ppm	0 ... 2 000 - 5000 ppm	0 ... 2 %
-------------------------------	----------------	------------------------	-----------

Temperature °C (°F)	Accuracy (% of reading) <sup>1)</sup>		
+10 ... +40 (+50 ... +104)	±1	±1	±2
+40 ... +60 (+104 ... +140)	±2	±3	±4
-40 ... +10 (-40 ... +50)	±3	±3	±5

- 1) Always at least ±10 ppmCO<sub>2</sub>.  
Temperature compensation is performed by an integrated Pt1000 element.

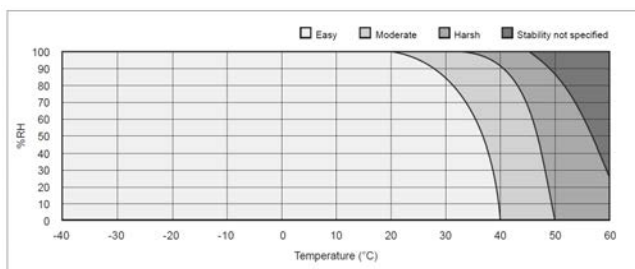

## GMP343 operating conditions

### Effect on accuracy with pressure compensation

CO <sub>2</sub> range options	0 ... 1000 ppm	0 ... 2000 - 2 %
-------------------------------	----------------	------------------

Pressure (hPa)	Accuracy (% of reading)	
900 ... 1050	±0.5	±1
700 ... 1300	±1	±2

Integrated pressure sensor **not** included in GMP343.

## Response time (90 %)

### Diffusion model

Filter attached	Averaging (s)	Response (s)
Yes	0	75
Yes	30	82
No	0	4
No	30	30

### Flow-through model

Gas flow (l/min)	Averaging (s)	Response (s)
0.3	0	26
0.3	30	44
1.2	0	8
1.2	30	23

## Operating environment

Operating temperature	-40 ... +60 °C (-40 ... +140 °F)
-----------------------	----------------------------------

Storage temperature	-40 ... +70 °C (-40 ... 158 °F)
---------------------	---------------------------------

Operating humidity	See graph 'GMP343 operating conditions'
--------------------	---

Compensated pressure range	700 ... 1300 hPa
----------------------------	------------------

Operating pressure	< 5 bar
--------------------	---------

Gas flow for flow-through model	0 ... 10 liters/min
---------------------------------	---------------------

EMC compliance	IEC/EN 61326-1, Basic environment <sup>1)</sup>
----------------	---

- 1) Compliance with IEC/EN 61000-4-3: At 3 V/m RF field test within frequency range 300 ... 400 MHz may cause additional deviation of 150 ppmCO<sub>2</sub>.

## Inputs and outputs

Operating voltage	11 ... 36 VDC
-------------------	---------------

Power consumption	Without optics heating : < 1 W
-------------------	--------------------------------

With optics heating : < 3.5 W

Digital outputs	RS-485, RS-232
-----------------	----------------

### Analog outputs

Current output range	4 ... 20 mA
----------------------	-------------

Current output resolution	14 bits
---------------------------	---------

Current output maximum load	800 Ω at 24 VDC, 150 Ω at 10 VDC
-----------------------------	----------------------------------

Voltage output range	0 ... 2.5 V, 0 ... 5 V
----------------------	------------------------

Voltage output resolution	14 bits (13 bits with 0 ... 2.5 V)
---------------------------	------------------------------------

Voltage output minimum load	5 kΩ
-----------------------------	------

## Mechanical specifications

Housing	Anodized aluminium
---------	--------------------

Filter cover	PC
--------------	----

Cable connector type	8-pin M12
----------------------	-----------

Weight (probe only)	360 g (12.7 oz)
---------------------	-----------------

### IP rating

Housing (cable attached)	IP67
--------------------------	------

Diffusion filter (weather protection)	IP65
---------------------------------------	------

Diffusion filter (sintered PTFE)	IP66
----------------------------------	------

## Spare parts and accessories

Wall mount bracket	GMP343BRACKET
Mounting flange	GMP343FLANGE
Standard diffusion filter (weather protection, IP65) with filter cover	GMP343FILTER
Diffusion filter (sintered PTFE filter, IP66) with filter cover	215521
Calibration adapter (for the diffusion model)	GMP343ADAPTER
Junction box	JUNCTIONBOX-8
<b>Probe cables</b>	
PC connection cable, 2 m (6 ft 7 in)	219687
Interface cable for MI70, 2 m (6 ft 7 in)	DRW216050SP
Soil adapter kit for horizontal positioning	215519
Soil adapter kit for vertical positioning	215520
<b>Cable options</b>	
2 m (6 ft 7 in)	GMP343Z200SP
6 m (19 ft 8 in)	GMP343Z600SP
10 m (32 ft 10 in)	GMP343Z1000SP

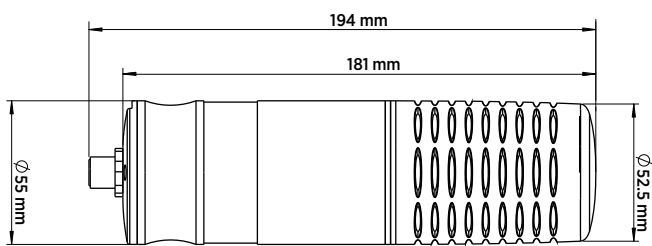

GMP343 dimensions (diffusion model)

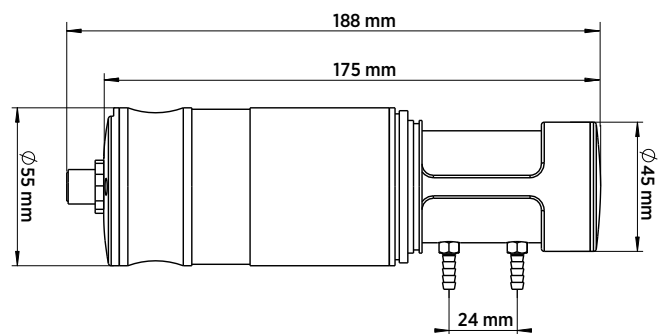

GMP343 dimensions (flow-through model)

## GMP231 Carbon Dioxide Probe For CO<sub>2</sub> incubators



### Features

- Maximum temperature durability +195 °C (+383 °F)
- Incubator can be heat sterilized with probe in place, saving time and reducing risk of cross-contamination
- Heat durability and excellent long-term stability with next generation CARBOCAP® sensor
- Designed for OEM use in CO<sub>2</sub> incubators – installation options available
- CO<sub>2</sub> sensor measurement optimized for 5 % CO<sub>2</sub>, measurement range up to 20 % CO<sub>2</sub>
- 4-point traceable calibration for CO<sub>2</sub>

Vaisala CARBOCAP® Carbon Dioxide Probe GMP231 withstands high temperature sterilization.

GMP231 is designed to provide incubator manufacturers with accurate and reliable carbon dioxide measurements and sterilization durability at high temperatures. The probe is based on Vaisala's patented CARBOCAP® technology and a new type of infrared (IR) light source. These technologies allow for continuous sterilization temperatures of up to 180 °C (+356 °F), enabling easier and more complete sterilization without the risk of cross-contamination. Maximum temperature durability of +195 °C (+383 °F) provides a comfortable operating margin.

The probe is installed through the incubator wall, ensuring that only the IR sensor and optical components are exposed to the incubation

environment. This allows the incubator to be sterilized with the probe in place, removing the need to decontaminate the probe separately. This saves time and reduces the risk of contamination.

The probe's sensor performance is optimized at 5 %CO<sub>2</sub>, but the sensor measures CO<sub>2</sub> up to 20 % with high accuracy. In addition, GMP231 can measure pressure and temperature for CO<sub>2</sub> measurement compensation purposes, ensuring the product remains stable and accurate in all CO<sub>2</sub> incubation conditions. The sensor is made of highly durable materials to achieve outstanding stability over both time and temperature.

Since water vapor, dust, and most chemicals do not affect measurements, GMP231 module is ideal for CO<sub>2</sub> incubator environments.

### Benefits

- Internal pressure and temperature measurement improves accuracy and stability
- Full temperature and pressure compensations available
- Sensor head heating for condensation prevention

# Technical Data

## Measurement performance

Measurement range	0 ... 20 %CO <sub>2</sub>
Calibration uncertainty at 5 %CO <sub>2</sub>	±0.1 %CO <sub>2</sub>
Start-up time	< 20 s
Warm-up time for full spec.	< 3 min
<b>Response time</b>	
T63	< 30 s
T90	< 50 s
<b>Accuracy at 37 °C, 1013 hPa</b>	
Repeatability at:	
0 ... 8 %CO <sub>2</sub>	±0.1 %CO <sub>2</sub>
8 ... 12 %CO <sub>2</sub>	±0.2 %CO <sub>2</sub>
12 ... 20 %CO <sub>2</sub>	±0.4 %CO <sub>2</sub>
Non-linearity at 0 ... 20 %CO <sub>2</sub>	±0.1 %CO <sub>2</sub>
<b>Temperature dependence</b>	
With compensation at 3 ... 12 %CO <sub>2</sub> , 20 ... 60 °C	±0.1 %CO <sub>2</sub>
Without compensation (typical)	-0.4 % of reading/°C
<b>Pressure dependence</b>	
With compensation at 3 ... 12 %CO <sub>2</sub> , 700 ... 1100 hPa	±0.015 % of reading/hPa
Without compensation (typical)	+0.15 % of reading/hPa
<b>Humidity dependence</b>	
With compensation at 0 ... 20 %CO <sub>2</sub> , 0 ... 100 %RH	±0.9 % of reading (at 37 °C)
Without compensation (typical)	+0.05 % of reading/%RH
<b>O<sub>2</sub> dependence</b>	
With compensation at 0 ... 20 %CO <sub>2</sub> , 0 ... 90 %O <sub>2</sub>	±0.6 % of reading
Without compensation (typical)	-0.08 % of reading/%O <sub>2</sub>
<b>Long-term stability</b>	
0 ... 8 %CO <sub>2</sub>	< ±0.2 %CO <sub>2</sub> /year
8 % ... 12 %CO <sub>2</sub>	< ±0.5 %CO <sub>2</sub> /year
12 % ... 20 %CO <sub>2</sub>	< ±1.0 %CO <sub>2</sub> /year

## Mechanical specifications

Connector	M12/8 pin
Weight	150 g (5.29 oz) without cable
IP rating	IP54 (sensor head) IP20 (electronics housing)
<b>Materials</b>	
Housing	Metal coated plastic ABS+PC
Inner tube	Aluminum
Probe tube	PPSU
Filter	PTFE
<b>Dimensions</b>	
Probe tube max. diameter	30.2 mm (1.19 in)
Probe tube length	118.5 mm (4.67 in)
Sensor filter length	12 mm (0.47 in)

## Operating environment

Operating temperature for CO <sub>2</sub> measurement	0 ... +70 °C (+32 ... +158 °F)
Max. temperature durability in standby mode (sensor head only)	Max. +195 °C (+383 °F)
Heat sterilization 180 °C durability	At least 120 cycles
Storage temperature	-40 ... +75 °C (-40 ... +167 °F)
Pressure (compensated)	500 ... 1100 hPa
Pressure (operating)	< 1500 hPa
Humidity	0 ... 100 %, non-condensing
Condensation prevention	Sensor head heating when power on
Chemical tolerance	DMSO, IPA (70 %), H <sub>2</sub> O <sub>2</sub> (2000 ppm, non-condensing), ethanol, acetic acid
Electromagnetic compatibility	EN61326-1, Generic Environment

## Inputs and outputs

Digital outputs	I <sup>2</sup> C 5 V, RS-485 (2-wire with Vaisala Industrial Protocol)
Analog output	0 ... 20 mA (scalable) max. load 600 Ω
Power consumption	< 1 W (pulsed)
Operating voltage	11 ... 30 VDC 20 ... 30 VDC (with analog output)

## Accessories

M12 Connection Cable 0.9 m with open ends	DRW240977SP
M12 Connection Cable 0.6 m with Milli-Grid connector	ASM210903SP
Silicone plug	DRW240015SP
Attachment bracket	DRW240247SP
PTFE filter	DRW240494SP
USB PC connection cable	221040
MI70 connection cable	221801
Calibration adapter for GMP231	239523

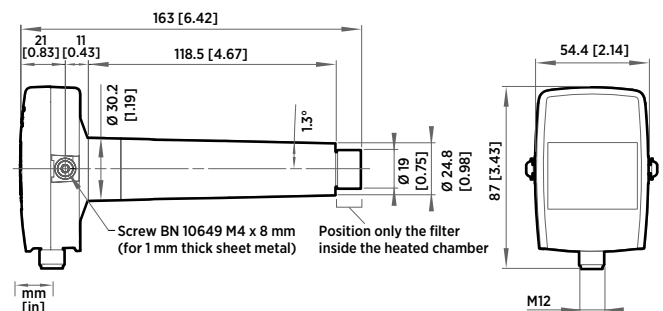

GMP231 dimensions



## GMP251 Carbon Dioxide Probe For %-level measurements



### Features

- Measurement range 0 ... 20 %CO<sub>2</sub>
- Intelligent, standalone probe with analog and digital outputs
- Compatible with Vaisala Indigo products, Insight PC software, and RFL100 data logger
- Wide operating temperature range (-40 ... +60 °C) (-40 ... +140 °F)
- IP65-classified housing
- Integrated temperature measurement for CO<sub>2</sub> compensation purposes
- Compensations also for pressure, oxygen, and humidity
- Sensor head heated to prevent condensation

Vaisala CARBOCAP® Carbon Dioxide Probe GMP251 is an intelligent probe for measuring carbon dioxide. This robust, standalone measurement device is designed for use in demanding applications, such as life science incubators, where stable, reliable, and accurate performance is required.

### Benefits

- Excellent long-term stability
- Reliable and accurate
- Calibration certificate included

GMP251 is based on Vaisala's patented, latest-generation CARBOCAP technology that enables exceptional stability. A new type of infrared (IR) light source is used instead of the traditional incandescent light bulb, which extends the lifetime of GMP251.

GMP251 incorporates an internal temperature sensor for compensation of the CO<sub>2</sub> measurement according to ambient temperature. The effects of pressure and background gas can also be compensated for. The measurement range is 0 ... 20 %CO<sub>2</sub> and the sensor performance is optimized at 5 %CO<sub>2</sub> measurement.

The operating temperature range of the probe is wide (-40 ... +60 °C (-40 ... +140 °F)), and the probe housing is classified as IP65. Condensation is prevented as the internal sensor head is heated. GMP251 is resistant to dust and most chemicals, such as H<sub>2</sub>O<sub>2</sub> and alcohol-based cleaning agents.

### Ease of use

GMP251 is a compact probe with easy and fast plug-in, plug-out installation. The surface of the probe is smooth, which makes it easy to clean. The probe provides several output options, including analog current and voltage outputs and digital RS-485 output with Modbus® protocol.

GMP251 can be connected to Indigo series transmitters and the Indigo80 handheld indicator for an extended range of output and configuration options. See [www.vaisala.com/indigo](http://www.vaisala.com/indigo).

For easy-to-use access to field calibration, device analytics, and configuration functionality, the probe can be connected to Vaisala Insight software for Windows®. See [www.vaisala.com/insight](http://www.vaisala.com/insight).

### Applications

GMP251 is ideal for life science incubators, cold storages, fruit and vegetable transportation, and for all demanding applications where stable and accurate %-level CO<sub>2</sub> measurements are needed.

A flow-through adapter with gas ports is available as an accessory, enabling tubing for easy and flexible remote measurement with a separate pump. A multiplexer can also be added for sampling gas from several locations. <sup>1)</sup>

<sup>1)</sup> Third-party pump and multiplexer not provided by Vaisala.

# Technical data

## Measurement performance

Measurement range	0-20 %CO <sub>2</sub>
<b>Accuracy <sup>1)</sup></b>	
At 5 %CO <sub>2</sub>	±0.1 %CO <sub>2</sub>
At 0-8 %CO <sub>2</sub>	±0.2 %CO <sub>2</sub>
At 8-20 %CO <sub>2</sub>	±0.4 %CO <sub>2</sub>
<b>Calibration uncertainty</b>	
At 5 %CO <sub>2</sub>	±0.07 %CO <sub>2</sub>
At 20 %CO <sub>2</sub>	±0.27 %CO <sub>2</sub>
<b>Long-term stability</b>	
At 0-8 %CO <sub>2</sub>	±0.3 %CO <sub>2</sub> /year
At 8-12 %CO <sub>2</sub>	±0.5 %CO <sub>2</sub> /year
at 12-20 %CO <sub>2</sub>	±1.0 %CO <sub>2</sub> /year
<b>Temperature dependence</b>	
With compensation at 5 %CO <sub>2</sub> , 0 ... +50 °C (+32 ... +122 °F)	< ±0.05 %CO <sub>2</sub>
With compensation, 0-20 %CO <sub>2</sub> , -40 ... +60 °C (-40 ... +140 °F)	±0.045 % of reading/°C
without temperature compensation at 5 %CO <sub>2</sub> (typical)	-0.25 % of reading/°C
<b>Pressure dependence</b>	
With compensation at 5 %CO <sub>2</sub> 700- 1100 hPa	±0.05 %CO <sub>2</sub>
With compensation, 0-20 %CO <sub>2</sub> 500- 1100 hPa	±0.015 % of reading/hPa
Without compensation (typical)	+0.15 % of reading/hPa
<b>Humidity dependence</b>	
With compensation, 0-20 %CO <sub>2</sub> , 0- 100 %RH	±0.7 % of reading (at +25 °C (+77 °F))
Without compensation (typical)	+0.05 % of reading / %RH
<b>O<sub>2</sub> dependence</b>	
With compensation, 0-20 %CO <sub>2</sub> , 0- 90 %O <sub>2</sub>	±0.6 % of reading (at +25 °C (+77 °F))
Without compensation (typical)	-0.08 % of reading / %O <sub>2</sub>
<b>Start-up, warm-up, and response time</b>	
Start-up time at +25 °C (+77 °F)	< 10 s
Warm-up time for full spec.	< 4 min
Response time (T90):	
With standard filter	< 1 min
Flow-through option with > 0.1 l/min	< 1 min
With spray shield	< 2 min
<b>Flow rate dependence (for flow-through option)</b>	
Flow rate dependence:	
< 1 l/min flow	No effect
1-10 l/min flow	< 0.6 % of reading/ l/min

<sup>1)</sup> At 25 °C (77 °F) and 1013 hPa (incl. repeatability and non-linearity).

## Compliance

EU directives and regulations	EMC, RoHS
Electromagnetic compatibility (EMC)	EN 61326-1, basic electromagnetic environment
EMC emissions	CISPR 32 / EN 55032, Class B
Compliance marks	CE, China RoHS, RCM

## Operating environment

Operating temperature of CO <sub>2</sub> measurement	-40 ... +60 °C (-40 ... +140 °F) <sup>1)</sup>
Storage temperature	-40 ... +70 °C (-40 ... +158 °F)
Humidity	0-100 %RH, non-condensing
Condensation prevention	Sensor head heating, when power on
IP rating, probe body	IP65
Chemical tolerance (temporary exposure during cleaning)	<ul style="list-style-type: none"> <li>• H<sub>2</sub>O<sub>2</sub> (2000 ppm, non-condensing)</li> <li>• Alcohol-based cleaning agents (for example ethanol and IPA)</li> <li>• Acetone</li> <li>• Acetic acid</li> </ul>
<b>Pressure</b>	
Compensated	500-1100 hPa
Operating	< 1.5 bar
<b>Gas flow (for flow-through option)</b>	
Operating range	< 10 l/min
Recommended range	0.1-0.8 l/min

<sup>1)</sup> Occasional short-term exposure to up to +90 °C (+194 °F) allowed, provided that the probe is fully installed inside the measured condition and power is switched on. Accuracy specification not applicable if used in temperatures above +60 °C (+140 °F).

## Mechanical specifications

Weight, probe	45 g (1.59 oz)
Connector type	M12 5-pin male
<b>Materials</b>	
Probe housing	PBT polymer
Filter	PTFE membrane, PBT polymer grid
Connector	Nickel plated brass
<b>Dimensions</b>	
Probe diameter	25 mm (0.98 in)
Probe length	96 mm (3.78 in)

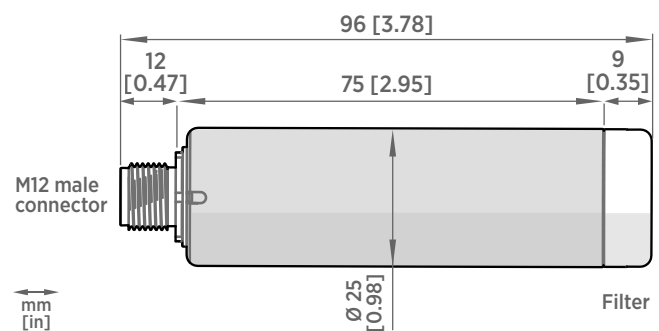

GMP251 dimensions

## Inputs and outputs

Analog outputs	<ul style="list-style-type: none"> <li>0–5/10 V (scalable), min. load 10 kΩ</li> <li>0/4–20 mA (scalable), max. load 500 Ω</li> </ul>
Digital output	Over RS-485: <ul style="list-style-type: none"> <li>Modbus</li> <li>Vaisala Industrial Protocol</li> </ul>
<b>Operating voltage</b>	
With digital output in use	12–30 V DC
With voltage output in use	12–30 V DC
With current output in use	20–30 V DC
<b>Power consumption</b>	
Typical (continuous operation)	0.4 W
Maximum	0.5 W

## Spare parts and accessories

Standard membrane filter	ASM211650SP
Porous sintered PTFE filter	DRW243649SP
Probe connection cable with open wires (1.5 m), shielded	223263SP
Probe connection cable with open wires (1.5 m), shielded	254294SP
Probe connection cable with open wires (3 m), shielded	26719SP
Probe connection cable with open wires (10 m), shielded	216546SP
Probe connection cable with open wires and 90° plug (0.6 m), shielded	244669SP
Probe connection cable with open wires and 90° plug (1.5 m), shielded	255102
MI70 connection cable, M12 5-pin	CBL210472
Connection cable for Indigo80, M12-5F - M12-5M, 1.5 m	272075SP
Flat cable for GMP250 probes, M12 5-pin	CBL210493SP
Indigo USB adapter <sup>1)</sup>	USB2
Probe mounting clips (2 pcs)	243257SP
Probe mounting flange	243261SP
Probe holder assembly	ASM213582
Flow-through adapter with gas ports	ASM211697SP
Calibration adapter	DRW244827SP
Spray shield	ASM212017SP

<sup>1)</sup> Vaisala Insight software for Windows available at [vaisala.com/insight](http://vaisala.com/insight)

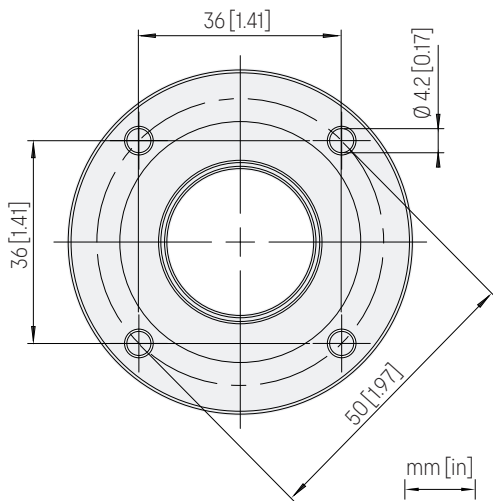

Probe mounting flange 243261SP dimensions

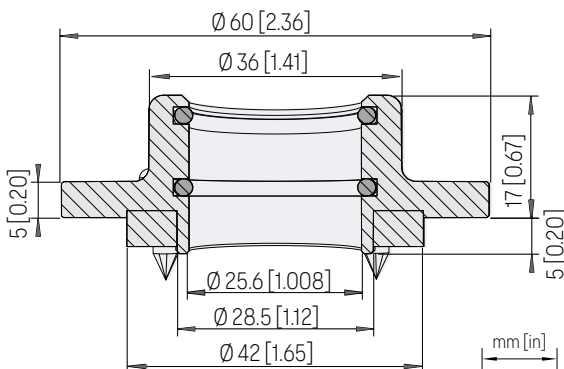

Probe mounting flange 243261SP dimensions, cross section

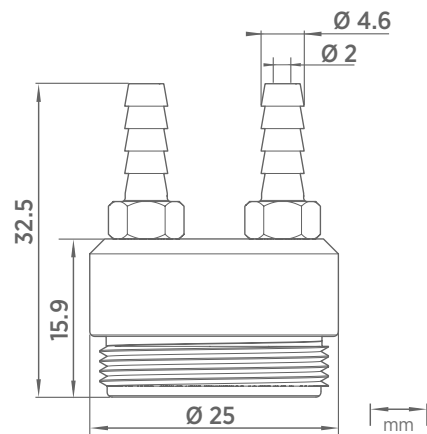

Flow-through adapter with gas ports ASM211697SP. Suitable for tubes with 4 mm inner diameter.

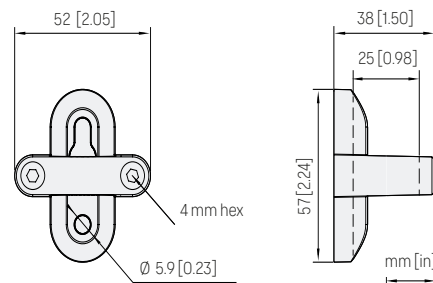

Probe holder ASM213582 dimensions

## GMP252 Carbon Dioxide Probe For ppm-level measurements



### Features

- Measurement range  
0 ... 10 000 ppm CO<sub>2</sub>
- Intelligent, standalone probe with analog and digital outputs
- Compatible with Vaisala Indigo products and Insight PC software
- Wide operating temperature range, -40 ... +60 °C (-40 ... +140 °F)
- IP65-classified housing
- Integrated temperature measurement for CO<sub>2</sub> compensation purposes
- Compensations also for pressure, oxygen, and humidity
- Sensor head heated to prevent condensation

Vaisala CARBOCAP® Carbon Dioxide Probe GMP252 is an intelligent probe for measuring carbon dioxide. This robust, standalone measurement device is designed for use in agriculture, refrigeration, greenhouses, and demanding HVAC applications.

### Benefits

- Excellent long-term stability
- Reliable and accurate
- Calibration certificate included

GMP252 is suitable for harsh and humid CO<sub>2</sub> measurement environments where stable and accurate ppm-level CO<sub>2</sub> measurements are needed. GMP252 is based on Vaisala's patented, latest-generation CARBOCAP technology that enables exceptional stability. A new type of infrared (IR) light source is used instead of the traditional incandescent light bulb, which extends the lifetime of GMP252.

GMP252 incorporates an internal temperature sensor for compensation of the CO<sub>2</sub> measurement according to ambient temperature. The effects of pressure and background gas can also be compensated for. The measurement

range is 0 ... 10 000 ppm CO<sub>2</sub> (measurements up to 30 000 ppm CO<sub>2</sub> are available with reduced accuracy). The operating temperature range of the probe is wide (-40 ... +60 °C (-40 ... +140 °F)), and the probe housing is classified as IP65. Condensation is prevented as the internal sensor head is heated.

GMP252 is resistant to dust and most chemicals, such as H<sub>2</sub>O<sub>2</sub> and alcohol-based cleaning agents.

### Ease of use

GMP252 is a compact probe with easy and fast plug-in, plug-out installation. The surface of the probe is smooth, which makes it easy to clean. The probe provides several output options, including analog current and voltage outputs and digital RS-485 output with Modbus® protocol.

GMP252 can be connected to Indigo series transmitters and the Indigo80 handheld indicator for an extended range of outputs and configuration options. See [www.vaisala.com/indigo](http://www.vaisala.com/indigo).

For easy-to-use access to field calibration, device analytics, and configuration functionality, the probe can be connected to Vaisala Insight software for Windows®. See [www.vaisala.com/insight](http://www.vaisala.com/insight).

### Applications

GMP252 is ideal for agriculture, refrigeration, greenhouses, and demanding HVAC applications where stable and accurate ppm-level CO<sub>2</sub> measurements are needed.

A flow-through adapter with gas ports is available as an accessory, enabling tubing for easy and flexible remote measurement with a separate pump. A multiplexer can also be added for sampling gas from several locations. <sup>1)</sup>

<sup>1)</sup> Third-party pump and multiplexer not provided by Vaisala.

# Technical data

## Measurement performance

Measurement range	0–10 000 ppm CO <sub>2</sub> (up to 30 000 ppm CO <sub>2</sub> with reduced accuracy)
<b>Accuracy</b> <sup>1)</sup>	
0–3000 ppm CO <sub>2</sub>	±40 ppm CO <sub>2</sub>
3000–10 000 ppm CO <sub>2</sub>	±2 % of reading
Up to 30 000 ppm CO <sub>2</sub>	±3.5 % of reading
<b>Calibration uncertainty</b>	
at 2000 ppm CO <sub>2</sub>	±31 ppm CO <sub>2</sub>
at 10 000 ppm CO <sub>2</sub>	±105 ppm CO <sub>2</sub>
<b>Long-term stability</b>	
0–3000 ppm CO <sub>2</sub>	±60 ppm CO <sub>2</sub> /year
3000–6000 ppm CO <sub>2</sub>	±150 ppm CO <sub>2</sub> /year
6000–10 000 ppm CO <sub>2</sub>	±300 ppm CO <sub>2</sub> /year
<b>Temperature dependence 0–10 000 ppm CO<sub>2</sub></b>	
With compensation, –10 ... +50 °C	±0.05 % of reading/°C
With compensation, –40 ... +60 °C	< ±0.1 % of reading/°C
Without temperature compensation at 2000 ppm CO <sub>2</sub> (typical)	–0.5 % of reading/°C
<b>Pressure dependence</b>	
With compensation at 0–10 000 ppm CO <sub>2</sub> , 500–1100 hPa	±0.015 % of reading/hPa
Without compensation (typical)	+0.15 % of reading/hPa
<b>Humidity dependence</b>	
With compensation, 0–10 000 ppm CO <sub>2</sub> , 0–100 %RH	±0.7 % of reading (at +25 °C (+77 °F))
Without compensation (typical)	+0.05 % of reading/%RH
<b>O<sub>2</sub> dependence</b>	
With compensation, 0–10 000 ppm %CO <sub>2</sub> , 0–90 %O <sub>2</sub>	±0.6 % of reading (at +25 °C (+77 °F))
Without compensation (typical)	–0.08 % of reading/%O <sub>2</sub>
<b>Start-up, warm-up, and response time</b>	
Start-up time at +25 °C	< 12 s
Warm-up time for full spec.	< 2 min
Response time (T90):	
With standard filter	< 1 min
Flow-through option with > 0.1 l/min	30 s
With spray shield	< 3 min
<b>Flow rate dependence (for flow-through option)</b>	
< 1 l/min flow	No effect
1–10 l/min flow	< 0.6 % of reading l/min

<sup>1)</sup> At 25 °C (77 °F) and 1013 hPa (incl. repeatability and non-linearity).

## Inputs and outputs

Analog outputs	<ul style="list-style-type: none"> <li>0–5/10 V (scalable), min. load 10 kΩ</li> <li>0/4–20 mA (scalable), max. load 500 Ω</li> </ul>
Digital output	Over RS-485: <ul style="list-style-type: none"> <li>Modbus</li> <li>Vaisala Industrial Protocol</li> </ul>
<b>Operating voltage</b>	
With digital output in use	12–30 V DC
With voltage output in use	12–30 V DC
With current output in use	20–30 V DC
<b>Power consumption</b>	
Typical (continuous operation)	0.4 W
Maximum	0.5 W

## Operating environment

Operating temperature of CO <sub>2</sub> measurement	–40 ... +60 °C (–40 ... +140 °F)
Storage temperature	–40 ... +70 °C (–40 ... +158 °F)
Operating humidity	0–100 %RH, non-condensing
Condensation prevention	Sensor head heating when power on
IP rating, probe body	IP65
Chemical tolerance (temporary exposure during cleaning)	<ul style="list-style-type: none"> <li>H<sub>2</sub>O<sub>2</sub> (2000 ppm, non-condensing)</li> <li>Alcohol-based cleaning agents (for example ethanol and IPA)</li> <li>Acetone</li> <li>Acetic acid</li> </ul>
<b>Pressure</b>	
Compensated	500–1100 hPa
Operating	< 1.5 bar
<b>Gas flow (for flow-through option)</b>	
Operating range	< 10 l/min
Recommended range	0.1–0.8 l/min

## Compliance

EU directives and regulations	EMC, RoHS
Electromagnetic compatibility (EMC)	EN 61326-1, basic electromagnetic environment
EMC emissions	CISPR 32 / EN 55032, Class B
Compliance marks	CE, RCM

## Mechanical specifications

Weight, probe	58 g (2.05 oz)
Connector type	M12 5-pin male
<b>Materials</b>	
Probe housing	PBT polymer
Filter	PTFE
Connector	Nickel-plated brass
<b>Dimensions</b>	
Probe diameter	25 mm (0.98 in)
Probe length	130 mm (5.12 in)

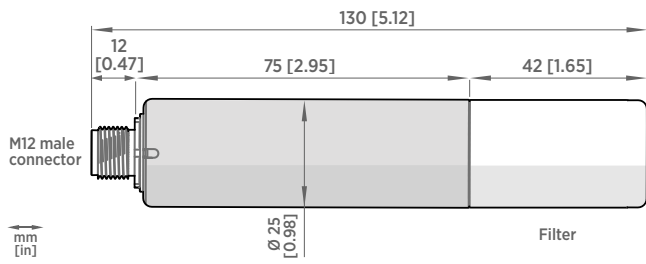

GMP252 probe dimensions

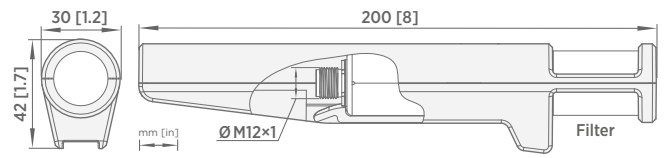

GMP252 probe handle dimensions

## Spare parts and accessories

Porous sintered PTFE filter for GMP252	DRW244221SP
Probe connection cable with open wires (1.5 m), shielded	223263SP
Probe connection cable with open wires (1.5 m), shielded	254294SP
Probe connection cable with open wires (3 m), shielded	26719SP
Probe connection cable with open wires (10 m), shielded	216546SP
Probe connection cable with open wires and 90° plug (0.6 m), shielded	244669SP
Probe connection cable with open wires and 90° plug (1.5 m), shielded	255102
M170 connection cable, M12 5-pin	CBL210472
Connection cable for Indigo80, M12-5F - M12-5M, 1.5 m	272075SP
Flat cable for GMP250 probes, M12 5-pin	CBL210493SP
Indigo USB adapter <sup>1)</sup>	USB2
Probe mounting clips (2 pcs)	243257SP
Probe mounting flange	243261SP
Probe holder assembly	ASM213582
Probe handle with magnetic hanger	GMP252HANDLESP
Probe handle	ASM214342SP
Flow-through adapter with gas ports	ASM212011SP
Calibration adapter	DRW244827SP
Spray shield	ASM212017SP
Radiation shield DTR250	DTR250
Radiation shield DTR250 with pole mounting kit	DTR250A

<sup>1)</sup> Vaisala Insight software for Windows is available at [www.vaisala.com/insight](http://www.vaisala.com/insight).

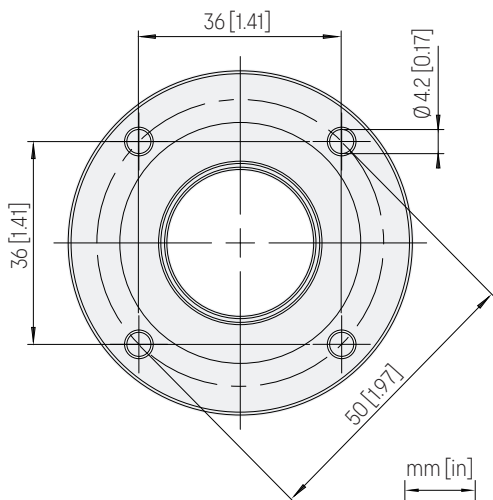

Probe mounting flange 243261SP dimensions

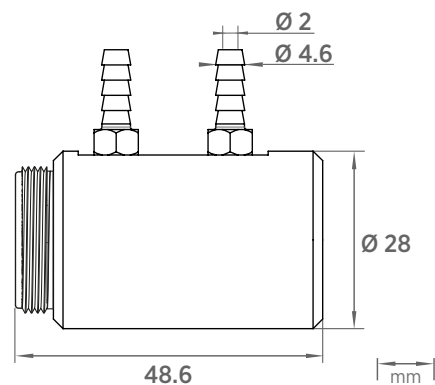

Flow-through adapter with gas ports ASM212011SP. Suitable for tubes with 4 mm inner diameter.



## GMP80P Portable Carbon Dioxide Probe

With pump sampling



### Features

- Measurement range 0–20 %CO<sub>2</sub>
- Operating temperature range +15 ... +40 °C (+59 ... +104 °F)
- Easy CO<sub>2</sub> sampling through standard incubator sampling ports
- Stainless steel pipe and plastic tube options for sampling
- Compatible with Vaisala Indigo80 Handheld Indicator and Insight PC software
- Excellent long-term stability
- Reliable and accurate
- Calibration certificate included

Vaisala CARBOCAP® Portable Carbon Dioxide Probe with Pump Sampling GMP80P combines intelligent CO<sub>2</sub> measurement with pump-aspirated sampling functionality.

This robust and portable measurement device is designed for use in demanding applications, such as life science incubators, where stable, reliable, and accurate performance is required.

### GMP80P is ideal for:

- CO<sub>2</sub> sampling from incubators
- Spot-checking fixed CO<sub>2</sub> transmitters
- Sampling from areas otherwise difficult to access

### Ease of use with Indigo80

CO<sub>2</sub> measurement data can be monitored with the compact Vaisala Indigo80 Handheld Indicator connected to GMP80P. Indigo80 can be used for short-time logging of measurement data, as well as for calibrating and adjusting GMP80P.

Indigo80 has two cable ports for connecting Vaisala probes or transmitters to the indicator for measuring a wide range of parameters. GMP80P is powered by Indigo80, which can supply power for up to two GMP80P probes.

For more information on Indigo80, see [vaisala.com/indigo80](https://vaisala.com/indigo80).

### Flexible connectivity

For easy access to field calibration, device analytics, configuration functionality, and powering, GMP80P can also be connected to a PC running Vaisala Insight PC software for Windows®. For more information on Insight, see [vaisala.com/insight](https://vaisala.com/insight).

### Applications

GMP80P is ideal for life science incubators and for all demanding applications where stable and accurate percentage-level measurements are needed.



# Technical data

## Measurement performance

Measurement range	0–20 %CO <sub>2</sub>
<b>Accuracy</b> <sup>1) 2)</sup>	
At 5 %CO <sub>2</sub>	±0.1 %CO <sub>2</sub>
At 0–8 %CO <sub>2</sub>	±0.2 %CO <sub>2</sub>
At 8–20 %CO <sub>2</sub>	±0.4 %CO <sub>2</sub>
<b>Calibration uncertainty</b>	
At 5 %CO <sub>2</sub>	±0.07 %CO <sub>2</sub>
At 20 %CO <sub>2</sub>	±0.27 %CO <sub>2</sub>
<b>Long-term stability</b>	
At 0–8 %CO <sub>2</sub>	±0.3 %CO <sub>2</sub> /year
At 8–12 %CO <sub>2</sub>	±0.5 %CO <sub>2</sub> /year
At 12–20 %CO <sub>2</sub>	±1.0 %CO <sub>2</sub> /year
<b>Start-up, warm-up, and response time</b>	
Start-up time at +25 °C (+77 °F)	< 10 s
Warm-up time to full specification	< 4 min
Response time (T90)	< 1 min
<b>Other</b>	
Sampling frequency	1 s

1) At 25 °C (77 °F) and 1013 hPa (incl. repeatability and non-linearity).

2) As the gas sample dries during the sampling process, the CO<sub>2</sub> concentration of the dry sample will be higher than in the wet sample taken in the measurement environment. This is due to water condensing off the warm gas sample as it cools down. To determine the most accurate measurement values in your sampling environment, see GMP251 and GMP80P User Guide (M211799EN) at docs.vaisala.com for a table listing the dilution coefficients for gas samples taken at different temperatures.

## Operating environment

Operating environment	Indoor use
Operating temperature	+15 ... +40 °C (+59 ... +104 °F)
Storage temperature	-20 ... +60 °C (-4 ... +140 °F)
Operating humidity	0–95 %RH
Storage humidity	20–85 %RH
IP rating	IP4X
Flow rate of sampled/aspirated gas	0.3 l/min

## Powering

Operating voltage	12–30 V DC
Power consumption	Typical: 0.7 W Maximum: 0.9 W
Current consumption	60 mA typical at minimum voltage

## Digital communication

Digital output	RS-485
----------------	--------

## Compliance

EU directives and regulations	EMC Directive (2014/30/EU) RoHS Directive (2011/65/EU) as amended by 2015/863 REACH Regulation (EC 1907/2006)
Electromagnetic compatibility (EMC)	EN 61326-1, basic electromagnetic environment FCC part 15 B, Class B ICES-3 / NMB-3 (Class B)
Compliance marks	CE, China RoHS, RCM

## Mechanical specifications

Cable connector type	M12 5-pin A-coded male
Barbed fitting for gas outlet (optional)	For tube with ID 4 mm (approx. 5/32 in)
<b>Dimensions (H × W × D)</b>	
Probe body (incl. cable connectors), without sampling pipe:	114 × 102 × 40 mm (4.49 × 4.02 × 1.57 in)
Depth with sampling pipe:	145 mm (5.71 in)
<b>Weight</b>	410 g (14.46 oz)
<b>Materials</b>	
GMP80P (excluding GMP251 probe):	
Housing	Aluminum and polyamide
Sampling pipe	Stainless steel
Barbed fitting for gas outlet	Nickel-plated brass
Connectors (on the bottom)	Nickel-plated brass
GMP251 probe:	
Housing	PBT polymer
Filter	PTFE membrane, PBT polymer grid
Connector	Nickel-plated brass

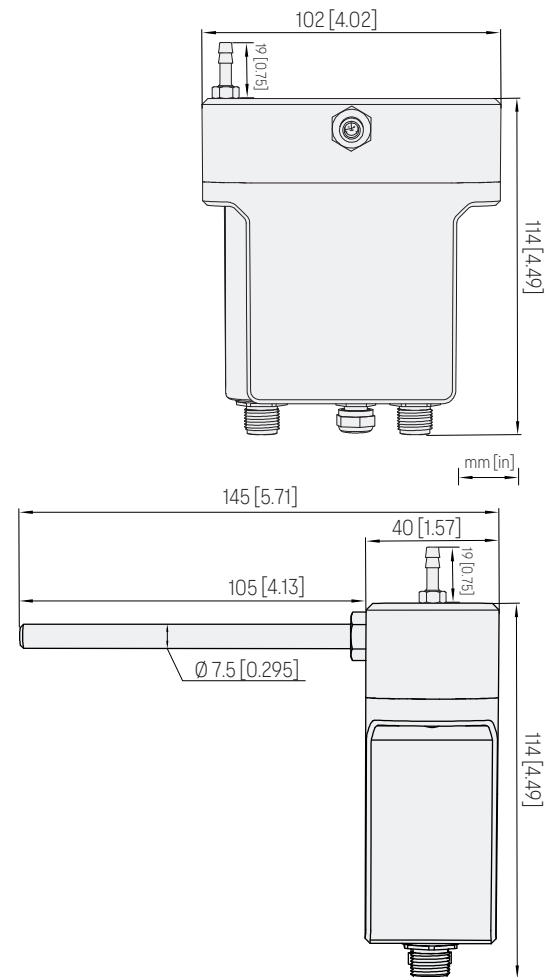

GMP80P dimensions, front and side

## Spare parts and accessories

GMP251 CO <sub>2</sub> probe	Configuration code A1COC0N1 <sup>1)</sup>
Cable for probes (M12-M12), 1.5 m (4 ft 11 in)	272075SP
Sampling pipe (stainless steel), 100 mm (3.94 in)	DRW259158SP
Sampling tube (Nafion™ membrane and PUR), 2.1 m (6 ft 11 in) <sup>2)</sup>	GMTUBESP
Sampling tube (Nafion membrane), 0.6 m (1 ft 12 in)	212807SP
Sampling tube (PUR), 1.5 m (4 ft 11 in)	279471SP
Adapter for sampling tube	279473SP
Barbed fitting for gas outlet	279524SP
Magnetic hanger	ASM214318SP
Indigo USB adapter	USB2

1) See the GMP251 Order Form at [docs.vaisala.com](https://docs.vaisala.com) for more information.

2) Consists of a 0.6-m (1 ft 12 in) Nafion tube and a 1.5-m (4 ft 11 in) polyurethane tube.

## GMW90 Series Carbon Dioxide, Temperature and Humidity Transmitters



### Features

- Measured parameters: carbon dioxide, temperature, and humidity (optional)
- Superior long-term stability with the latest-generation Vaisala CARBOCAP® sensor
- Accurate temperature and humidity measurements due to the low-power microglow infrared source
- Quick and easy installation and maintenance
- Calibrated, user-exchangeable measurement modules
- 3-point traceable CO<sub>2</sub> calibration (certification included)
- Both analog and field bus communication (Modbus® RTU)

GMW90 series transmitters are available with either a display opening or a solid front. An optional traffic light indication is also available.

GMW90 Series CARBOCAP® Carbon Dioxide, Temperature and Humidity Transmitters for HVAC are based on new measurement technology for improved reliability and stability. With the new technology the transmitter's inspection interval is extended to five years.

Designed for demand controlled ventilation, GMW90 series transmitters measure carbon dioxide and temperature, with the option for humidity measurements. The instruments come with a calibration certificate that meets traceability and compliance requirements.

### Reliability from unique measurement technology

GMW90 series transmitters use advanced Micro-Electro-Mechanical System (MEMS) technology for measuring carbon dioxide. The CARBOCAP® carbon dioxide sensor's continuous reference measurement enables reliable and accurate readings and outstanding long-term stability also in buildings with round-the-clock occupancy.

The latest-generation CARBOCAP® sensor no longer uses an incandescent light bulb, which limits sensor lifetime. This unique sensor consumes very little power compared to other sensors on the market. As a result, instrument self-heating is low and humidity and temperature can be measured correctly.

### Convenient installation

GMW90 series transmitters have been designed for quick and easy installation and maintenance. Every model includes a display for easy startup and convenient maintenance. To protect the sensor from dust and dirt during construction and installation, the units can be cabled with back-plate only. Electronics can be

snapped on later at an appropriate phase in the construction project. DIP switches make it quick and easy to configure the transmitters.

### Easy calibration

Regular instrument maintenance guarantees a long product lifetime. Calibration is easiest done with the exchangeable measurement modules. Sensor traceability and measurement quality is easily maintained by snapping on a new module calibrated at Vaisala factory. The instrument can also be calibrated using a handheld meter or reference gas CO<sub>2</sub> bottle. The service interfaces are easy to reach by simply sliding the cover down. The closed cover keeps the measurement environment stable during calibration and ensures top-quality final result.

# GMW90 dimensions and models

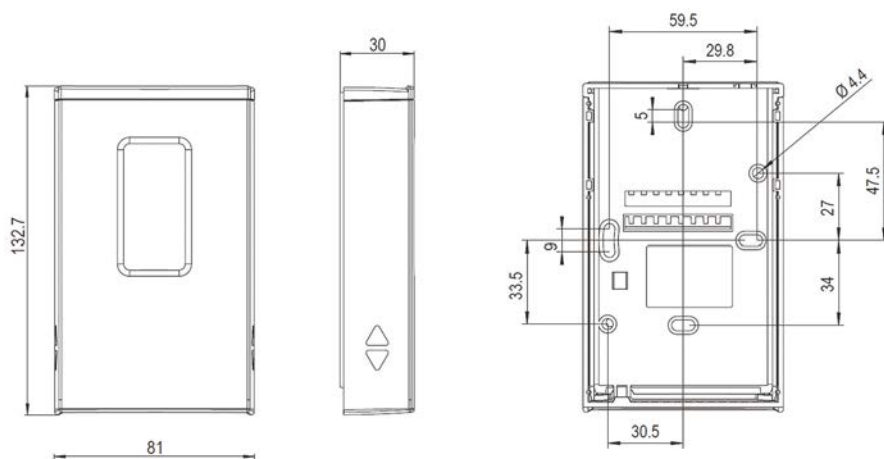

Dimensions (in mm) of GMW90 series transmitter cover (left) and mounting base (right)

## Models

Model	Measurements	Output
GMW93	CO <sub>2</sub> +T	3-wire voltage output
GMW93D	CO <sub>2</sub> +T	3-wire voltage output, with display
GMW94	CO <sub>2</sub> +T	3-wire current output
GMW94D	CO <sub>2</sub> +T	3-wire current output, with display
GMW93R	CO <sub>2</sub> +T+RH	3-wire voltage output
GMW93RD	CO <sub>2</sub> +T+RH	3-wire voltage output, with display
GMW93RA	CO <sub>2</sub> +T+RH	3-wire voltage output, with display and CO <sub>2</sub> indicator LEDs
GMW94R	CO <sub>2</sub> +T+RH	3-wire current output
GMW94RD	CO <sub>2</sub> +T+RH	3-wire current output, with display
GMW95	CO <sub>2</sub> +T	Modbus RTU output
GMW95D	CO <sub>2</sub> +T	Modbus RTU output, with display
GMW95R	CO <sub>2</sub> +T+RH	Modbus RTU output
GMW95RD	CO <sub>2</sub> +T+RH	Modbus RTU output, with display
GMW90	CO <sub>2</sub> +T	Analog or Modbus RTU output (configurable)
GMW90R	CO <sub>2</sub> +T+RH	Analog or Modbus RTU output (configurable)

# Technical data

## Measurement performance

<b>Carbon dioxide</b>	
Measurement range	0 ... 5000 ppm
Stability in typical HVAC applications	Total accuracy at room temperature ±75 ppm at 600 and 1000 ppm incl. 5 years drift
Carbon dioxide sensor	CARBOCAP® GM10
Accuracy:	
+20 ... +30 °C (+68 ... +86 °F)	±(30 ppm + 2 % of reading)
+10 ... +20 °C, +30 ... +40 °C (+50 ... +68 °F, +86 ... +104 °F)	±(35 ppm + 2.7 % of reading)
-5 ... +10 °C, +40 ... +55 °C (+23 ... +50 °F, +104 ... +131 °F)	±(45 ppm + 3.8 % of reading)
<b>Temperature</b>	
Measurement range	-5 ... +55 °C (+23 ... +131 °F)
Temperature sensor	Digital temperature sensor
Accuracy:	
+20 ... +30 °C (+68 ... +86 °F)	±0.5 °C (±0.9 °F)
+10 ... +20 °C, +30 ... +40 °C (+50 ... +68 °F, +86 ... +104 °F)	±0.6 °C (±1.08 °F)
-5 ... +10 °C, +40 ... +55 °C (+23 ... +50 °F, +104 ... +131 °F)	±0.8 °C (± 1.44 °F)
<b>Relative humidity</b>	
Measurement range	0 ... 95 %RH
Stability in typical HVAC applications	±0.5 %RH/year
Humidity sensor	HUMICAP® 180R
Accuracy at temperature range +10 ... +40 °C (+50 ... +104 °F):	
0 ... 60 %RH	±2.5 %RH
60 ... 80 %RH	±3.0 %RH
80 ... 95 %RH	±4.0 %RH
Accuracy at temperature range -5 ... +10 °C, +40 ... +55 °C (+23 ... +50 °F, +104 ... +131 °F):	
0 ... 60 %RH	±3.5 %RH
60 ... 80 %RH	±4.0 %RH
80 ... 95 %RH	±5.0 %RH

1) Complies with CEC-400-2008-001-CMF

## Operating environment

Operating temperature	-5 ... +55 °C (+23 ... +131 °F)
Storage temperature	-30 ... +60 °C (-22 ... +140 °F)
Operating humidity	0 ... 95 %RH Dew point < +30 °C (+86 °F)
IP rating	IP30



Optional decorative cover blends the transmitter into your interior design.

## Inputs and outputs

Supply voltage	18 ... 35 V DC, 24 V AC ± 20% 50/60 Hz
Service port	RS-485 line for temporary service use
<b>Current output models</b>	
Outputs	0/4 ... 20 mA, 2 and 3 channel models
Loop resistance	0 ... 600 Ω
Power consumption	< 2 W
<b>Voltage output models</b>	
Outputs	0 ... 5/10 V, 2 and 3 channel models
Load resistance	10 kΩ min.
Power consumption	< 1 W
<b>Default analog scales</b>	
CO <sub>2</sub>	0 ... 2000 ppm
T	-5 ... +55 °C
RH	0 ... 100 %RH
<b>Field bus models</b>	
Power consumption	< 1.5 W
Output type	RS-485 (galvanic isolation, 1.5 kV)
RS-485 end of line termination	Enable with jumper, 120 Ω
Modbus RTU address range	0 ... 247

## Mechanical specifications

Standard housing color	White (RAL9003)
Housing material	ABS/PC, UL-V0 approved
Output connector	Screw terminals Max. wire size 2 mm <sup>2</sup> (AWG14)
Service port connector	4-pin M8
Weight	163 g (5.75 oz)

1) RAL code is only indicative with potential small variations in color shade

## Spare parts and accessories

CO <sub>2</sub> module	GM10SP
Temperature module (CO <sub>2</sub> +T models)	TM10SP
Humidity and temperature module (CO <sub>2</sub> +T+RH models)	HTM10SP
Decorative cover set (10 pcs)	236285
Connection cable for MI70	219980
USB cable for PC connection	219690
Universal AC power supply	245866

## Compliance

EU directives and regulations	EMC, RoHS
Electromagnetic compatibility (EMC)	EN 61326-1, industrial environment
EMC emissions	CISPR 22 / EN 55022, Class B
Compliance marks	CE, RCM

## GMW80 Series Carbon Dioxide, Humidity, and Temperature Transmitters for DCV



### Features

- Superior stability with the advanced proprietary CARBOCAP® technology
- Improved accuracy due to low self-heating of microglow light source
- Modbus® RTU support over RS-485 with model GMW87

Vaisala CARBOCAP® Carbon Dioxide, Humidity, and Temperature Transmitter Series GMW80 is based on Vaisala's patented latest-generation CARBOCAP technology with improved reliability and stability.

The GMW80 series transmitters are designed to fulfill the needs for CO<sub>2</sub> measurements in standard demand-controlled ventilation applications. Temperature measurement is included in most GMW80 series transmitters. Combined with humidity measurement, relay, and LED CO<sub>2</sub> level indication, GMW80 series provides you the flexibility needed for a variety of projects.

The CARBOCAP sensors measure CO<sub>2</sub> accurately immediately when powered on. As they have a built-in reference measurement they do not need a lengthy learning phase before the measured values are correct. Proper operation can be verified immediately after snapping on the device cover.

### Easy installation

With modern buildings often having hundreds of sensors, installation time per unit can be a significant cost factor. Returning to the building site to check sensor operation adds further costs. The GMW80 series transmitters include a number of subtle design features that have been introduced to make installation and commissioning quick and easy.

The pull-out tab makes opening the transmitter faster than before, while also doubling as a quality check slip and holder for the anti-tamper screw. The backplate can be twisted onto pre-mounted screws, and the wiring can be done easily on the clearly marked backplate. The electronics can be snapped on later when the building automation system is commissioned.

For measurements in more demanding conditions (for example, dusty or humid installation locations), the GMW87 and GMW88 models provide an IP64-rated enclosure with a cable gland.

### Reliable operation

The GMW80 series transmitters are optimized for low maintenance. The unique, low-power CARBOCAP technology enables a longer lifetime and better stability than ever before. As the power consumption is low, the heat generated by the electronics does not distort the temperature inside the sensor. The internal reference in the CO<sub>2</sub> sensor guarantees superior stability and flawless operation even in constantly occupied buildings, without the need for frequent readjustments.

The reliable operation and accurate measurement values of the GMW80 series transmitters contribute to the significant cost savings brought by demand-controlled ventilation.

### Benefits

- Cost-efficient, affordable
- Reliable and maintenance-free operation for up to 15 years
- Easy to install, easy to use
- Versatile – works well in buildings occupied 24/7
- Ideal for demand-controlled ventilation

# Technical data

## Models

Model	Meas. parameters	Output	CO <sub>2</sub> range (ppm)
GMW86P	CO <sub>2</sub> +T	Current and voltage output, Pt1000	0 ... 2000
GMW83RP <sup>1)</sup>	CO <sub>2</sub> +RH+T	Voltage outputs, Pt1000	0 ... 2000
GMW83DRP <sup>1)</sup>	CO <sub>2</sub> +RH+T	Voltage outputs, Pt1000, display with metric scale output	0 ... 2000
GMW83	CO <sub>2</sub> +T	Voltage outputs	0 ... 2000
GMW83A	CO <sub>2</sub> +T	Voltage outputs, CO <sub>2</sub> indicator LEDs	0 ... 2000
GMW83D	CO <sub>2</sub> +T	Voltage outputs, display with metric scale output	0 ... 2000
GMW84	CO <sub>2</sub> +T	Current output	0 ... 2000
GMW84S	CO <sub>2</sub> +T	Current output, relay	0 ... 2000
GMW87	CO <sub>2</sub>	RS-485 Modbus RTU output	0 ... 5000
GMW88	CO <sub>2</sub>	Current and voltage output	0 ... 2000 / 0 ... 5000 <sup>2)</sup>

<sup>1)</sup> Models with calibration certificate available (GMW83RPC/GMW83DRPC).

<sup>2)</sup> Range user-selectable with dip switch. Default range 0 ... 5000 ppm.

## Measurement performance

Carbon dioxide	
Measurement range	0 ... 2000/5000 ppm (see table <i>Models</i> )
Accuracy <sup>1)</sup> :	
at +20 ... +30 °C (+68 ... +86 °F)	±(30 ppm +3 % of reading)
at +10 ... +20 °C (+50 ... +68 °F) and +30 ... +40 °C (+86 ... +104 °F)	±(35 ppm +3.7 % of reading)
at +0 ... +10 °C (+32 ... +50 °F) and +40 ... +50 °C (+104 ... +122 °F)	±(40 ppm +4.8 % of reading)
Stability in typical HVAC applications	±(15 ppm + 2 % of reading) over 5 years
Warm-up time	1 min 10 min for full specification
Response time (63 %)	60 s 7 min (GMW87 and GMW88)
Carbon dioxide sensor	CARBOCAP® GM10
Temperature	
Measurement range	0 ... +50 °C (+32 ... +122 °F)
Temperature sensor	On P models: Pt1000 RTD Class F0.15 IEC 60751 For analog outputs: Digital temperature sensor
Accuracy (GMW83 and GMW84):	
at +10 ... +30 °C (+50 ... +86 °F)	±0.5 °C (0.9 °F)
at +0 ... +10 °C (+32 ... +50 °F) and +30 ... 50 °C (+86 ... +122 °F)	±1 °C (1.8 °F)
Humidity	
Measurement range	0 ... 95 %RH
Accuracy at temperature range +10 ... +30 °C (+50 ... +86 °F):	
0 ... 80 %RH	±3 %RH
80 ... 95 %RH	±5 %RH
Accuracy at temperature ranges 0 ... +10 °C (+32 ... +50 °F) and +30 ... +50 °C (+86 ... +122 °F):	
0 ... 95 %RH	±7 %RH
Stability in typical HVAC applications	±2 %RH over 2 years
Product lifetime	> 15 years

<sup>1)</sup> Accuracy applicable to 2000 ppm measurements at 1013 hPa pressure. Pressure or temperature dependencies not included in the values.

## Compliance

EU directives and regulations	EMC, RoHS
Electromagnetic compatibility (EMC)	EN 61326-1, industrial environment
Compliance marks	CE, RCM

## Operating environment

Operating temperature	0 ... +50 °C (+32 ... +122 °F)
Operating humidity	0 ... 95 %RH Dew point < 30 °C (+86 °F)
Storage temperature	Models without display: -40 ... +70 °C (-40 ... +158 °F) Models with display: -30 ... +70 °C (-22 ... +158 °F)

## Inputs and outputs

Supply voltage	18 ... 35 V DC 24 V AC $\pm 20\%$ 50/60 Hz
Max. current consumption at 18 V DC	45 mA 70 mA (GMW84 models)
Max. power consumption at 30 V AC	0.7 W (GMW83 models) 1 W (GMW86 models, GMW87, and GMW88) 1.2 W (GMW84 models)
RS-485 interface (in GMW87 only)	Isolated, supports Modbus RTU protocol <ul style="list-style-type: none"> <li>Modbus RTU address range: <ul style="list-style-type: none"> <li>1 ... 247 (up to 255 possible, non-standard)</li> </ul> </li> <li>Bit rates: <ul style="list-style-type: none"> <li>4800, 9600, 19200, 38400, 57600, 76800, 115200</li> </ul> </li> <li>Parity: <ul style="list-style-type: none"> <li>None or Even</li> </ul> </li> <li>Supports automatically both 1 and 2 stop bits</li> </ul>
Outputs	4 ... 20 mA and/or 0 ... 10 V <sup>1)</sup>
Current loop resistance (4 ... 20 mA)	0 ... 600 $\Omega$
Voltage output load resistance	Min. 10 k $\Omega$
CO <sub>2</sub> output scale	0 ... 2000/5000 ppm
Temperature output scale	0 ... +50 °C (+32 ... +122 °F)
Humidity output scale	0 ... 100 %RH
Passive temperature sensor (P models)	Pt1000 RTD
Temperature setpoint (T models)	10 k $\Omega$ potentiometer
Relay (S models)	1 pc, SPST-NO Max. 50 V DC / 50 V AC, 500 mA
CO <sub>2</sub> indicator LED levels (A model)	Flashing red: > 2000 ppm Red: 1200 ... 2000 ppm Yellow: 800 ... 1200 ppm Green: < 800 ppm

1) Analog outputs are not available in model GMW87.

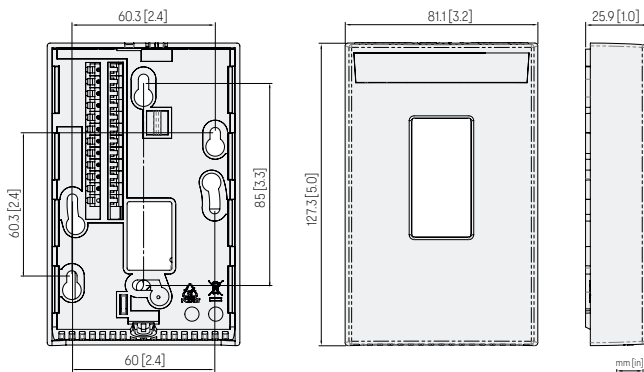

GMW83, GMW83A, GMW83RP, GMW84, GMW84S, GMW86P, GMW83D, and GMW83DRP dimensions (display in models with the letter D)

## Mechanical specifications

IP rating	IP30 IP64 (GMW87 and GMW88)
Housing material	ABS/PC UL-V0 approved PC (GMW87 and GMW88)
Housing color	White (RAL9003)
Output connector	Screw terminal
Max. wire size	2 mm <sup>2</sup> (AWG14)
Weight	Plain and LED version: 114 g (4.02 oz) Display version: 124 g (4.37 oz) GMW87 and GMW88: 160 g (5.64 oz)

## Spare parts and accessories

CO <sub>2</sub> module	GM10SP80
INTERCAP® humidity sensor	15778HM
Universal AC power supply	245866

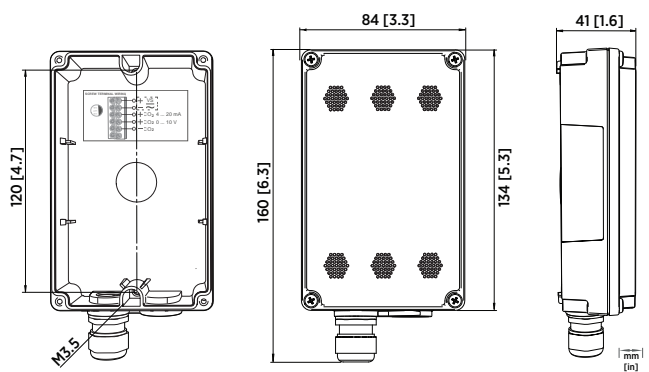

GMW87 and GMW88 dimensions

## GMD110 Duct Carbon Dioxide Transmitter

For demanding ventilation applications



### Features

- Designed for highly reliable CO<sub>2</sub> measurement in air ducts
- Vaisala CARBOCAP® sensor
- ± 40 ppm CO<sub>2</sub> accuracy
- Excellent long-term stability
- Analog and Modbus RTU output options
- IP65-rated housing
- Traceable calibration (certificate included)

GMD110 is a high-accuracy duct transmitter for measuring carbon dioxide in air-handling systems and ventilation ducts. The transmitter is equipped with the renowned CARBOCAP® sensor that has unique accuracy and measurement stability, which supports precise and reliable controls of HVAC systems even in demanding conditions and sites.

The transmitter belongs to Vaisala HMDW110 Transmitter Series, which include transmitters for duct mounting, IP65-rated wall transmitters, immersion temperature transmitters and outdoor transmitters with integrated radiation shields.

### Highly accurate, highly reliable

The duct-mounted transmitter GMD110 is designed to measure carbon dioxide in demanding HVAC applications. With the outstanding accuracy of measurement, it is an ideal choice for demand-controlled ventilation systems even in challenging conditions.

CO<sub>2</sub> concentration is measured inside the duct without risks for leaks or wrong flow direction affecting the measurement. The temperature and flow dependencies of the sensor are negligible, and the measurement accuracy is not affected by dust, water vapor, or chemicals.

### Stable measurement

The high quality and excellent stability of the measurement enables precise and reliable controls of HVAC systems, even in demanding conditions or sites. The transmitter is equipped with the renowned CARBOCAP® sensor that has

unique capabilities in terms of precision and stability of the measurement. Its structure and reference measurement capabilities make this single-beam, dual-wavelength NDIR sensor extremely stable and reliable.

### Traceable accuracy

All GMD110 transmitters are individually adjusted and delivered with a traceable (ISO9001) calibration certificate. If required later on, the transmitter can also be field-calibrated using a Vaisala handheld meter or Vaisala Insight PC software.

# Technical data

## Measurement performance

Measurement range	0 ... 10 000 ppm CO <sub>2</sub> Orderable with analog output scaled to 0 ... 2000 ppm, 0 ... 5000 ppm, or 0 ... 10 000 ppm
<b>Accuracy</b> <sup>1)</sup>	
0 ... 3000 ppm CO <sub>2</sub>	±40 ppm CO <sub>2</sub>
3000 ... 10 000 ppm CO <sub>2</sub>	±2 % of reading
<b>Calibration uncertainty</b>	
at 2000 ppm CO <sub>2</sub>	±31 ppm CO <sub>2</sub> (typical)
at 10 000 ppm CO <sub>2</sub>	±105 ppm CO <sub>2</sub> (typical)
<b>Long-term stability</b>	
0 ... 3000 ppm CO <sub>2</sub>	±60 ppm CO <sub>2</sub> /year
3000 ... 6000 ppm CO <sub>2</sub>	±150 ppm CO <sub>2</sub> /year
6000 ... 10 000 ppm CO <sub>2</sub>	±300 ppm CO <sub>2</sub> /year
<b>Temperature dependence 0 ... 10 000 ppm CO<sub>2</sub></b>	
-10 ... +50 °C	±0.05 % of reading/°C
-40 ... +60 °C	< ±0.1 % of reading/°C
<b>Pressure dependence</b>	
Typical	+0.15 % of reading/hPa
<b>Start-up, warm-up, and response time</b>	
Start-up time at +25 °C	< 12 s
Warm-up time for full specification	< 2 min
Response time (T <sub>90</sub> )	< 1 min

<sup>1)</sup> At 25 °C and 1013 hPa (incl. repeatability and non-linearity).

## Operating environment

Operating temperature	-20 ... +60 °C (-4 ... +140 °F)
Storage temperature	-40 ... +60 °C (-40 ... +140 °F)
Humidity	0 ... 95 %RH, non-condensing
Condensation prevention	Sensor head heating when power on
IP rating	IP65

## Mechanical specifications

Probe diameter	25 mm (0.98 in)
Probe length	126 mm (4.96 in)
Weight	215 g (0.47 lb)
Screw terminal wire size	0.5 ... 2.5 mm <sup>2</sup> (AWG 24 ... 14)
Housing color	White (RAL9003)
Mounting methods	Screws or optional mounting flange 243261SP
<b>Materials</b>	
Probe	PBT polymer
Probe filter	PTFE
Housing	PC + 10 %GF (UL-V0 approved)

## Inputs and outputs

Output parameter	Carbon dioxide (ppm)
Output modes	0/4 ... 20 mA, scalable, max. load 500 Ω 0 ... 5/10 V, scalable, min. load 10 kΩ RS-485 with Modbus RTU
Power consumption	0.5 W typical, 1.1 W max.
<b>Supply voltage</b>	
With current output	20 ... 30 V DC
With voltage output or RS-485	12 ... 30 V DC
<b>Digital communication</b>	
Interface	RS-485, non-isolated, no line termination
Default serial settings	19200 bps N 8 2
Protocol	Modbus RTU
Modbus device address	240
<b>Service port</b>	
Connector	M8 4-pin male
Compatibility	<ul style="list-style-type: none"> <li>Indigo80 handheld indicator<sup>1)</sup></li> <li>MI70 handheld indicator<sup>2)</sup></li> <li>Vaisala Insight PC software<sup>3)</sup></li> </ul>

<sup>1)</sup> Requires M12-M8 cable 262195SP.

<sup>2)</sup> Requires connection cable 219980SP.

<sup>3)</sup> Requires USB adapter USB2 with M12-M8 cable 262195SP. Vaisala Insight software for Windows is available at [www.vaisala.com/insight](http://www.vaisala.com/insight).

## Compliance

EU directives and regulations	EMC Directive (2014/30/EU) RoHS Directive (2011/65/EU) as amended by 2015/863
Electromagnetic compatibility (EMC)	EN 61326-1, basic electromagnetic environment
Compliance marks	CE, RCM

## Accessories and spare parts

Probe mounting flange	243261SP
Conduit fitting + O-ring (M16 × 1.5 / NPT1/2")	210675SP
Conduit fitting + O-ring (M16 × 1.5 / PG9, RE-MS)	210674SP
USB adapter for Insight and M12 - M8 cable	USB2 and 262195SP
Connection cable for GM70 (MI70) handheld meter	219980SP
Calibration adapter	DRW244827SP
Porous sintered PTFE filter	DRW244221SP

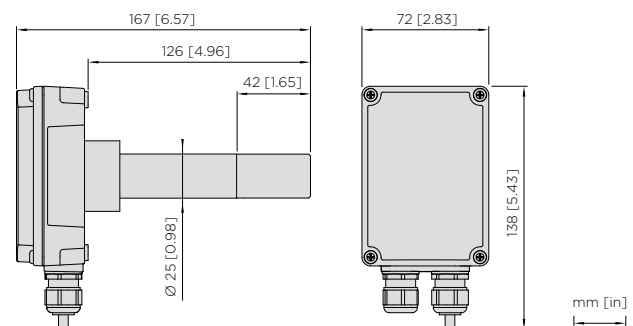

GMD110 dimensions

## MGP261 Multigas Probe

For methane, carbon dioxide, and humidity measurement



### Features

- Compact in situ probe with CH<sub>4</sub>, CO<sub>2</sub>, and H<sub>2</sub>O vapor measurement
- Excellent long-term stability and repeatability with proprietary infrared technology — no calibration gases needed
- Direct installation into process: no sample treatment needed
- Certified for Ex Zone 0/1
- Probe heating eliminates condensation in wet processes
- Corrosion-resistant stainless steel housing (IP66)
- Standalone probe with digital Modbus RTU over RS-485 or 3 analog outputs (4–20 mA)
- Compatible with Vaisala Insight PC software

Vaisala CARBOCAP® MGP261 Multigas Probe for Methane, Carbon Dioxide, and Humidity Measurement is designed for in situ measurements in demanding biogas processing conditions where repeatable, stable, and accurate measurement is essential. MGP261 is Ex-certified for use in Ex Zone 0 (parts inserted into process) and Ex Zone 1 (parts outside the process). The probe belongs to the Vaisala MGP260 series product family.

### Up to three measurements in one compact unit

MGP261 measures the main components of biogas and landfill gas: methane (CH<sub>4</sub>), carbon dioxide (CO<sub>2</sub>), and humidity. These gases make up the bulk of biogas, and measuring all three parameters gives you a 100 % picture of the process. MGP261 measures CH<sub>4</sub>, CO<sub>2</sub>, and humidity in vol-% units, or alternatively dewpoint temperature (T<sub>d</sub>) in degrees Celsius.

### Methane measurement for biogas quality and process control

Methane concentration measurement tells you the calorific value of the gas produced in real time. With internal temperature measurement for

compensation purposes and an option for external pressure or temperature compensation input, the patented CARBOCAP® measurement gives unparalleled stability and reliability without calibration gases. Application areas include anaerobic digestion and landfill gas monitoring, activated carbon filter monitoring in biogas treatment process, and CHP engine feed gas monitoring.

### Direct in situ measurement without sample treatment

MGP261 measures gases directly in the process pipeline without a need for moisture removal. This simplifies the measurement both in situ and as part of an extractive system with optional flow through cell accessory. The heated

optical elements provide reliable measurements even in most demanding process conditions with condensate in the process gas.

MGP261 is Ex-certified for use in Ex Zone 0 (parts inserted into process) and Ex Zone 1 (parts outside the process). The electronics and optics of the IP66-rated instrument are protected by encapsulation in a potting compound to ensure maximum resistance to weather, dust, and ingress of process gases in the probe. Materials exposed to process gas are carefully selected for good chemical resistance against hydrogen sulfide: they include stainless 316L steel and polytetrafluoroethylene (PTFE).

# Technical data

## Measurement performance

Property	Methane CH <sub>4</sub>	Carbon dioxide CO <sub>2</sub>	Water vapor H <sub>2</sub> O
Sensor	CARBOCAP®	CARBOCAP®	CARBOCAP®
Measurement unit	Volume-%	Volume-%	Volume-%, dew point °C
Measurement range	0–100 vol-%	0–100 vol-%	0–25 vol-%, –10 ... +60 °C (14 ... +140 °F)
Accuracy at +25 °C (+77 °F) and 1013 hPa <sup>1) 2)</sup>	<ul style="list-style-type: none"> <li>0–40 vol-%: <b>±2 vol-%</b></li> <li>40–70 vol-%: <b>±1 vol-%</b></li> <li>70–100 vol-%: <b>±2 vol-%</b></li> </ul>	<ul style="list-style-type: none"> <li>0–30 vol-%: <b>±2 vol-%</b></li> <li>30–50 vol-%: <b>±1 vol-%</b></li> <li>50–100 vol-%: <b>±2 vol-%</b></li> </ul>	0–25 vol-%: <b>±0.5 vol-%</b>
Repeatability <sup>2)</sup>	±0.5 vol-% at 60 vol-%	±0.3 vol-% at 40 vol-%	±0.1 vol-% at 2.5 vol-%
Temperature dependence, compensated	Compensated, 0–100 vol-%: ±0.1 % of reading/°C	Compensated, 0–100 vol-%: ±0.1 % of reading/°C	Compensated, 0–25 vol-%: ±0.1 % of reading/°C
Temperature dependence, uncompensated	Uncompensated, 0–100 vol-%: –0.9 % of reading/°C	Uncompensated, 0–100 vol-%: –0.9 % of reading/°C	Uncompensated, 0–25 vol-%: –0.4 % of reading/°C
Pressure dependence, compensated	Compensated, 0–100 vol-%: ±0.015 % of reading/hPa	Compensated, 0–100 vol-%: ±0.01 % of reading/hPa	Compensated, 0–25 vol-%: ±0.06 % of reading/hPa
Pressure dependence, uncompensated	Uncompensated, 0–100 vol-%: +0.2 % of reading/hPa	Uncompensated, 0–100 vol-%: +0.2 % of reading/hPa	Uncompensated, 0–25 vol-%: +0.2 % of reading/hPa
Long-term stability	±2 vol-%/year	±2 vol-%/year	±2 vol-%/year
Start-up time <sup>3)</sup>			30 s
Warm-up time <sup>4)</sup>			2 min <sup>5)</sup>
Response time (T <sub>90</sub> )			90 s <sup>6)</sup>
Response time with flow-through adapter			90 s at ≥ 0.5 l/min <sup>6)</sup> (recommended: 0.5–1 l/min)

<sup>1)</sup> Excluding cross-interferences to other gases.

<sup>2)</sup> Accuracy specification at 25 °C (+77 °F) and 1013 hPa including non-linearity, calibration uncertainty, and repeatability; temperature and pressure compensated.

<sup>3)</sup> Time to first reading

<sup>4)</sup> Time to specified accuracy

<sup>5)</sup> At +20 °C (+68 °F) ambient temperature

<sup>6)</sup> With standard PTFE filter

## Inputs and outputs

Operating voltage	18–30 V DC
Power consumption	Typical: 3 W Maximum: 6 W
Digital output	RS-485 (Modbus RTU)
Analog output	3 × 4–20 mA scalable, isolated
Analog output load	Minimum: 0 Ω Maximum: 500 Ω
Analog output accuracy	±0.2 % of full scale at 25 °C (77 °F)
Analog output temperature dependence	0.005 %/°C (0.003 %/°F) full scale
Analog input (optional)	1 × 4–20 mA (Ex ia) for external pressure or temperature sensor <sup>1)</sup>

<sup>1)</sup> The optional analog input is galvanically isolated and provides power for the connected external pressure sensor.

## Compliance

Electromagnetic compatibility (EMC)	EN 61326-1, industrial environment
Compliance marks	CE, China RoHS, RCM
Ex approval marks	EU (ATEX), international (IECEX), US/CAN (cMETus), Japan (CML), UK(UKEX), Korea (KCs) <sup>1)</sup>
Ex classification	Ex II 1/2 (I) G Ex eb mb [ia] IIB T3 Ga/Gb –40 °C ≤ Tamb ≤ +60 °C Class I, Division 2, Groups C, D; T3

<sup>1)</sup> See product documentation for full Ex classifications for each region.

## Operating environment

Operating temperature range	–40 ... +60 °C (–40 ... +140 °F)
Operating humidity range	0–100 %RH
Storage temperature range	–40 ... +60 °C (–40 ... +140 °F)
Storage humidity range	0–90 %RH
Process pressure range	–500 ... +500 hPa
Process temperature range	+0 ... +60 °C (+32 ... +140 °F)
Process flow range	0–20 m/s

## Mechanical specification

Weight	3 kg (6.6 lb)
Thread type	1.5" male NPT
Mechanical pressure tolerance	20 bar(g)
Cable lead-throughs	1 × M16×1.5 2 × M20×1.5
IP rating	IP66
<b>Materials</b>	
Probe body	AISI316L stainless steel, PPS
Filter cap	Sintered PTFE

## Options and accessories

Configuration cable (RS-485/USB) <sup>1)</sup>	257295
Flow-through adapter	258877
Sintered PTFE filter (includes O-ring)	DRW249919SP
NPT 1.5" thread test plug	257525SP

<sup>1)</sup> Vaisala Insight software for Windows® available at [www.vaisala.com/insight](http://www.vaisala.com/insight)

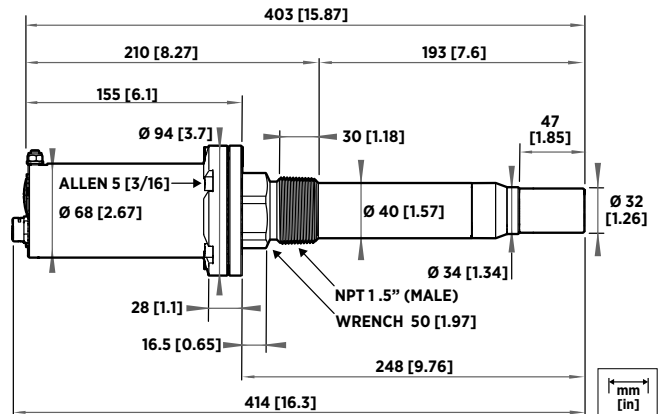

MGP261 dimensions

## MGP262 Multigas Probe

For low concentration methane and high concentration carbon dioxide measurement



### Features

- Compact in situ probe with low-% CH<sub>4</sub> and high-% CO<sub>2</sub> measurement
- Excellent long-term stability and repeatability with proprietary infrared technology — no calibration gases needed
- Direct installation into process: no sample treatment needed
- Certified for Ex Zone 0/1
- Probe heating eliminates condensation in wet processes
- Corrosion-resistant stainless steel housing (IP66)
- Standalone probe with digital Modbus RTU over RS-485 or 3 analog outputs (4–20 mA)
- Compatible with Vaisala Insight PC software

Vaisala CARBOCAP® MGP262 Multigas Probe for Methane and Carbon Dioxide Measurement is designed for demanding in situ measurement of the offgas in the biogas upgrading process, where low concentrations of methane need to be measured reliably and with high accuracy in the presence of high concentrations of carbon dioxide. The probe belongs to the Vaisala MGP260 series product family.

### Direct view to process performance

MGP262 measures the concentrations of the main components in the offgas stream of a biogas upgrading process: methane and carbon dioxide. The methane concentration in the offgas is one of the direct indicators of the process performance. The lower the offgas methane concentration, the lower the methane loss, hence higher yield from the biogas and the smaller the environmental impact. Monitoring offgas composition reliably and accurately enables optimizing the upgrading process as well as determining the amount of greenhouse gases emitted from the process for environmental compliance purposes.

### Outstanding methane measurement performance

MGP262 has been optimized for measuring methane concentrations below 5 vol-% with an accuracy of ±0.15 vol-%. Combined with a wide temperature range (-40 to +60 °C), MGP262 is ideal for a wide range of upgrading technologies and processes.

### Ease of use

MGP262 is unique in being an in situ probe for demanding explosive environments. No sampling system is needed and there are no moving parts in the probe. Apart from an annual calibration check, MGP262 does not need any consumables or calibration gas cylinders, which makes its maintenance very easy.

### Robust, weatherproof, and Ex-certified for Zones 0 and 1

MGP262 is internationally certified for Zone 0 inside the pipeline and Zone 1 on the outside, allowing installation in any Ex hazardous environment expected in the biogas and natural gas industry. The probe is IP66-rated and specified for ambient temperatures from -40 to +60°C for outdoor installation in harsh environments. Stainless-steel construction, hermetic sealing of optics, and encapsulated electronics provide the probe with maximum robustness and resilience to mechanical shocks, vibration, and corrosive chemicals.

# Technical data

## Measurement performance

Property	Methane CH <sub>4</sub>	Carbon dioxide CO <sub>2</sub>
Sensor	CARBOCAP®	CARBOCAP®
Measurement unit		Volume-%
Measurement range	0–5 vol-%	0–100 vol-%
Accuracy at +25 °C (+77 °F) and 1013 hPa <sup>1) 2)</sup>	0–2 vol-%: <b>±0.1 vol-%CH<sub>4</sub></b> 2–5 vol-%: <b>±5% of reading</b>	90–100 vol-%: <b>±1 vol-%</b> 0–90 vol-%: <b>±2 vol-%</b>
Repeatability <sup>2)</sup>	< ±0.1 vol-% at 1% CH <sub>4</sub>	±0.4 vol-% at 95 vol-%
Temperature dependence (typical)	Compensated: 0–2 vol-%: <b>±0.05%CH<sub>4</sub></b> 2–5 vol-%: <b>±0.2%CH<sub>4</sub></b> Uncompensated: <b>±0.7 % of reading / °C</b>	Compensated, 0–100 vol-%: <b>±0.4 vol-%</b> Uncompensated, 0–100 vol-%: <b>±0.1 % of reading / °C</b>
Pressure dependence (typical)	Compensated: 0–2 vol-%: <b>±0.05%CH<sub>4</sub></b> 2–5 vol-%: <b>±0.1%CH<sub>4</sub></b> Uncompensated: <b>±0.2 % of reading / hPa</b>	Compensated, 0–100 vol-%: <b>±1 vol-%CO<sub>2</sub></b> Uncompensated, 0–100 vol-%: <b>±0.15 % of reading / hPa</b>
Long-term stability	0–2 vol-%: <b>±0.1 vol-%CH<sub>4</sub> / year</b> 2–5 vol-%: <b>±5% of reading / year</b>	±2 vol-%/year
Start-up time <sup>3)</sup>		30 s
Warm-up time <sup>4)</sup>		2 min <sup>5)</sup>
Response time (T <sub>90</sub> )		90 s <sup>6)</sup>
Response time with flow-through adapter		90 s at ≥ 0.5 l/min <sup>6)</sup> (recommended: 0.5–1 l/min)

1) Excluding cross-references to other gases.

2) Accuracy specification at 25 °C (+77 °F) and 1013 hPa including non-linearity, calibration uncertainty, and repeatability; temperature and pressure compensated.

3) Time to first reading.

4) Time to specified accuracy.

5) At +20 °C (+68 °F) ambient temperature.

6) With standard PTFE filter.

## Operating environment

Operating temperature range	-40 ... +60 °C (-40 ... +140 °F)
Operating humidity range	0–100 %RH
Storage temperature range	-40 ... +60 °C (-40 ... +140 °F)
Storage humidity range	0–90 %RH
Process pressure range	-500 ... +500 hPa
Process temperature range	+0 ... +60 °C (+32 ... +140 °F)
Process flow range	0–20 m/s

## Compliance

Electromagnetic compatibility (EMC)	EN 61326-1, industrial environment
Compliance marks	CE, China RoHS, RCM
Ex approval marks	EU (ATEX), international (IECEx), US/CAN (cMETus), Japan (CML), UK (UKEX), Korea (KCs) <sup>1)</sup>
Ex classification	Ex II 1/2 (I) G Ex eb mb [ia] IIB T3 Ga/Gb -40 °C ≤ Tamb ≤ +60 °C Class I, Division 2, Groups C, D; T3

1) See product documentation for full Ex classifications for each region.

## Inputs and outputs

Operating voltage	18–30 V DC
Power consumption	Typical: 3 W Maximum: 6 W
Digital output	RS-485 (Modbus RTU)
Analog output	3 × 4–20 mA scalable, isolated
Analog output load	Minimum: 0 Ω Maximum: 500 Ω
Analog output accuracy	±0.2 % of full scale at 25 °C (77 °F)
Analog output temperature dependence	0.005 %/°C (0.003 %/°F) full scale
Analog input (recommended)	1 × 4–20 mA (Ex ia) for external pressure or temperature sensor <sup>1)</sup>

1) The optional analog input is galvanically isolated and provides power for the connected external pressure sensor.

## Mechanical specification

Weight	3 kg (6.6 lb)
Thread type	1.5" male NPT
Mechanical pressure tolerance	20 bar(g)
Cable lead-throughs	1 × M16x1.5 2 × M20x1.5
IP rating	IP66
<b>Materials</b>	
Probe body	AlSi316L stainless steel, PPS
Filter cap	Sintered PTFE

## Options and accessories

Configuration cable (RS485/USB) <sup>1)</sup>	257295
Flow-through adapter	258877
Sintered PTFE filter (includes O-ring)	DRW249919SP
MGP260 Series Ex e connector set	265897
NPT 1.5" thread test plug	257525SP

1) Vaisala Insight software for Windows® available at [www.vaisala.com/insight](http://www.vaisala.com/insight).

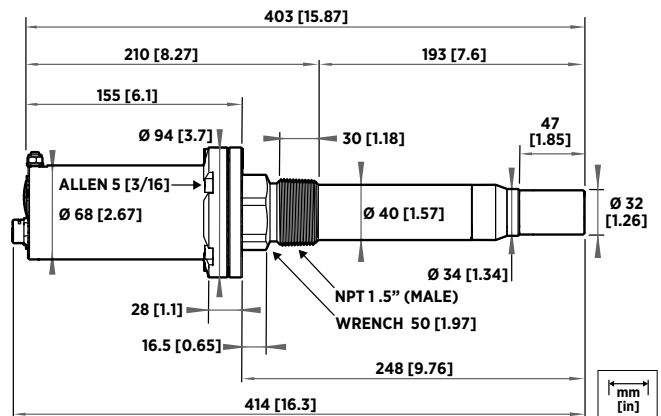

MGP262 dimensions