

### FEATURES OF BATTERY

- Function : Bluetooth + BMS Protection+Alarm system(optional)+IP65
- High Power : It can support 105 A continuous discharge, 300A(35s)
- Warranty: 5 years Warranty
- Custom : Print logo and customized colors
- Certificates: MSDS,UN38.3 and CE
- Available models : 36V/ 48V/ 72V/ 105Ah 150Ah 180Ah 210Ah
- Warehouse: Fast delivery within 7 days



### SPECS OF BATTERY AND BMS

ELECTRICAL SPECIFICATIONS		MECHANICAL SPECIFICATIONS	
Nominal Voltage	73.6V	Terminal Type	2*M8 Bolts
Nominal Capacity	105Ah	Weight	63kg
Nominal Energy	7.728kWh	Case Dimension(L*W*H )	558×333×285(mm) ±2mm
Combination type	24S1P	Shipment of products with electricity	50%-70% Current delivery
Charging voltage	83.95V	Cell type / Chemistry	LiFePO4 EVE Grade A cell
Rated capacity	210Ah	LCD or Bluetooth Functio	Both available
Internal resistance	≤60mΩ	Package material	Carton box or pallet
Maximum In Parallel	Optional	BMS:low voltage,high voltage,over temperature,Over current. short-circuit protection .etc	
Discharge Current and Voltage Specifications		Charge Current and Voltage Specifications	
MAX Continuous Discharge Current	105A	Maximum charge duration current	250A
Peak Current	300A ( 35S)	Recommended Charge Current	18A
Discharge cutoff voltage	66V	Recommend Charge voltage	82.6V-83.9V
Short Circuit Protection	Yes	Balancing Voltage	53V
Safety Specification		COMPLIANCE SPECIFICATIONS	
Short-circuit protection	Yes	Discharge Temperature	-20 ~ +55°C
Low / High Temperature discharging	Yes	Charge Temperature	0 ~ +45°C
Low / High Temperature charging	Yes	Storage Temperature Range	-20 ~ +45°C
Over-current discharging	Yes		
Over-current discharging	Yes		
Certificates	IEC62133 UL2580 (Cell) UN38.3,MSDS,CE for pack		

# SUPER CUSTOM VIP

SC72105 73.6V 105Ah

## Battery Connection Diagram

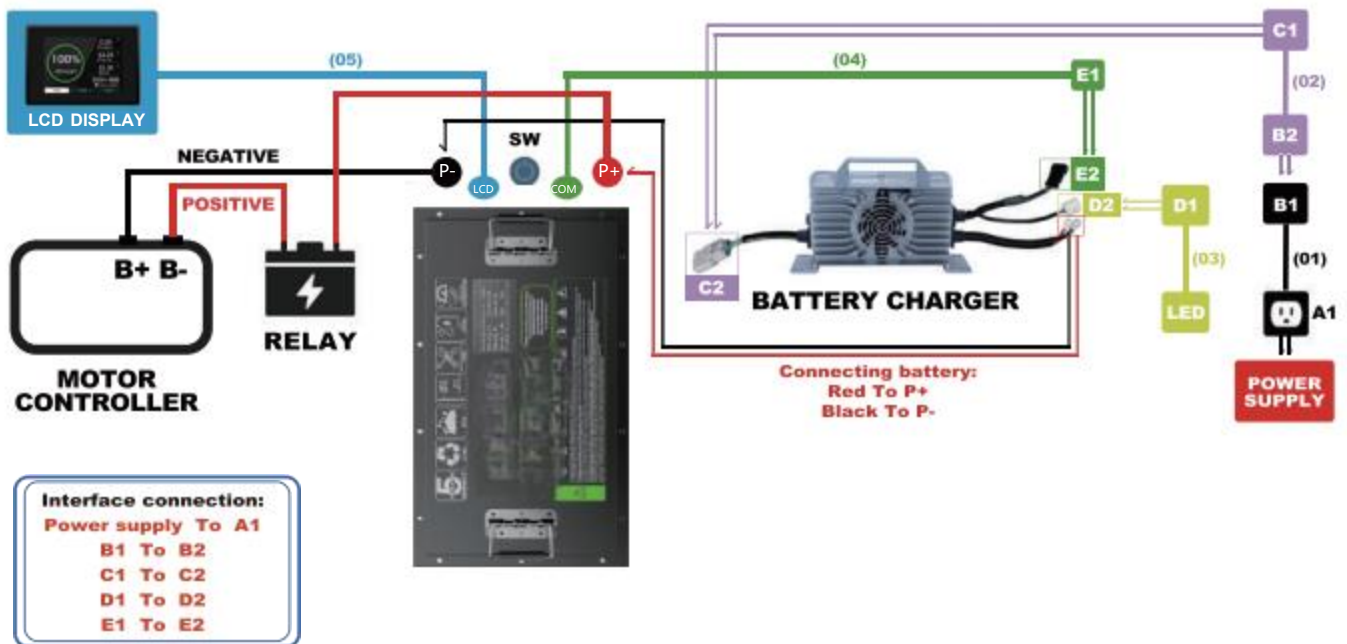

**BATTERY PARK**

**BOLT**

**CHARGER**

**CONVERTER**

**CONTROLLER**

Prior to connecting the metal terminals on the harness with screws, it is necessary to ensure that the corresponding connectors are properly aligned. Once this is done, the screws should be tightened. It is important to note that the larger the cable, the closer to the end of the screws it should be. Conversely, the smaller the cable, the closer to the nut it should be.

