

Human exposure assessment solutions for electromagnetic fields in automotive environment

APPLICATION NOTE



AN_EAE_EN_V1.1

Index

1. INTRODUCTION.....	4
2. LOW FREQUENCY FIELD EFFECTS	5
3. MEASUREMENT CONDITIONS AND LOCATION	6
3.1 Conditions and procedure	6
3.2 Measurement locations.....	7
3.2.1 Seat measurement	7
3.2.2 Electric and electronic components/module measurements.....	8
4. MEASUREMENT TECHNIQUES.....	8
4.1 Measurement methods (DC, AC Time domain evaluation and FFT).....	8
4.1.1 AC Time domain evaluation	8
4.1.2 AC Frequency domain measurements (FFT Analysis) 9	
4.1.3 DC (static) Magnetic field measurement.....	9
4.1.4 High Frequency E field measurements.....	9
4.2 Measurement instrument	10
5. AUTOMOTIVE STANDARDS AND THEIR REQUIREMENTS.....	11
5.1 GB/T 37130 and GB 8702-2014 standard.....	12
6. SMP3-STREAMER OPTION	13
7. HOW TO MEASURE USING WAVECONTROL SOLUTIONS.....	15
7.1 Measurement using the SMP3 as a standalone solution....	15
7.2 Measurement using the Streamer option	15
References	18

WAVECONTROL

Application Note
**Human exposure
assessment
solutions for
electromagnetic
fields in automotive
environment**

1. INTRODUCTION

Drivers and passengers of automotive vehicles are exposed to significant low-frequency magnetic fields due to higher currents emitted by different electrical and electronic components in these vehicles. With a higher demand for electric cars to minimize pollution and enforce decarbonization, there is an increased low frequency electromagnetic fields (EMF) risk which must be assessed to ensure that the vehicle users are safe from overexposure to EMF.

As required by law, international organizations and car manufacturers have developed standards to check that automotive vehicles comply with national and international EMC safety regulations. This assessment must be done from DC to 400

kHz as this is the frequency range applicable to any type of electrical equipment, engine or internal energy source found in commercial vehicles.

In this application note, the new requirements from the automotive industry will be reviewed and the most complete solution to comply with these strict EMF assessment requirements will be presented which is the new SMP3 portable EMF meter and the SMP3-Streamer Option from Wavecontrol. The SMP3 meter complies with the IEC 61786-1 and IEC 62311 standards which set the measuring instrument fundamental requirements for all the automotive standards used to prepare the application note.

General assessment methods are described in accordance with the following standards and many more:

- IEC 62764:2022 – '*Measurement procedures of magnetic field levels generated by electronic and electrical equipment in the automotive environment with respect to human exposure - Part 1: Low frequency magnetic fields*'.
- JASO TP-13002: 2013 – '*Measurement methods for electromagnetic field of vehicles with regards to human exposure*'.
- GB/T 37130: 2018 – '*Measurement Methods for Electromagnetic Fields of Vehicle with regard to Human Exposure*'.

The standards from Automotive vehicle and components manufacturers such as PSA, Mercedes, Volvo, Ford, Volkswagen, General Motors, Jaguar/Land Rover and many others were also taken into account.

2. Low Frequency field effects

Exposure to low frequency fields cause well-defined biological responses such as direct stimulation of the nerve and muscle tissues, induction of the retinal phosphenes and other indirect effects. These effects are known as electrostimulation or non-thermal effects and are categorized within the frequency range of 1 Hz to 10 MHz. Normatives define exposure limits for this type of effects within this range.

In automotive sector, this is the relevant effect that needs to be assessed for users of vehicles. Additionally, some manufacturers require assessment of DC magnetic fields to account for bearers of active implanted medical devices to avoid any interference due to significant static H fields.

Some important standards for these effects include ICNIRP 1998 and 2010, IEEE C95-1, EU directives, GB 8702-2014 and many other.

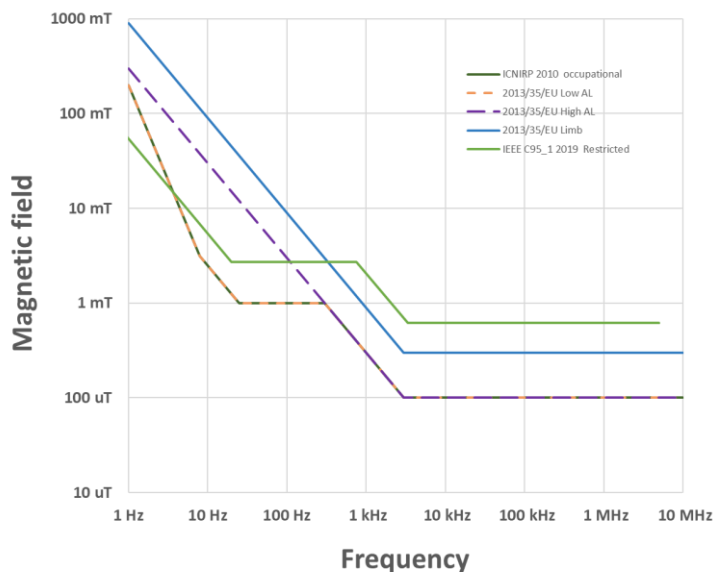

Figure 1. Low frequency Magnetic field limits

3. Measurement conditions and location

3.1 Conditions and procedure:

Each standard specifies the measurement conditions for assessing vehicles. However, generally measurements should cover only the sources of persistent magnetic field exposure mainly from the device under test (i.e., the vehicle) and not external sources in the measurement site. The ambient magnetic field should be measured without the vehicle under similar conditions as the vehicle.

Hence, it is not mandatory to test in a shielded exposure, however, it is important to ensure that no magnetic field sources within the vicinity of the vehicle being measured is significantly affecting the measurement result.

Measurements must be performed in all standard operational modes of the vehicle, which are:

Stationary mode, **Driving** mode, **Dynamic mode** (including acceleration and deceleration as sub-modes) and **Plug-in charging** mode.

In driving mode, a vehicle speed of 40 ± 8 km/h is recommended when performing tests. During this mode test, all electric load conditions must be recorded. A dynamometer (or roller bench) may be used if it rotates all the wheels of the vehicle to simulate the outdoor dynamics of the vehicle in both driving and dynamic modes tests.

Typically, acceleration should be performed from 0 km/h to 90 km/h or the maximum possible by the vehicle, achieving at least 2.5 m/s^2 between 10 km/h and 75 km/h and vice versa for deceleration.

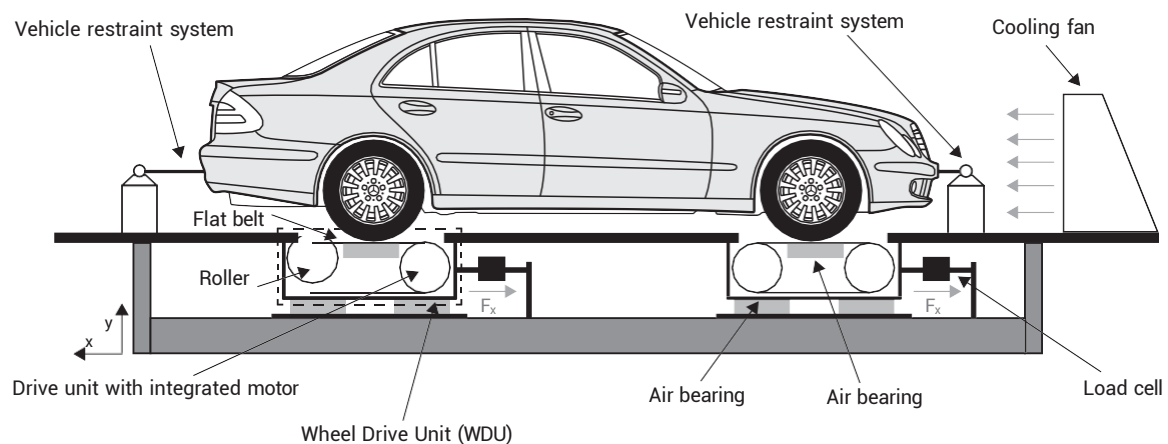

Figure 2. Picture of vehicle on a dynamometer during testing

3.2 Measurement locations

All parts of the vehicle accessible by either the driver or passengers (including bystanders within proximity) must be measured. These include locations inside and outside the vehicle,

for example, the cabin area for both driver and passenger, the storage area, central control, engine, electrical and electronic components, charging ports, and the car seats.

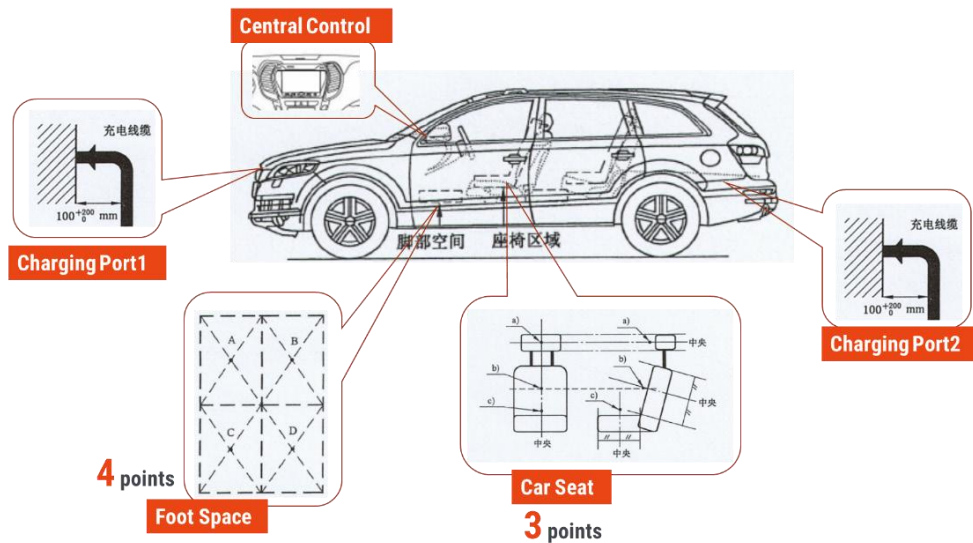

Figure 3. Electric vehicle test points

3.2.1 Seat measurement

For each individual seats, assessment has to be done at the head, trunk and the legs (including the feet) as seen in the figure 4. Multiple simultaneous measurements can be taken to cover these areas, thereby speeding up the test process.

Measurements must also be performed around the outside of the vehicle in all areas accessible to parts of the human body identified in the applicable manufacturers' requirements.

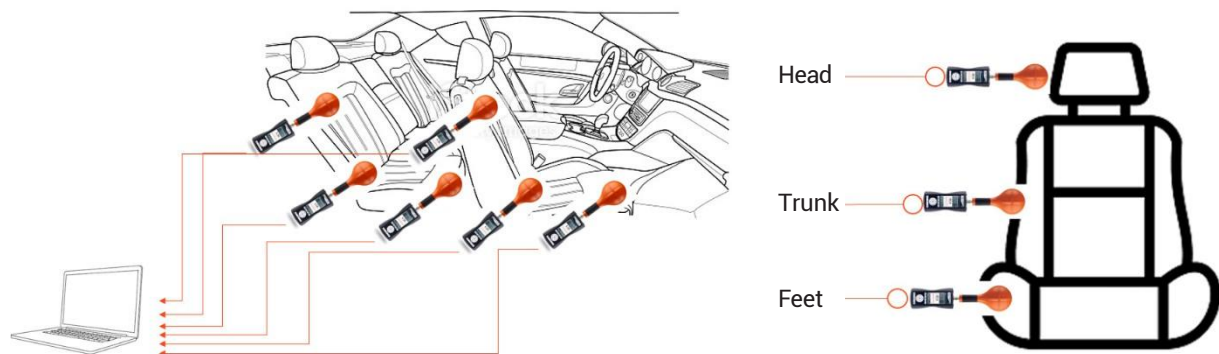

Figure 4. Seat points to be measured (Head, Trunk and Leg)

3.2.2 Electric and electronic components/ module measurements

All components that are part of the vehicle which generate magnetic field must be measured. These components contribute to the persistent sources of H field. However, some modules which are transient H field sources should also be assessed.

For testing these components and modules, most EMC standards from manufacturers define the test setup, equipment requirement, measurement test point, distances and procedures to follow. Here is an example of the test setup from the PSA standard (Figure 5) where measurements of these components are done at a distance of 5 cm in passenger compartment or trunk and 30 cm in the engine compartment.

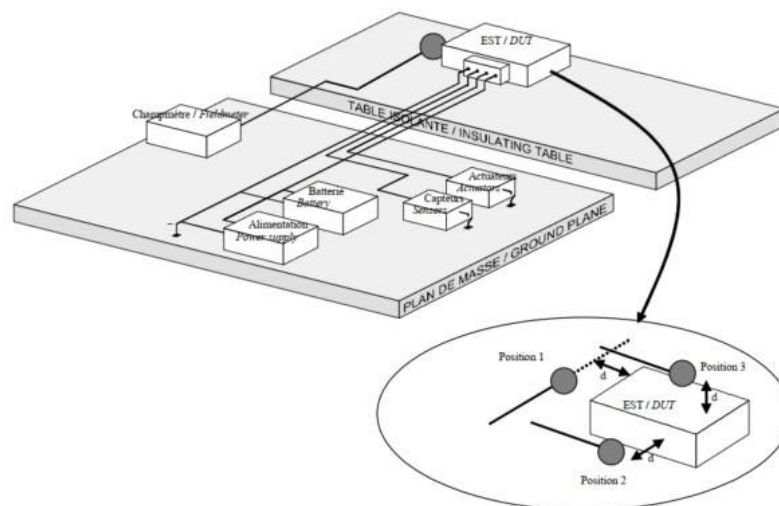

Figure 5. Test setup example for electrical components of a vehicle (source: PSA standard)

4. Measurement Techniques

4.1 Measurement methods (DC, AC Time domain evaluation and FFT)

In automotive application, magnetic field is the most dominant field that must be assessed due to higher currents generated from different sources. However, some automotive standards may require assessment of electric field also. Measurements are carried out mainly between 1 Hz to 400 kHz covering electrostimulation effects using the WP400 probe. The two measurement methods for AC fields as required by these standards are the time domain and frequency domain evaluation methods.

4.1.1 AC Time domain evaluation

The SMP3 uses the Weighted Peak Method (WPM), which is the required method for time domain LF exposure assessment. It consists of an evaluation of the signal in the temporal domain, implemented in the device with digital signal processing to perform a spectral weighting and an assessment with respect to a reference standard limit curve. Hence, the results are given as a direct weighted percentage of the standard (Figure 6).

4.1.2 AC Frequency domain measurements (FFT Analysis)

Standards require doing an FFT analysis of the H field. In the SMP3 when using a selective probe, FFT analysis can be achieved by selecting this option on the dynamic menu MODE. The device computes the FFT of the signal, thus providing a spectrum (frequency domain) view of the signal.

In the automotive sector, standards like the GB/T 37130 require special frequency resolution steps which the SMP3 may not fulfil as a standalone solution, hence, the Streamer option will be required for such application.

Other methods defined in some standards are Static (DC) magnetic field and high frequency electric field measurements.

4.1.3 DC (static) Magnetic field measurement

Vehicle users include everyone from the general population, therefore one additional requirement by some standards could be static H field measurement to comply with the AIMD limit of 500 μ T to prevent interference with these medical devices worn or implanted in the user. Evaluation of static magnetic field must be done to obtain the resultant H-field with an isotropic (tri-axial) probe, as the summation of the three components of the field. The WPH-DC probe is required for this type of measurement.

4.1.4 High Frequency E field measurements:

Broadband E field measurements using an isotropic probe could be a requirement due to the presence of portable transmission devices as part of the vehicle components. Additional E field broadband RF probes will be needed for this type of measurement.

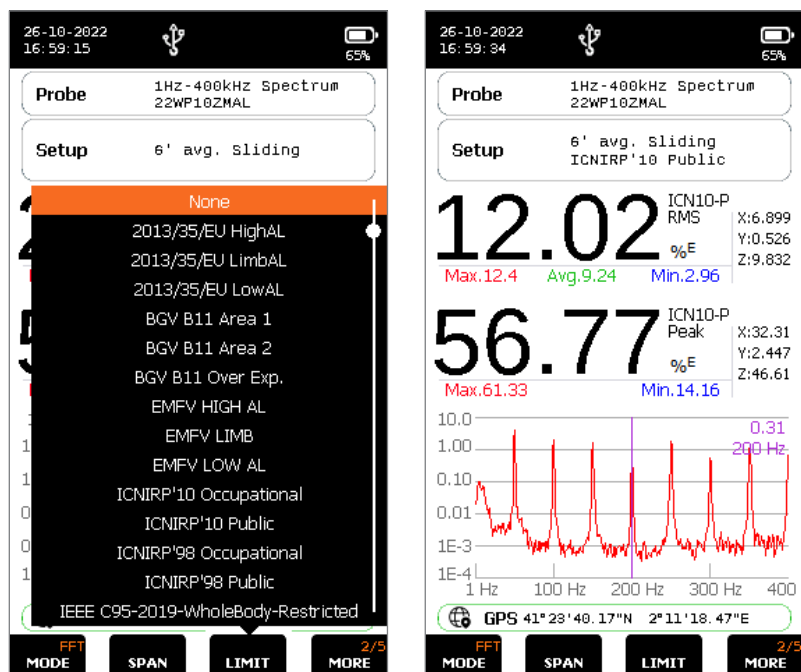

Figure 6. SMP3 screen with %ICNIRP value WPM

4.2 Measurement instrument

Measurement instrument requirements depends on the standard being followed. However, the equipment must meet some fundamental requirements, such as:

- The device must comply with IEC 61786-1 and IEC 62311 standards.
- The probe used must have a sensor area of $100 \pm 5 \text{ cm}^2$.
- The device must cover a frequency range of 1 Hz to 400 kHz (some standards start from 10 Hz).
- The device must allow for the Weighted Peak Method and FFT analysis up to 400 kHz.
- All relevant limits must be embedded in the measurement instrument.

The SMP3 + WP400 series probes meet these requirements as a standalone solution. Some standards may require additional frequency tests such as static H field or radiofrequency E fields up to 6 GHz. In such case, the WPH-DC or WPF6 or WPF8 probe must be used.

Other standards may impose additional FFT requirements between 1 Hz to 400 kHz that require a frequency resolution as low as 1 Hz, which the solution is the SMP3 + WP400 probe + Wavecontrol SMP3-Streamer Option Software (see Section 6).

Note: WP400 series probes refer to the WP400, WP400c or the WP10M probe (using a 400 kHz BW).



Figure 7. SMP3 and its relevant probes for automotive industry (WPH-DC, WP400, WPF6/8/18)

5. Automotive standards and their requirements

There are different standards from different automotive manufacturers or organizations (national or international) which require specific or a combination of tests. These standards include **IEC 62764-1** (International), **GB/T 37130** (China), **JASO TP-13002** (Japan) and other manufacturer standards such as **B217110 PSA-MR02**, **GMW 3091**, **FMC 1278**, **TL 81000**, **STD 515-0003**, **MBN 10284-2**, **TSC7048G** and many more.

Table 1 summarizes the different test requirements (A-E) and the types of tests needed. Test requirements for A – C can be met with a standalone solution of the SMP3 and probes, whereas D and E require the SMP3-Streamer option.

Table 1: Automotive standards and their different test requirements.

Required measurements	Automotive standard requirements				
	A	B	C	D	E
DC H-field					✓
LF H-field Time domain From 1 Hz or 10 Hz– 400 kHz	✓	✓	✓	✓	✓
LF H-field Frequency domain From 1 Hz or 10 Hz – 400 kHz		✓		✓	✓
E field Time domain Up to 6 GHz.			✓		

Table 2: Test requirements, Wavecontrol solutions and examples of standards.

Requirements	Wavecontrol Solution	Standards – Examples
A	SMP3 + WP400	IEC 62764-1, FMC 1278, TL 81000, STD 515-0003
B	Same as A	GMW 3091
C	SMP3 + WP400 + WPF6	PSA MR02 B217110.
D (reduced freq. step)	SMP3 + WP400 + SMP3-Streamer option	GB/T 37130, JLR-EMC, TSC7048G
E (reduced freq. step)	SMP3 + WP400 + WPH-DC + SMP3-Streamer option	MBN 10284-2

5.1 GB/T 37130 and GB 8702-2014 standard.

The GB/T 37130 standard provides measurement procedures for low frequency magnetic field human exposure from 10 Hz to 400 kHz in automotive environment. Assessment has to be done to comply with the GB 8702 (2014) and ICNIRP 98/2010 exposure standards for general public. The measuring instrument must comply with the specification stated in section. The GB/T standard sets some strict requirements for using the measurement instrument, which are as follows:

- Field measurement in both time and frequency domain.
- In time domain evaluation, measurement must be carried out with the weighted results given with respect to the ICNIRP 98 general public reference levels.
- In the frequency domain (FFT) measurement, the fields between 10 Hz to 400 kHz must not exceed the exposure limits for the GB 8702-2014. Additionally, the standard also sets minimum requirements for the frequency resolution in the FFT assessment:

Hence, 1 Hz frequency resolution is required for performing such assessment which the SMP3 + WP400 probe cannot fulfil as a standalone solution. The standard also describes the measurement locations (similarly described in Section 3) which require performing multiple points measurements. Therefore, a solution that can meet the many requirements, such as simultaneous time and frequency domain measurements, 1 Hz frequency resolution and multiple device measurements at the same time, will be required to meet the GB/T 37130 standard. The most complete and cost-effective solution in the market is the SMP3 + WP400 + SMP3-Streamer option.

Table 3: Minimum frequency resolution requirements defined by the GB/T 37130 (similar condition applies in MBN 10284-2 and TSC7048G)

Frequency range	Frequency resolution
10 Hz ≤ f < 5 kHz	≤ 1 Hz
5 kHz ≤ f < 50 kHz	≤ 5 Hz
50 kHz ≤ f ≤ 400 kHz	≤ 50 Hz

6. SMP3-Streamer option

The SMP3-Streamer option includes a software, called the Wavecontrol Streamer, which is compatible with the SMP3 device and WP400 probe designed to comply with the advanced testing requirements of the automotive standard, particularly the GB/T 37130. It uses the USB-3 of the SMP3 to perform real-time FFT analysis for magnetic fields up to 400 kHz. The SMP3-Streamer Option includes a software that allows for:

- Magnetic field measurement (1 Hz- 400kHz)
- Simultaneous measurements for both time and frequency domain.
- The user to select independent limits for both Time and Frequency domain.
- Achieving a frequency resolution of 1 Hz in the entire band 1 Hz to 400 kHz.
- Doing real time FFT measurements with the results stored without the need of an external acquisition card.
- Multiple systems (SMP3 + WP400 probes) simultaneous measurement (up to 7 devices).
- Exporting the data to an Excel report with 2 sections (results for Time domain and for Frequency domain).
- The max and minimum fields for all frequencies are saved in the report.
- Visualization of both Frequency and Time domain measurement graphs.

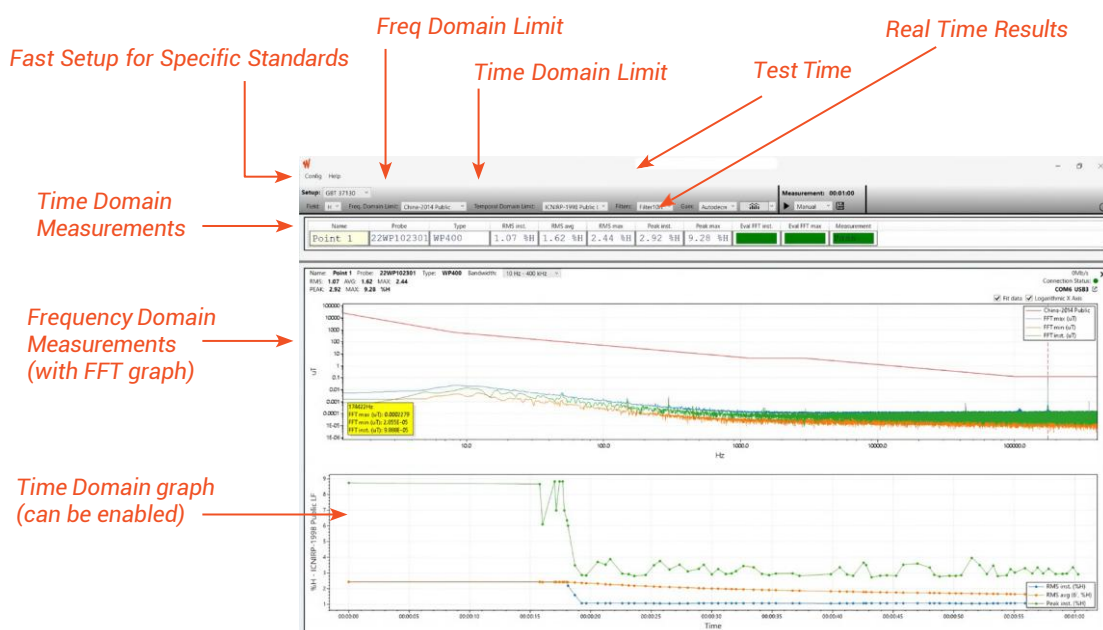

Figure 8: Wavecontrol SMP3-Streamer Option Software

On the software screen, the user can select the Fast setup for specific standard or set the parameter according to their preferred settings for both time and frequency domain. The first line is for the measurement configurations, and the subsequent lines represent the time domain measurements. The final section is for the

graphs, specifically for the frequency domain measurement. The time domain graphs can also be enabled.

For every new device connected a new line and graph is added in the display as seen in the figure below. Here is a sample of measurement with the Streamer from 2 SMP3 devices at the same time:

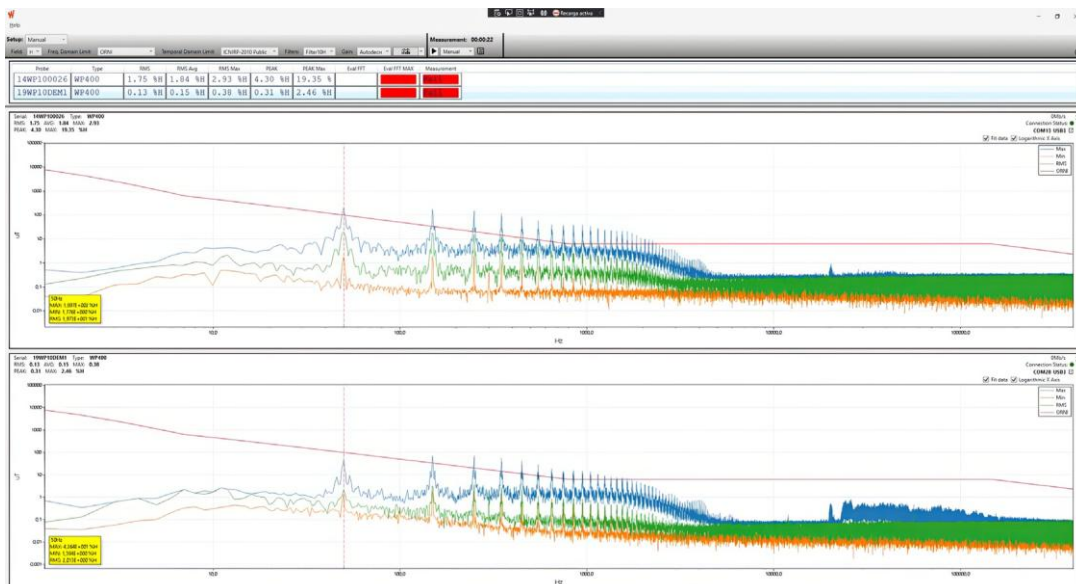

Figure 9: Multiple simultaneous SMP3 measurements (2 devices)

When no limit is selected, the time domain values are in μT and no limit line appears on the frequency domain graph. The time domain results are in % of the standard limits and the limit curve of the selected standard is displayed on the graph. Following the GB standard requirements if the field at any frequency exceeds the limit curve, the test is a FAIL, and this is displayed on the software screen and in the Excel report in red.

7. How to measure using Wavecontrol solutions.

The device can be used as a standalone solution or with the Streamer option depending on the requirements stated in section 5.

7.1 Measurement using the SMP3 as a standalone solution.

As a standalone solution, the SMP3 and its probe can be used for static H field measurements (WPH-DC), low frequency E/H field measurements up to 400 kHz (WP400) or high frequency E field up to 6 GHz (WPF6 or WPF8 or WPF18). To carry out measurement, these easy steps must be followed:

- Turn on the SMP3 device, connect the probe and configure the measurement parameters:
 - Test parameters (sampling, measurement time, averaging time and type (only for high frequency field))
 - On the virtual menu, select the Field type: E or H.
 - MODE: Time or FFT (Frequency)
 - Select a Limit (predominantly, ICNIRP 98).

- Place the measuring instrument in the measurement spots specified in the standards and follow the correct procedures (see Section 3).
- Press the LOG button to save measurements.
- Open the SMP software on a PC and connect the meter.
- Export the measurement data as an Excel report.

7.2 Measurement using the Streamer option.

The Streamer option is required if much smaller frequency steps are defined by the standard and the SMP3 cannot meet as a standalone solution. Also, to achieve simultaneous time and frequency domain measurements and multiple system measurements, the SMP3 + WP400 + Streamer option will be the right solution for 1 Hz to 400 kHz bandwidth.

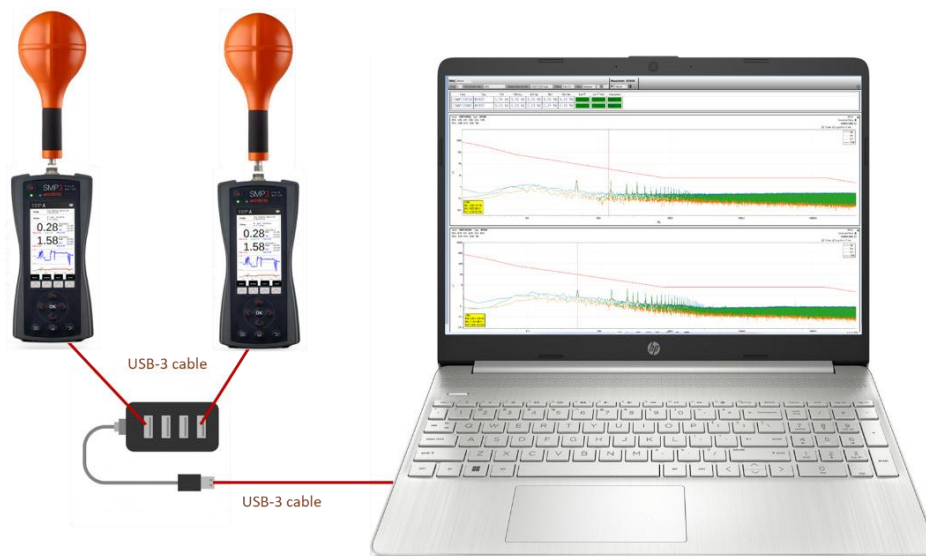
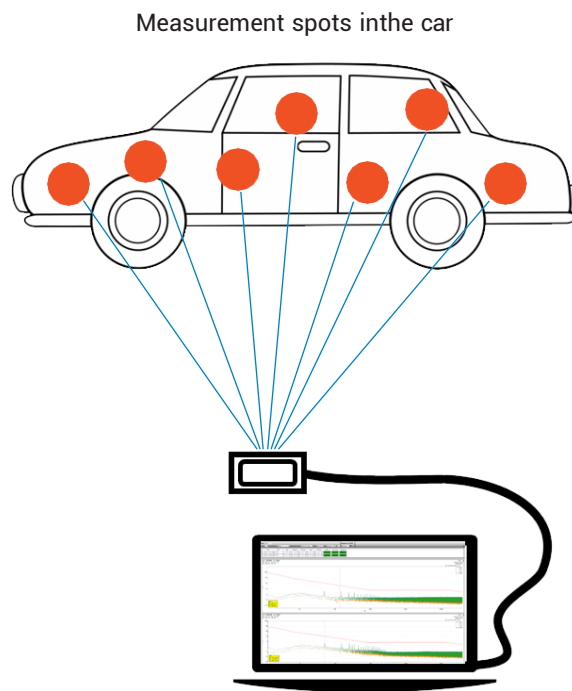

Figure 10: Measuring 2 simultaneous points using the SMP3-Streamer Option software.

To perform measurement using the Streamer option, follow these steps below:

- Open the Streamer software.
- Switch on and connect Streamer-licensed SMP3 devices (up to 7 devices).



- Setup the test parameters (Limits for both time and frequency domain and filter) or select the Standard in the Setup drop-down menu to have these settings pre-defined. Also, set the measurement time.

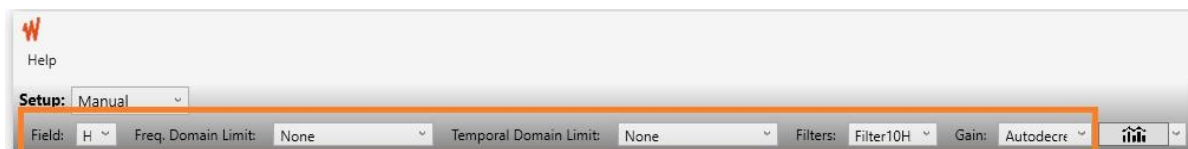

- Start the measurement by clicking the Play button ▶. During measurements you can analyse the FFT graph using the mouse cursor.

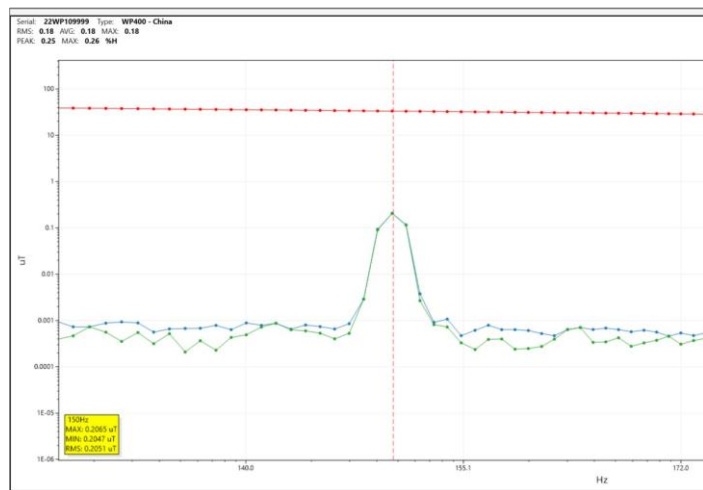
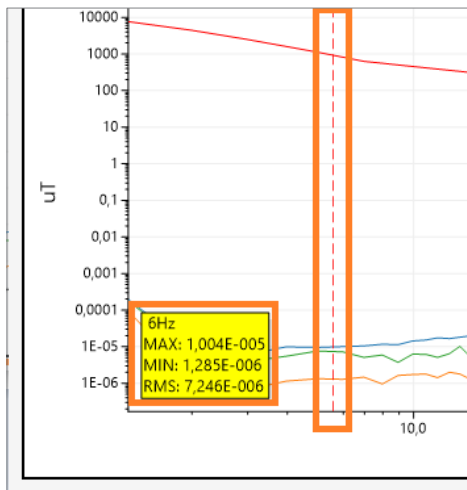

- The software will indicate if it is a PASS or FAIL.



PASS



FAIL

- Export the measurement data to Excel format by clicking the Save button .

References

- [1] IEC 62764:2022 Measurement procedures of magnetic field levels generated by electronic and electrical equipment in the automotive environment with respect to human exposure - Part 1: Low frequency magnetic fields. International TC 106, September 15, 2022..
- [2] GB/T 37130-2018 Measurement Methods for Electromagnetic Fields of Vehicle with regard to Human Exposure. National Standard of the People's Republic of China (GB), December 28, 2018..
- [3] JASO TP-13002-2013 Measurement methods for electromagnetic field of vehicles with regards to human exposure. Japan Society of Automotive Engineers (JSAE), 2013 Edition, March 1, 2013.
- [4] IEC 61786-1:2013 Measurement of DC magnetic, AC magnetic and AC electric fields from 1 Hz to 100 kHz with regard to exposure of human beings – Part 1: Requirements for measuring instruments.
- [5] IEC 62311:2019 Assessment of electronic and electrical equipment related to human exposure restrictions for electromagnetic fields (0 Hz to 300 GHz).
- [6] ICNIRP 1998 Guidelines for limiting exposure to time varying Electric, Magnetic and Electromagnetic fields (up to 300 GHz), HEALTH PHYSICS 74(4):494-522; 1998.
- [7] ICNIRP 2010 Guidelines for limiting exposure to time varying Electric and Magnetic fields (1 Hz – 100 kHz), HEALTH PHYSICS 99(6):818-836; 2010
- [8] GB 8702-2014 Controlling limits for electromagnetic environment. National Standard of the People's Republic of China (GB), September 23, 2014.
- [9] IEEE C95-1 2019 IEEE Standard for Safety Levels with Respect to Human Exposure to Electric, Magnetic, and Electromagnetic Fields, 0 Hz to 300 GHz.

WAVECONTROL
Safety, Quality, Service

+34 93 320 80 55
www.wavecontrol.com
info@wavecontrol.com