

Instruções de montagem

Suporte para halteres

HZ-0004

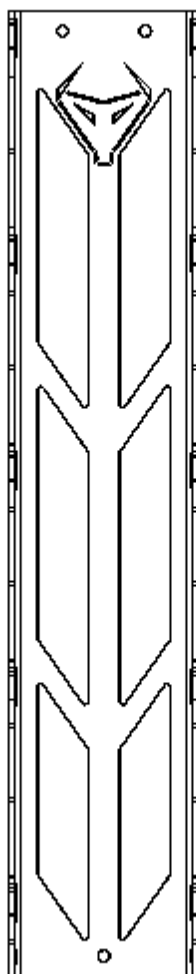

Obrigado por adquirir o suporte para halteres **HORIZONTE by Lezoconcept**. Este produto foi concebido para otimizar o seu espaço e organizar os seus halteres de forma segura e elegante.

Incluído na caixa:

- Suporte para halteres
- 3 parafusos M5 x 40
- 3 buchas diâmetro 8 mm

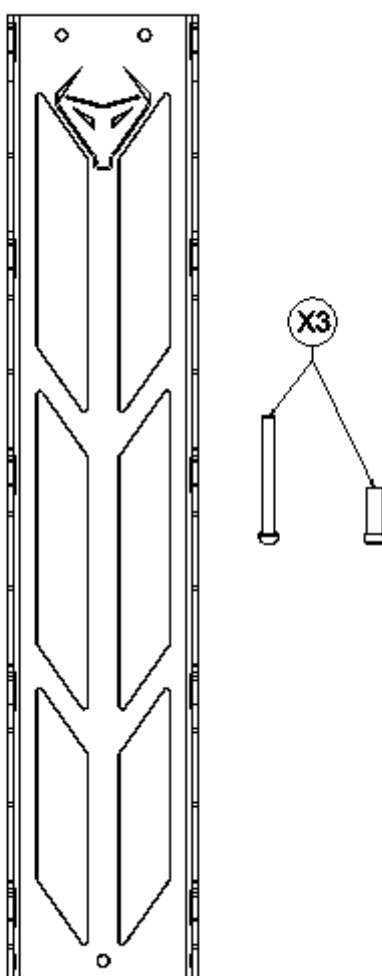

Ferramentas necessárias:

- Berbequim elétrico
- Broca de 8 mm
- Nível de bolha
- Chave de parafusos Phillips

Instruções

1. **Seleção da superfície:** Escolha uma parede sólida e resistente para instalar o suporte com segurança.
2. **Cálculo da altura:** Meça a altura desejada a partir do chão.

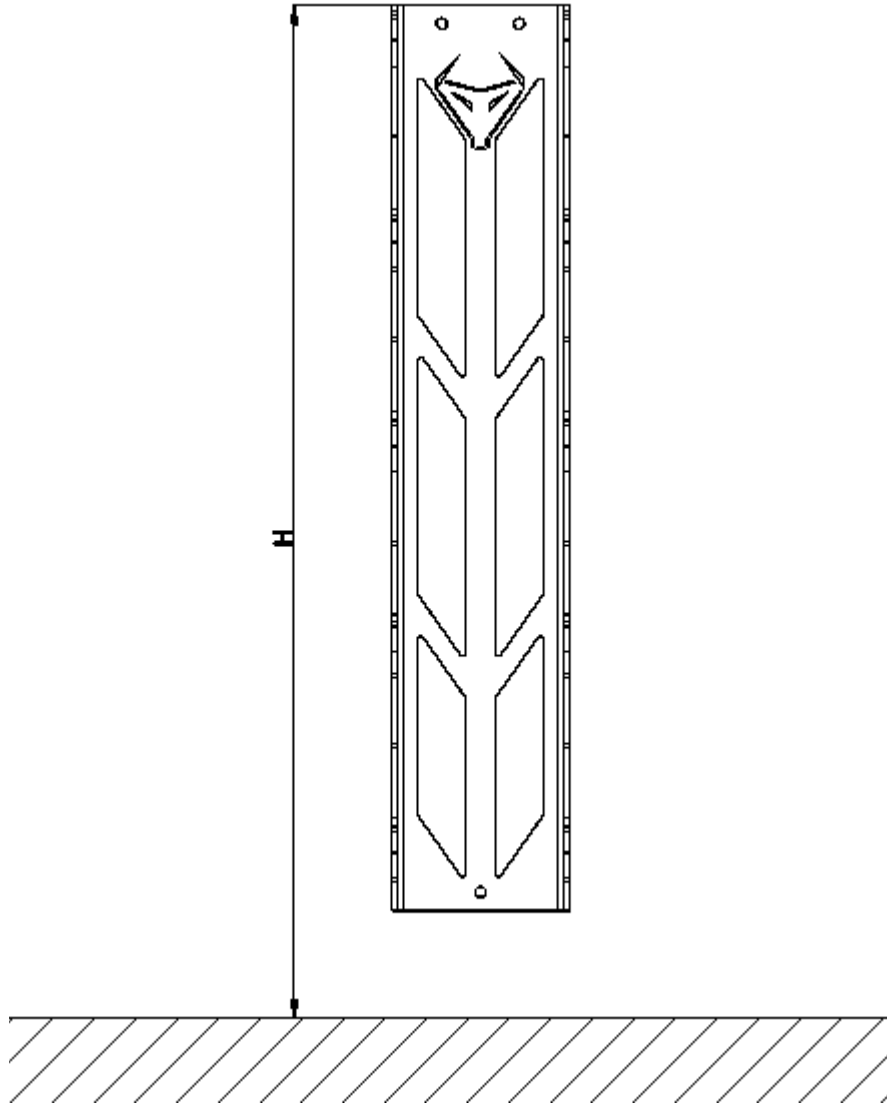

3. **Marcação e perfuração:** Coloque o suporte contra a parede, nivele-o com o nível de bolha e marque os 3 pontos de fixação com lápis. Faça os furos com a broca de 8 mm.

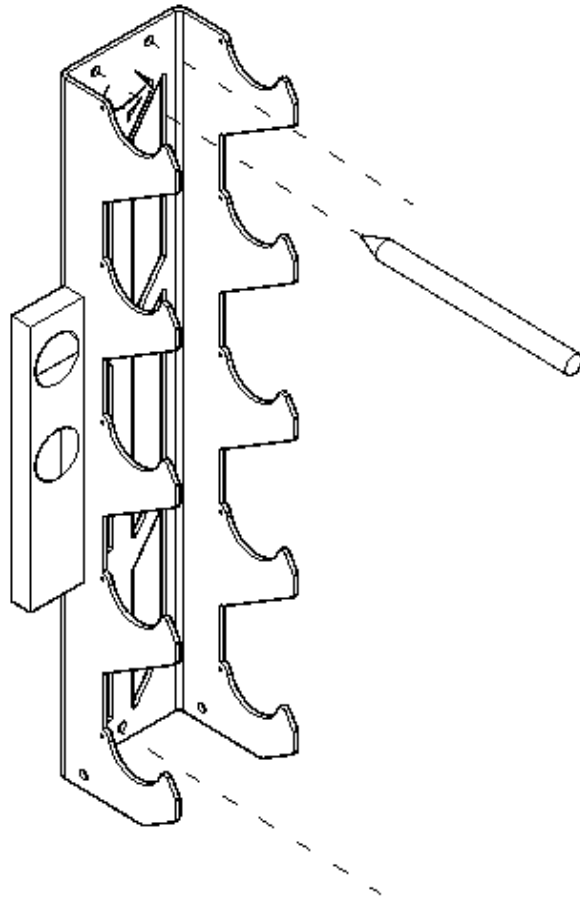

4. **Marcação e perfuração:** Coloque o suporte contra a parede, nivele-o com o nível de bolha e marque os 3 pontos de fixação com lápis. Faça os furos com a broca de 8 mm.

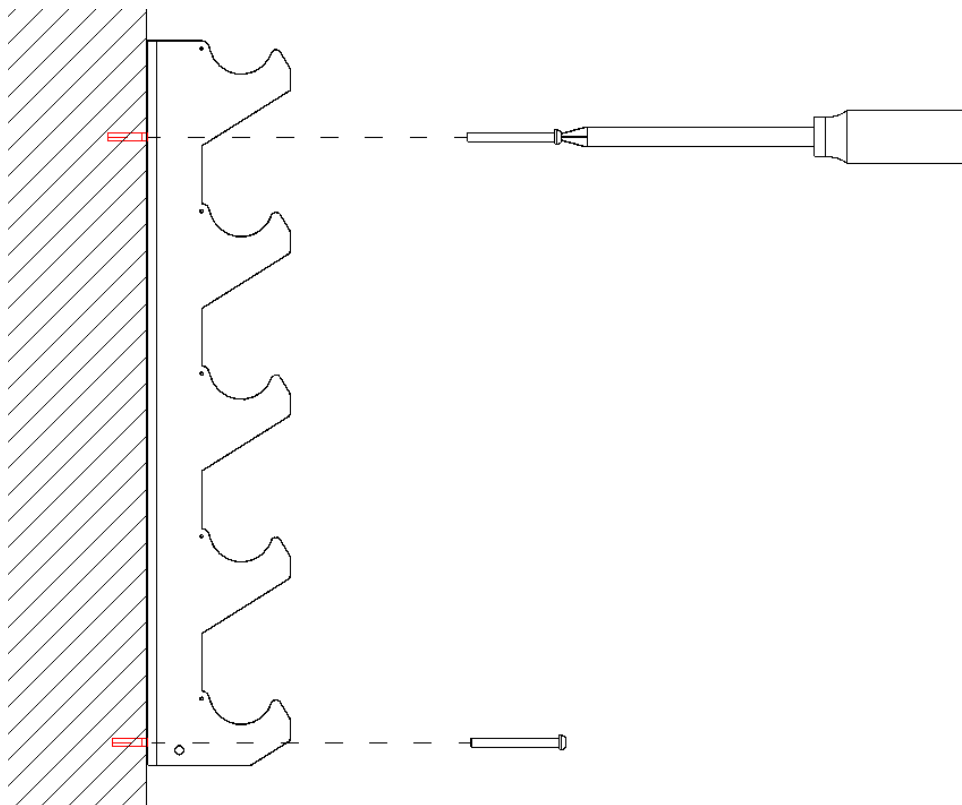

O seu suporte para halteres **HORIZONTE** está pronto a utilizar.

Safety Information / Warnings

1. **Maximum Load:** Do not use the wall brackets to support a total combined weight exceeding 100 kg. Exceeding this limit may cause wall damage or personal injury.
2. **Mounting Location:** Install the product only on sturdy, solid walls (concrete, solid brick, or structural timber). Do not mount on drywall (Pladur/gypsum board), light partitions, or hollow surfaces, as they could deform or break under the weight.
3. **Adult Assembly:** Installation must be performed exclusively by adults with the appropriate tools. Not suitable for installation by children.
4. **Periodic Inspection:** Regularly check (once a month) that the screws and wall plugs remain tightly secured. Tighten any loose screws immediately to prevent accidents.
5. **Correct Use:** Use the rack exclusively for hanging dumbbells. Do not climb, hang, or apply body weight or other heavy objects to the structure.
6. **Keep Away from Children and Pets:** Keep children and animals away during assembly and daily use.
7. **Disclaimer:** The manufacturer is not responsible for any material or personal damage resulting from incorrect installation, overloading, or improper use of the product.

Pictograms



W001

General warning - Read the safety instructions before use.



P010

Maximum load: 100 kg. Do not overload.



W001 + 

Fix only to solid walls - Do not install on drywall or hollow bricks.



P001

Adults only - Assembly must be performed by adults .



P013

Do not climb - Risk of detachment if hanging from the structure. .



M001

Wear protective gloves during installation.