

# Montage-instructies

Dumbbellhouder

HZ-0004

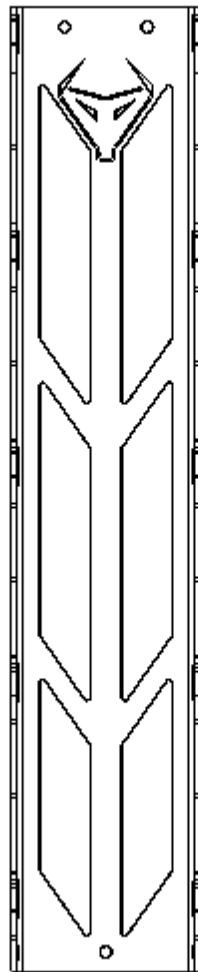

Bedankt voor de aankoop van de dumbbellhouder HORIZONTE by Lezoconcept. Dit product is ontworpen om uw ruimte te optimaliseren en uw dumbbells veilig en stijlvol te organiseren.

### Inhoud van de doos:

- **Dumbbellhouder**
- **3 schroeven M5 x 40**
- **3 pluggen diameter 8 mm**

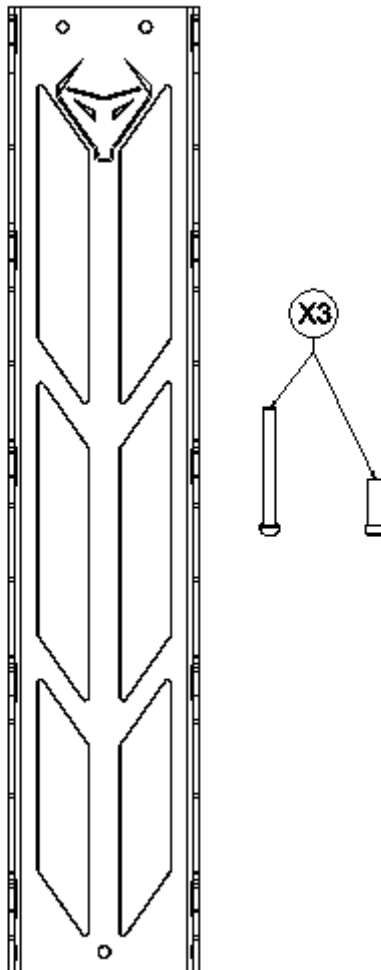

### Benodigde gereedschappen:

- Elektrische boormachine
- 8 mm boor
- Waterpas
- Kruiskopschroevendraaier

# Instructies

1. **Wandkeuze:** Kies een stevige, dragende muur om de houder veilig te monteren.
2. **Hoogteberekening:** Meet de gewenste hoogte vanaf de vloer.

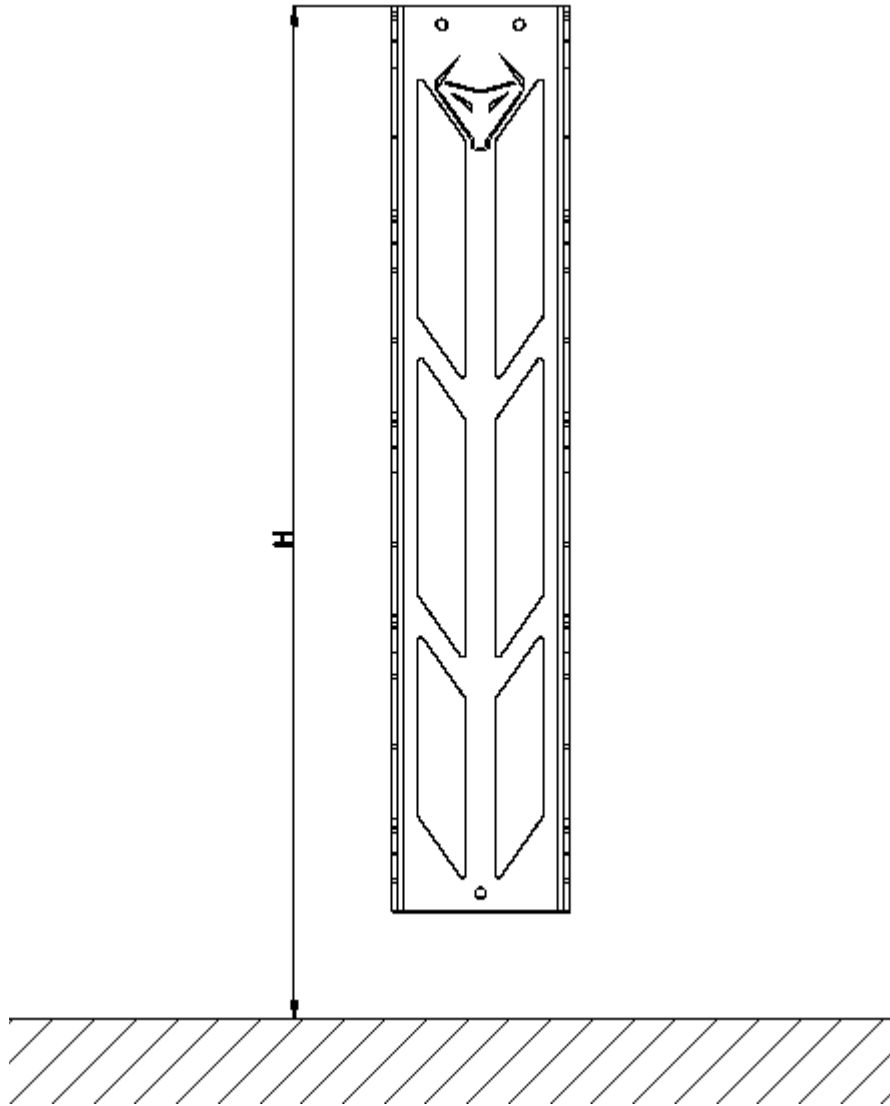

3. **Markeren en boren:** Houd de houder tegen de muur, stel hem waterpas en markeer de 3 bevestigingspunten met een potlood. Boor de gaten met de 8 mm boor.

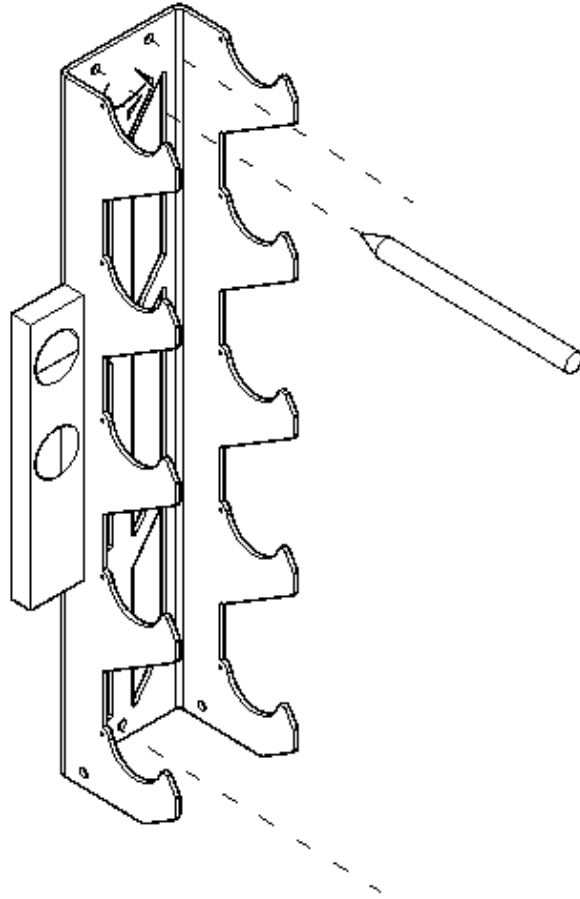

4. **Eindmontage:** Steek de pluggen in de geboorde gaten. Breng de houder op de pluggen aan, steek de schroeven door de openingen en draai ze stevig vast.

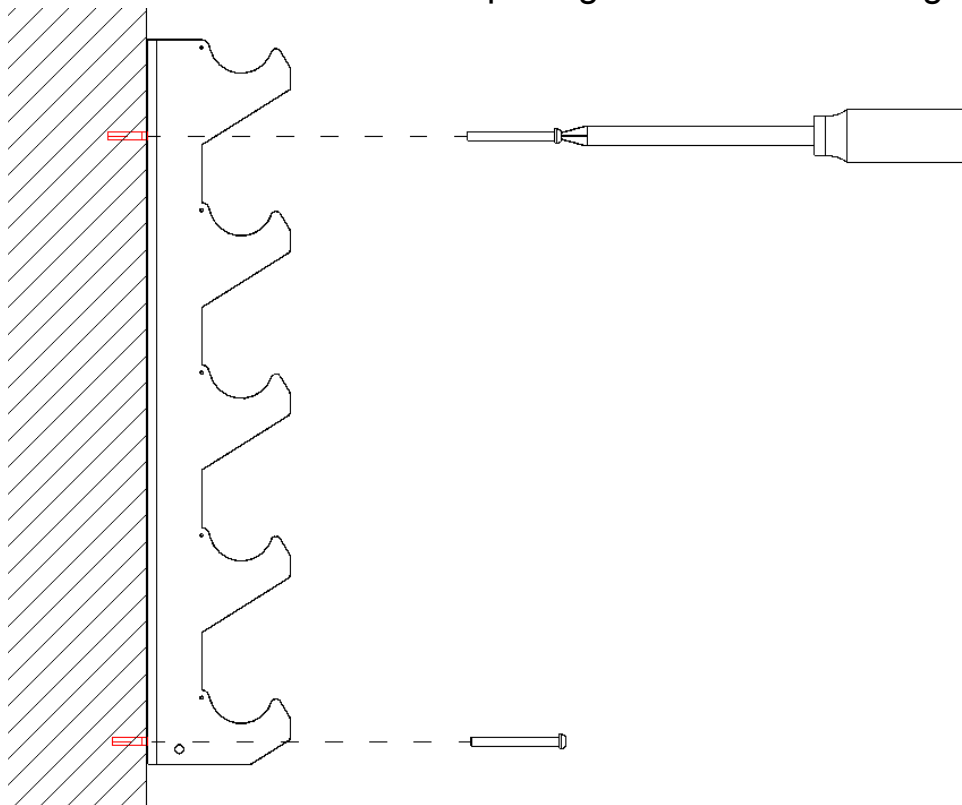

Uw **HORIZONTE** dumbbellhouder is nu klaar voor gebruik.

## Safety Information / Warnings

1. **Maximum Load:** Do not use the wall brackets to support a total combined weight exceeding 100 kg. Exceeding this limit may cause wall damage or personal injury.
2. **Mounting Location:** Install the product only on sturdy, solid walls (concrete, solid brick, or structural timber). Do not mount on drywall (Pladur/gypsum board), light partitions, or hollow surfaces, as they could deform or break under the weight.
3. **Adult Assembly:** Installation must be performed exclusively by adults with the appropriate tools. Not suitable for installation by children.
4. **Periodic Inspection:** Regularly check (once a month) that the screws and wall plugs remain tightly secured. Tighten any loose screws immediately to prevent accidents.
5. **Correct Use:** Use the rack exclusively for hanging dumbbells. Do not climb, hang, or apply body weight or other heavy objects to the structure.
6. **Keep Away from Children and Pets:** Keep children and animals away during assembly and daily use.
7. **Disclaimer:** The manufacturer is not responsible for any material or personal damage resulting from incorrect installation, overloading, or improper use of the product.

### Pictograms



W001

General warning - Read the safety instructions before use.



P010

Maximum load: 100 kg. Do not overload.



W001 + 

Fix only to solid walls - Do not install on drywall or hollow bricks.



P001

Adults only - Assembly must be performed by adults .



P013

Do not climb - Risk of detachment if hanging from the structure. .



M001

Wear protective gloves during installation.