

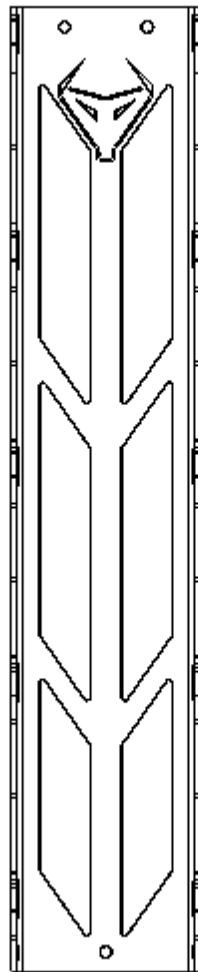

Istruzioni di montaggio

Supporto per manubri

HZ-0004



Grazie per aver acquistato il supporto per manubri **HORIZONTE** by **Lezoconcept**. Questo prodotto è stato progettato per ottimizzare lo spazio e organizzare i vostri manubri in modo sicuro ed elegante.

Contenuto della confezione:

- Supporto per manubri
- 3 viti M5 x 40
- 3 tasselli diametro 8 mm

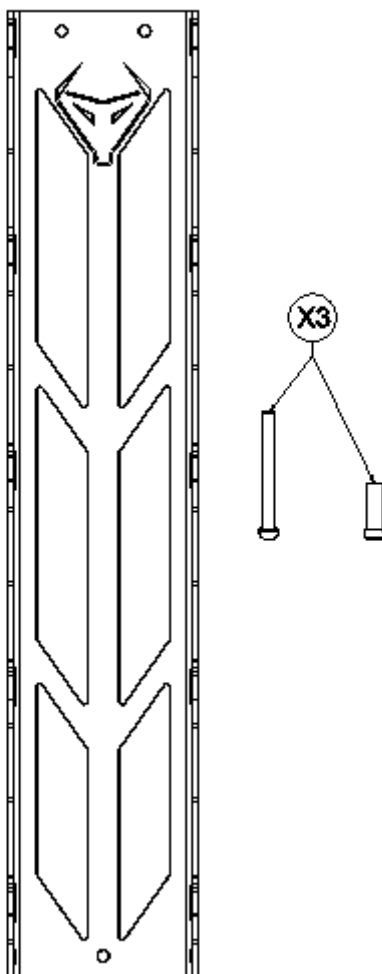

Strumenti necessari:

- Trapano elettrico
- Punta da 8 mm
- Livella a bolla
- Cacciavite a croce

Istruzioni

1. **Scelta della superficie:** Scegliere una parete solida e portante per installare il supporto in sicurezza.
2. **Calcolo dell'altezza:** Misurare l'altezza desiderata dal pavimento.

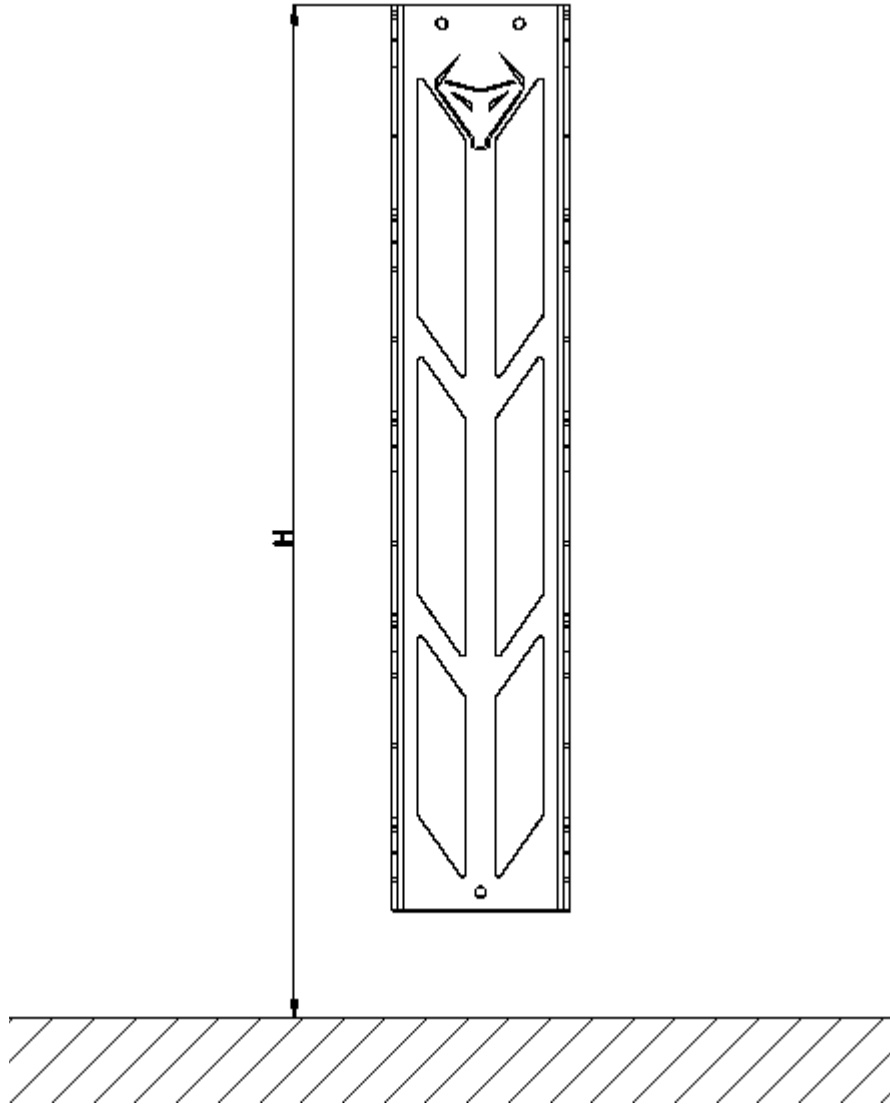

3. **Marcatura e foratura:** Appoggiare il supporto alla parete, livellarlo con la livella a bolla e segnare i 3 punti di fissaggio con una matita. Praticare i fori con la punta da 8 mm.

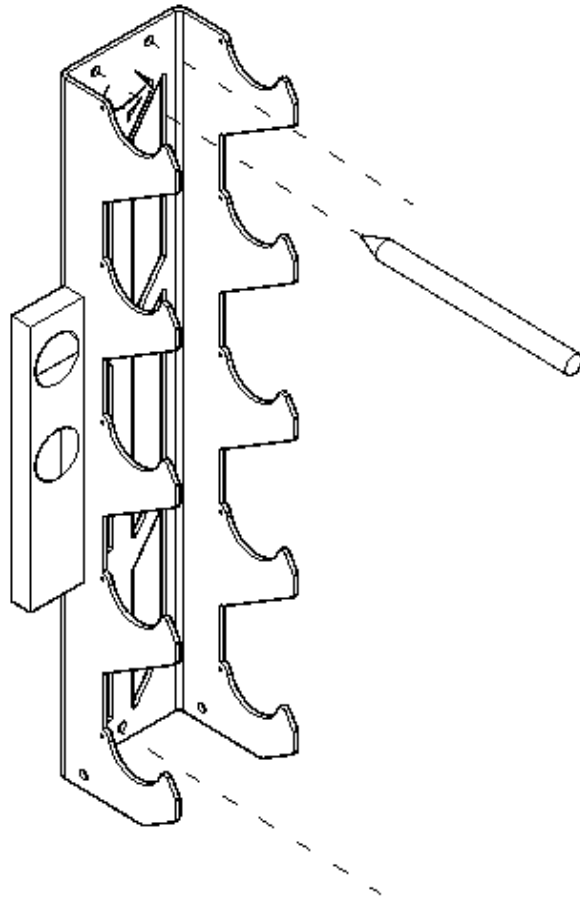

4. **Fissaggio finale:** Inserire i tasselli nei fori eseguiti. Allineare il supporto ai tasselli, passare le viti attraverso i fori e avvitare saldamente alla parete.

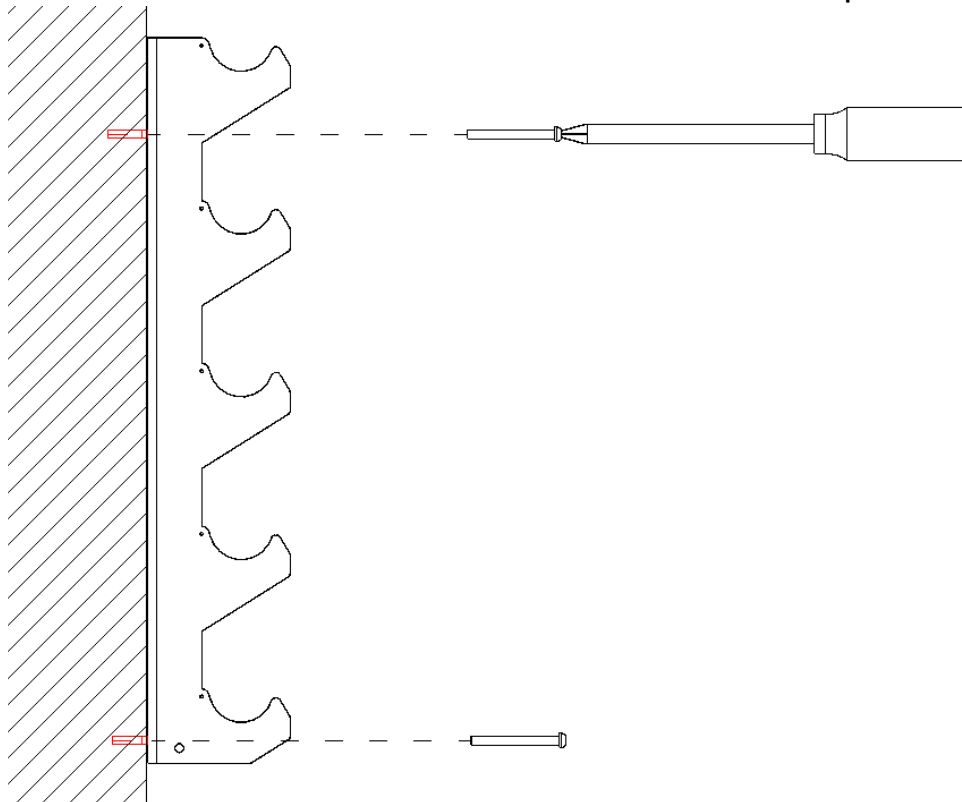

Il vostro supporto per manubri **HORIZONTE** è pronto all'uso.

Safety Information / Warnings

1. **Maximum Load:** Do not use the wall brackets to support a total combined weight exceeding 100 kg. Exceeding this limit may cause wall damage or personal injury.
2. **Mounting Location:** Install the product only on sturdy, solid walls (concrete, solid brick, or structural timber). Do not mount on drywall (Pladur/gypsum board), light partitions, or hollow surfaces, as they could deform or break under the weight.
3. **Adult Assembly:** Installation must be performed exclusively by adults with the appropriate tools. Not suitable for installation by children.
4. **Periodic Inspection:** Regularly check (once a month) that the screws and wall plugs remain tightly secured. Tighten any loose screws immediately to prevent accidents.
5. **Correct Use:** Use the rack exclusively for hanging dumbbells. Do not climb, hang, or apply body weight or other heavy objects to the structure.
6. **Keep Away from Children and Pets:** Keep children and animals away during assembly and daily use.
7. **Disclaimer:** The manufacturer is not responsible for any material or personal damage resulting from incorrect installation, overloading, or improper use of the product.

Pictograms



W001

General warning - Read the safety instructions before use.



P010

Maximum load: 100 kg. Do not overload.



W001 + 

Fix only to solid walls - Do not install on drywall or hollow bricks.



P001

Adults only - Assembly must be performed by adults .



P013

Do not climb - Risk of detachment if hanging from the structure. .



M001

Wear protective gloves during installation.