

Instructions de montage

Support pour haltères

HZ-0004

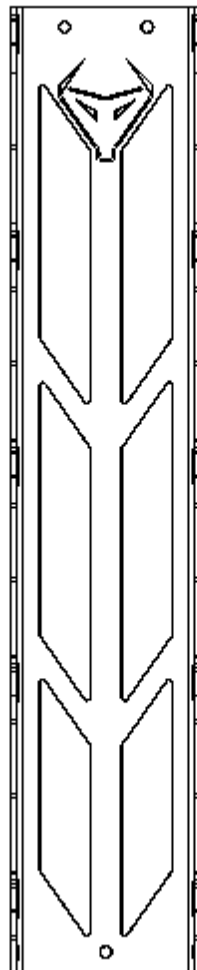

Merci d'avoir acheté le support pour haltères **HORIZONTE** by **Lezoconcept**. Ce produit a été conçu pour optimiser votre espace et organiser vos haltères de manière sûre et élégante.

Contenu de la boîte:

- Support pour haltères
- 3 vis M5 x 40
- 3 chevilles diamètre 8 mm

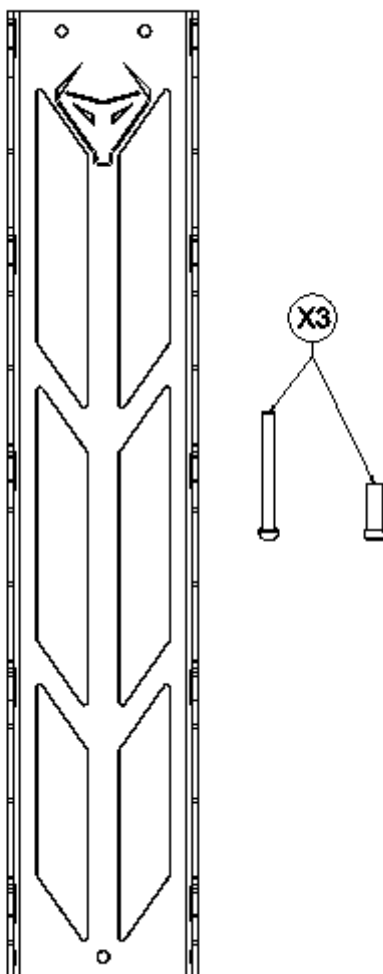

Outils nécessaires:

- Perceuse électrique
- Foret de 8 mm
- Niveau à bulle
- Tournevis cruciforme

Instructions

1. **Choix de la surface** : Choisissez un mur solide et porteur pour installer le support en toute sécurité.
2. **Calcul de la hauteur** : Mesurez la hauteur souhaitée depuis le sol.

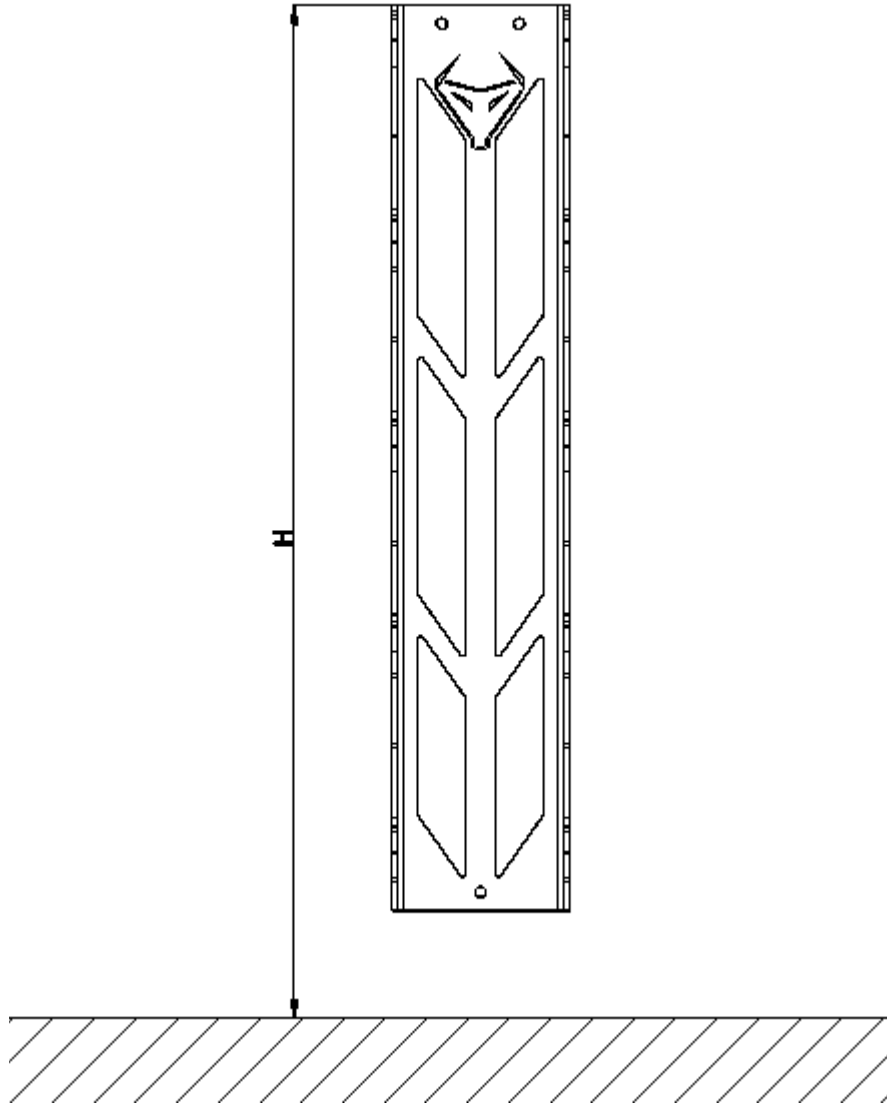

3. **Marquage et perçage** : Placez le support contre le mur, mettez-le à niveau avec le niveau à bulle et marquez les 3 points de fixation au crayon. Percez les trous avec le foret de 8 mm.

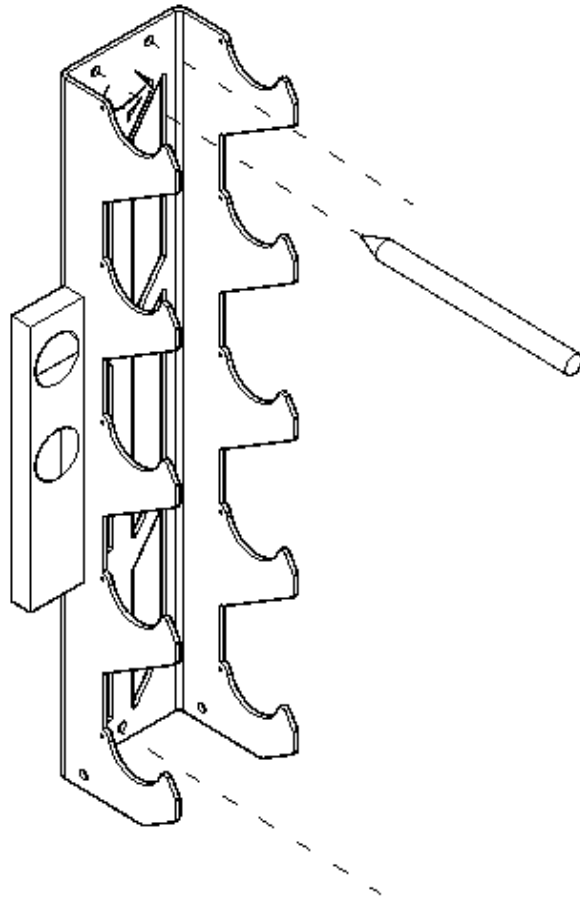

4. **Fixation finale** : Insérez les chevilles dans les trous. Alignez le support sur les chevilles, introduisez les vis dans les orifices et serrez fermement avec le tournevis cruciforme.

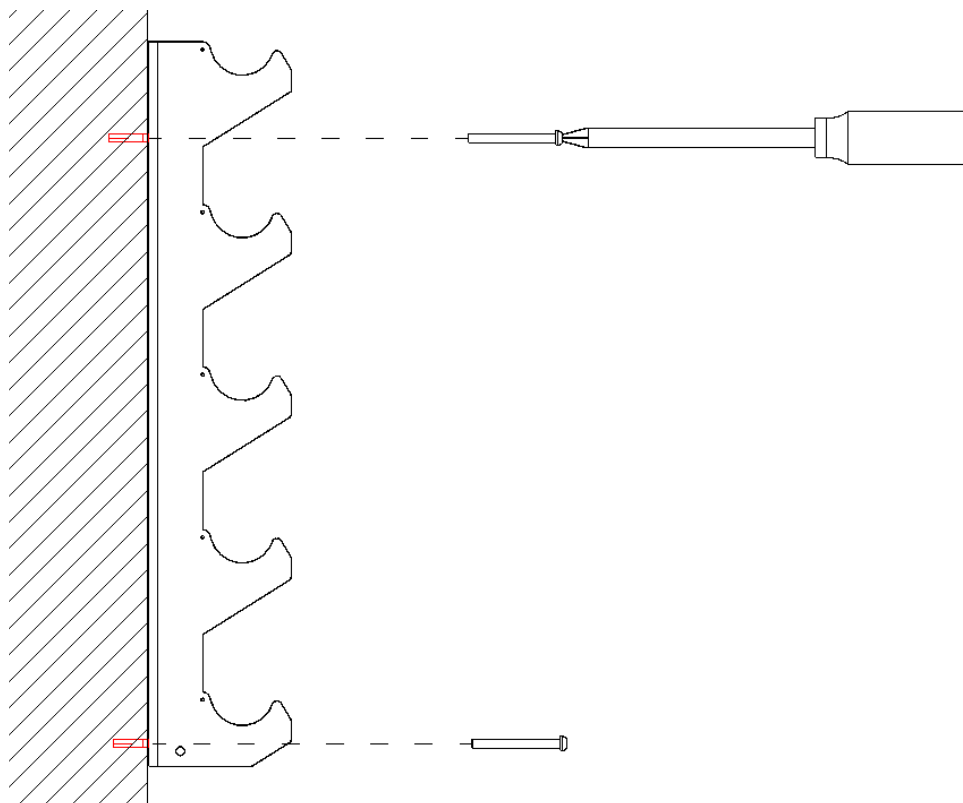

Votre support pour haltères **HORIZONTE** est prêt à l'emploi.

Safety Information / Warnings

1. **Maximum Load:** Do not use the wall brackets to support a total combined weight exceeding 100 kg. Exceeding this limit may cause wall damage or personal injury.
2. **Mounting Location:** Install the product only on sturdy, solid walls (concrete, solid brick, or structural timber). Do not mount on drywall (Pladur/gypsum board), light partitions, or hollow surfaces, as they could deform or break under the weight.
3. **Adult Assembly:** Installation must be performed exclusively by adults with the appropriate tools. Not suitable for installation by children.
4. **Periodic Inspection:** Regularly check (once a month) that the screws and wall plugs remain tightly secured. Tighten any loose screws immediately to prevent accidents.
5. **Correct Use:** Use the rack exclusively for hanging dumbbells. Do not climb, hang, or apply body weight or other heavy objects to the structure.
6. **Keep Away from Children and Pets:** Keep children and animals away during assembly and daily use.
7. **Disclaimer:** The manufacturer is not responsible for any material or personal damage resulting from incorrect installation, overloading, or improper use of the product.

Pictograms



W001

General warning - Read the safety instructions before use.



P010

Maximum load: 100 kg. Do not overload.



W001 + 

Fix only to solid walls - Do not install on drywall or hollow bricks.



P001

Adults only - Assembly must be performed by adults .



P013

Do not climb - Risk of detachment if hanging from the structure. .



M001

Wear protective gloves during installation.