

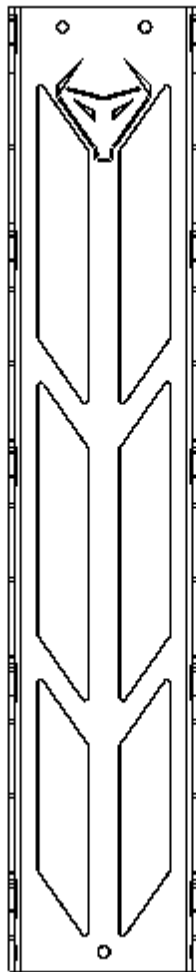

Assembly Instructions

Dumbbell Rack

HZ-0004



Thank you for purchasing the HORIZONTE by Lezoconcept dumbbell rack. This product has been designed to optimize your space and organise your dumbbells safely and elegantly.

Included in the box:

- Dumbbell rack
- 3 screws M5 x 40
- 3 wall plugs diameter 8 mm

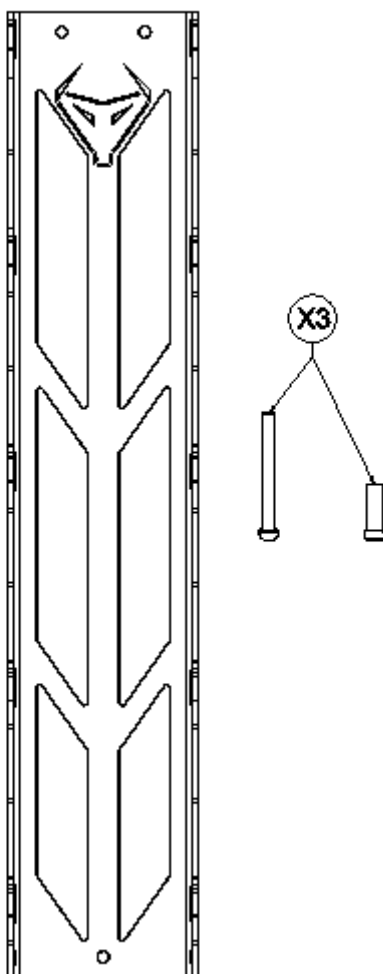

Tools required:

- Electric drill
- 8 mm drill bit
- Spirit level
- Phillips screwdriver

Instructions

1. **Surface selection:** Choose a solid, load-bearing wall to mount the rack safely.
2. **Height calculation:** Measure the desired height from the floor to where you want to position the rack.

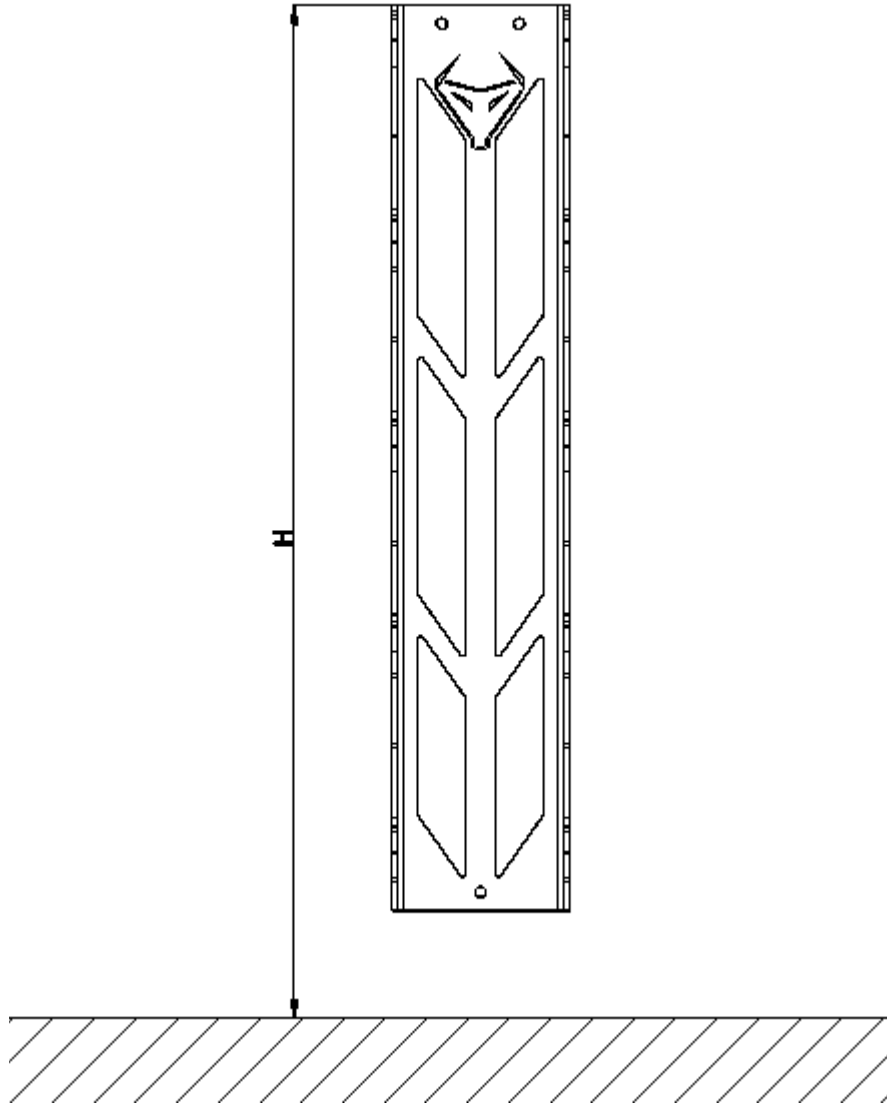

3. **Marking and drilling:** Hold the rack against the wall, level it with the spirit level, and mark the 3 fixing points with a pencil. Drill the holes using the 8 mm drill bit.

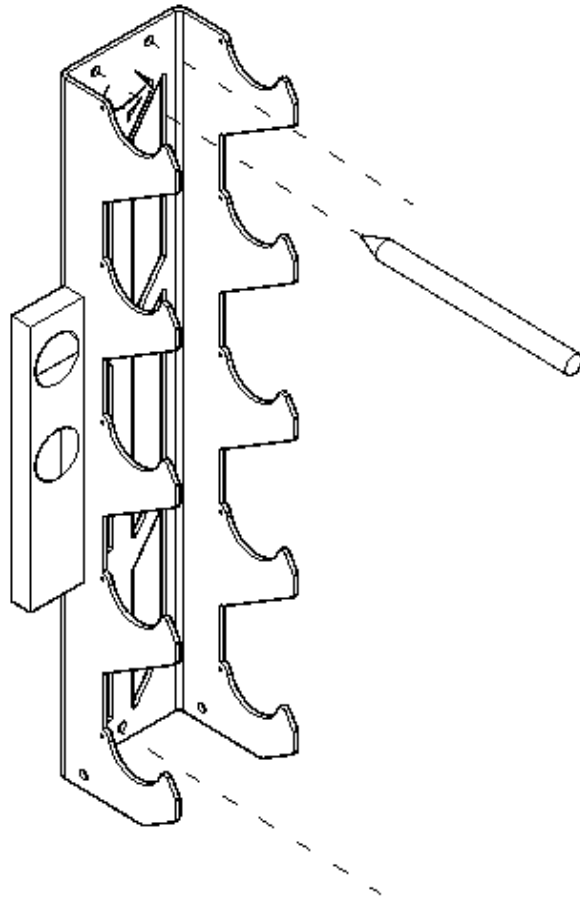

4. **Final fixing:** Insert the 8 mm wall plugs into the drilled holes. Align the rack to the plugs, pass the screws through the rack holes and tighten firmly with the Phillips screwdriver.

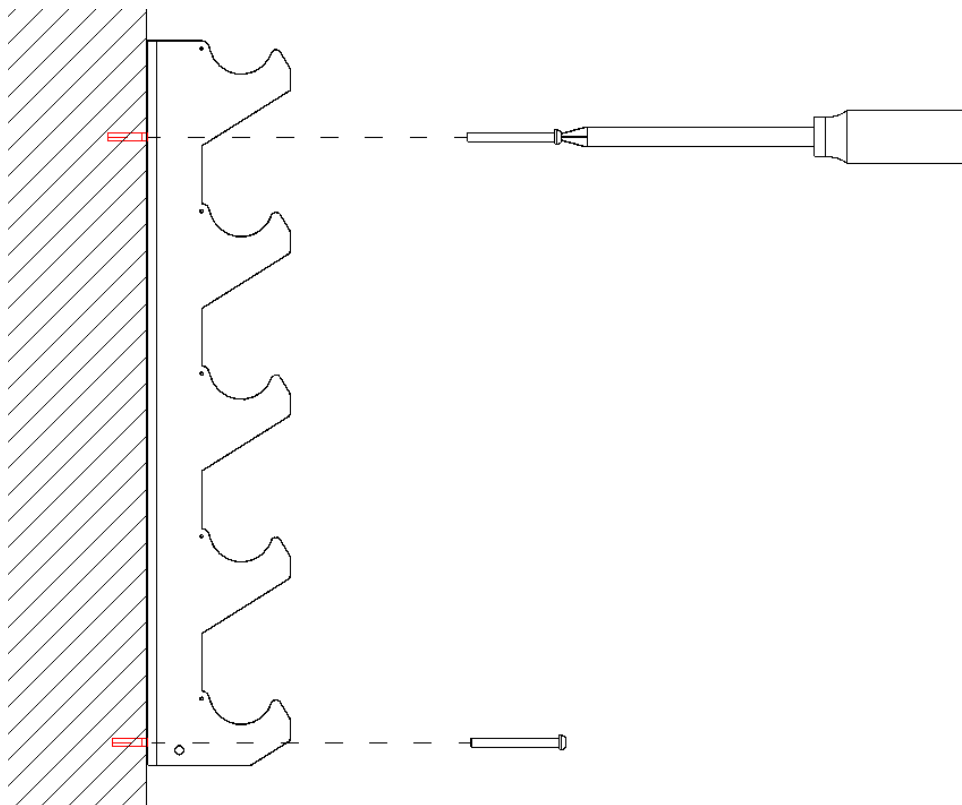

Your **HORIZONTE** dumbbell rack is now ready to use.

Safety Information / Warnings

1. **Maximum Load:** Do not use the wall brackets to support a total combined weight exceeding 100 kg. Exceeding this limit may cause wall damage or personal injury.
2. **Mounting Location:** Install the product only on sturdy, solid walls (concrete, solid brick, or structural timber). Do not mount on drywall (Pladur/gypsum board), light partitions, or hollow surfaces, as they could deform or break under the weight.
3. **Adult Assembly:** Installation must be performed exclusively by adults with the appropriate tools. Not suitable for installation by children.
4. **Periodic Inspection:** Regularly check (once a month) that the screws and wall plugs remain tightly secured. Tighten any loose screws immediately to prevent accidents.
5. **Correct Use:** Use the rack exclusively for hanging dumbbells. Do not climb, hang, or apply body weight or other heavy objects to the structure.
6. **Keep Away from Children and Pets:** Keep children and animals away during assembly and daily use.
7. **Disclaimer:** The manufacturer is not responsible for any material or personal damage resulting from incorrect installation, overloading, or improper use of the product.

Pictograms



W001

General warning - Read the safety instructions before use.



P010

Maximum load: 100 kg. Do not overload.



W001 + 

Fix only to solid walls - Do not install on drywall or hollow bricks.



P001

Adults only - Assembly must be performed by adults .



P013

Do not climb - Risk of detachment if hanging from the structure. .



M001

Wear protective gloves during installation.