

House2Start™ Gen2

12V lead-acid starting battery charger & maintainer

*compatible with flooded wet cell and AGM lead acid starting batteries
for permanent installation in motorized vehicles*

Copyright 2025 Yubie Innovations, LLC. All rights reserved. All trademarks are owned by Yubie Innovations, LLC.

Seller makes no warranty as to the accuracy, sufficiency or suitability of the information provided in this documentation. Seller assumes no responsibility or liability for any losses, damages, costs or expenses that might arise due to use of the information in this documentation. Use of this information is entirely at the user's risk.

Warranty: This product is covered by a **1-year limited warranty** from the date of purchase. The warranty covers defects in materials and workmanship under normal use. It does not cover damage resulting from improper installation, misuse, unauthorized modifications, or exposure to extreme environmental conditions. If a defect is found within the warranty period, the product will be repaired or replaced at no charge, subject to the terms and conditions of the warranty. Proof of purchase is required for warranty service.

Yubie Innovations, LLC
Berkeley, CA 94705

Support email: support@house2start.com
Web: www.house2start.com

House2Start 12V U.P.C 198715723045

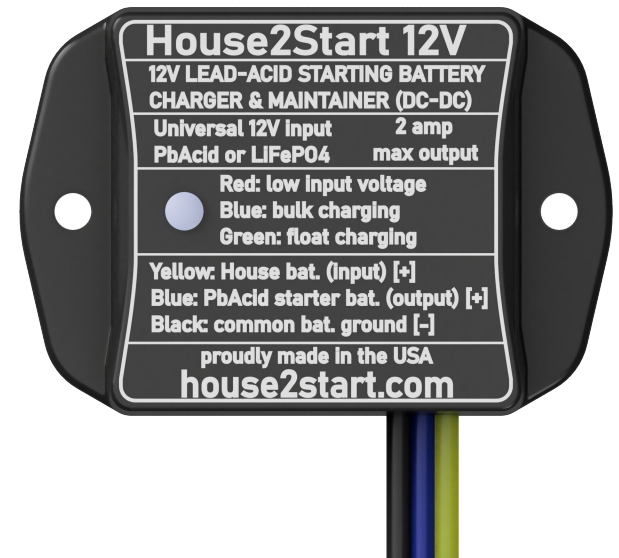

WARNING: This product can expose you to chemicals which are known to the state of California to cause cancer and birth defects or reproductive harm. For more information go to www.p65warnings.ca.gov.

IMPORTANT SAFETY WARNINGS

Read and Understand: Before installing or using this product, carefully read and understand the installation guide. It contains vital safety information. Failure to follow these instructions can result in serious injury or property damage.

Risks During Installation and Use:

- **Eye & Physical Injury:** Always wear personal protective equipment (PPE), including eye protection and clothing that covers arms and legs. Sharp tools used during installation can cause injury, and vehicle batteries may explode or leak acid, leading to severe eye or skin damage. In case of contact with battery acid, immediately flush the area with clean water and seek medical attention.
- **Electrical Shock & Sparks:** Exercise caution to avoid generating sparks or cutting live wires during installation. Sparks near lead-acid batteries can ignite explosive hydrogen gas. Use insulated tools and always disconnect the vehicle's battery, solar power, shore power, or other power sources before installation or maintenance.
- **Explosion Risk:** Using incompatible or damaged batteries may result in an explosion. Only use this product with the specified battery chemistries and voltages. Never attempt to charge frozen batteries.
- **Explosive Gases:** Lead-acid batteries emit explosive gases during normal operation. Follow all safety guidelines provided by the battery manufacturer.
- **Fire Hazard:** This power conversion product may heat up under heavy load. Ensure proper ventilation—do not cover it or install it near flammable materials or fuels.

Always disable House2Start before disconnecting or removing the vehicle starter battery.

ALWAYS disconnect the vehicle's battery systems, solar power, shore power, or other power systems before installing or maintaining the product.

FAILURE TO FOLLOW THESE INSTRUCTIONS MAY RESULT IN DEATH OR SERIOUS INJURY.

PRODUCT DESCRIPTION

House2Start (H2S) keeps a motor vehicle's starter battery charged during storage or low use, preventing deep discharge and ensuring reliable starts. It installs permanently with no user intervention and runs off the vehicle's 12V house battery, whether Lithium Iron Phosphate (LiFePO₄) or lead acid (SLA, AGM, or flooded).

The charger turns on when the house battery is above the turn-on voltage threshold and turns off when the house battery is below the turn-off threshold. There are 4 different turn-on turn-off threshold combinations to fit a wide range of use-case scenarios. The voltage threshold is configured by two electrical jumpers located on the side of the module enclosure (pg4).

An internal high-efficiency switched-mode boost converter powers a 4-stage smart charger optimized for 12V lead-acid starter batteries. The 4 stages are trickle charge for deeply discharged batteries, bulk mode (up to 2A until 14.4V), absorption mode (holding 14.4V until current decreases below 350mA), and float mode (13.5V). Charge voltages are temperature compensated at -20 mV/°C.



If the charger output is active for 40 continuous hours, the House2Start charger resets itself to ensure the starter battery receives constant-voltage "absorption" charging for longevity. House2Start is independent of the vehicle's alternator output and does not allow current flow into the house battery. The House2Start charger is non-isolated and requires a shared ground connection between the house and starter batteries.

Safety features include reverse polarity protection, current limiting, output short protection, low and high voltage shutoffs, lightning protection, thermal cutoff, and a multi-color status LED. The pre-attached 18" wires simplifies installation. It has a UL94 V-0 flame-retardant ABS enclosure, epoxy-coated electronics, and marine-grade wiring for harsh conditions.

The product is lead-free, RoHS compliant, and every unit is 100% functional tested prior to shipping.

JUMPER CONFIGURATION ON / OFF VOLTAGES

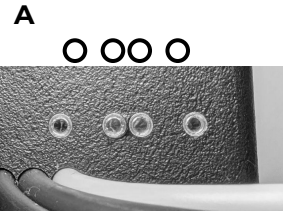
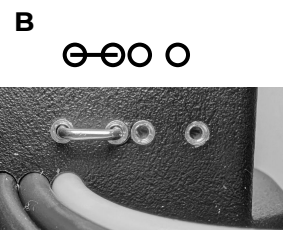
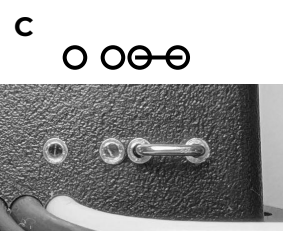
Units are shipped with both jumpers installed (**D**), to ensure they are not lost in shipping – adjust jumpers for use case per table below. Remove jumper with pliers or screwdriver. Save jumper(s). Lead acid includes Wet cell, Flooded, and AGM battery types. Visit <https://house2start.com/install> for more information.

| Jumper Setting | Charger turns on | Charger turns off | House Battery Capacity at OFF Voltage | Setting Description |
|---|-------------------------------|-------------------------------|---------------------------------------|--|
| A  | House voltage > 12.5 V | House voltage < 12.2 V | Lead Acid: 50% LiFePO4: <5% | Typically used for RVs without active shore/solar house battery charger. H2S maintains starter battery until house battery is discharged to safe limit. Recognize that without active house battery charging, with this setting, the starter battery will be maintained until the house battery voltage depletes to 12.2V. |
| B  | House voltage > 13.1 V | House voltage < 12.8 V | Lead Acid: 95% LiFePO4: 15% | Recommended for RVs with AGM house & active shore/solar house battery charger. H2S turned ON by shore/solar charging, but may stay on a short time after shore/solar charger turns off. RVs with LiFePO4: Due to higher resting battery voltage, H2S turns ON without external house battery charger; 12.8V low-voltage cutoff leaves ~15% capacity in house battery bank. |
| C  | House voltage > 13.4 V | House voltage < 13.1 V | Lead Acid: 100% LiFePO4: 65% | RVs with AGM, similar to B but ensures House2Start turns off when solar/shore charger is off. Recommended for RVs with LiFePO4 house & active shore/solar house charger. H2S turned on by shore/solar charging, and stays on even after house charger turns off. For use-cases that require modest LiFePO4 house battery reserve capacity to power important devices always active within the RV. |
| D (factory default)  | House voltage > 13.6 V | House voltage < 13.2 V | Lead Acid: 100% LiFePO4: 85% | RVs with AGM, similar to C. RVs with LiFePO4: Similar to C except charger turns off at higher house voltage (“sooner”). For use-cases that require maximum LiFePO4 house battery reserve capacity. |

INSTALLATION INSTRUCTIONS

CRITICAL SAFETY: Before installation, disconnect all solar panel power, shore power, and any other external charging sources, and the negative ground connections, on both the starter and house batteries. Failing to do so may result in injury or vehicle damage.

JUMPER SELECTION: Configure jumpers for desired turn-on and turn-off voltage thresholds (see pg 4).

FUSES: Fuse the battery connections if they are longer than the included 18" wire lengths. Install the fuse as close as practical to the respective battery. A 5 Amp ATO/ATC blade fuse is recommended.

SWITCH: A switch may be added to the yellow house wire so House2Start can be easily turned off. House2Start should always be turned off when the RV starter battery is disconnected. A removable fuse on the yellow wire can also be used to temporarily disable House2Start.

YELLOW WIRE MAXIMUM PERMISSIBLE LENGTH, DO NOT EXCEED:

16AWG: 10 feet, 14AWG: 14 feet, 12AWG: 22 feet, 10AWG: 35 feet, 8AWG: 56 feet

ELECTRICAL CONNECTIONS: House2Start requires three wire connections. For best protection, use heat-shrink adhesive-lined crimp terminals. Make the connections in the indicated order:

First connection, Blue: Connect to positive terminal of the engine starting battery or an "always on" connection point provided by the vehicle manufacturer.

Second connection, Yellow: Connect to positive terminal of the house battery or via distribution panel.

Final connection, Black: Connect to vehicle chassis ground. Both the house and starter batteries must be grounded to the chassis for proper function. Reliable low-resistance ground connection is essential for proper functioning of House2Start.

MOUNTING: Mount using the 2.50" spaced flange holes with two #8 or M4 screws, or affix module to solid surface using heavy-duty double-sided automotive adhesive, 3M VHB, or similar.

INSTALLATION INSTRUCTIONS (cont)

LOCATION: Install House2Start in a location with similar temperatures to the starter battery for accurate charger voltage temperature compensation. Minimize wire length to ground (black wire) and the house battery (yellow wire) to ensure accurate turn on and off voltage behavior. Do not install or operate near combustible fuels. Install in well ventilated location, do not cover the module, and never mount or operate House2Start on top of either battery.

WIRING: Use 16AWG or larger stranded copper or stranded tinned-copper wire. Minimize ground (black) wire length, avoid extending beyond included 18" lead. Follow proper ground bonding techniques. Use existing ground point if available, avoid bonding to sheet metal which can loosen with vibration, use star washer and corrosion inhibitor.

IMPORTANT: Read fusing & yellow wire maximum permissible length information on page 5.

Basic Installation Diagram for use without Battery Isolator or Relay Switch

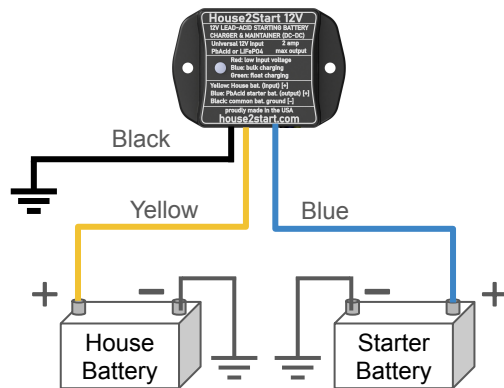

Installation Diagram for use with Battery Isolator or Relay Switch (typical RV install)

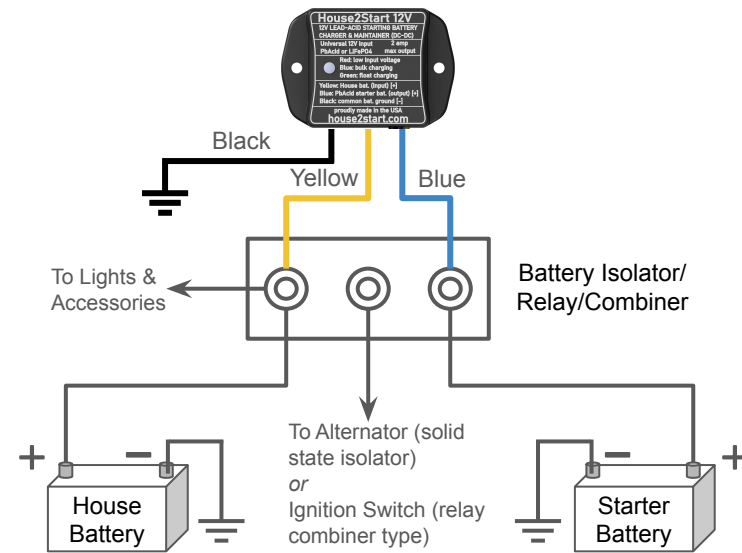

ALWAYS disconnect the vehicle's battery systems, solar power, shore power, or other power systems before installing or maintaining the product.

FAILURE TO FOLLOW THESE INSTRUCTIONS MAY RESULT IN DEATH OR SERIOUS INJURY.

OPERATION & TROUBLESHOOTING

Once installed, House2Start operates automatically, activating when the house battery voltage exceeds the selected turn-on voltage. The charger de-activates when the house battery voltage falls below the selected turn-off voltage.

Multi-color LED Indicators:

RED: Charger is off, house battery is below the turn-on threshold.

BLUE: Charger is in trickle, bulk or absorption mode.

GREEN: Charger is in float charge mode.

OFF: Possible causes include:

- 1) Incorrect installation (wires reversed, poor contact, bad or no common ground between batteries).
- 2) House battery is completely discharged (i.e. below 2V).
- 3) Input exceeds over-voltage protection limit (15 V)
- 4) Starter battery voltage exceeds 16V.
- 5) Module is off due to extreme temperature.
- 6) Module is resetting after 40 hours of continuous charging and will turn back on in 1-2 minutes.
- 7) Internal (non-replaceable) input fuse blown, caused by internal circuit failure.

TROUBLESHOOTING

LED off: incorrect wiring polarity or faulty wiring connection(s); house battery discharged

LED always RED: house battery never reaches programmed turn-on voltage; missing or faulty house battery charger; blue and yellow wires reversed

LED flashing rapidly one or many colors: poor or no ground connections; yellow house wire too long or wire gauge too small (i.e. resistance too high).

PRODUCT SPECIFICATIONS

| | | | | |
|---|--|-----------|-----------|-----------|
| Model number | House2Start-12 Gen2 | | | |
| Compatible input (house aka coach) battery chemistry | 12 V flooded/wet, sealed, AGM (lead acid) and 12 V LiFePO4 | | | |
| Compatible output (starter) battery chemistry | 12 V flood/wet or AGM (lead acid) | | | |
| Charger activation voltages (rising) | A: >12.5V | B: >13.1V | C: >13.4V | D: >13.6V |
| Charger low-voltage cutoff (falling) | A: <12.2V | B: <12.8V | C: <13.1V | D: <13.2V |
| Max charging output current | 2.3 A | | | |
| Charge voltage, absorption, nominal @ 25 °C | 14.4 V | | | |
| Charge voltage, float mode, nominal @ 25 °C | 13.5 V | | | |
| Charge voltage Temperature compensation coefficient | -20 mV/°C | | | |
| High temperature shutdown | 50 °C | | | |
| Low temperature shutdown | 0 °C | | | |
| Absolute maximum input voltage, exceeding this voltage will damage device permanently and void warranty | 20.0 V | | | |
| Internal fuses, input and output | 3.5A fast blow (not replaceable) | | | |
| Charge profile automatic reset timer | After 40 hours of continuous charging | | | |
| Dimensions | 3.05 x 2.10 x 0.96 inches | | | |
| Mounting holes | 2x 0.188 inch spaced 2.5 inches for #8 or M4 screws | | | |
| Weight | < 100 grams per unit | | | |
| Warranty | 1 year | | | |