



JV WITH KONKA
CHINESE STATE OWNED COMPANY

Energon AC200

AIO Industrial&Commercial ESS

Features



High energy, safe and scalable



Longer service life ensured by
PACK-level liquid cooling technology



Multi -scenario applications



Best LFP battery unit



Intelligent fire fighting system



Flexible working conditions, easy
to install and expand



BMS ensures safety and optimal
operation of battery systems

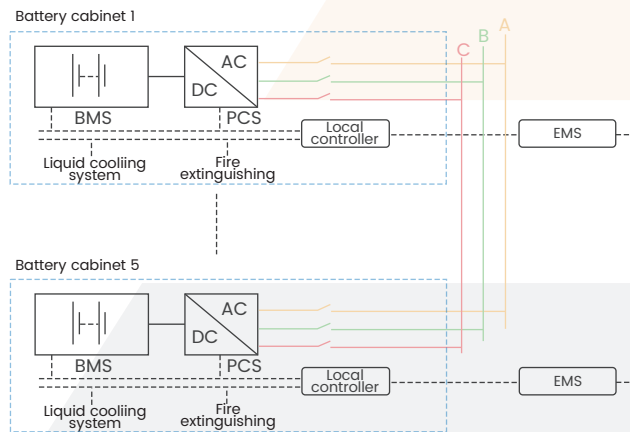
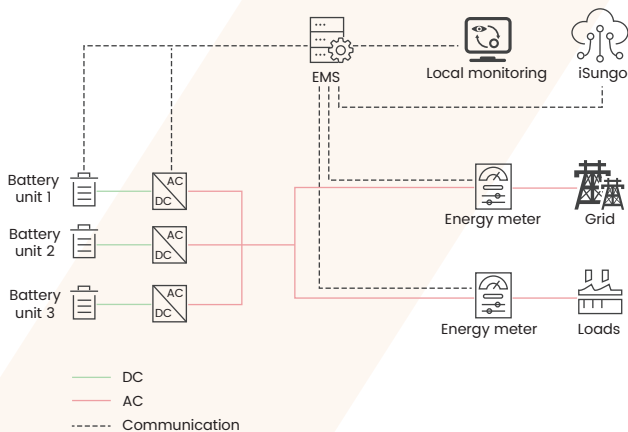
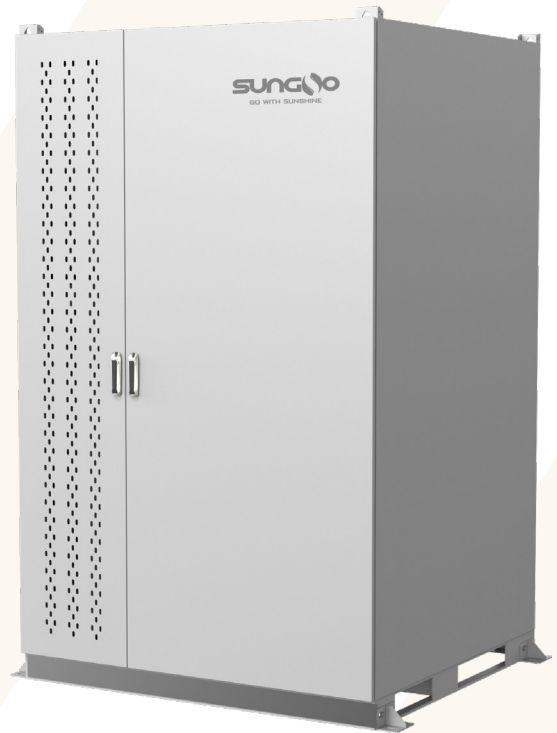



Technical Parameters

Model	Energon AC200
Battery parameters	
Cell type	LFP
System configuration of cells	240SIP
Capacity of Battery units	215kWh
Voltage range of Battery units	648~876Vdc
AC parameters	
Rated output power	100kW
THDi	<3% (Rated power)
Direct component	<0.5% (Rated power)
Rated AC voltage	400V
AC voltage range	340~460V
Rated AC frequency	50/60Hz
AC frequency range	45~55/54~66Hz
AC connection	3W+N+PE
System parameters	
Dimension (W*H*D)	1340mm*2350mm*1440mm
Weight	2200Kg
MAX efficiency	≥90%
Charge/Discharge rate	0.5C
DOD	90%
Cycle index	>6000 (100%DOD, 80%SOH)
Protection	IP54
Auxiliary power supply	Self-powered
Corrosion-proof grade	C4
Operation humidity range	5~95%, RH, without condensation
Operation temperature range	-25~+60°C
Operation altitude	2000m
Cooling	Liquid cooling
Fire extinguishing and security	Aerosol (Perfluorohexanone or Heptafluoropropane) , temperature sensors
Communication	RS485/CAN
Standards	IEC62619 IEC62477 UN38.3

If the product size and parameters change, the latest information shall prevail without prior notice.