



Elevator & Escalator

FUJI ELEVATOR GROUP LIMITED

FACTORY

No.688,Lianxi Road,Lianshi Town Nanxun, Huzhou, Zhejiang, CHINA
Tel: +8615817000671 Email: info@fujiuk.com Website: fujiuk.com

OFFICE

Room D5, 5 Floor, King Yip Factory Building, NO. 59 King Yip Street, Kwun Tong,
Kowloon HONG KONG Tel: +8615817000671 Email: info@fujiuk.com Website: fujiuk.com

OFFICE

2nd Floor College House, 17 King Edwards Road RUISLIP, London HA4 7AE UNITED KINGDOM
Tel: +447454638800 Email : info@fujiuk.com Website: fujiuk.com

SHOW ROOM







No. 71/100, Mothna Air Port St, Baghdad, IRAQ Email: info@fujiraq.com Web: www.fujiraq.com
AsiaCell: +9647710000671 ZainCell: +9647810000671 KorekCell: +9647510000671



CHINA FACTORY



IRAQ SHOWROOM

-  Passenger Elevator
-  Observation Elevator
-  Freight Elevator
-  Car Elevator
-  Villa Elevator
-  Escalator
-  Moving Walk

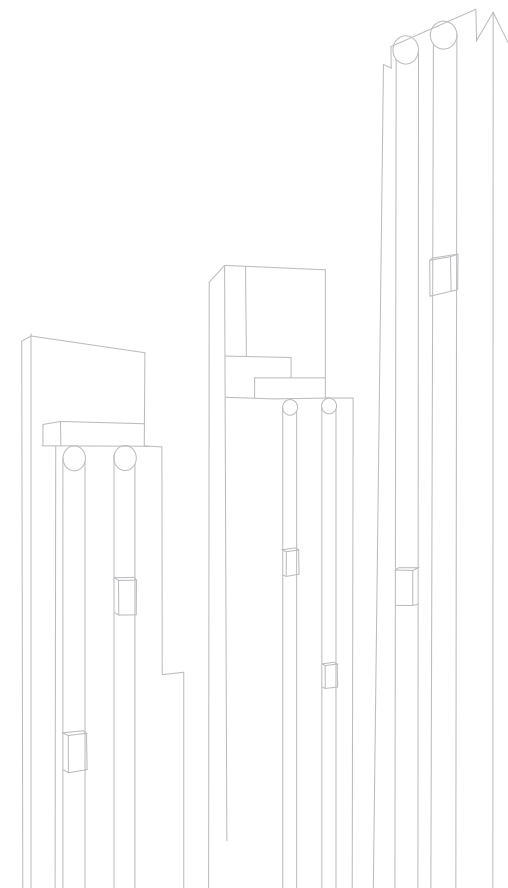

Industrial Intelligent Of 4.0 Factory Set Sail

The company has awarded dozens of titles and qualifications like "Standing Council Unit of China Elevator Association", "National Special Equipment Installation and Transform AA-class license", "National hi-tech Enterprise", "High and New Technology Research and Development Center in Zhejiang Province", "Patent Demonstration Enterprise in Zhejiang", "Well-known firms in Zhejiang Province", "Zhejiang Famous Brand Certificate", "Zhejiang Provincial Enterprise Technological Center" and so on.

FUJIGROUP Elevator Co., Ltd holds double-A qualification which are the National Special Equipment Manufacturing License and Installation Maintenance License approved by the State Administration for Industry and Commerce of the National Professional Elevator Manufacturing Enterprise. With registered capital of 300 million RMB, the company was founded in 1987, in nearly 30 years development course, FUJI GROUP has been into a period of innovation and development in building domestic machine elevator brand in the scale of production, and becoming one of the largest enterprises of the annual sales in market share.

Industrial intelligent 4.0 formal ofa new factory set sail! As the largest, and the most advanced machine equipment modern large manufacturing base in zhejiang province, the company has developed rapidly based on the independent R&D and innovation technology. Set up the product research and development center, focus on new product development, technical innovation, we uphold the faith which is dedicated to providing our customers with high-quality products and first-class service. The quality of the products from designing to manufacturing, from installation to services, are strictly controlled. To provide customers with cost-effective elevator products, also reflects the responsibility for their own deep concern and commitment!

The company, which is based on scientific and technological innovation, has won the "two-way dynamic solar photovoltaic elevator" approved by the state Patent Office for more than one hundred invention patents and utility model patents. At the same time, dozens of invention patent which are under examination and approval have been accepted.

With the ideal of harmonious integrity mutual gratitude, FUJI GROUP Elevator provides nanny services with preferential prices to achieve a win-win development. Our joint efforts is to make families enjoy a more security, environmental, comfortable of elevator delivery provided by FUJI GROUP Elevator.

Invested nearly 1 billion RMB, the four stages of the project covers an area of nearly two hundred mu, with total construction area of 80000 square meters, has a new type of vertical elevators, escalators, automatic sidewalks, article 6 of the world's advanced fully automated production line, R&D center, intelligent office building and 150 meter-high elevator testing tower equipped elevator with speed of 10 meters per second. Intelligent layout in accordance with the standards of world class factory, taking lead in introducing industrial 4.0 concept, making the production capacity is improved that the annual output of 50000 sets of all kinds of elevator machine, 5000 sets of parking equipment and 20000 sets of elevator accessories production capacity.



Scan to visit our factory



Introducing International Top Equipments And Make “made In China” affect The World



Optical fiber laser cutting machine production line



Car wall automated assembly line



CNC bending machine



Italy imported SALVANINI flexible sheet metal processing production line



KUKA robot Made in Germany



Escalator production workshop



Spraying Line (German WAGNER Spraying Room)

As the largest and the most advanced machine equipment of the modern large manufacturing base in ZheJiang Province, company introduced SALVANINI and a series of the world's leading fully automated production lines, will be fully implemented 4.0 intelligent manufacturing industry, also reveals the enterprise in the field of "machine substitution" solid results.

Achieve the annual output of 50000 sets of elevator machine, 5000 sets of parking equipment and 20000 sets of elevator accessories production capacity.



The brilliant course mold supreme quality

FUJI GROUP keep pace with you, and develop together. Towering temper, come a powerful journey of glory!

FUJI GROUP Elevator always adhere to the quality consistent product manufacturing standards and transcend the service standard of the industry, integrating global resources with high quality. Standing in the stage of new era, FUJI GROUP Elevator creates a unique brand of high-end elevators with higher attitude and idea for global customers to provide distinguished elevator products and services.



The enterprise restructured to system of contracted responsibility.



Enterprises to achieve cooperation with foreign technology, the introduction of advanced control technology, changed its name to Zhejiang Hengda Fuji Elevator Co., Ltd.

And further integration of foreign negotiations, to achieve technical and capital cooperation in the field of consistency, renamed the Sino-foreign joint venture Zhejiang Hengda Fuji Elevator Co., Ltd.



Registered capital increased to 120 million, and renamed to FUJI GROUP Elevator Co., Ltd.



With the full realization of production management and brand enhancement, the company step into the first-class elevator brand manufacturers.



Company take lead in internet of thing censorship in elevator running in the industry, make real-time tracking in elevator using 24 hours a day, broke through the blank of not using real-time tracking in elevator using.



In 2016, the new factory of FUJI GROUP Elevator's FUJI GROUP Elevator, which was more than 200 acres, was officially completed, and the future of Hengfu will be opened.



IRAQ sale agent visit FUJI factory in CHINA

1987 1993 1998 2004 2008 2009 2010 2012 2013 2014 2015 2016 2018 2023

1987



Huzhou Hengda elevator factory was established to create a "FUJI" brand new brilliant road.

1998



Enterprise changed its name to Zhejiang Hengda Elevator Co., Ltd.

2008



Enterprises to achieve restructuring, bear the courage for the first, to climb the peak of the industry mission.

2010



Invest 180 million RMB, covers an area of one hundred meters test tower height of meters Three plant completed.

2012

2013



Company's registered capital increased to 200,000,000 RMB, annual production capacity to 20,000 units, and the full implementation of modern management and operation.
FUJI GROUP was established, and the administered Fuji Group Elevator Co., Ltd. DAZO Elevator Co., Ltd. etc.

2014

2015



Company officially promoted in December 2015 to become China's Elevator Association governing units. And become enterprise signed the first local and elevator safety liability insurance coinsurance, future factory each elevator has PICC escort.

2016

2018



FUJI GROUP was once again awarded the New Elephant Award from the local government. At the same time, it won the honorary title of Huzhou City Taxpayer, which reflects the social value of the company.

2023

150 meters meet 10 m/s ultra-high speed elevator testing tower, in domestic leading position.

HIGHER, FASTER
EXPERIENCE,
SAFER FROM THE
FUJI TECHNOLOGY

Elevator & Escalator



Environmental protection

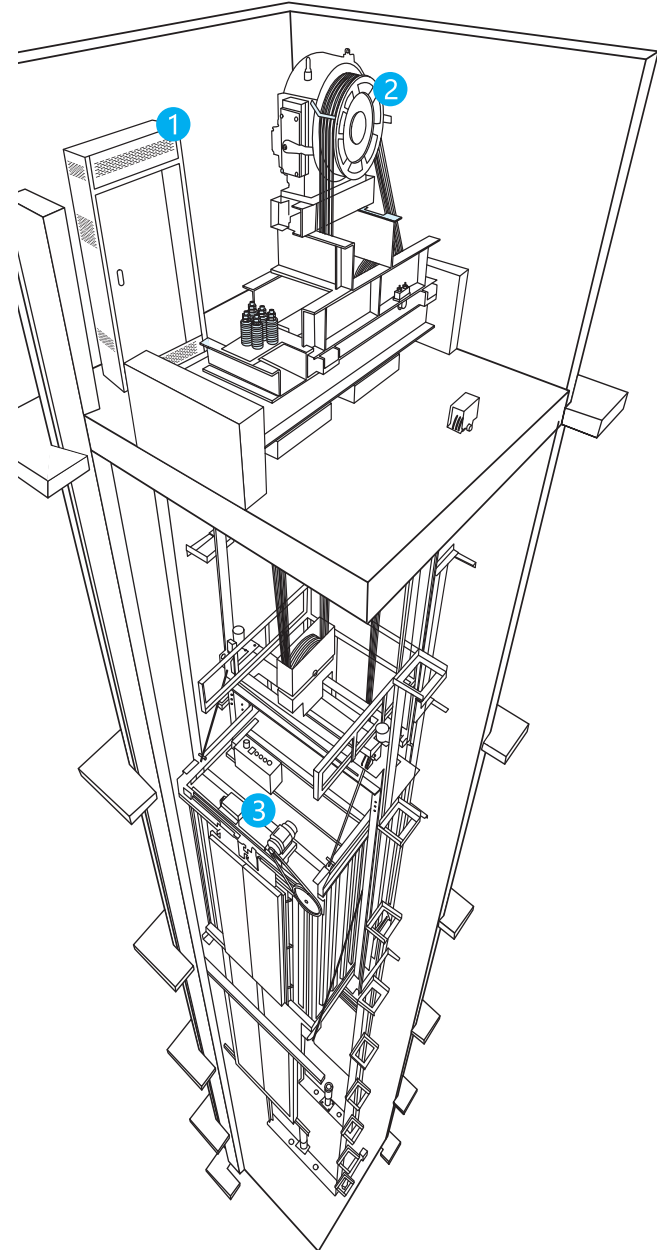

Safety

We Fuji Group Elevator every day tens of millions of people ride our products, we are committed to maintaining the safety of each elevator transport, and track the operation of each elevator.



Safety of our products and services

FUJIHD is actively involved in the development of codes and standards that aim to further improve the safety of the equipment. We enhance the safety of FUJIHD products and services through rigorous attention to our design, manufacturing, installation, and maintenance processes.

Modernization keeps elevators, escalators and automatic doors running smoothly throughout the lifetime of your building. It ensures that equipment works safely and reliably with minimum disruption. With small upgrades your old equipment can be brought up to date with the latest safety standards.



User safety

We are strongly committed to safety and work closely with the people who rely on our products for safe and smooth transport as they go about their day. One way we promote safety is by organizing annual events that give people the opportunity to get to know how elevators and escalators operate and how to use them safely.

Elevator and escalator users also need to pay attention to their own behavior. For example, children should be properly supervised when using both elevators and escalators, and large items such as baby strollers, heavy luggage, or shopping carts should not be transported on escalators.



Safety of our employees

At FUJIHD, we focus on making sure every one of our employees has the necessary competence to perform their work in a professional and safe manner. All employees receive training to a general level in health and safety, as well as training relevant to their respective work roles and tasks.

To support continuous improvement in FUJIHD's safety performance, a procedure is in place to report and investigate accidents. The underlying root causes are identified and corrective actions implemented to ensure that the accident or near-miss incident is not repeated. As a result, we have improved our safety performance steadily over the years.



Elevator object network monitoring system

Elevator networking is to solve the current elevator safety issues proposed concept, data acquisition part, data transmission part, the central processing part and application software together constitute a complete elevator object monitoring system.

Acquisition instrument to collect the elevator running data analysis and upload to the Internet monitoring center, combined with platform application software, in order to achieve the relevant units of the elevator real-time effective supervision and maintenance.



Testing center

We have professional testing equipment 11, to undertake the detection of elevator locks, door machines, floor doors, speed limiters, photoelectric switches, buttons, traction wire rope, escalator roller, handrail, metal mechanical properties, salt spray test project 20 Balance item According to the development needs, the testing center this year will also plan to introduce a number of vibration testing equipment and other testing equipment, and constantly expand the scope and ability to detect. Testing Center in the "scientific management, standards, objective and fair, accurate and timely" approach, strict control management, to meet the company's production and quality inspection needs, but also have other users to provide the same project testing services.

Green energy saving

Automatic lighting of LED energy-saving lamp

We use energy-saving LED lamp. When nobody uses the elevator, the lighting in the car will turn off automatically & automatically turn on once receiving any calling commands. Saving the electricity energy consumption sufficiently.



Sterilization function

Applying advanced environment protection technology, PM2.5 dust in the air etc. will from to molecular clusters and sink to the ground by anion. It will lessen the bacterial survival ability or kill bacteria. Timing sterilizing and air cleaning improve the cabin environment.



Energy feedback system

Energy regenerating feedback technology of LHEC can recover and re-use as high as 30% energy that has been consumed by the elevators. Especially in the elevator no-load up-motion or full-load down-motion, the electric energy that has been produced by the motors is transformed into resistance heat and only be wasted in vain. Energy regenerating feedback device converts electric energy into normal current that coincides with electric grid. Therefore these newly-produced current can be used in other power equipments in the building. It fulfills a genuine energy-saving effect.



Electromagnetic compatibility without interference with each other

FUJI GROUP passenger elevator control system fully abides by the relevant electro-magnetic compatibility standard, removes the electromagnetic pollution, effectively prevents from the electromagnetic wave interference between the elevator signals and various precision electrical equipments in the building.

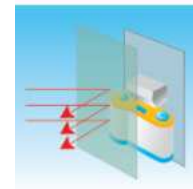

FUJI the best solution

Elevator & Escalator

— Residence

-  Passenger elevator
-  Observation elevator

Anhui Lu An Baizhuang ·spring Blossom



FUJI 
Elevator & Escalator

- Date of Completion: 2016
- Location: An Hui, China
- Product: Machine room-less elevator, Small Machine room elevator

LU AN BAIZHUANG SPRING BLOSSOM IS LOCATED IN bridge tower which is in the north direction of development, the project east face to MEISHAN road, west to the p.i river road, south next to LIUYUAN road, north depends on planning YAOLI road, adjacent to the 1.8 km water resources. The project covers an area of 266 mu, total construction area of 574000 square, plot ratio 2.68, 35% green area, residential area equipped with multi-layer elevator and senior houses and elegant amorous feelings, create a market of low density community quality scale, original ecological natural living environment.

Bring the residents back to the most casual life state, the layout of the entire park is clever, in all of landscape garden design, to fully demonstrate a kind of dynamic equilibrium composition, rare pure British classical architectural style, from British classical architectural style, recreate British dynasty aristocratic demeanor.



FUJI GROUP Elevator provide 79 sets of intelligent high quality elevators for this project, promoting the quality of residential area, at the same time, provide users efficient, safe and reliable way of life. In addition, in the elevator product design fully consider the harmony of people and the environment, detail place is embodied humanistic care, to provide more comfort for enterprises in the project owner safe riding experience!

FUJI  Reliable Elevator Suppliers — Project Achievement

FUJI the best solution

Elevator & Escalator

— Office building

-  Passenger elevator
-  Observation elevator
-  Freight elevator

Tanzania- Mzizima Tower T1



FUJI 
Elevator & Escalator

Tanzania- Mzizima Tower T2



FUJI 
Elevator & Escalator

- Date of Completion: 2012
- Location: Tanzania
- Product: Machine room-less elevator





MZIZIMA TOWER was designed according to the comprehensive luxury residential and commercial building, covers an area of 4995 square meters, total construction area of 51780 square meters, building total height of 102.8 meters. Building with its spectacular, the modelling of imposing manner is grand and has contemporary feeling extremely, to add a landscape in Dodoma. Prominent European classical luxury grand design combined with modern taste, marked by the Roman beam and arch system, through the characteristics of line highlight its forceful high precision and in level, form, and combination of the space, to show the building with grand and memorial.

FUJI  Reliable Elevator Suppliers — Project Achievement

FUJI the best solution

Elevator & Escalator

— Hotel

-  Passenger elevator
-  Observation elevator
-  Freight elevator
-  Car elevator
-  Escalator

The Manor

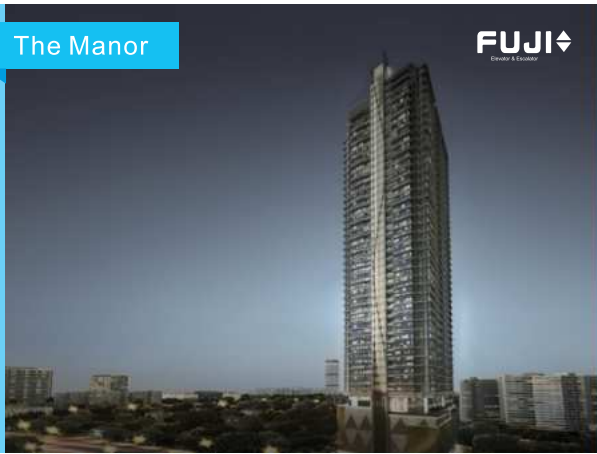

- Date of Completion: 2018
- Location: Malaysia
- Product: Small Machine room elevator
49 floors, 4 meters per second speed







The manor project is a five-star hotel-style apartment near the Kuala Lumpur Twin Towers with luxurious night views and a convenient location in the city center. FUJIHD designed a high-speed passenger elevator with a speed of 4m / s for this building. The perfect product design uses an inner rotor. The traction machine reduces the noise and energy consumption by more than 40%. This design scheme allows users to use the elevator safer, faster and more comfortable.

FUJI  Reliable Elevator Suppliers — Project Achievement

FUJI the best solution

Elevator & Escalator

— Shopping center

-  Passenger elevator
-  Observation elevator
-  Freight elevator
-  Car elevator
-  Escalator
-  Moving walk







One Batam Mall is the largest shopping mall in Batam. The mall has a total of 5 floors and 3 underground floors with 48 high-quality escalators and 6 moving walkways. The escalator and moving walkway decoration style, this project uses FUJIHD intelligent VVVF system and AUTO START system, saving more than 40% of energy consumption, making customers more comfortable, safe and convenient.

FUJI  Reliable Elevator Suppliers — Project Achievement

FUJI the best solution

Elevator & Escalator

— Hospital

-  Passenger elevator
-  Observation elevator
-  Bed elevator
-  Escalator

People's Hospital,yubei District,chongqing



- Date of Completion:2017
- Location:Chongqing,China
- Product: Small Machine room elevator, Machine room-less elevator, Escalator.

Yubei District people's hospital in Chongqing is an integrity national second-class hospital with a history of over 60 years,combine medical treatment, teaching, scientific research, prevention, health care and so on, and is the medical technical guidance center of business and emergency medical center of the whole district .Contain 400 employees,including 320 technician,5 senior titles,56 deputy high title, 92 middle title, 10 master degree candidate. Hospitals authorized bed of 265 sets, open 360 beds.Annually outpatient service over 250000 person-time, annually receive and cure inpatient more than 20000 cases .

FUJI the best solution

Elevator & Escalator

— Home use

-  Passenger elevator
-  Villa elevator

Yosemite Villa Zone



- Date of Completion:2016
- Location:ShanDong,China
- Product: Villa elevator







Yosemite club and villas are invested by SHANDONG LUNENG group, Yosemite villa covers an area of 1000 mu, possess 455 sets of villas and 80 sets of apartments, there will be another 136 sets of new Chinese style villa later.Yosemite is the start of your dream. Yosemite has convenient traffic, close to JINGSHUN road,JINGCHENG high-speed,airport high-speed, can reach capital airport or city center business district very fast.

One thousand mu scale only cover single-family, private courtyard, enjoy nature,hug neighborhood.

FUJI the best solution

Elevator & Escalator

— Infrastructure

-  Passenger elevator
-  Observation elevator
-  Freight elevator
-  Car elevator
-  Escalator
-  Moving walk

Muscat International Airport



- Date of Completion: 2011
- Location: Muscat, Oman
- Product: Freight Elevator

Muscat International Airport (Seeb International Airport; intermediate code: MCT; four word code: OOMS) (formerly called: Seeb International Airport) is one of the main Airport in Oman Muscat. The airport is the airline hub airport. From the old Muscat 30 km and mainly residential area 15 kilometers. This airport is in expanding and modernization. The airport will increase from twelve million to forty-eight million. On February 1, 2008, the airport was renamed Muscat international airport.

Project Achievements

FUJI GROUP Engineering, Accelerate The World

In the field of vertical transportation industry, We are acting excellent quality, Strict management, Perfect after-sales service to win the trust from customers, We are also adopting the high technology which lead us stand at the top in the market.

To attain the perfect design, experienced construction team, creating FUJI GROUP Elevator the world today all over the country works towards the case. Increasing domestic demand from the old installation of lifts, and high-level government buildings, high-rise commercial buildings to foreign countries, FUJI GROUP Elevator in the world has an irreplaceable position. FUJI GROUP will continue to create a safe and comfortable for human life to the next elevator ahead.

Asia



IRAQ ERBIL ATLANTIC CITY



Karachi-ITC PALAZA



IRAQ BAGHDAD MANSOUR MALL



IRAQ KUT ALKARAMA HOSPITAL



Thailand-Pattaya Hotel



Saudi Arabia-Astro Complex



IRAQ BAGHDAD MINISTRY OF INTERIOR MAIN OF DATA CENTER



Laos-Lake Pha That Luang shopping plaza

編號 3342481

No.



公司註冊處
COMPANIES REGISTRY

公司註冊證明書
CERTIFICATE OF INCORPORATION

本人謹此證明
I hereby certify that

FUJI Elevator Group Limited

於本日根據香港法例第622章《公司條例》
is this day incorporated in Hong Kong under the Companies Ordinance
在香港成立為法團，此公司是一間
(Chapter 622 of the Laws of Hong Kong), and that this company is
有限公司。
a limited company.

本證明書於二〇二三年十一月二十七日發出。
Issued on 27 November 2023.

香港特別行政區公司註冊處處長鄧婉雯

Miss Helen TANG

Registrar of Companies
Hong Kong Special Administrative Region

註 Note:

公司名稱獲公司註冊處註冊，並不表示獲授予該公司名稱或其任何部分的商標權或任何其他知識產權。

Registration of a company name with the Companies Registry does not confer any trade mark rights or any other intellectual property rights in respect of the company name or any part thereof.



CERTIFICATE OF INCORPORATION
OF A
PRIVATE LIMITED COMPANY

Company Number 15835273

The Registrar of Companies for England and Wales, hereby certifies that

FUJI GROUP LTD

is this day incorporated under the Companies Act 2006 as a private company, that the company is limited by shares, and the situation of its registered office is in England and Wales.

Given at Companies House, Cardiff, on 12th July 2024.

The above information was communicated by electronic means and authenticated by the Registrar of Companies under section 1115 of the Companies Act 2006



Companies House



THE OFFICIAL SEAL OF THE
REGISTRAR OF COMPANIES

Passenger Elevator-Profile

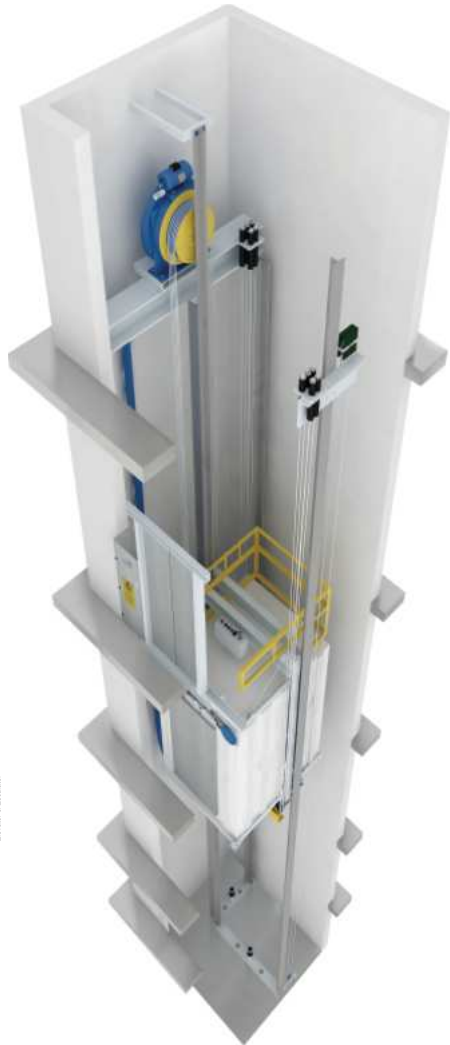

FUJI GROUP machine roomless passenger elevator cancels the machine room, reduces total area of the elevator equipment and flexibly utilizes the effective space. It has stronger contemporary sense and more beautiful construction outline.

The host and control device are designed at the shaft top to prevent from occasional water-inlet in the shaft which damages the drive device. In this way, it guarantees a highly reliable system.

**Blended into the construction,
easily and leisurely**

FUJI GROUP machine roomless passenger elevator need only one independent hoist-way and do not need the presence of machine rooms. Architects and develop-ers are allowed to conduct designing in a freer way.

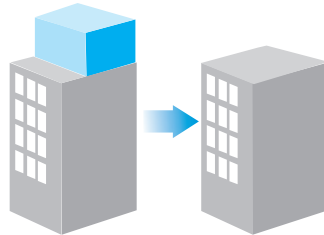

We cancel the machine room to freely design the shaft position. We can flexibly and effectively apply the top space which was preset for machine room.

Passenger Elevator-Profile

FUJI GROUP small machine room passenger elevator only has about 65% ~ 70% of the traditional machine room. It greatly saves building space and material. Control cabinet in machine room is designed into single-face inspection layout. The host bearing beam can also be used as hitch plate .It largely saves the machine room space. Compared with the traditional elevators, under the premise of ensuring the repairers' operation space which is stipulated by the national standard, it effectively controls the machine room height. The intensive space effect grants more freedom for the architects. it expand are the larger space utilization to the construction, perfectly merges the well space with the architectural style.



**Less space,
faster construction**

Compared with FUJI GROUP small machine room elevator, machine room is only an extension of the elevator well. It brings about more convenient installation, the lower cost as well.

Impressive energy savings

Compared with the traditional traction machine, FUJI GROUP small machine room elevator consumes less energy and lowev loss in heat energy.

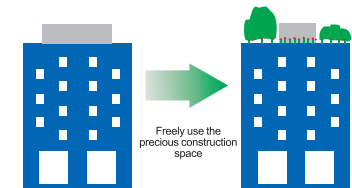

1 Intelligence system the genius in the city

Integral control system represents the developing orientation of the elevator control system. It is a new generation of intellectual vector type integral control system. It covers distance control, direct parking, closed-loop vector control technology, CANBUS communication technology, multi-CPU running technology and applies C and assembly language programming. It perfectly combines the contemporary industrial control technology, communication technology and traditional elevator. Compared with the traditional elevator control system, it brings about a high price and performance ratio and more convenient maintenance.



2 Permanent magnet synchronous gearless traction machine

We choose rare earth material and fully combine coaxial transmission technology and digital variable frequency technology with group computer combined control technology. With less running cost & less energy dissipated. Compared with the ordinary and traditional technology, Gearless traction machine can save more than 33% of the energy. Gearless traction machine needs no renewal of lubricant, No grease pollution, low noise, quiet & natural.



3 Top advanced door operator system

FUJI GROUP elevator applies the advanced VVVF variable voltage and variable frequency control technology to the elevator door operator system so as to ensure the smooth elevator door and quiet switch. What is more, the self-learning door load detector increases the sensitivity of the elevator door switching on/off. It monitors the variation of elevator door load on every floor. Automatically rectifying the most appropriate open shut speed in every floor so as to guarantee the security and reliability.



Passenger Elevator Standard Car Decoration

The unique hairline stainless steel car made by FUJI GROUP mixes with a distinctive ceiling creates exciting visual effects and bright contemporary look.



HD-KT-2104

Standard

Ceiling: Diamond silver sprayed steel plate with acrylic transparent board (HD-DTA01)

Control panel: Integrated control panel (HD-C12)

Car: Hairline stainless steel

Car door: Hairline stainless steel

Floor: PVC (FJ-B01)

Car height 2.4 meters

If there is a need for configuration replacement, please call the company for detailed consultation



Scan to know more
information



Landing door and jamb:

Hairline stainless steel is adopted for the first floor and plastic jet steel plate is adopted for other floors.

Passenger Elevator Car Decoration (optional)



Scan to know more information

HD-KT-2105

Ceiling: Diamond silver sprayed steel plate with acrylic transparent board (HD-DDB04)
Control panel: Integrated control panel (HD-C12)
Car: Stainless steel with hairline on both sides, mirror-etched stainless steel in the middle of the rear wall
Car door: Hairline stainless steel
Floor: PVC (FJ-B01)



Scan to know more information

HD-KT-2106

Ceiling: Diamond silver sprayed steel plate with acrylic transparent board (HD-DDB05)
Control panel: Integrated control panel (HD-C12)
Car wall: Stainless steel with hairline on both sides, mirror-etched stainless steel in the middle of the back wall
Car door: Hairline stainless steel
Floor: PVC (FJ-B01)



Scan to know more information

HD-KT-2107

Ceiling: Diamond silver sprayed steel plate with acrylic transparent board (HD-DTA21)
Control panel: Integrated control panel (HD-C12)
Car wall: Mirror stainless steel + modern gray style steel plate (rear wall) wood grain color makeup steel plate (side wall)
Car door: Mirror stainless steel
Floor: PVC (FJ-B01)



Scan to know more information

HD-KT-2108

Ceiling: Diamond silver sprayed steel plate with acrylic transparent board (HD-DTA11)
Control panel: Integrated control panel (HD-C12)
Car wall: Mirror-etched stainless steel + modern gray style steel plate (rear wall) modern gray style steel plate + light beige style steel plate (side wall)
Car door: mirror stainless steel
Floor: PVC (FJ-B01)

Passenger Elevator Car Decoration (optional)



FJ-JXA11

Ceiling: Black titanium mirror stainless steel frame, down lamp, top panel LED discolor lighting
Car wall: Stainless steel hairline, black titanium mirror
Handrail: Stainless steel round tube
Floor: Standard PVC(optional marble)



HD-JX12-11

Ceiling: Stainless steel frame in middle, white transparent board on both sides of the soft lighting design, two sides made of stainless steel(HD-DT22)
Operating panel: Integrated operating panel (HD-C12)
Car wall: Two sides made of stainless steel, the middle of the wall mirror etching stainless steel
Car door: Hairline stainless steel
Flooring: PVC (FJ-B18)



FJ-JXA12

Ceiling: Acrylic lighting decoration, stainless steel mirror
Car wall: Stainless steel hairline, stainless steel mirror
Handrail: Stainless steel hairline
Floor: Standard PVC(optional marble)



FJ-JXA13

Ceiling: Acrylic lighting decoration, stainless steel hairline, down lamp
Car wall: Etched mirror, stainless steel hairline
Handrail: Stainless steel flat handrail
Floor: Standard PVC(optional marble)

Passenger Elevator Car Decoration

(optional)



FJ-HD1 

Ceiling: Black titanium mirror stainless steel , Acrylic transparent plate, LED light source
Car wall: Polyvinyl chloride laminated sheet-metal, Mirror stainless steel
Handrail: Black titanium stainless steel luminous handrail
Floor: Gray sintered stone



FJ-HD2 

Ceiling: Frosted stainless steel, Mirror stainless steel
Car wall: Polyvinyl chloride laminated sheet-metal, Mirror stainless steel, Led light source
Floor: Sintered stone (Multiple colors available)

Passenger Elevator Car Decoration

(optional)



HD-JX22-5 

Ceiling: Champagne gold frame with translucent panel (HD-DTA40)
Rear wall: Center Plate Champagne Gold Mirror Etched Stainless Steel, Auxiliary Plate Champagne Gold Mirror Stainless Steel
Side wall: Champagne Gold Mirror Stainless Steel
Front wall: Champagne Gold Mirror Stainless Steel
Car door: Champagne gold mirror stainless steel
Floor: PVC(FJ-B39)-standard, marble/floor tile-optional



HD-JX22-6 

Ceiling: Champagne gold mirror stainless steel, acrylic transparent plate (HD-DTA42)
Back wall: Champagne Gold Sandblasted, Center Mirror Etched
Front wall: Champagne Gold Sandblasted Center with Marbled Palette
Car door: Champagne gold mirror stainless steel
Floor: PVC(FJ-B39)-standard, marble/floor tile-optional



FJ-HD3 

Ceiling: Black titanium mirror stainless steel , White coated steel plate, Led downlight
Car wall: Polyvinyl chloride laminated sheet-metal, Sintered stone (Amazon green), Led light source
Handrail: Black titanium stainless steel luminous handrail
Floor: Gray sintered stone



FJ-HD4 

Ceiling: White coated steel plate, Led downlight
Car wall: Polyvinyl chloride laminated sheet-metal, Sintered stone (Pandora)
Handrail: Black titanium stainless steel luminous handrail
Floor: White sintered stone



HD-JX22-7 

Ceiling: Bronze sandblasted stainless steel frame, hidden light strip, LED linear light (HD-DTA43)
Rear wall: Bronze Mirror Stainless Steel, LED Linear Lights, Bronze Sandblasted Stainless Steel
Side wall: Bronze sandblasted stainless steel
Front wall: Bronze Mirror Stainless Steel
Car door: Bronze mirror stainless steel
Floor: PVC(FJ-B39)-standard, marble/floor tile-optional



HD-JX22-8 

Ceiling: Bronze sandblasted stainless steel frame, hidden light strip, LED linear light (HD-DTA43)
Rear wall: Bronze Mirror Stainless Steel, LED Linear Lights, Bronze Sandblasted Stainless Steel
Side wall: Bronze sandblasted stainless steel
Front wall: Bronze Mirror Stainless Steel
Car door: Bronze mirror stainless steel
Floor: PVC(FJ-B39)-standard, marble/floor tile-optional

Passenger Elevator Car Decoration (optional)



HD-JX22-9 

Ceiling: Bright white decorative ceiling, spotlight, linear light (HD-DTA48)
Back wall: Special-shaped leather grain hard bag, linear light, aluminum profile trim
Side wall: Black titanium mirror stainless steel on both sides, mirror stainless steel in the middle
Front wall: Mirror Stainless Steel
Car door: Mirror stainless steel
Floor: PVC(FJ-B44)-standard, marble/floor tile-optional

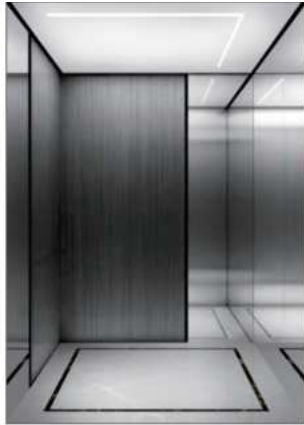

HD-JX22-10 

Ceiling: Painted steel plate, inline wire frame light (HD-DTA49)
Rear wall: Mirror stainless steel, grey vertical stripe art board
Side wall: Mirror stainless steel, grey vertical stripe art board
Front wall: Mirror Stainless Steel
Car door: Mirror Stainless steel
Floor: PVC(FJ-B44)-standard, marble/floor tile-optional

Passenger Elevator Car Decoration (optional)



HD-JX22-13 

Ceiling: Keju wood decorative board, Keju wood decorative line, downlight (HD-DTA45)
Rear wall: Keju wood decorative board, skirting board, auxiliary Keju wood decorative line
Side wall: Keju wood decorative board, skirting board, auxiliary Keju wood decorative line
Front wall: Hairline Stainless Steel
Car door: Hairline stainless steel
Floor: PVC(FJ-B38)-standard, marble/floor tile-optional



HD-JX22-14 

Ceiling: Keju wood decorative board, Keju wood decorative line, downlight (HD-DTA46)
Back wall: Keju wood decorative board, skirting board, auxiliary Keju wood decorative line
Side wall: Keju wood decorative board, skirting board, auxiliary Keju wood decorative line
Front wall: Hairline Stainless Steel
Car door: Hairline stainless steel
Floor: PVC(FJ-B43)-standard



HD-JX22-11 

Ceiling: Acrylic light-transmitting board, simple lamp, mirror stainless steel (HD-DTA54)
Rear wall: Center Black Titanium Mirror Etched Stainless Steel, Secondary Hairline Stainless Steel
Side wall: Center Black Titanium Mirror Etched Plate, Secondary Hairline Stainless Steel
Front wall: Hairline Stainless Steel
Car door: Hairline stainless steel
Floor: PVC(FJ-B44)-standard, marble/floor tile-optional



HD-JX22-12 

Ceiling: Skin-feeling pearlescent ivory, white light strip (HD-DTA39)
Rear wall: Rosewood, grey-brown grill
Side wall: Beige
Front wall: Mirror Stainless Steel
Car door: Mirror stainless steel
Floor: PVC(FJ-B40)-standard, marble/floor tile-optional



HD-JX22-15 

Ceiling: Hairline Stainless Steel Decorative Top, Downlight, Side-Emitting Ring Light (HD-DTA52)
Rear wall: Wood grain makeup board, mirror stainless steel
Side wall: Wood grain makeup board, mirror stainless steel
Front wall: Hairline Stainless Steel
Car door: Hairline stainless steel
Floor: PVC(FJ-B48)-standard



HD-JX22-16 

Ceiling: Ivory white wood veneer frame, gold leaf decorative top plate, titanium mirror stainless steel decorative strips, hidden lights inside the frame (HD-DTA61)
Rear wall: Ebony veneer inlaid titanium mirror stainless steel wire frame
Side wall: Titanium Mirror Stainless Steel
Front wall: Titanium Mirror Stainless Steel
Car door: Titanium mirror stainless steel
Floor: PVC(FJ-B46)-standard, marble/floor tile-optional

Observation Elevator

Not only sightseeing elevator glass steel structure perfect development compact space and whole artistic. Also may act according to the different construction to design, the convenience is quick, all uses the circular generally, the semicircle and the square shape.

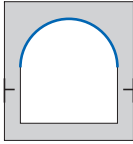

semi-circular shaped

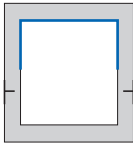

square shaped

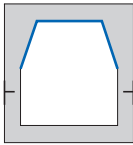

cutting-angle-type

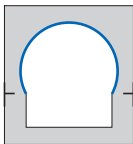

panoramic



FJ-GA01



Upper and lower cover: mirror stainless steel
Sightseeing wall: 6+6 safety laminated glass
Decorative top: mirror stainless steel, acrylic top plate
Car wall: mirror stainless steel
Car door: framed glass door
Handrail: stainless steel single tube
Floor: PVC (FJ-B01)



Scan QR code watch the car



FJ-GA06



Upper and lower cover: Steel plate paint, acrylic decorative strip
Sightseeing wall: Safety laminated glass
Decorative top: Mirror stainless steel, acrylic vault,
Car wall: Hairline stainless steel
Car door: Hairline stainless steel
Handrail: Stainless steel single tube
Floor: PVC (FJ-B23)



Scan QR code watch the car

Observation Elevator Car Decoration (optional)



HD-GA01



Upper and lower cover: Steel plate paint
Sightseeing wall: 180° round safety laminated glass
Decorative top: Steel lacquered frame, acrylic arch roof
Car wall: Hairline stainless steel
Car door: Hairline stainless steel
Handrail: Stainless steel single tube
Floor: PVC (FJ-B01)



Scan QR code watch the car



HD-GA02



Upper and lower cover: Steel plate paint
Sightseeing wall: 180° round safety laminated glass
Decorative top: Steel lacquered frame, acrylic arch top plate, acrylic strip lighting
Car Wall: Hairline Stainless Steel
Car door: Hairline stainless steel
Handrail: Stainless steel double tube
Floor: PVC (FJ-B01)



Scan QR code watch the car



HD-GA03



Upper and lower cover: Mirror stainless steel rib sill, bright red color acrylic decorative cover
Sightseeing wall: 180° round safety laminated glass
Decorative top: Steel plate lacquered top plate frame, middle cream white acrylic lighting
Car Wall: Hairline Stainless Steel
Car door: Hairline stainless steel
Handrail: Stainless steel double tube
Floor: PVC (FJ-B01)



Scan QR code watch the car

Villa Elevator

FUJI GOUP villa elevator adheres to the design idea of environmental protection and energy-saving and merges with the latest elevator technology nowadays in order to ensure safety and reliability of our products. The elegantly designed car, fine and exquisite craft and techniques show the outstanding performance and charm of FUJI GOUP villa elevator.

"The journey scene" matches perfectly with the deluxe and fashionable villa. It is so comfortable and convenient in using FUJI GOUP villa elevator. You will enjoy your noble life as well.

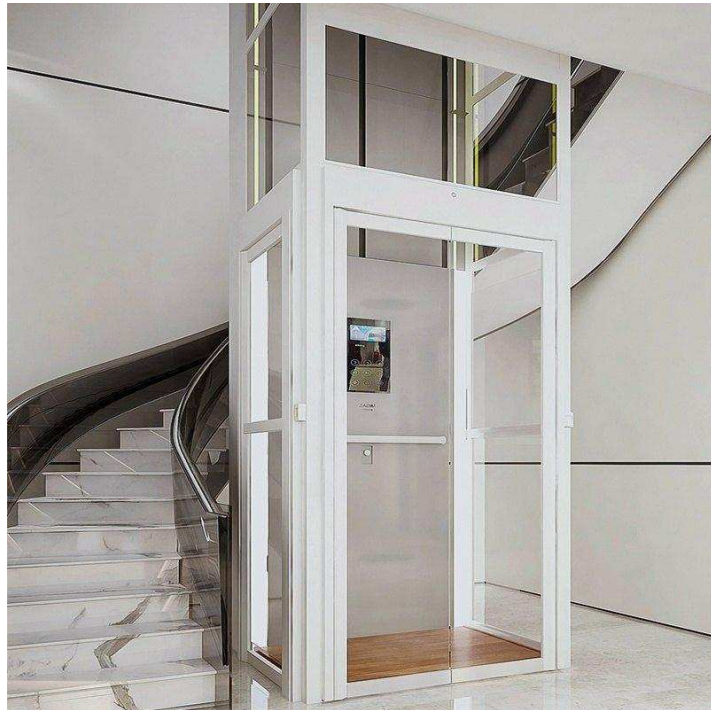

Range of application

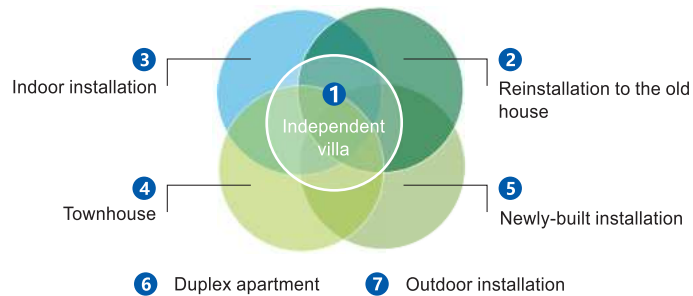

Villa Elevator Car Decoration



HD-BT01 ⤴ (Standard)

Ceiling: Stainless steel, acrylic lighting
Car wall: Hairline stainless steel
Floor: PVC (FJ-B36)



Scan QR code
watch the car



HD-BT05 ⤴ (Optional)

Ceiling: Mirror stainless steel frame, downlight
Car wall: Glass, stainless steel
Floor: PVC (FJ-B21)



Scan QR code
watch the car

Villa Elevator Car Decoration



HD-BT06  (Optional)

Ceiling: Wood frame, middle acrylic
Car wall: Wood grain decoration, glass mirror
Floor: PVC (FJ-B01)



HD-JXA12  (Optional)

Ceiling: Acrylic lighting, mirror stainless steel
Car wall: Hairline stainless steel, mirror stainless steel
Floor: PVC (FJ-B26)



HD-BT-2101  (Optional)

Ceiling: Mirror titanium stainless steel, hidden light strip, LED lighting
Car wall: Combination of wood grain color makeup steel plate and mirror black titanium
Floor: PVC (FJ-B36)

Villa Elevator Car Decoration



HD-BT-2102  (Optional)

Ceiling: Lacquered steel plate, rose gold pattern stainless steel, hidden light strip
Car wall: Three-sided leather hard bag, wood grain finish, rose gold stainless steel and moldings, front wall rose gold stainless steel
Floor: PVC (FJ-B36)



HD-22Z01  (Optional)

Ceiling: Mirror stainless steel, surface mounted lines, downlight (HD-DTA44)
Side wall: Hairline Stainless Steel
Rear wall: Mirror stainless steel, hairline stainless steel, rear wall center split control box (picture HD-COP2104)
Front wall: Hairline Stainless Steel
Floor: PVC (FJ-B49)



HD-22Z02  (Optional)

Ceiling: Black titanium mirror stainless steel decorative strip, hidden light strip, steel spray frame (HD-DTA47)
Side wall: Anthracite Hairline Stainless Steel
Rear wall: Bronze mirror sandblasted (painting is only for illustration)
Front wall: Anthracite Hairline Stainless Steel
Floor: PVC (FJ-B38)



Scan QR code watch the car



Scan QR code watch the car



Scan QR code watch the car



Scan QR code watch the car



Scan QR code watch the car



Scan QR code watch the car



Module segmentation, convenient and efficient

The elevator is mainly consisted of four parts, which are steel structure well, elevator package, connecting platform and exterior decoration. Firstly, pre-modular assembly is carried out in the factory to get sections of modular blocks. At the installation site, the whole installation of products can be finished by the setup and connection of those modular blocks.

Under normal circumstances, the steel structure and the main body of the elevator can be installed in 90 minutes, which can shorten the installation time, can quickly put into use, and has a small influence on the normal life of the community, and is convenient for users.

Green environment, save space

Elevator shaft is made of steel structure with high recovery and utilization rate.

Taishan + series, compared with other series, covering 8% space, for the scene of the space layout and lighting are good. The WR horizontal machine, small tractor wheels, no base design, save the top space.



Way home

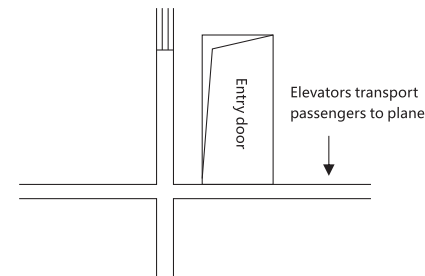

Flat floor into people's homes

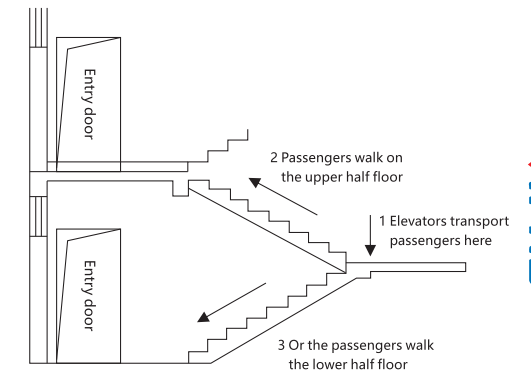

Wrong half layer into people's homes



Scan to know more information

Retrofitting elevator

With the development of modern society, people have higher and higher requirements on the quality of travel.

Many old residential buildings are equipped with no elevator facilities, so that it is very inconvenient for the special crowd, such as elder, pregnant woman and children, go up and down. it is also very easy to cause to cause accident.

In view of this phenomenon, FUJI GROUP elevator developed fast assembling steel structure lift a safe and reliable, convenient installation, beautiful and practical, let the building to upgrade, allowing people to travel quality guaranteed.



Bed Elevator Car Decoration



HD-B02

Optional

Ceiling	Sprayed steel plate, LED lighting
Control Panel	Control Panel (HD-CBZ1)
Car wall	Sprayed steel plate (beige)
Handrail	Stainless steel tube
Floor	PVC (FJ-B01)



HD-B01

Standard

Ceiling	Diamond silver sprayed steel plate with acrylic light-transmitting plate (HD-DTA01)
Control Panel	Integrated Control Panel (HD-C12)
Car wall	Hairline stainless steel
Handrail	Stainless steel flat handrail
Floor	PVC (FJ-B01)



Bed Elevator

Bed elevator often competes with time in vast hospitals, modern medical treatment centers, sanatoriums, medi-care centers etc. where healing the wounded and rescuing the dying are the bounden duties. FUJI GROUP bed elevator series adhere to the persistently humane thinking, apply fuzzy logic and group supervision technology from expert system, fulfill the intellectual elevator travel and reduce the patients' waiting period to minimum extent.





Freight Elevator

FUJI GOUP series freight elevator, using the advanced permanent magnet synchronous gearless traction technology, reasonable design, without room; the traction machine has the advantage of light weight, small volume, saving the architectural space, greatly improve the performance and quality of machine room less elevator, reduce energy consumption, the failure rate.

FUJI GOUP series MRL freight elevator with less shaft height, reduce the design height of the factories and other buildings, can meet the actual needs of the enterprise. To be the best choice for the transportation of goods, such as factories, warehouses, department stores, property centers, libraries and so on.

Car Elevator

With economic development, people's living quality is keeping to improve, the car gradually into the homes of ordinary families. FUJI GROUP series car elevator, make full use of FUJI GROUP years car elevator technology, combined with the domestic market and the development of the machine room car elevator and machine roomless car elevator.

FUJI GROUP machine room car elevator sare using the latest VVVF technology dedicated to the transport car elevator and overall elevator system to improve floor less restricted, and ensure the millimeter accurate flat layer, comfortable, low noise, technology innovation, further reducing the energy consumption of more than 30%.

FUJI GROUP machine roomless car elevator are using machine roomless configuration, under special circumstances provides a flexible solution for designers. The intelligent microcomputer control system, high strength and strong design, avoided by car to uneven traction system load increase and produce noise and capsules jitter, make the discrepancy of the car more safe. Car elevator is widely used in the parking lot, garage, underground garage and other places.

Freight Elevator Car Decoration



HD-H02

Optional

Ceiling	Hairline stainless steel
Car wall	Hairline stainless steel
Car door	Hairline stainless steel
Lighting	LED lamp
Open door type	Center split bi-fold
Floor	Checked steel plate



HD-H01

Standard

Ceiling	Painted steel
Car wall	Painted steel
Car door	Painted steel
Lighting	LED lamp
Open door type	Side opening
Floor	Checked steel plate



Freight Elevator Decoration

Hall door Series



Center opening

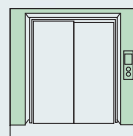

Side opening

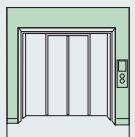

Double-folded center opening type

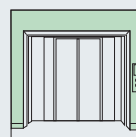

3-folded center opening type

Control operation panel and hall buttons

Simple and elegant buttons handling facility, matching the diversified and personalized cabin to a greater extent.



HD-H01C

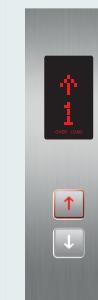

HD-H01X

Floor optional

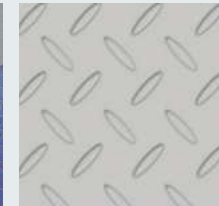

HD-HDB01
Checked steel plate

Crash barrier elevator



Wooden



Black rubber

The pictures are plotted by computer and are likely somewhat different from the actual products.

Integrated control box

FHSP50

HENGYUN series lift (Standard)



HD-C12

FJ-X20A

HD-XBZ5A

No bottom box calling
Anti-fingerprint stainless steel

Split operating panel

FHSP50

HENGYUN series lift (Optional)



HD-CBZ5A

HD-XBZ5A

HD-CBZ1

HD-XBZ1

No bottom box calling

No bottom box calling

Integrated control box

FHSP30

HENGAN series lift (Standard)



HD-C12

HD-X06B

No bottom box calling

Multimedia display of COP (Optional)



FFA-YD360-7D

FFA-YD360-8D

FFA-YD360-104D

Suspension operation panel for disabled

HD-C04



Handrail series

FJ-FS01

FJ-FS02

FJ-FS04

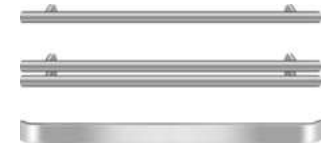

Optional colors

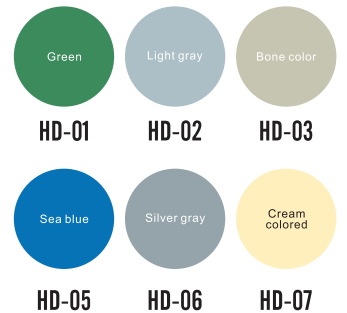

HD-04

HD-05

HD-06

HD-07

Passenger Elevator Operation Panel Series(optional)



FJ-C01



FJ-X01A
No bottom box calling (simplex)



FJ-C02



FJ-X02B
Hall call box (duplex)

» Direction lantern



FJ-DL01



FJ-DL02



FJ-DL03



FJ-DL04

» Hall indicator



FJ-X02A

Hall call box (simplex)



FJ-LCDA

» Hall call box (no indicator)



FJ-LCDB



FJ-C03

» Optional C.O.P.LCD



FJ-X03A



FJ-X03B



FJ-C06



Hall call box(simplex)

FJ-X06A



Hall call box(duplex)

FJ-X06B

• Material: Titanium gold stainless steel mirror

• Material: Blak Titanium-gold

Passenger Elevator Ceiling Series

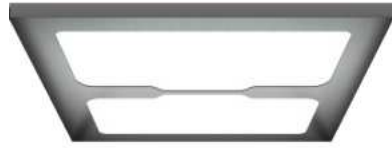

HD-DTA01

Diamond silver painted steel with acrylic photic board.



HD-DTA02

Mirror stainless steel framework, acrylic arched top plate, LED light



HD-DTA03

Stainless steel mirror base-plate is supplemented by rectangle hollow transparent pole. The soft lighting design of arched white light-passing board is in the middle part



HD-DTA04

Mirror stainless steel framework, acrylic arched top plate, intermediate down lamp decoration



HD-DTA05

Mirror stainless steel framework, acrylic arch paint-jet top plate in middle acrylic lighting decoration on both sides



HD-DTA06

Stainless Steel Mirror finish framework with acrylic arched paint-jet top plate in middle with acrylic lighting decoration on both sides



HD-DTA07

Hairline stainless steel, Vaulted light board with acrylic



HD-DTA08

Painted steel plate, stainless steel hairline, return light



HD-DTA09

Acrylic transparent panel with metallic paint



HD-DTA10

Black titanium mirror stainless steel frame, down lamp, top panel LED discolor lighting



HD-DTA11

Acrylic lighting decoration, stainless steel mirror



HD-DTA12

Acrylic lighting decoration, stainless steel hairline, down lamp



HD-DT01

Steel plate plastic jetting frame with acrylic lighting Cover. Intermediate circular translucent lighting is used.



HD-DT04

Stainless steel mirror base-plate is supplemented by rectangle hollow transparent pole. The soft lighting design of arched white light-passing board is in the middle part



HD-DT07

Stainless steel mirror hollow plate and white organic board, with stainless steel frame



HD-DT08

Video vault in the middle, on both sides of the stainless steel floor with leds light lighting design



HD-DT09

Mirror frame, supplemented by leds on mirror stainless steel plate, the middle section is arched white plate light lighting design



HD-DT10

Stainless steel mirror base-plate is supplemented by rectangle hollow transparent pole. The soft lighting design of arched white light-passing board is in the middle part



HD-DT11

Mirror frame, supplemented by leds on mirror stainless steel plate, the middle section is arched white plate light lighting design

Passenger Elevator Landing Door Series (optional)



FJ-MA01

Mirror, etched
(optional Titanium gold mirror, etched)

FJ-MA02

Mirror, etched, Stainless steel
(optional Titanium gold mirror, etched)

FJ-MA03

Mirror, etched, Stainless steel
(optional Titanium gold mirror, etched)



FJ-MA07

Mirror, etched, Titanium gold
(optional stainless steel mirror, etched)

FJ-MA08

Titanium gold, Mirror, etched,
Stainless steel, And grain
(optional stainless steel mirror, etched)

HD-M01

Mirror, etched, Stainless steel



FJ-MA04

Titanium gold, etched,
(optional stainless steel mirror, etched)

FJ-MA05

Mirror, etched, rose gold
(optional stainless steel mirror, etched)

FJ-MA06

Mirror, etched, rose gold
(optional stainless steel mirror, etched)



HD-M02

Mirror, etched, Stainless steel, Golden recess

HD-M03

Mirror, etched

HD-M04

Mirror, etched, Spraying

Passenger Elevator Floor Decoration PVC (optional marble)

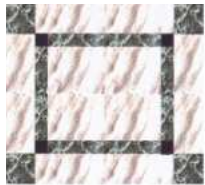

FJ-B01(PVC)
FJ-B01D(Marble)

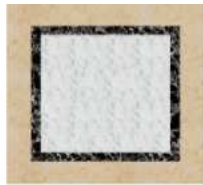

FJ-B02(PVC)
FJ-B02D(Marble)

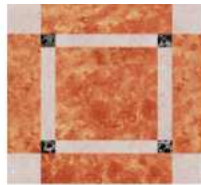

FJ-B03(PVC)
FJ-B03D(Marble)



FJ-B04(PVC)
FJ-B04D(Marble)

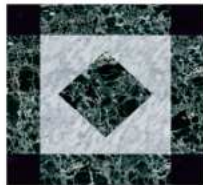

FJ-B05(PVC)
FJ-B05D(Marble)



FJ-B06(PVC)
FJ-B06D(Marble)



FJ-B07(PVC)
FJ-B07D(Marble)



FJ-B10(PVC)
FJ-B10D(Marble)



FJ-B11(PVC)
FJ-B11D(Marble)



FJ-BS1(Sintered stone)



FJ-BS2(Sintered stone)



FJ-BS3(Sintered stone)

Passenger Elevator Handrail Series (optional)



FJ-FS01



FJ-FS02



FJ-FS03



FJ-FS04



HD-F03

FJ-FS01:Stainless steel handrail

FJ-FS02:Chromed steel base,central material is acrylic crystal handrail

FJ-FS03:Titanium-gold and stainless steel handrail base,central material is solid wood

FJ-FS04:Stainless steel flat handrail

HD-F03:Triple combination mirror stainless steel tube

Optical colors

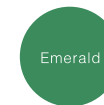

Emerald

HD-01



Light gray

HD-02



Bone

HD-03



Apple green

HD-04



Sea blue

HD-05



Silver gray

HD-06

Note: There might be slight difference between the samples and real products, please take the real products as criterion.

Passenger Elevator Function

Standard Function

Full collective control	Controller Will Automatically Select The Nearest Elevator Responding Passenger's Call.
Inspection operation	Automatically Move To The Nearest Leveling In A Slow Speed.
Automatic backplane	In normal condition The Elevator will automatically move to the nearest leveling in a slow speed.
Automatic door opening	Elevator open the door automatically.
Automatic door opening time adjustment	Door remaining open for a short time in normal condition.
Door opening button(external)	Door remaining open when the door opening button was pushed on.
Door pre closing function	To make door close immediately in normal opening condition.
Door opening button(internal)	To make door open or re open when elevator stops.
Full load bypass	When the elevator is fully loaded, it will travel to destination without responding to calling outside.
Automatic turn off lighting and fan	Lighting and fan will cut off power automatically without any call or indication in 3 minutes.
Automatic return to home landing	In normal condition ,the elevator will return to home landing without any more calls or indications.
Door re closing	The door will try to close again when it is blocked.
Error recording	Mainboard can record 10 errors at most.
Hoistway self learning	Elevator can learn the data and situation automatically before using.
Attendant service	The lift is close by continued pressing close buttons.
Bypass operation	Elevator will travel directly to destination without stopping.
Automatic correction of floor position signal	Self correcting the data when the elevator reach final limit switch.
Lift locking	Lock the elevator and turn off the power so that no one can use it.
Protection of door lockup outside door area	No door opening when it is not in leveling position.
Infrared light curtain protection	Door will opening when it is blocked.
Over load protection	Elevator refuse to travel with buzz when it is overloaded.
Reversal running protection	When the running direction is different with destination direction ,it stops automatically.
Anti skip protection	Travelling a long time without door opening ,it will stop automatically.
Anti terminal over running protection	Security risks are prevented by preventing the continued operation of the failure of the terminal switch.
Phase protection	Stop to move when the final limit switch fails to have function.
Phase protection	The elevator will stop with wrong phase or lack phase.
Contact protection	Stop running when safety devices conflict.
Failure analysis of shaft self learn	When the shaft learned by itself that it doesn't finish it correctly.
Motor temperature protection	Protect the motor from being over heat.

Standard Function

Door opening failure protection	Stop running when error happens to door.
Protection for door lock short circuit	Elevator refuse to move when error suddenly happens to the brake.
Door lock failure for brake switches	Elevator will stop at once when error suddenly happens to door lock.
Over speed protection	In case of elevator running too fast.
Contact protection for brake switches	Protect the elevator when error happens to the brake.
Five - party interphone communication	Communication for machineroom , car top , car cage, pit and inspection station.
Wheeling protection	Safety protection in rescuing.
Alarm bell	When the anomaly occurred, passenger in the cabin can notice the outside with this device.
Emergency lighting	When the power supply is failure , it can provide the lighting of the car.
Two doors operator	Only for opening through door opening type.
Level switch protection	It is a safety protection in case of the trouble in leveling switch.
False call canceling	When the passengers press the false button. it can cancel the call through the two times press.
Automatic reversal call canceling	When the running direction is different with destination direction .it stops automatically.
Floor display directional setup	Directional setup of service floor.
Isolate running	Operation similar to attendant service function.
Segment code or dot matrix floor indicator	The indicator displayed in matrix type.
Rolling display of running direction	The running direction display in a rolling way.
Forced door closing	The door nudging device will force the door closing when it open too long .
CAN communication protection	Prevent the danger in case of trouble.
Arrival gong	Sound to indicate leveling is finished.
Emergency return in case of fire	The elevator will return to home floor in a short time when fire emergency happens.
Main control protection	Stop the running of the elevator in case of trouble.
Main control CPU WDT protection	When test the trouble of CPU,WDT make it reset.
Discretionary setup of service floor	Using the operator to setup the landing floor discretionally.
Test running	It is used for testing the new elevator.
Clock control	It can record the time of trouble ,and decide to stop at any floor.
Direct landing	The efficiency of the elevator can be improved by the distance principle to deceleration.
Load weighing device	With such system,the elevator can self learn the data to improved the start up.
Parallel control	Two elevator through the CAN serial communication bus to coordinate the call.
Protection device for accidental movement of the car	In case of accidental movement that the car leaves the landing floor while the landing door is unlocked as well as the car door keeps open, protection device to prevent or stop such movement should be equipped.
Bypass protection	Bypass protection provides safety protection for daily maintenance.

Freight Elevator Function

Machine Roomless Passenger Elevator Construction Layout Drawing

Standard Function

IC card management	Users can control the certain floors with this card.
Voice announcer	Voice announcement for running situation.
Automatic rescue device(ARD)	The elevator will automatically run to the nearest door zone when the power supply fails.
Advance door opening	In process of leveling, the distance is right, and the speed is little than the regulated one, the door will open in advance.
Arrival forecasting light	Flashing when the elevator is leveling, to remind the passenger that it will landing.
Arrival chime	It can ring when the elevator is landing.
Remote monitoring	It can monitoring the running situation of elevator.
Earthquake shutdown function	When the earthquake device is moving, the elevator will landing at the nearest floor , and open the door.
Fireman operation	Firemen can use this elevator to travel to destination without responding to calling outside.
Self re leveling	When the leveling is not accurate, it will re leveling automatically.
Sub control panel	It just like the main accurate, it will re leveling automatically.
Rear car operational panel	It control the rear opening and close.
The handicapped car operational panel	It specially desinged for the handicapped people.
Group control	Through the group control to coordinate the running of many elevator.
The service for the rush hour of go to work	Only for group control, when the elevator runs up from home floor with 3more instructions, and other elevator in response to instructions and calls will automatically return to home floor and open doors
The service for the rush hour of off work	Only for group control, when the elevator runs comes down from home floor with 3more instructions, and other elevator in response to instructions and calls will automatically return to home floor and open doors.
Dispersed waiting	Only for group control, when the elevator stops running in a specified time, the elevator will return to the pre setting floor to shorten the call time for various floors to improve efficiency
Isolated control of front and rear door	There are two kinds: one is the rear car operational board, the other is the call box outside the rear door.
Anti nuisance operation	It can cancel the disturbance instruction.
VIP service	It can cancel all the instruction and call until the VIP arrives the certain stop without any other stop.
Door remaining open function	Keep press the door open button to delay of door closing.
LCD indicator	It can clearly indicate the floors and other information.

Shaft elevation

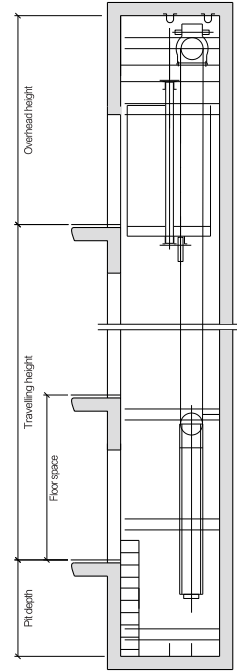

Overhead floor layout drawing

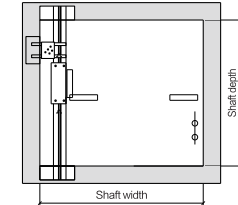

Shaft layout drawing

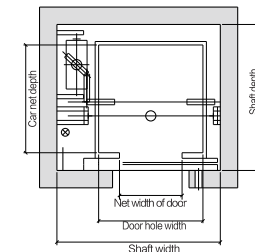

Machine roomless passenger specifications

Persons	Rated capacity (kg)	Rated speed (m/s)	Net size of car (mm)	Net size of door D.W x D.H (mm)	Shaft size (mm)		
			C.W x C.D x D.H	2P Central opening	H.W x H.D	HR.H	PIT
6	450	1.0	1100x1100x2300	800x2100	2050x1850	4200	1500
		1.5/1.75				4200	1500
8	630	1.0	1400x1100x2300	800x2100	2250x1900	4400	1600
		1.5/1.75				4200	1500
		2.0				4400	1600
		2.5				4800	1800
10	800	1.0	1400x1350x2300	800x2100	2250x1950	4200	1500
		1.5/1.75				4400	1600
		2.0				4800	1800
		2.5				2000	
13	1000	1.0	1500x1550x2300	900x2100	2350x2150	4200	1500
		1.5/1.75				4400	1600
		2.0				4800	1800
		2.5				4800	2000
21	1600	1.0	1900x1800x2300	1100x2100	2850x2400	4500	1500
		1.5/1.75				4700	1600
		2.0				4900	1800
		2.5				5100	2000
26	2000	1.0	1900x2200x2300	1100x2100	2900x2600	4500	1500
		1.5/1.75				4700	1600
		2.0				4900	1800
		2.5				4900	1800

Note: Only for reference, final manufacture please follow contract.

Small Machine Room Elevator Construction Layout Drawing

Shaft elevation

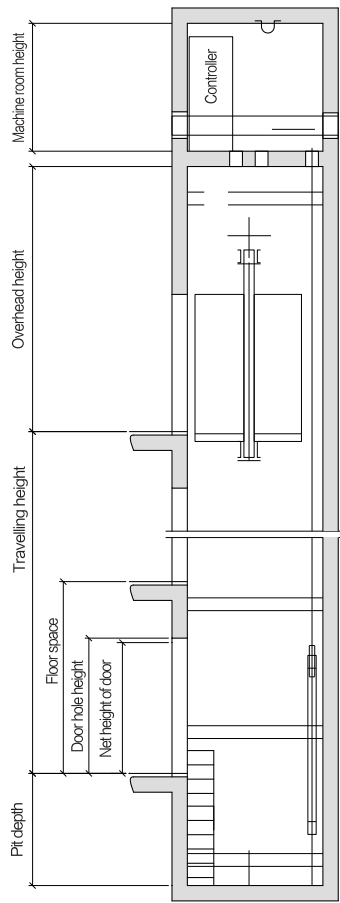

Machine room layout drawing

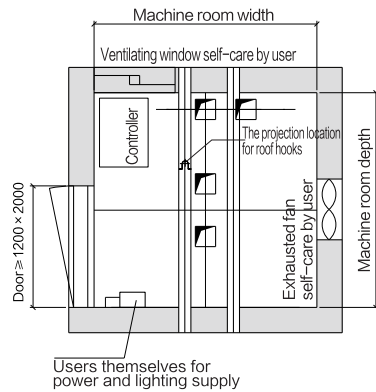

Shaft layout drawing

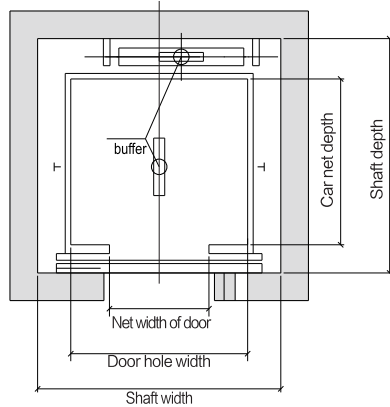

Small machine room passenger specifications

Persons	Rated capacity (kg)	Rated speed (m/s)	Net size of car (mm)	Net size of door D.W x D.H (mm)	Shaft size (mm)			Machine room size (mm)	
			C.W x C.D x D.H	2P Central opening	H.W x H.D	HR.H	PIT	MR.W x MR.D	MR.H
6	450	1.0	1400x850x2300	800x2100	2000x1800	4000	1500	2000x1800	2500
		1.5/1.75				4400			
8	630	1.0	1400x1100x2300	800x2100	2000x2050	4200	1500	2000x2050	2500
		1.5/1.75				4400	1600		
10	800	1.0	1400x1350x2300	800x2100	2000x2300	4200	1500	2000x2300	2500
		1.5/1.75				4400	1600		
		2.0				4800	1800		
		2.5				4800	2000		
		4.0				4200	1500		
13	1000 (1050)	1.0	1600x1450x2300 1100x2300x2300 (Residence / stretcher elevator)	900x2100	2200x2400 2050x2850 (Residence / stretcher elevator)	4200	1500	2200x2400 2050x2850 (Residence / stretcher elevator)	2500
		1.5/1.75				4400	1600		
		2.0				4800	1800		
		2.5				5200	2600		
		3.0				5500	3100		
		3.5				6000	3850		
		4.0				4200	1500		
16	1250	1.0	1900x1450x2300	1100x2100	2500x2400	4200	1500	2500x2400	2500
		1.5/1.75				4400	1600		
		2.0				4800	1800		
		2.5				5200	2600		
		3.0				5500	3100		
		4.0				6000	3850		
18	1350	1.0	1900x1550x2300	1100x2100	2500x2500	4200	1500	2500x2500	2500
		1.5/1.75				4500	1600		
		2.0				4800	1800		
		2.5				5200	2600		
		3.0				5500	3100		
		3.5				6000	3850		
		4.0				4200	1500		
21	1600	1.0	1900x1800x2300	1100x2100	2500x2800	4200	1500	2500x2800	2500
		1.5/1.75				4500	1600		
		2.0				4800	1800		
		2.5				5200	2600		
		3.0				5500	3100		
		3.5				6000	4000		
		4.0				6350	5000		
		6.0				4200	1500		
10.0	4500	1600							
26	2000	1.0	1900x1800x2300	1100x2100	2700x2900	6350	5000	4200x2900	2500
		1.5/1.75	1900x1800x2800	1100x2100	2800x3000	8800	7200	4300x3000	3800
26	2000	1.0	1900x2200x2300	1100x2100	2700x2800	4500	1500	2700x2800	2500
		1.5/1.75				4700	1600		
		2.0				5000	1800		
		4.0				6000	3850		
		6.0				6400	4000		
		8.0				7500	6000		
		10.0				8800	7200		

Note: Only for reference, final manufacture please follow contract.

Semicircle Observation Elevator Construction Layout Drawing

Square Observation Elevator Construction Layout Drawing

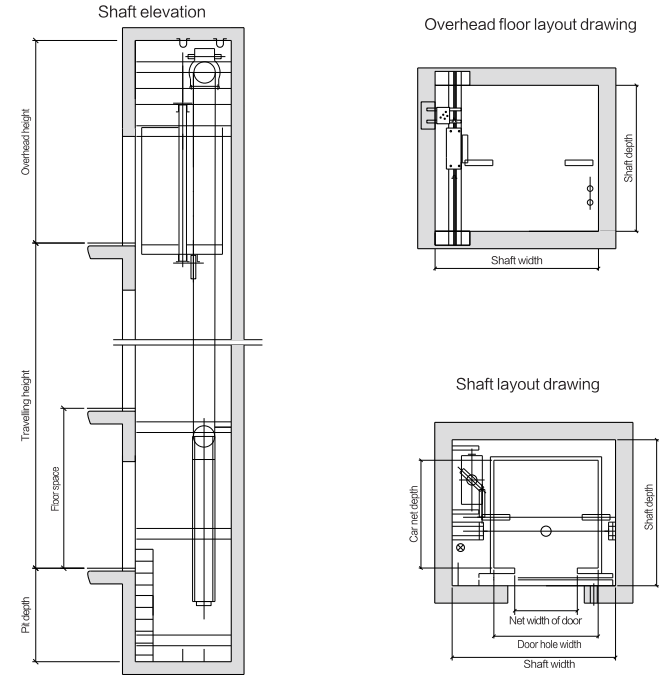
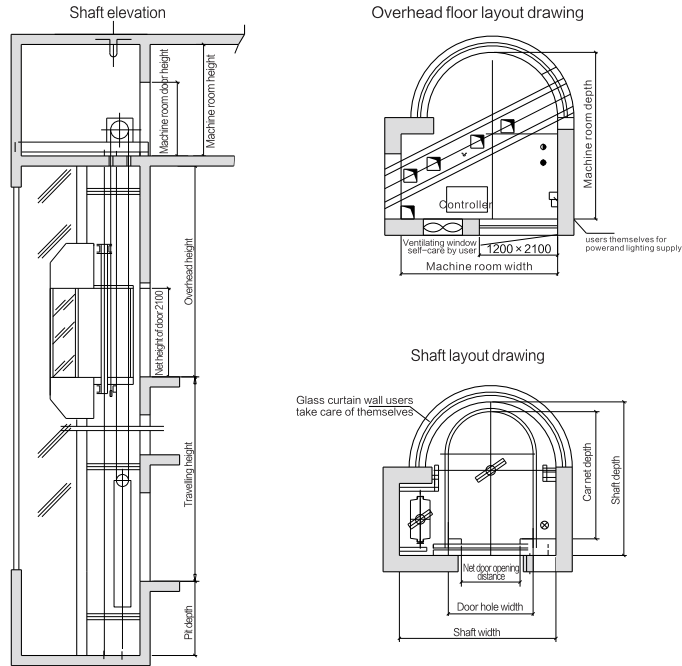

Semicircle machine room / Machine roomless elevator specifications

Persons	Rated capacity (kg)	Rated speed (m/s)	Net size of car (mm)		Shaft size (mm)			Machine room size (mm)	
			C.W x C.D x D.H	2P Central opening	H.W x H.D	HR.H	PIT	MR.W x MR.D	MR.H
8	630	1.0	1100x1600x2300	700x2100	2200x2185	4500	1500	2200x2185	2500
		1.5/1.75				4700	1600		
10	800	1.0	1200x1800x2300	800x2100	2300x2355	4500	1500	2300x2355	2500
		1.5/1.75				4700	1600		
		2.0				4900	1800		
		2.5				5100	2000		
		4.0				6000	3850		
13	1000	1.0	1300x1950x2300	900x2100	2400x2535	4500	1500	2400x2535	2500
		1.5/1.75				4700	1600		
		2.0				4900	1800		
		2.5				5100	2000		
		4.0				6000	3850		
16	1250	1.0	1400x2150x2300	900x2100	2500x2600	4500	1500	2500x2600	2500
		1.5/1.75				4700	1600		
		2.0				4900	1800		
		2.5				5100	2000		
		4.0				6000	3850		
18	1350	1.0	1500x2150x2300	1000x2100	2600x2600	4500	1500	2600x2600	2500
		1.5/1.75				4700	1600		
		2.0				4900	1800		
		2.5				5100	2000		
		4.0				6000	3850		
21	1600	1.0	1500x2450x2300	1000x2100	2600x2900	4500	1500	2600x2900	2500
		1.5/1.75				4700	1600		
		2.0				4900	1800		
		2.5				5100	2000		
		3.0				5200	2600		
		4.0				6000	3850		
26	2000	1.0	1700x2600x2300	1100x2100	2800x3050	4500	1500	2800x3050	2500
		1.5/1.75				4700	1600		
		2.0				4900	1800		
		3.0				5200	2600		
		4.0				6000	3850		

Note: Only for reference, final manufacture please follow contract.

Square machine room / Machine roomless elevator specifications

Persons	Rated capacity (kg)	Rated speed (m/s)	Net size of car (mm)		Shaft size (mm)			Machine room size (mm)	
			C.W x C.D x D.H	2P Central opening	H.W x H.D	HR.H	PIT	MR.W x MR.D	MR.H
6	450	1.0	1100x1100x2300	800x2100	2050x1850	4200	1500		
8	630	1.0	1400x1100x2300	800x2100	2250x1900	4200	1500	/	/
		1.5/1.75				4400	1600		
10	800	1.0	1400x1350x2300	800x2100	2250x1950	4200	1500	/	/
		1.5/1.75				4400	1600		
		2.0				4800	2000		
		2.5				4800	2000		
		4.0				6000	3850		
13	1000	1.0	1500x1550x2300	900x2100	2350x2150	4200	1500	/	/
		1.5/1.75				4400	1600		
		2.0				4800	1800		
		2.5				4800	2000		
		4.0				6000	3850		
21	1600	1.0	1900x1800x2300	1100x2100	2850x2400	4500	1500	/	/
		1.5/1.75				4700	1600		
		2.0				4900	1800		
		2.5				5100	2000		
26	2000	1.0	1900x2200x2300	1100x2100	2900x2600	4500	1500	/	/
		1.5/1.75				4700	1600		
		2.0				4900	1800		
		3.0				5200	2600		
		4.0				6000	3850		

Note: Only for reference, final manufacture please follow contract.

Villa Elevator Construction Layout Drawing

Steel Structure Elevator Construction Layout Drawing

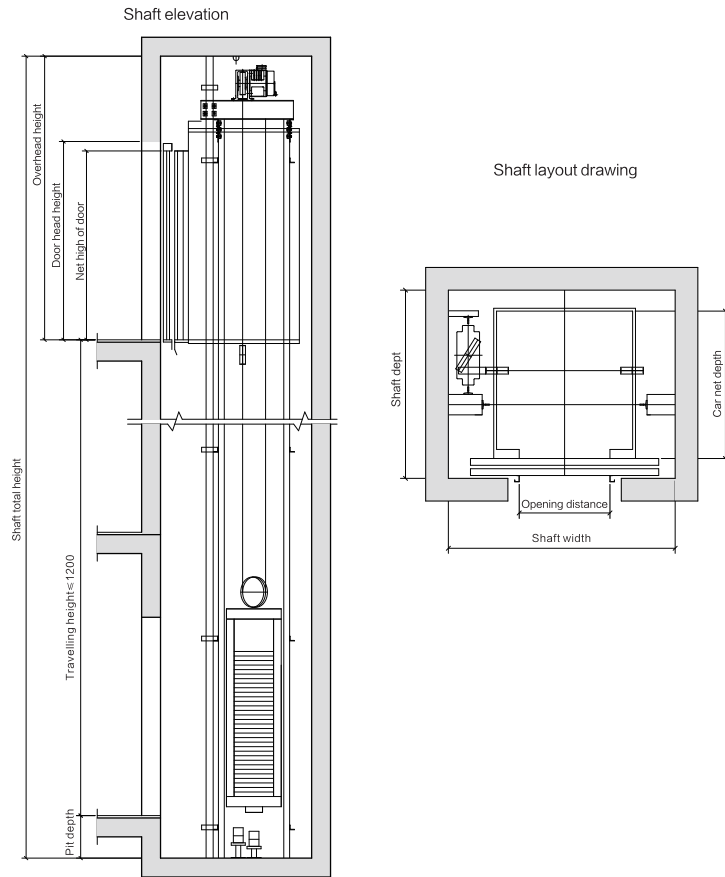

Villa elevator specifications

Persons	Rated capacity (kg)	Rated speed (m/s)	Net size of car (mm)	Net size of door D.W x D.H (mm)	Shaft size (mm)		
			C.W x C.D x D.H	2P Central opening	H.W x H.D	HR.H	PIT
3	260	0.4	800x1150x2200	700x2000 Side door	1400x1500	3500	800
4	320	0.4	950x1300x2200	700x2000	1600x1600	3500	800
5	400	0.4	1200x1300x2200	800x2000	1850x1600	3500	800

Note: Only for reference, final manufacture please follow contract.

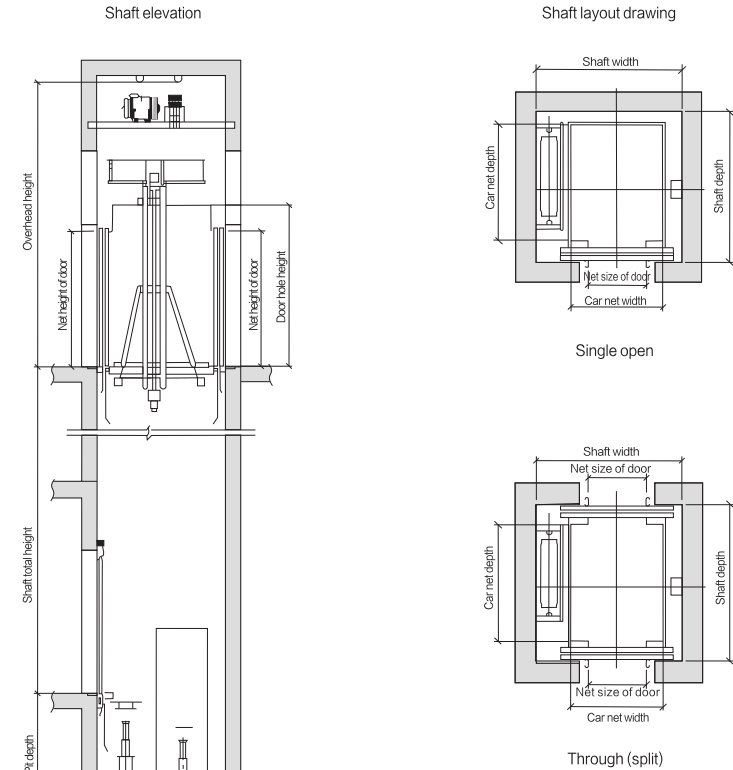

Steel structure elevator specifications

Persons	Rated capacity (kg)	Rated speed (m/s)	Net size of car (mm)	Net size of door (mm)		Shaft size (mm)				
			CW x CD x CH	OP	OPH	HW	HD (Single open)	HD Through (split)	K	S
6	450	1.0	1000x1300x2400	650x2100	1650	1700	1800	4500	1400	
		1.5						4600	1500	
8	630	1.0	1100x1400x2400	700x2100	1750	1800	1900	4500	1400	
		1.5						4600	1500	
10	800	1.0	1350x1400x2400	800x2100	2000	1800	1900	4500	1400	
		1.5						4600	1500	
13	1000	1.0	1500x1550x2400	900x2100	2150	1950	2050	4500	1400	
		1.5						4600	1500	

Note: Only for reference, final manufacture please follow contract.

Bed Elevator Construction Layout Drawing

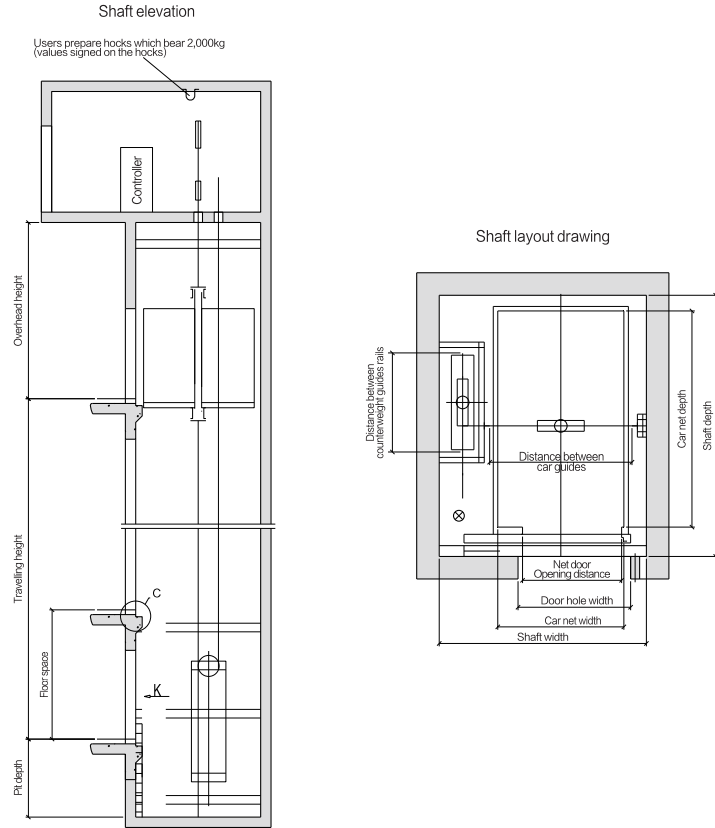

Freight Elevator Construction Layout Drawing

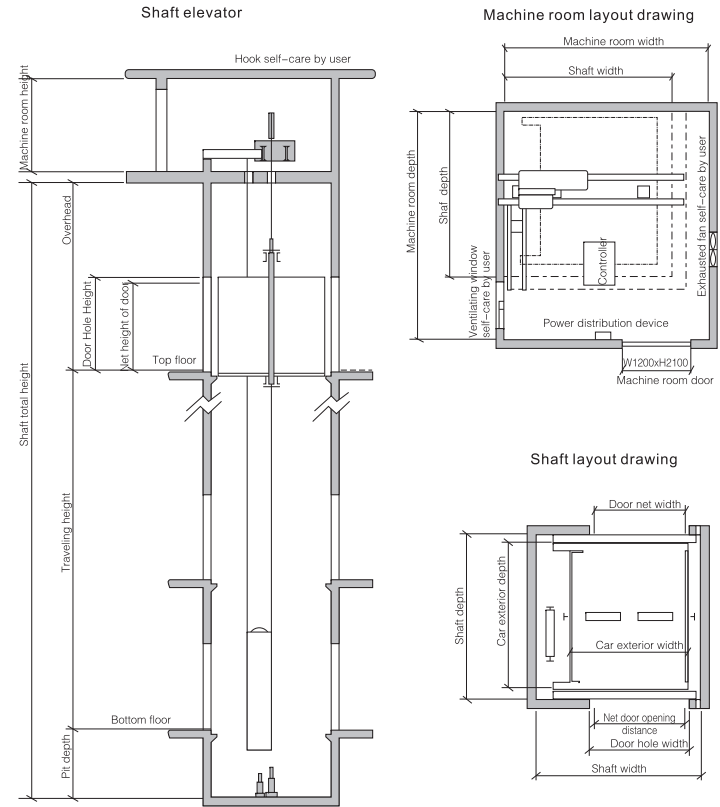

Freight elevator specifications

Load (kg)	Speed (m/s)	Exterior size of car width x depth x height (mm)	Net door opening width (mm)	Shaft Net Size			Machine Room Net Size		Door Open type
				width x depth (mm)	Overhead height	Pit depth	width x depth (mm)	height (mm)	
630	0.5	1200x1500x2200	1100x2100	2100x1860	4200	1500	2500x3000	2200	Two panel side opening
1000	0.5	1500x1800x2200	1200x2100	2250x2160	4200	1500	3000x3000	2200	Two panel side opening
2000	0.5	1570x2900x2200	1500x2100	2700x3260	4200	1500	3500x3000	2500	Two panel side opening
	1.0	4500			1500				
	1.5	2000x2300x2200			4500	1600			
3000	2.0	2070x3050x2200	1800x2100	3300x3410	4500	1500	3800x4200	2500	Four panel center opening
	0.5				4800	1800			
3200	1.0	2070x3100x2200	1800x2100	3300x3460	4500	1500	3800x4200	2500	Four panel center opening
5000	0.25	2800x3400x2500	2000x2200	4200x3800	5000	1600	4200x3800	2800	Four panel center opening
	0.5								
7000	0.25	3000x4200x2500	2600x2400	4500x4600	5000	1600	4500x4600	2800	Four panel center opening
	0.5								
10000	0.25	3070x5760x2500	2600x2400	4900x6200	5000	1600	4900x6200	2800	Four panel center opening

Machine room / Machine roomless bed elevator specifications

Persons	Rated capacity (kg)	Rated speed (m/s)	Net size of car (mm)		Shaft size (mm)			Machine room size (mm)			
			C.W x C.D x D.H	D.W x D.H	H.W x H.D	HR.H	PIT	MR.W x MR.D	MR.H		
21	1600	1.0	1400x2400x2300	1100x2100	2550x2900	4500	1500	2550x2900	2500		
		1.5/1.75								4700	1600
		2.0								4900	1800
		2.5								5100	2000
		1.0								4500	1500
24	1800	1.5/1.75	1600x2400x2300	1200x2100	2750x2900	4700	1600	2750x2900	2500		
		2.0								4900	1800
		1.0								4500	1500
26	2000	1.0	1700x2400x2300	1200x2100	2850x2900	4700	1600	2850x2900	2500		
		1.5/1.75								4900	1800
		2.0								4900	1800

Note: Only for reference, final manufacture please follow contract.

Note: Only for reference, final manufacture please follow contract.

Machine Roomless (MRL) Freight Elevator Construction Layout Drawing

Car Elevator Construction Layout Drawing

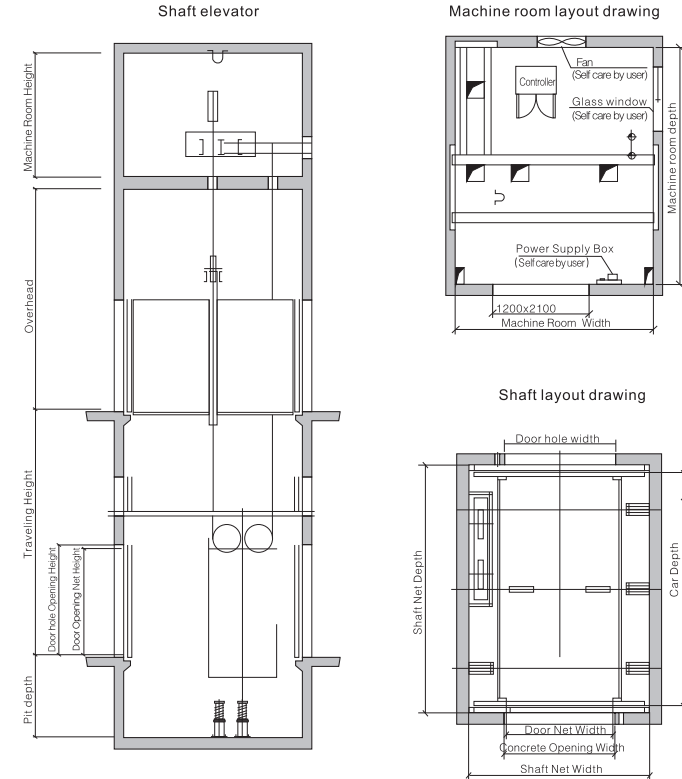
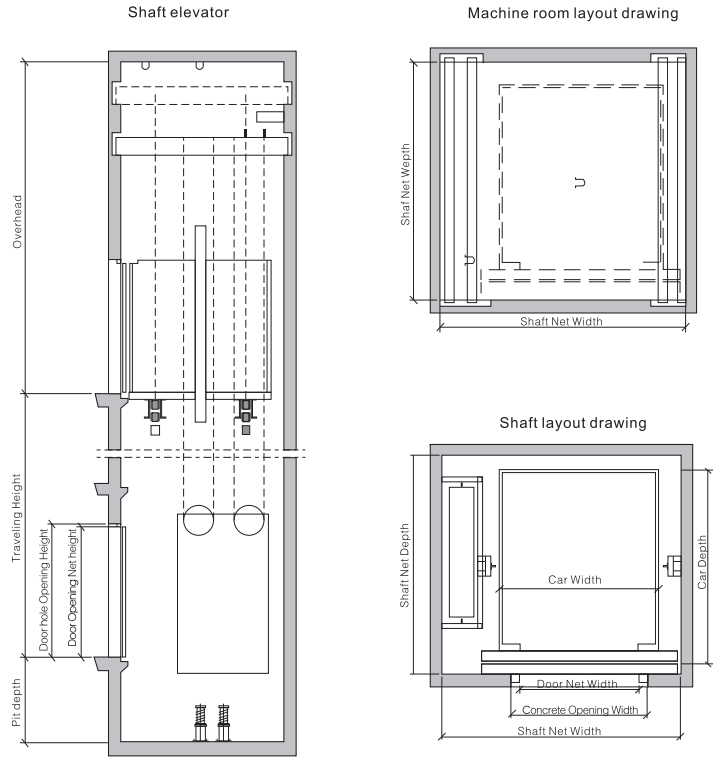

Machine roomless(MRL) freight elevator specifications

Load (kg)	Speed (m/s)	Exterior size of car width x depth x height (mm)	Net door opening width x height (mm)	Shaft Net Size			Door Open type
				width x depth (mm)	Overhead height	Pit depth	
1000	0.5	1500x1800x2200	1200x2100	2250x2200	4500	1500	Two panel side opening
	1.0				4500	1500	
	1.5				4600	1600	
	2.0				4800	1800	
2000	0.5	2000x2300x2200	1500x2100	3150x2660	4800	1500	Two panel side opening
	1.0				5000	1500	
	1.5				5200	1600	
	2.0				5200	1800	
3000	0.5	2470x2560x2200	1800x2100	3700x3000	5000	1600	Four panel center opening
5000	0.5	2800x3400x2500	2400x2400	4250x3800	6100	1600	Four panel center opening

Note: Only for reference, final manufacture please follow contract.

Car elevator specifications

Load (kg)	Speed (m/s)	Door open type	Net door opening width x height (mm)	Exterior size of car width x depth (mm)	Shaft Net Size (mm)			Machine Room Net Size (mm)
					width x depth	Pit depth	Overhead height	width x depth x height
3000	0.25/0.5	Four Panel Center Opening	2400 x 2200	2700 x 5800	4100 x 6160	1600	4800	4100 x 6160 x 2500
5000	0.25/0.5	Four Panel Center Opening	2600 x 2200	3500 x 7200	4750 x 7560			4750 x 7560 x 2500

Note: Only for reference, final manufacture please follow contract.

Escalator Moving walk



Aspirations for the future

The exterior design combines modern aesthetic concepts with a variety of handrails and wall panels. The dynamic streamlined shape gives the city a smart rhythm, adding a beautiful landscape to the city's public buildings such as shopping malls, supermarkets and overpasses.



Luxury temperament



The beauty of precision structure



Efficient and safe beauty



The beauty of technology sensing



© Luxury temperament

Reinforced glass siding, luxurious decoration is superior.

© The beauty of precision structure

High-strength metal structure, Build precision dimensions, Super-conscious aesthetic design, perfect blend with the building.

© Efficient and safe beauty

With a faulty display, It can accurately analyze the running status and display it on the screen to ensure timely and effective maintenance.

© The beauty of technology sensing

With a faulty display, It can accurately analyze the running status and display it on the screen to ensure timely and effective maintenance.

Comprehensive security system

The FUJI GROUP escalator series adopts a novel, fashionable and creative design, and quietly waits in every corner of the city in an elegant and atmospheric manner.

The strength of the carrying capacity, all of which highlights its advanced technology, reliable carrying and comfortable ride. Industry-leading innovative technology to achieve safe, energy-saving, environmentally friendly green operation, and promote the sustainable development of the city.

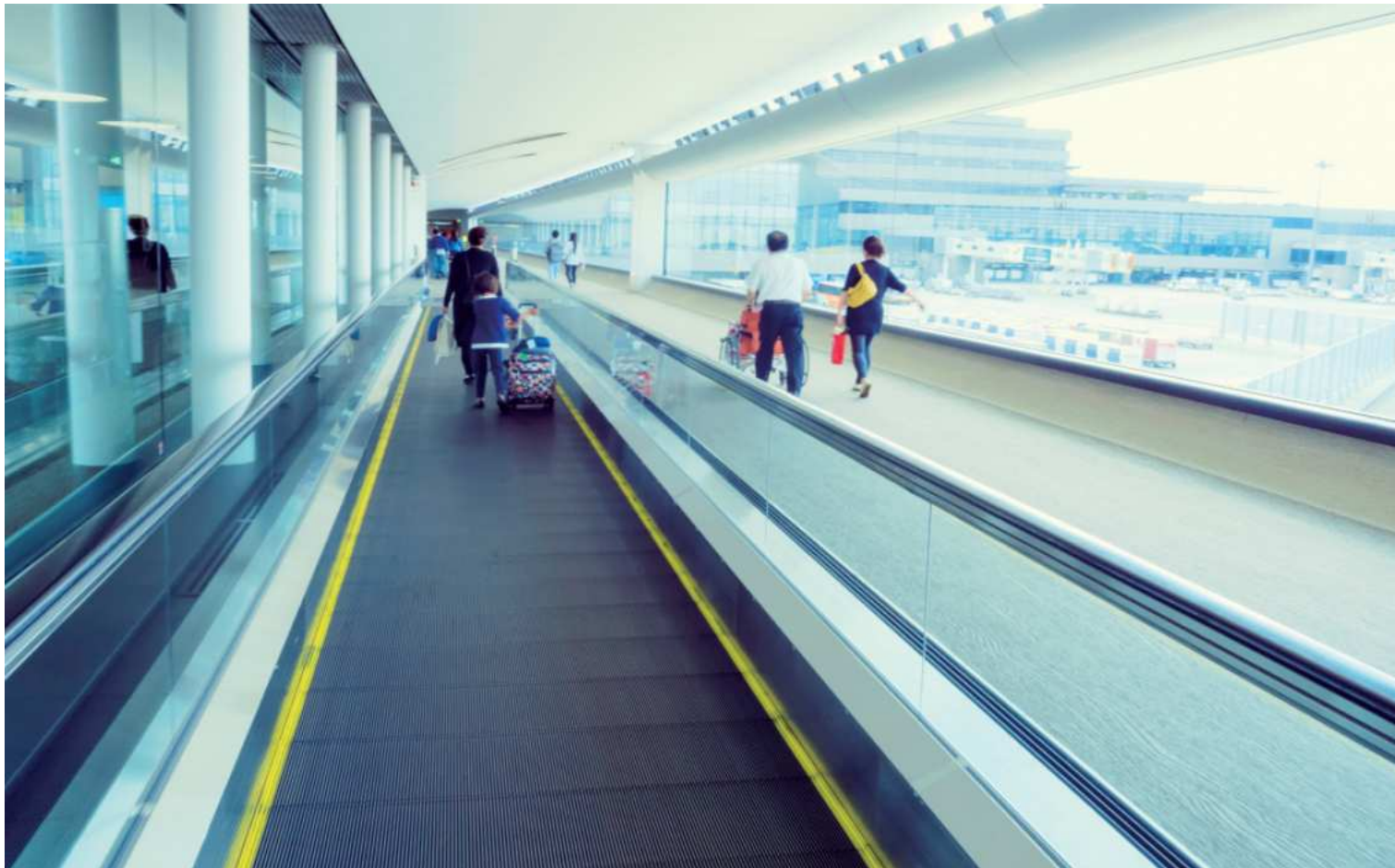

Energy-saving safety device



The integration of a number of international leading technologies and energy-saving safety devices completely eliminates the conventional hidden dangers of ladder chain looseness, step and apron plates, and comb-tooth plate friction, and regular maintenance to ensure safe and smooth operation.

Microcomputer control technology



Adopting international leading computer control technology, controlled by CPU motherboard computer, it can fully monitor the running status of the escalator, detect and eliminate potential safety hazards in time, and ensure the safety of passengers.

Real-time online monitoring



Real-time online monitoring of escalator and sidewalk operations,
Achieve fault warning,
Prevent the occurrence of major accidents,
The first time I found the elevator malfunction,
The first time to solve the fault.

21 national standards development and multiple guarantees for technology patents

Standard safety device	
1 Drive chain break protection	8 Electrical circuit protection
2 Step lighting	9 Motor overload protection
3 Emergency stop button	10 Phase loss, misalignment protection
4 Handrail belt break protection device	11 Overspeed protection
5 Comb plate safety protection device	12 Non-operational reversal protection
6 Brake protection	13 Overhaul safety switch
7 Drive chain break protection	14 Start the alarm device

Standard safety device	Optional safety device
15 Cascade collapse protection device	22 Additional brake (H>6m must be equipped)
16 Warning line	23 Lower machine room drainage
17 Handrail speed monitoring	24 Lower machine room water level detection (outdoor ladder)
18 Apron brush	25 Oil water separator (outdoor ladder)
19 Handrail with entrance protection	
20 Cascade chain break protection	
21 Step loss protection	

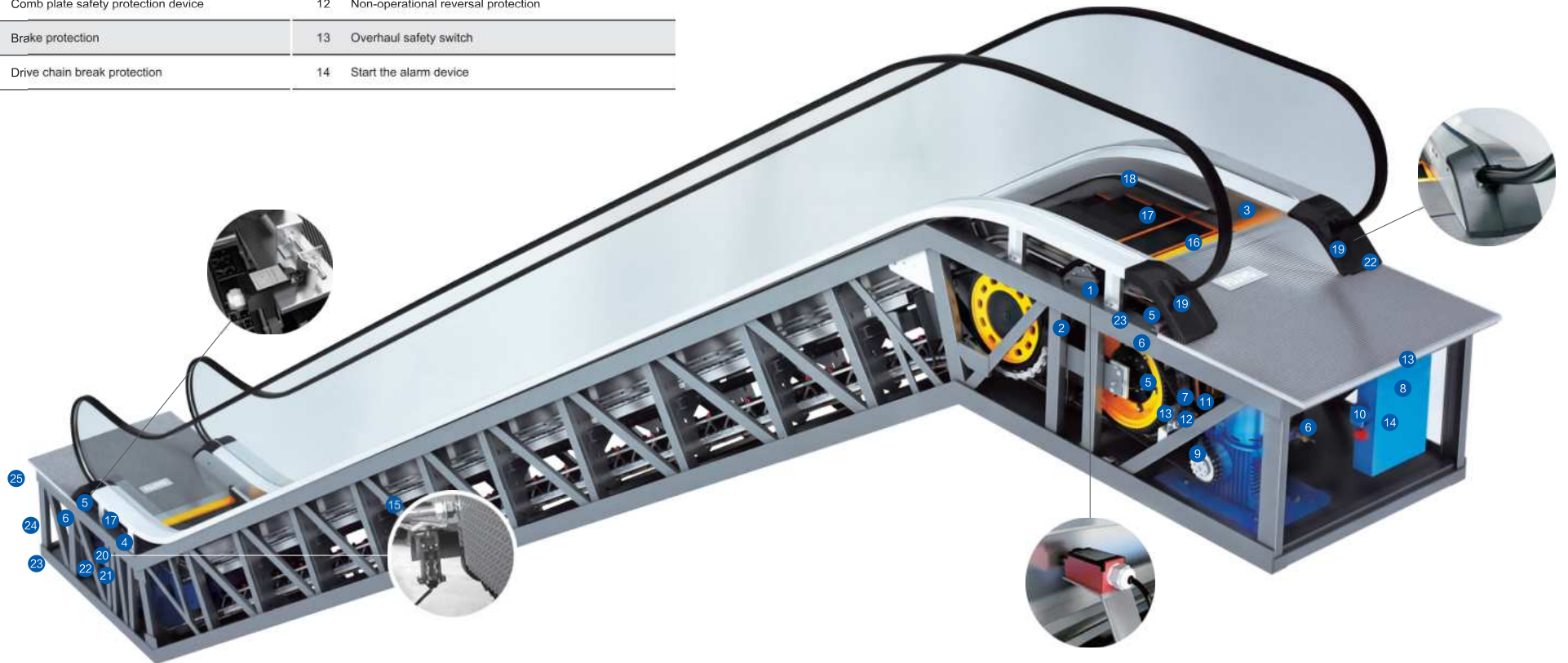

Escalator safety escort

Cover design



When the foreign object is caught between the apron board and the steps, the escalator will automatically stop running.

Handrail entrance security



The entrance of the handrail belt is equipped with a safety device. When the foreign object is caught at the entrance of the handrail, the escalator will automatically stop running.

Cascade sagging protection



The monitoring device should be set up at each of the drive station and the steering station to ensure that no gaps due to missing steps will appear at the entrance, whether the equipment is up or down.

Cascade chain break protection



When the step is found to have an abnormal bend, the escalator will stop running before the step enters the comb plate.

Drive link protection



When the drive chain is overstretched or broken, the escalator will automatically stop running.

Non-operational reversal protection



The sensor is installed on the main brake. When the escalator reverses, the main engine brakes safely.

Comb safety protection



If the foreign object is caught between the moving step and the stationary comb plate, triggering the safety switch on both sides of the monitoring comb plate, the whole ladder will stop automatically.

Step loss detection

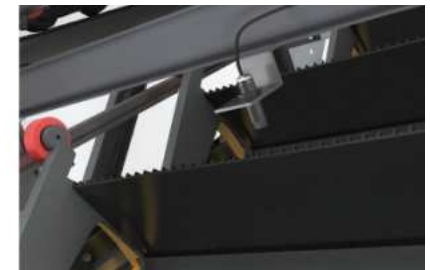

A monitoring device is provided at each of the drive station and the steering station, and when the step is missing, the escalator stops immediately.

Optional function

Comb-board Lighting

White/blue/red

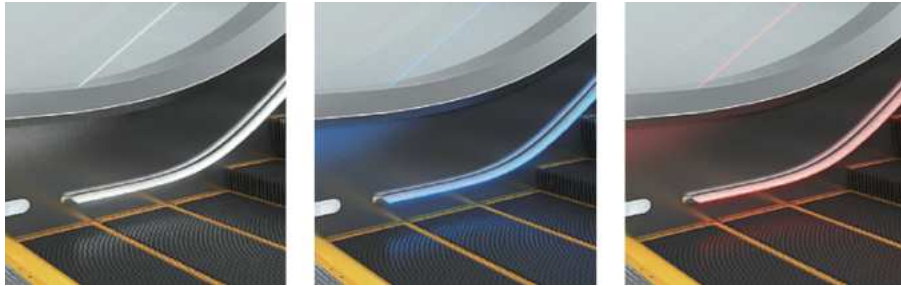

Handrail color

Gray/red/orange/blue



Voice HMI system

Voice prompt ride considerations



Comb

Aluminum alloy

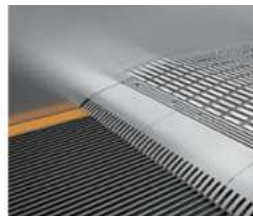

Front panel, floor panel

Aluminum alloy

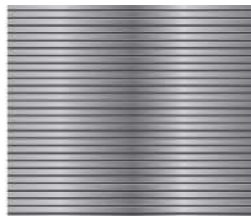

Perfect layout

Intermittent layout (one-way traffic)

Suitable for operation between three floors in a smaller mall.

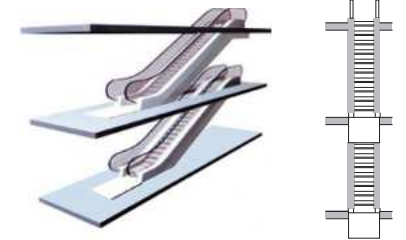

Parallel continuous arrangement (two-way traffic)

This kind of separation is not very convenient for the customer, but it is very advantageous for the owner of the store, because you can provide them with special services on the way to the escalator.

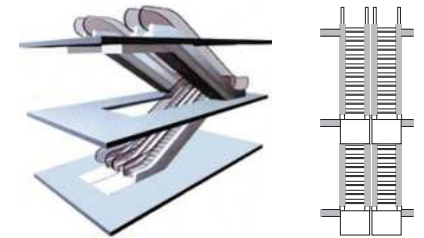

Cross-continuous arrangement (two-way traffic)

The cross-continuously arranged escalators installed in multiple floors can serve two running directions. This form is mostly used in shopping malls, and now more and more used in government agencies and public places, it can reduce between small main floors. Running time.

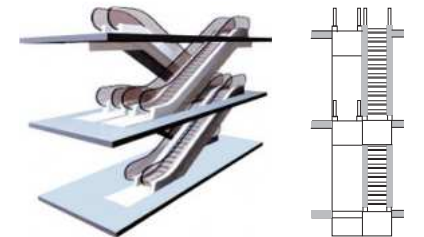

Continuous layout (one-way traffic)

A continuous configuration of escalators or sidewalks that connect several floors. It requires more space than intermittent.

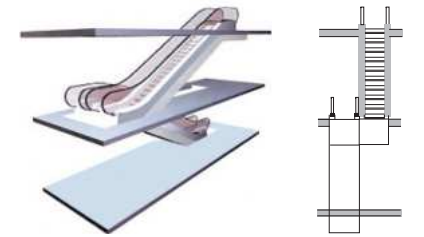

Escalator Construction Parameters

30° Escalator construction layout drawing

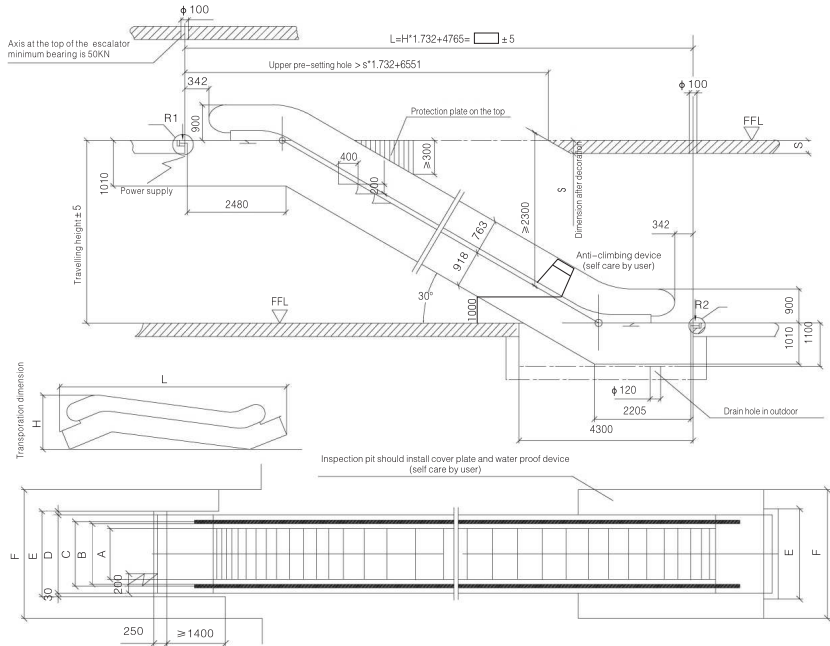

Motor capacity (KW)	Traveling height (Ladder width) 1000		Traveling height (Ladder width) 800		Traveling height (Ladder width) 600	
	1000-3300	5.5	1000-3500	5.5	1000-3700	5.5
800	3600-4500	7.5	3600-4700	7.5	3600-4900	7.5
600	4600-4900	8	4800-5100	8	5000-5200	8
1000	5000-5900	11	5200-5900	11	5300-5900	11
1000	1000	1158	1238	1600	1660	2310
800	800	958	1038	1400	1460	2110
600	600	758	838	1200	1260	1910
Step width	A	B	C	D	E	F
Model	Traveling height (mm)		Bearing Capacity (KN)		Transpiration dimension (h)	
FHE(600)-30 (3600人/h) Speed: 0.5m/s	3000	57	46	41	2750	10900
	3500	60	49	44	2780	11890
	4000	64	52	47	2810	12880
	4500	68	56	50	2830	13870
	5000	71	59	53	2840	14860
FHE(800)-30 (4800人/h) Speed: 0.5m/s	5500	75	62	56	2890	15860
	6000	79	65	59	2970	16860
	3500	59	52	47	2750	11890
	3500	63	56	50	2780	11890
	4000	67	60	54	2810	12880
FHE(1000)-30 (6000人/h) Speed: 0.5m/s	4500	71	64	57	2830	13870
	5000	74	68	60	2840	14860
	5500	82	74	66	2860	15860
	6000	86	78	69	2870	16860
	3000	63	59	53	2750	10900
3500	67	64	57	2780	11890	
4000	71	68	61	2810	12880	
4500	75	73	65	2830	13870	
5000	83	79	71	2840	14860	
5500	87	84	75	2860	15860	
6000	92	88	79	2870	16860	

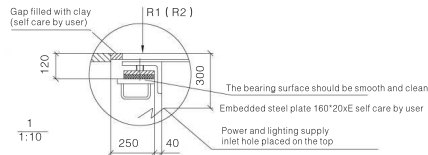

Instruction

- When the escalator to be installed above the second floor. Don't have a pit. Layout drawing must be matched between up and down
- Keep the sufficient space at both EXIT and EXTRANCE of escalator. The width must be less than 1238. The depth from handrail belt reversed end to the front obstacle must be not less than 2500.
- Space between handrail belt of escalator and obstacle must be not less than 500.
- Motor AC 380 V 50 HZ. See in the table.
- By the user to provide a grounding resistance of less than 4 ohms.
- Provide by user to the main switch of the power requirements of 3 phases 5 wires.
- All the dimensions are measured by MM.

35° Escalator construction layout drawing

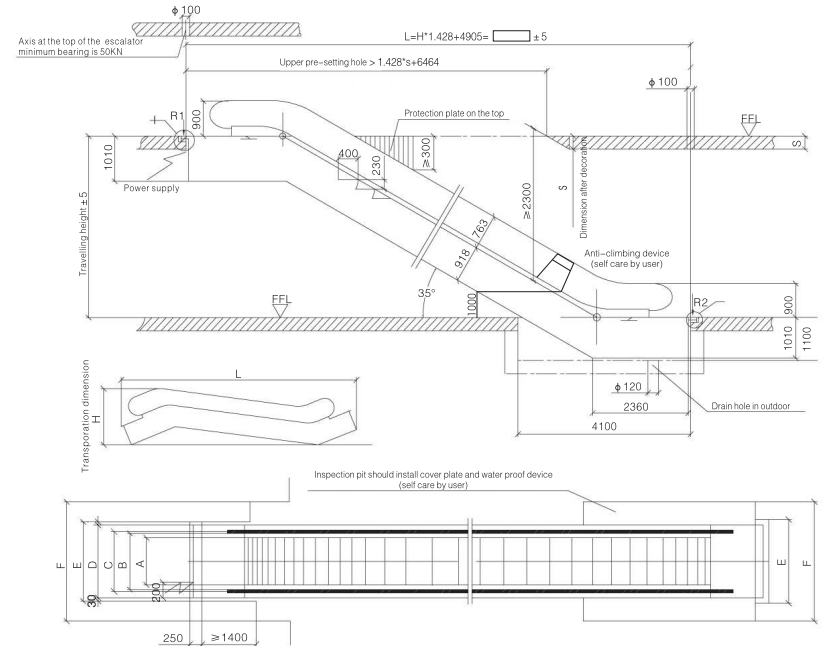

Motor capacity (KW)	Traveling height (Ladder width) 1000		Traveling height (Ladder width) 800		Traveling height (Ladder width) 600	
	1000-3500	5.5	1000-3700	5.5	1000-3900	5.5
800	3600-4700	7.5	3800-4900	7.5	4000-5100	7.5
600	4800-5000	8	5000-5200	8	5200-5400	8
1000	5100-5900	11	5300-5900	11	5500-5900	11
1000	1000	1158	1238	1600	1660	2310
800	800	958	1038	1400	1460	2110
600	600	758	838	1200	1260	1910
Step width	A	B	C	D	E	F
Model	Traveling height (mm)		Bearing Capacity (KN)		Transpiration dimension (h)	
FHE35/600 (3600人/h) Speed: 0.5m/s	3000	54	43	39	2850	10180
	3500	57	46	41	2890	11030
	4000	60	49	44	2920	11890
	4500	64	52	46	2940	12750
	5000	67	54	49	2970	13610
FHE30/800 (4800人/h) Speed: 0.5m/s	5500	70	57	51	2980	14470
	6000	73	60	54	3000	15330
	3000	56	49	44	2850	10180
	3500	60	52	47	2890	11030
	4000	63	56	50	2920	11890
FHE35/1000 (6000人/h) Speed: 0.5m/s	4500	66	59	53	2940	12750
	5000	70	62	56	2970	13610
	5500	73	65	59	2980	14470
	6000	76	69	61	3000	15330
	3000	60	56	50	2850	10180
3500	64	60	53	2890	11030	
4000	67	64	57	2920	11890	
4500	71	67	60	2940	12750	
5000	74	71	64	2970	13610	
5500	82	77	69	2980	14470	
6000	85	81	72	3000	15330	

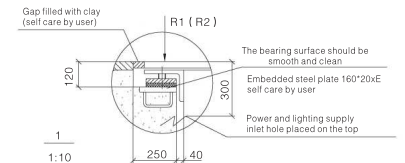

Instruction

- When the escalator to be installed above the second floor. Don't have a pit. Layout drawing must be matched between up and down
- Keep the sufficient space at both EXIT and EXTRANCE of escalator. The width must be less than 1238. The depth from handrail belt reversed end to the front obstacle must be not less than 2500.
- Space between handrail belt of escalator and obstacle must be not less than 500.
- Motor AC 380 V 50 HZ. See in the table.
- By the user to provide a grounding resistance of less than 4 ohms.
- Provide by user to the main switch of the power requirements of 3 phases 5 wires.
- All the dimensions are measured by MM.

Moving Walk Construction Parameters

0° Moving walk construction layout drawing

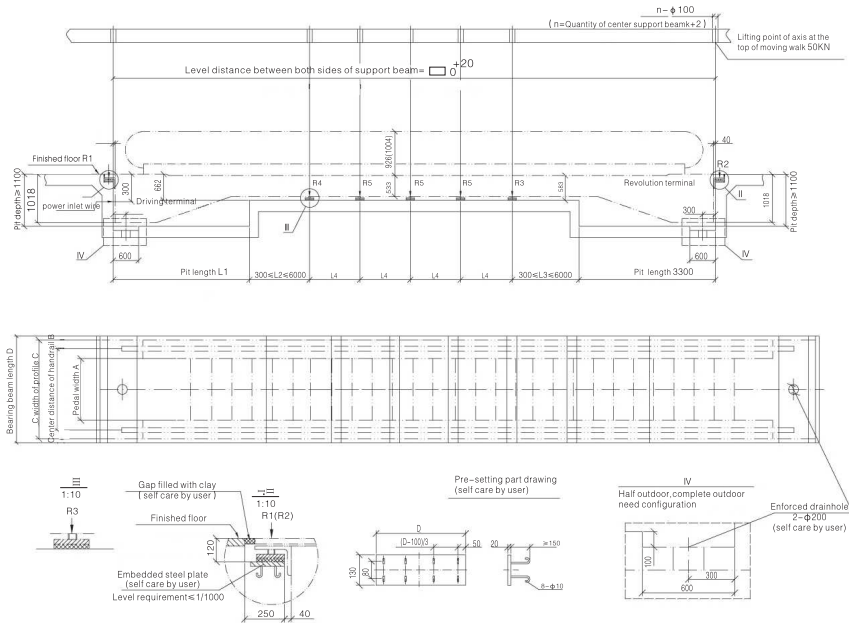

Pedal width		1000		800	
Quantity of center support beam L4		6000	10000	6000	10000
Support opposite force (KN)	R1	40	38	35	34
	R2	34.5	34	32	31
	R3	62.5	78.5	52	64.5
	R4	63.5	79.4	54	66.6
	R5	48	79.4	40	66.6
Motor capacity / rated current		conveyor length		conveyor length	
		10000-70000	8KW/18A	10000-80000	8KW/18A
		70001-110000	11KW/25A	80001-110000	11KW/25A

Notes

- When the operating environment temperature under 0° (outdoor or semi-outdoor) need increase heater.
- Sufficient unblocked space is needed at entrance and exit of moving walk and the width should be the center distance at east, the depth (from handrail turn end) should be 2.5m at least, this area width should more than two times of the handrail center distance, the depth can be reduced to 2m.
- If have the pit should have waterproofing work (self-care by user).
- The distance between moving walk and any barrier should ≥ 500 , or the Triangle place of handrail and floor should install protecting board (self-care by user).
- User provide power supply and earth connection equipment with resistance less than 4 ohm, it should leave Two meters left margin line under the upper supporting beams, motor capacity according to left form.
- Luminance at least should be 50Lx at entrance and exit of indoor moving walk, luminance at least should be 15Lx at entrance and exit of outdoor and semi outdoor (self-care by user).
- If the middle supporting beam use steel frame structure, please ask Hengda Fuji Elevator Company for advice.
- Two sides and bottom decoration of moving walk self-care by user.

Technical notes	
Dip angle α	0-6°
Speed V	0.5m/s
Pedal type	aluminium alloy (indoor/half outdoor /complete outdoor)
Pedal width A	1000 800
Handrail center distance B	1238 1038
Moving walk outside width C	1600 1400
Machine supporting beam length D	≥ 1650 ≥ 1460
Installation place/drive mode	Length L1
Indoor/star delta	4000
Indoor/frequency	
Semi-outdoor/star delta	4600
Semi-outdoor/frequency	
Outdoor/star delta	4000
Outdoor/frequency	4600
Power supply	
User needs to supply 380V 50Hz three-phase five-wire power supply. Voltage should ≤ 10 when moving walk at the start and the voltage should be ≤ 5 in normal operation. Maximum starting current should less than 3.5 times of rated current.	

Installation Notice

- Besides complying with the drawing of the contract, attention should also be drawn to the following
- To ensure the safety of the escalator and moving walk, free space should be large enough in the landing area. (See the minimum size left)
- C= the distance of the handrails

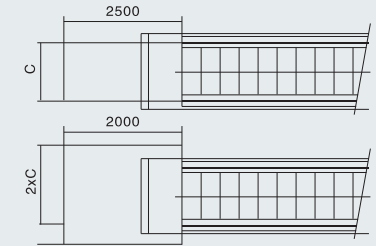

- Note: The graphical 1,2,3,4 safety devices function after the escalator installation and before the examination. They are at the users' own expense.

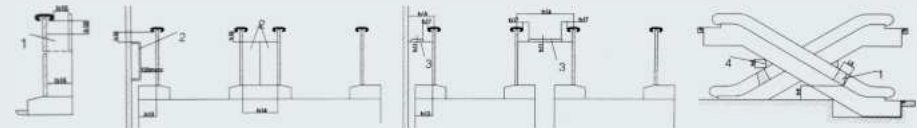

Description

- Anti-creep device (5.5.2.2)
- Blocking device (5.5.2.2)
- Anti-skid device (5.5.2.2)
- Vertical apron (A.2.4)

Vertical apron	Clauses	Vertical apron	Clauses
b13, b14, b15, b16	5.2.2.2	h10=25mm-150mm	5.2.2.2
b17 ≥ 100 mm	5.5.2.2	h11 ≥ 20 mm	5.5.2.2
h5 ≥ 0.30 m	A.2.4	L5 ≥ 1000 mm	5.5.2.2
h9=(100±50)mm	5.5.2.2	b10=80mm	

- Note: Graphical representation is not proportional. It is only used for graphic illustration.

- Outer cover plate of escalator / moving walk shall install anti-creep device (1). Please refer to above table for installing height of anti-creep device and extension length L5 of outer cover plate. Its height shall be the same as that of handrail surface. It shall also accord with the graphic stipulations.
- When escalator / moving walk is adjacent to the wall, outer cover plate width b13 ≥ 125 mm, blocking device (2) shall be installed in upper / lower end. It prevents the people from entering into outer cover plate area. When escalator / moving walk is adjacent to paralleled layout, common outer cover plate width b14 > 125 mm, the blocking device shall also be installed. It shall be extended to height h10.
- When handrail cover-plate which is close to handrail height is installed between escalator / inclined moving walk and adjacent wall, and distance between building (wall) and handrail central ling b15 is larger than 300mm, anti-skid device (3) shall be installed in handrail cover plate. Distance between anti-skid device and handrail shall $\geq b17$. Spacing distance between anti-skid devices shall ≤ 1800 mm. Height h11 shall ≥ 20 mm. The device has no sharp angle / edge. As for adjacent escalator / inclined moving walk, when distance between handrail center-lines b15 > 400 mm, anti-skid device shall be installed. It shall also satisfy above requirements.

Full service, heart-to-heart connection

Our service not only ensure your security, but also guarantee your investment in the equipment aspects. The true service is to foresee and satisfy the special requirements from vast customers because the service's definition varies according to the customers' demands. Therefore we should have the extensive and characteristic methods to satisfy these requirements.



**Enjoyable Service
Perpetual Satisfaction**

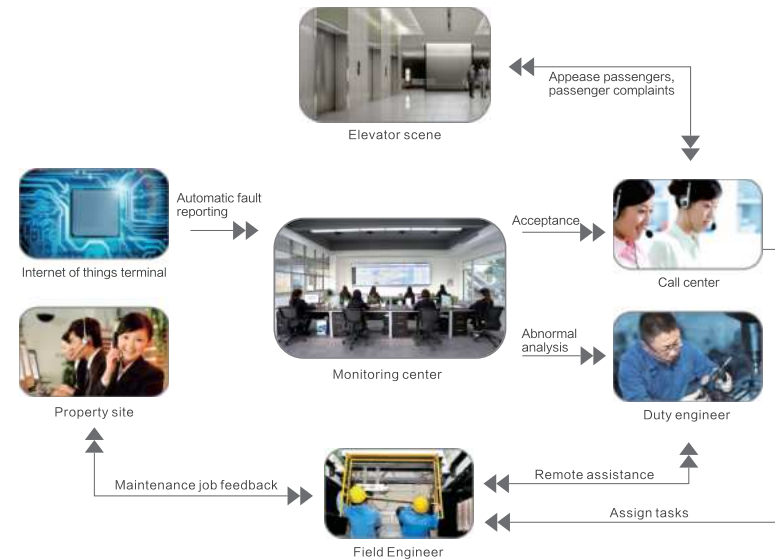

- **Service Center**

From building projects for customers to lifelong service of the products, FUJI GROUP elevator provides customers meticulous services with great consideration through all the procedures.

- **The national wide after-sale service network**

FUJI GROUP elevator sets up many branches in the domestic cities. We provide the local customers first time response and prompt replacement parts supply.

- **24-hour urgent air service**

24-hour customer hotline setted for troubleshooting offers high-quality after-sales service within the shortest period.

- **Monitor network**

FUJI GROUP elevator regularly assigns staff to detect your equipment's operation conditions and provides the most professional maintenance.