

**FÖHR**

JH200

## Contact Resistance Tester



# Contents

I.Introduction .....	1
II.Specification.....	1
III.Technical Index .....	2
IV.Instrument Operation Function .....	2
V.Operation Menu .....	3
VI.Connection Method .....	6
VII. Communication .....	7
VIII.Safety Precautions .....	7
IX.Guarantee And After Sales Service .....	7
X. Packing List .....	8

## **I.Introduction**

FÖHR JH200 Contact resistance instrument is a carefully developed high precision, digital switch detection instrument by the IEC standard And PRC's Latest electric power execution standard DL/T845.4-2004 Regulations. The Instrument adopt High frequency high power constant current switching power supply technology to detect the Micro ohm contact resistance. The Instrument is widely used for varieties of the switches and Contact resistance of switches and electrical appliances, contact resistance and Power cables, contact resistance of welding seam detection.

The measurement data is accurate and correct, high stability and satisfy the requirements of Power, power supply department on-site high-voltage switch repair and high voltage switch factory contact resistance test. Output current and measurement resistance output at the same time in the 7-inch high brightness touch color liquid crystal, measurement results can be stored on the U disk, power off storage can meet the data query at any time.

## **II.Specification**

1. The instrument can be controlled by the whole process of the instrument through the special software of the mobile phone, and the test data can be stored in a fixed format on the mobile phone, so as to facilitate data query at any time.
2. It has a variety of protective functions, such as reverse potential impact, disconnection, power failure and overheat during the test, which can reliably protect the impact of reverse potential on the instrument and give synchronous sound alarm.
3. Intelligent power management technology, the instrument always works in the minimum power state, effectively saving energy and reducing heat.
4. Output high voltage, measurement range is wide.
5. The test current comes from the high precision current constant current power supply, without manual adjustment, the test is fast and accurate.
6. Four terminal connection methods are adopted to effectively eliminate the influence of the test line resistance on the test results.
7. seven inches high brightness touch color LCD, strong light display clear, full touch



3. I+、 I- :Current output terminal, supply the constant current to the tested object by special testing wire.

4. V+、 V- : Input voltage terminal for tested object.

5. LCD: 320X240 true color LCD, under the bright, font can also be clearly observed, display operation settings, test results, contact resistance value and output current value.

6. RS232: Serial port.

7.  $\perp$  : Ground terminal.

8. USB: U disk storage connector.

9. Printer: Thermal printer, prints the testing results.

## V.Operation Menu

1、 The boot interface is shown in figure 1:



Figure 1

2、 Press "Data test" to enter the following interface, as shown in figure 2

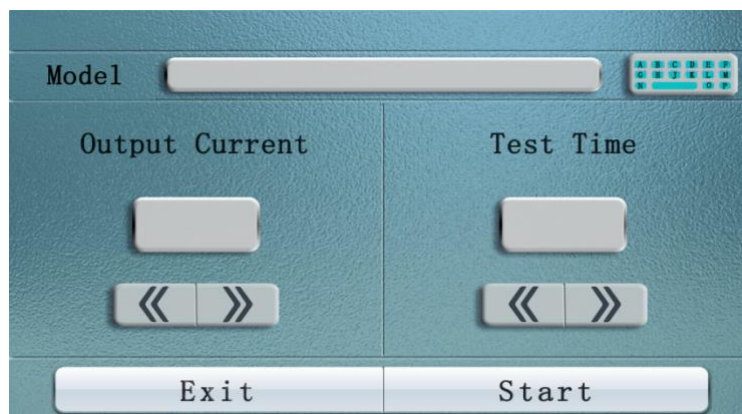





Figure 2

**Model of test product:** Click  to edit the name of test product;

**Test current:** Click  The current circulates between 50A and 100A;

**Test time:** Click  Test time: cycle between 10S、30S、45S、60S、300S、600S、999S

3、 After the current is selected, click "**Start test**", which shows that "please wait while charging" enters the test state. After a few seconds, the test result will be displayed, as shown in figure 3

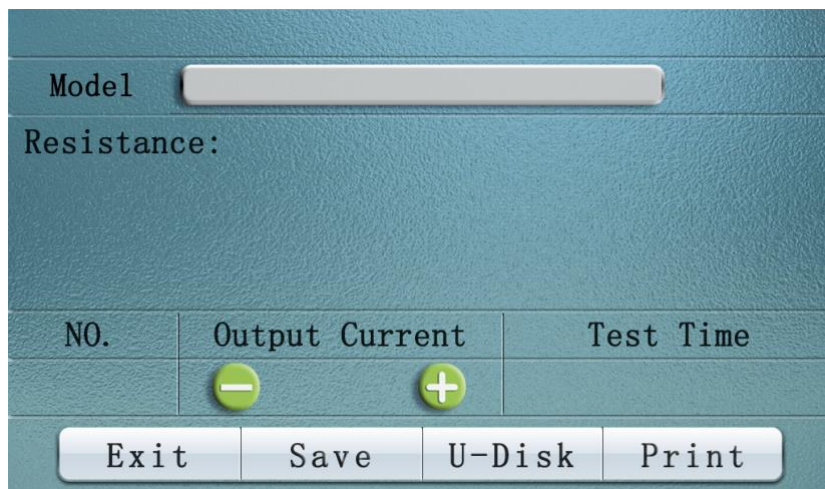



Figure 3

After displaying the test results, you can click  After displaying the test results, you can click to directly switch the current without returning to the main interface. After switching the current, you can wait patiently for the test results after a few seconds. Next, you can save the test results by "**local storage**", or click "**U disk storage**" and "**print**". Click "**return to main page**" and "**return to main interface**";

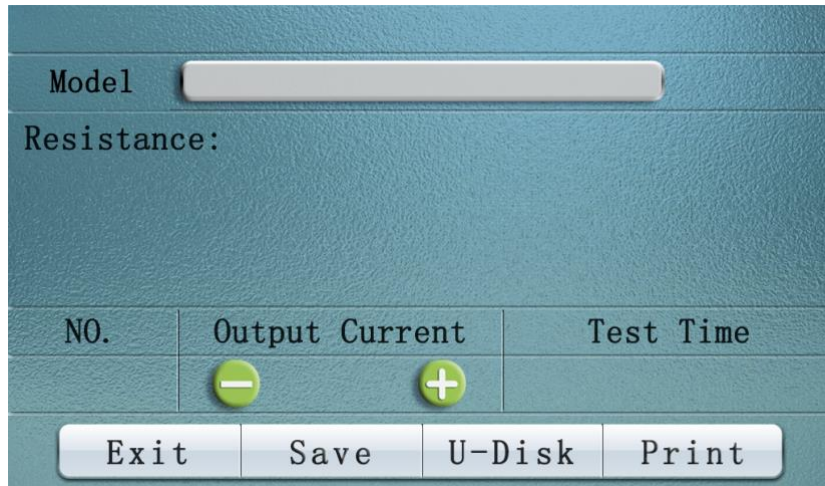



Figure 4

Click   to query the historical data and delete the data, or to store and print the data on the U disk. Click return to the home page and return to the main interface.;

5、Click "parameter setting" in figure 1 to enter the "parameter setting" interface, as shown in figure 5:



Figure 4

**Brightness adjustment:** according to the scene environment, the screen brightness can be adjusted by moving the button

**Language setting:** click the button to switch the Chinese/English interface

**Manufacturer Settings:** only manufacturer can set

Click the Settings to return to the home page and return to the main interface

6、Click "clock modification" in figure 1 to enter the clock modification interface, as shown in figure 6:

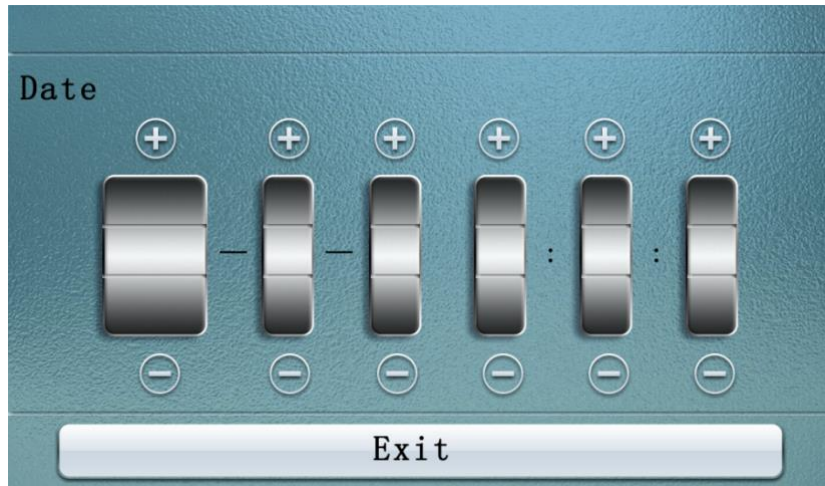

Figure 6

Click   to set date and time;

## VI.Connection Method

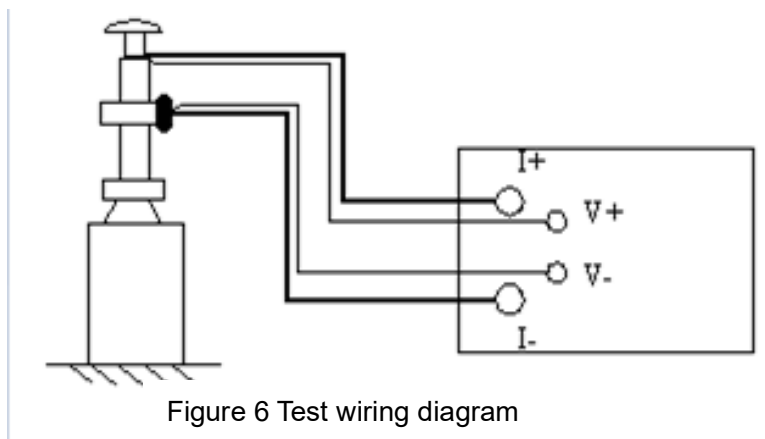

Figure 6 Test wiring diagram

**Note:** All the connection should be reliable connected with the tested object, if the contact surface oxidation, firstly should remove the contact surface oxide.

- 1, wiring methods: as shown in Figure 2, special test line the color red to red, black to black, the thicker current line connected with corresponding I +, I - terminal screws tightly, the thinner power line inserted into the socket V +, V -, two clamped tested on the product ends.
- 2, measure: complete the connection as Graph 2, turn on the power switch, choose the testing time for testing, the instrument will automatically charging, constant current and measuring resistance.

## **VII. Communication**

Steps to connect the phone to the instrument:

1. The instrument is powered on and turned on
2. Turn on the Bluetooth function of the mobile phone and click "Search for Devices"
3. Select the corresponding device (device name format is "HLxxxxxxxx") from the searched devices to connect. Enter the "1234" pairing code in the Bluetooth pairing request box, click OK, and wait for the device to match successfully.
4. Open the software and click the gray Bluetooth icon in the upper right corner of the homepage. Select the device that just matched successfully in the pop-up menu.
5. After the wait for connection prompt in the software disappears, the connection is successful.

## **VIII. Safety Precautions**

1. Handlers should have common sense of electrical equipment or tester
2. Enter "reset" after finishing measurement, and turn off power. Attention: strictly forbid dismantle all wires live wire
3. Enter "reset" to replacing when the tester breaking.
4. The tester must be served by professional person, prohibit make it by yourself.
5. The tester only for measurement contact resistance, prohibit measurement inductive contact resistance.

## **IX. Guarantee And After Sales Service**

After service: 1 years of warranty and lifetime maintenance and supporting technology. Please contact our company on time if the tester breakdown, so we'll arrange the fastest disposing way.

## X. Packing List

No.	Item	Qty
1	Main engine	1
2	Red test line	1
3	Black test line	1
4	Power line	1
5	Ground lead	1
6	Fuse pipe	2
7	Print paper	1
8	Test sample (Standard resistance)	1
9	Serial port line	1

Made in China

# FÖHR Group Electrical Measurement Equipment

MANUFACTURED BY H.E.M.B. CO.LTD

**CE/ISO/CNAS/IAF CERTIFIED**

[info@fohrgroup.com](mailto:info@fohrgroup.com)

[www.fohrgroup.com](http://www.fohrgroup.com)

## LEGAL DISCLAIMER AND LIMITATION OF LIABILITY

(Intellectual Property and Manufacturing Responsibility Statement)Effective Date: JANUARY 2025.This Legal Disclaimer and Limitation of Liability Statement ("Statement") is issued by FÖHR (the "Brand").1. Manufacturing Structure.FÖHR is a commercial brand engaged in the marketing and distribution ofelectrical testing and industrial equipment. FOHR does not design, engineer, develop, or manufacture the products directly. All products bearing the FOHR brand name are manufactured, assembled, or produced by independent third-party original equipment manufacturers (OEMs) and contract manufacturers under private-label or contract manufacturing agreements.FÖHR operates solely as a brand owner and distributor.2. No Ownership of Underlying Technology.FÖHR does not claim ownership of any underlying patents, utility models, industrial designs, trademarks, trade secrets, copyrights, proprietary software, firmware, embedded systems, or other intellectual property rights associated with the engineering or technological development of the products unless expressly stated in a separate written agreement.All intellectual property rights remain the sole responsibility of the respective manufacturers or lawful rights holders.3. Intellectual Property Compliance Responsibility.Each independent manufacturer supplying products to FÖHR represents and warrants that: The products do not infringe any third-party patents, trademarks, copyrights, industrial designs, trade secrets, or other intellectual property rights.The products comply with applicable international intellectual property laws, including but not limited to:The TRIPS Agreement (WTO) The Paris Convention for the Protection of Industrial Property.The Berne Convention for the Protection of Literary and Artistic Works.Applicable national patent, trademark, and copyright laws in the jurisdictions where the products are manufactured or sold.FÖHR relies in good faith on such representations from its manufacturers.4. Disclaimer of Liability for Intellectual Property Claims.To the fullest extent permitted by applicable law, FOHR shall not be held liable for:Any alleged or actual patent infringement; Trademark violations;Copyright infringement;Misappropriation of trade secrets;Unauthorized use of proprietary technology; Design rights violations;Or any other intellectual property claim arising from the manufacture, design, engineering, or technological development of the products.Any claims relating to intellectual property infringement shall be directed exclusively to the original manufacturer responsible for the design and production of the goods.5. No Independent Technology Development.FÖHR does not reverse engineer, modify core technologies, or alter proprietary engineering components supplied by its manufacturers. FOHR does not independently develop internal circuitry, embedded firmware, measurement algorithms, or proprietary testing methodologies associated with the equipment.6. Indemnification by Manufacturers.Manufacturers supplying products under the FÖHR brand are contractually required to indemnify, defend, and hold harmless FÖHR, its directors, officers, shareholders, affiliates, distributors, and agents from and against any claims, damages, liabilities, costs, or expenses arising from alleged intellectual property violations.7. Jurisdictional Limitation.Nothing in this Statement shall exclude or limit liability where such exclusion is prohibited by mandatory law in any applicable jurisdiction. In jurisdictions where limitations of liability are restricted, FÖHR's liability shall be limited to the maximum extent permitted by law.8. No Admission of Liability.This Statement does not constitute an admission of liability, infringement, wrongdoing, or legal responsibility of any kind.9. Governing Law.This Statement shall be governed by and construed in accordance with the applicable commercial laws of the jurisdiction in which FÖHR is legally incorporated, without regard to conflict of law principles