

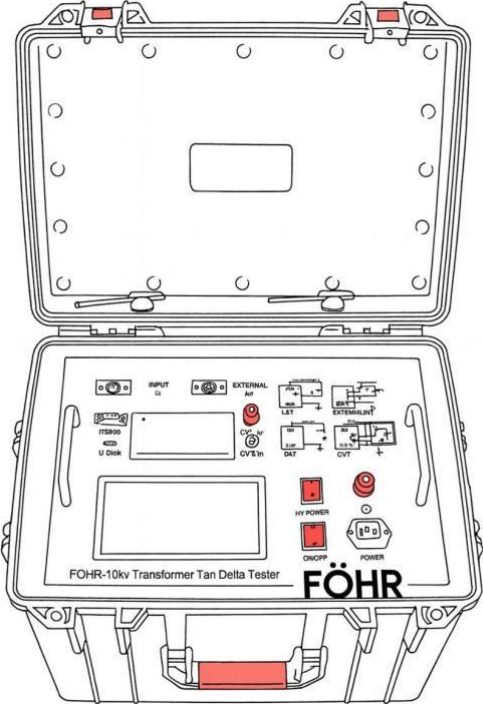

# FÖHR-2000H

Transformer Tan Delta Tester



# INSTRUCTION MANUAL

## Contents

I.Summary of Instrument .....	1
II.Security Measures .....	1
III.Performance Feature .....	2
IV.Technical Indicators.....	4
V.Measurement Method and Principle .....	5
VI.Common Equipment Wiring Method.....	6
VII.Brief Introduction to Instrument Functions .....	10
VIII.Instrument Operation Procedure .....	12
IX.Notes for Test .....	20
X.Discussion of Frequency Conversion Measurement.....	22
XI.Packing List of Instrument.....	24





## **I.Summary of Instrument**

Dielectric loss measurement is a very basic method in insulation test, which can effectively find out the whole damp deterioration and local defects of insulation of electrical equipment. It is widely used in electrical manufacturing, electrical equipment installation, handover and preventive test. The measurement of dielectric loss of transformer, mutual inductor, reactor, capacitor, bushing and lightning arrester is the most basic method to measure its insulation performance. The dielectric loss tester has broken through the traditional bridge measurement method, adopting frequency conversion power supply technology, using single chip microcomputer and modern electronic technology to carry out automatic frequency conversion, mode/number conversion and data operation. Strong anti-interference ability, fast test speed, high precision, automatic digitization, easy operation; Power supply adopts high-power switching power supply, output 45Hz and 55Hz pure sinusoidal wave, automatically pressurize, can provide up to 10 kv voltage; Automatic filter 50Hz interference, suitable for substation and other electromagnetic interference large field test. Widely used in the power industry transformer, mutual inductor , casing, capacitor, lightning arrester and other equipment dielectric loss measurement.

## **II.Security Measures**

- 1.Read this manual carefully before using this instrument.
- 2.The operator of the instrument should have general knowledge of the use of electrical equipment or instruments.
- 3.This instrument can be used both inside and outside, but it should be kept away from places such as rain, corrosive gas, excessive concentration of dust, high temperature and direct sunlight.
- 4.Instrument should avoid violent vibration.
- 5.The maintenance, care and adjustment of the instrument should be carried out by professionals.
- 6.Before any connection, the grounding terminal of the instrument must be reliably connected with the earth with an earth cable.

7. Due to the high voltage generated by the test equipment, the tester must strictly follow the safe operation procedures and prevent others from contacting the high-voltage components and circuits. Direct test personnel must fully understand the high-voltage test circuit, and instrument operation points. Non-engaged testers must stay away from the high-pressure test area, which must be clearly marked with fences or ropes, warning signs, etc.

8. The adjustment, repair and maintenance of the instrument must be carried out without electricity. If it must be live, the operator must be very familiar with the high voltage dangerous parts of the instrument.

9. When the fuse is damaged, the same insurance must be replaced. It is forbidden to replace different types of insurance or directly short circuit the insurance.

10. When the instrument fails, turn off the power switch and wait for one minute before checking.

### **III. Performance Feature**

1. The instrument adopts Fourier transform digital filtering technology to measure capacitance, dielectric loss and other parameters. The precision of the test results is high, which is convenient for automatic measurement.
2. The instrument adopts frequency conversion technology to eliminate 50Hz power frequency interference in the field, and reliable data can be measured even in the environment of strong electromagnetic interference.
3. Use full-touch super large LCD, easy to operate. Full touch LCD screen, large full graphical operation interface, each process is clear, operators do not need additional professional training to use. The whole process can be measured with a touch.
4. Data storage: it is equipped with calendar chip and large-capacity memory, which can save the test results at any time, check the history record at any time, and print out. The current time and storage time can be displayed and printed at any time.
5. The instrument is easy to operate, and the measurement process is controlled by the microprocessor. As long as the appropriate measurement method is selected, the data measurement can be completed automatically under the control of the microprocessor.

6. Integrated model, with standard capacitor and high-voltage power supply, facilitates field testing and reduces field wiring.
7. The measurement accuracy of the instrument is high, which can meet the requirements of oil dielectric loss measurement. Therefore, the measurement of oil dielectric loss can be achieved only by equipping standard oil cup and special test line.
8. It has reverse wiring low-voltage shielding function. When the 220kV CVT bus is grounded, 10kV reverse wiring dielectric loss measurement can be performed on the C11 without removing the wires.
9. Able to do ac withstand test. It is convenient for PT, CT secondary side ac withstand voltage, 400V low-voltage system to do the withstand voltage test.
10. It can identify the frequency of external high voltage power supply (40Hz~70Hz), and allow the use of frequency power supply or serial resonant power supply to conduct large-capacity and high-voltage dielectric loss test.
11. With CVT test function, CVT self-excitation test can be realized, and 4 protection limits of high voltage/current and low voltage/current can be set to ensure the safety of person and equipment.
12. When testing CVT, not only the capacitance and dielectric loss values of C1 and C2 can be automatically tested, but also the total capacitance and dielectric loss values of CVT equipment can be tested
13. Equipped with thermal printer for printing and output, with calendar clock.
14. With a computer interface. A computer can control 32 instruments, which can be integrated into the comprehensive high-voltage test vehicle to achieve measurement, data processing and report output.
15. Grounding protection function, when the instrument is not grounded or the grounding is bad, the instrument does not enter the normal program, does not output high voltage. Over-current protection, the instrument will not be damaged in short circuit or breakdown.
16. Electric shock protection function: when the operator of the instrument accidentally touches the electric shock, the instrument will immediately cut off the high voltage to ensure the safety of the test personnel.

## IV. Technical Indicators

Accuracy: Cx:  $\pm$  (readings $\times$ 1%+1pF)

tg $\delta$ :  $\pm$  (readings $\times$ 1%+0.00040)

Anti-interference index: frequency conversion anti-interference, can still achieve the above accuracy under the interference of 200%.

Capacitance range:

Internal high voltage: 3pF $\sim$ 60000pF/10kV      60pF $\sim$ 1 $\mu$ F/0.5kV

External high voltage: 3pF $\sim$ 1.5 $\mu$ F/10kV      60pF $\sim$ 30 $\mu$ F/0.5kV

Resolution: up to 0.001 pF, 4-bit significant digits

Tg $\delta$  range: no limit, The resolution is 0.001%. The capacitance, inductance and resistance can be identified automatically.

Test current range: 10 $\mu$ A $\sim$ 5A

Internal high voltage:

Setting Voltage Range: 0.2 $\sim$ 10kV

Maximum output current: 200mA

Boost and drop voltage mode: the voltage is set at will. Such as 5123 v.

Test frequency: 40-70Hz single frequency can be set at will. For example, 48.7 Hz.

50 $\pm$  0.1Hz to 50 $\pm$ 10Hz automatic dual frequency conversion optional setting.

60 $\pm$  0.1Hz to 60 $\pm$ 10Hz automatic dual frequency conversion optional setting.

Frequency accuracy:  $\pm$ 0.01Hz

External high voltage: maximum test current 5A, power frequency or frequency conversion of 40-70Hz during positive connection

Maximum test current 10kV/5A, power frequency or frequency conversion 40-70Hz

CVT self-excitation method low voltage output: output voltage 3 $\sim$ 50V, output current 3 $\sim$ 30A

Measurement time: about 40s, related to measurement method

Input power: 180V  $\sim$  270VAC, 50Hz $\pm$ 1%, municipal or generator power supply

Printer: micro thermal printer  
 environment temperature:  $-10^{\circ}\text{C} \sim 50^{\circ}\text{C}$   
 relative humidity:  $<90\%$   
 Overall dimension:  $430 \times 330 \times 350\text{mm}$   
 Weight: 28kg

## V.Measurement Method and Principle

According to whether the tested product is grounded or not, there are two kinds of measurement methods, namely, the forward connection measurement method and the reverse connection measurement method. The principles of the two measurement methods are shown in figure 1:

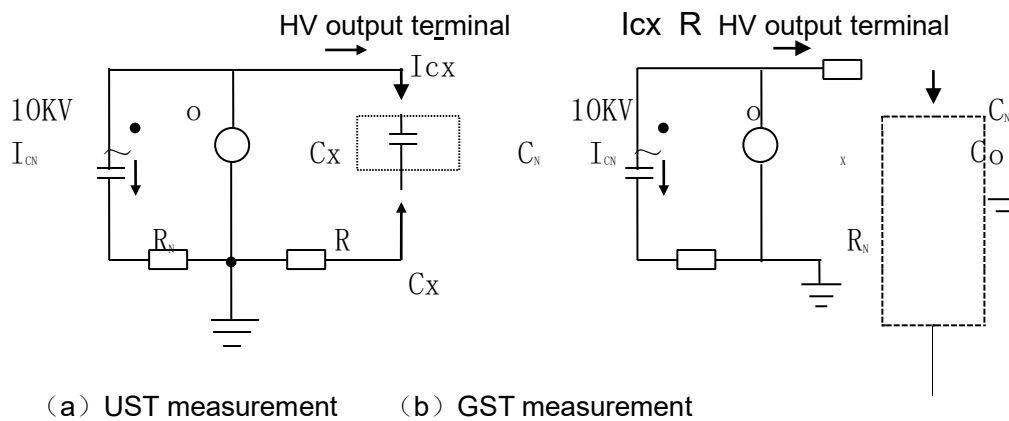

Figure 1

At the 10kV side of the high-voltage power supply, the high-voltage power supply is divided into two channels, and the first channel feeds the standard capacitor  $C_N$  inside the machine. The dielectric loss of this capacitor is very small, which can be considered as zero, i.e. pure capacitive current. This current  $I_{CN}$  can be used as the capacitive current reference. On the  $C_X$  test side, the test current  $I_{CX}$  is collected into the machine through the sampling resistance  $R$ . The  $I_{CX}$  can be decomposed into horizontal and vertical components, as shown in figure 2.  $\text{tg}\delta$  value can be obtained by calculating the ratio of the horizontal and vertical components.

In FIG. 1 (a),  $C_X$  is the ungrounded sample, and the sample current  $I_{CX}$  enters the sampling resistance  $R$  from the sample end to obtain the full current value. In FIG. 1 (b),  $C_X$  is the grounding sample, the  $C_X$  end of the machine is directly grounded, and the current

I<sub>c</sub>x obtains the full current value from the high-voltage end of the sample to the sampling resistance of the machine.

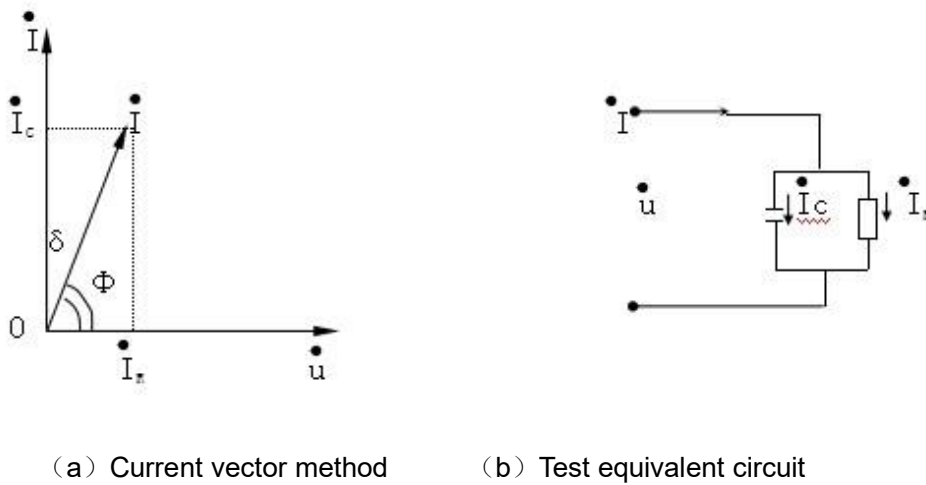

Figure 2

## VI. Common Equipment Wiring Method

### 1. Description of instrument outlet terminal:

HV — high voltage (with dangerous voltage) on the measuring lead of the instrument.

CX — Input terminal of measured current in case of UST.

⊥ — the grounding end of the instrument is reliably connected with the earth during use

### 2. Wiring reference

#### 2.1 UST(Positive wiring), internal reference capacitor, internal HV (conventional UST):

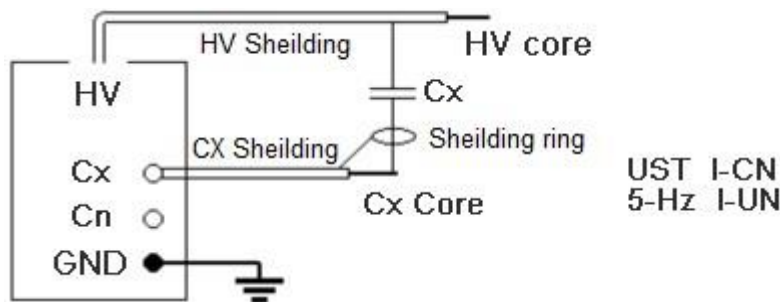

#### 2.2 GST(Reverse wiring), Internal Standard Capacitance, Internal High Voltage

(Conventional Reverse Wiring)

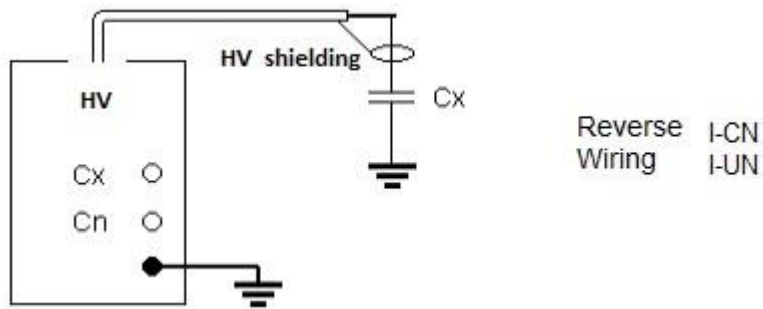

2.3 UST(Positive wiring), external standard capacitance, internal high voltage:

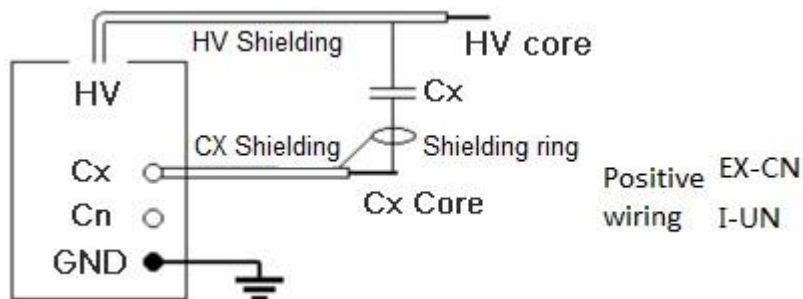

2.4 GST(Reverse wiring), external standard capacitance, internal high voltage:

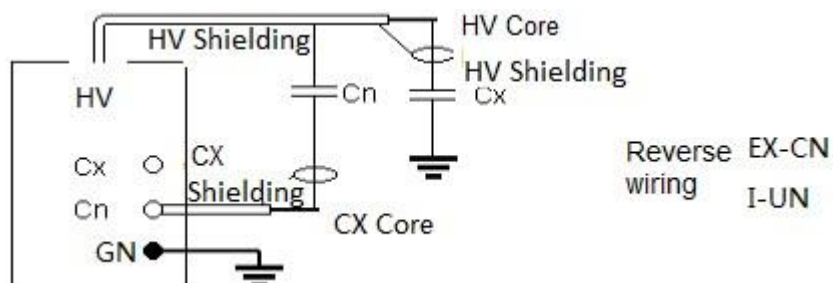

2.5 UST(Positive wiring), Internal Standard Capacitance, External High Voltage:

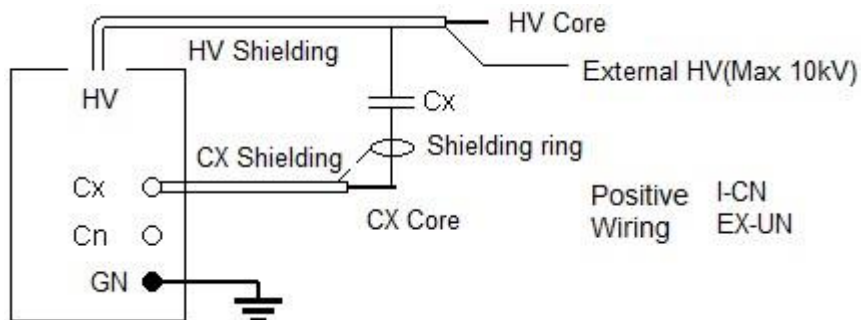

2.6 GST(Reverse wiring), Internal Standard Capacitance, External High Voltage:

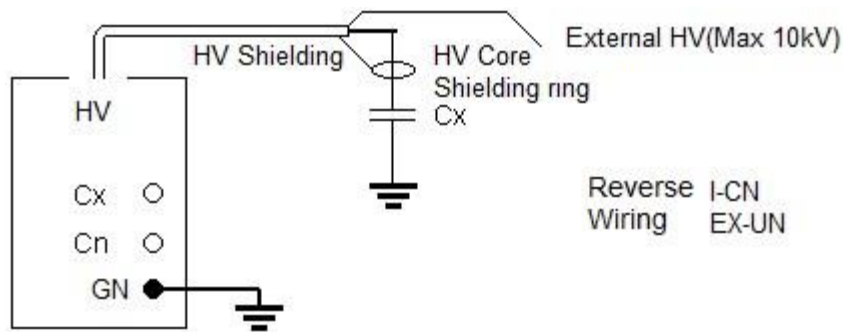

2.7 UST(Positive wiring), External Standard Capacitance, External High Voltage (High Voltage Dielectric Loss):

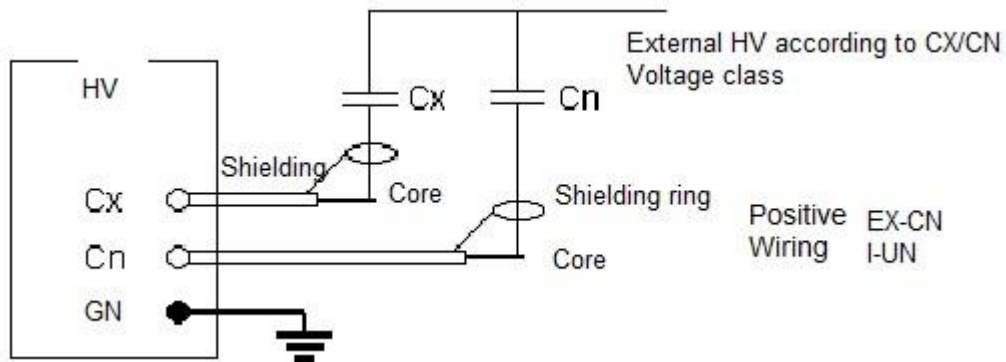

2.8 GST(Reverse wiring), External Standard Capacitance, External High Voltage:

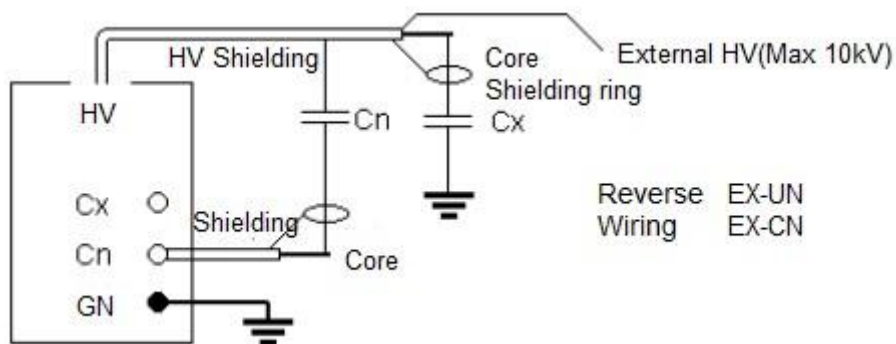

2.9 CVT self-excitation measurement:

CVT self-excitation method can be connected according to the following figure. If C1 is a single saving capacity, the bus cannot be grounded; If C1 is multi-saving capacity, the

bus can be grounded, C11 and C12 can be measured by conventional positive and negative wiring, and C13 and C2 can be measured by self-excitation method.

In CVT self-excitation measurement, the instrument first measures C1, then automatically inverts C2, and automatically calibrates the partial voltage effect.

It should be noted that the high-voltage wire should be suspended and not touch the ground, otherwise the additional dielectric loss to the ground will cause errors. The high-voltage socket can be connected with the CVT test product with a thin cable and hoisted.

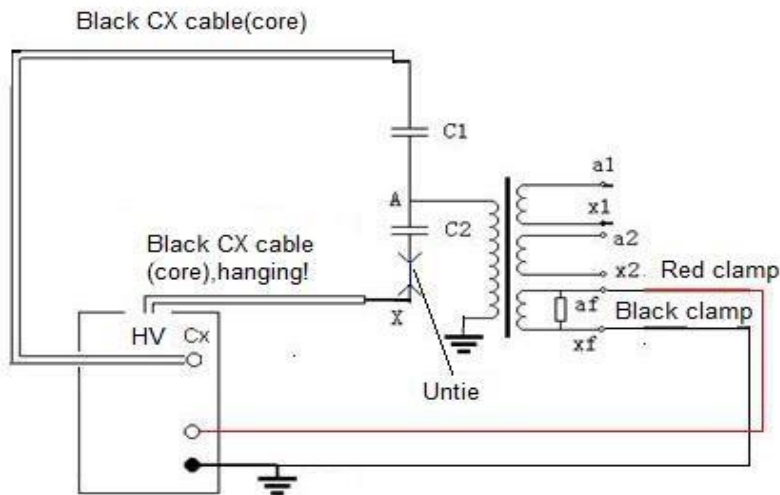

### 2.10 GSTG Reverse wire low voltage shielding test

GSTG Reverse wiring low voltage shielding function, the primary wiring can measure both the capacitance and dielectric loss of C1 and C2

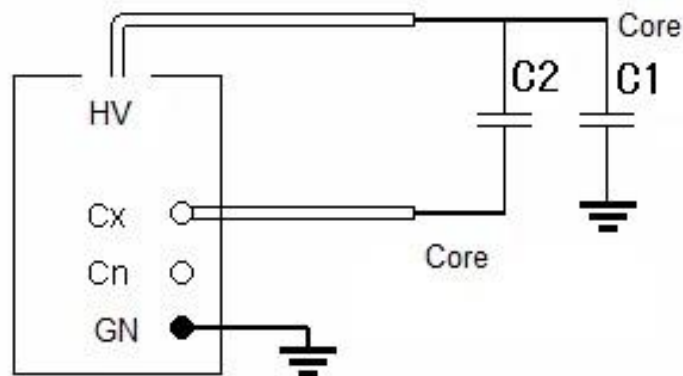

By selecting the GSTG reverse wiring low-voltage shield, 10kV reverse wiring dielectric loss measurement can be carried out on the upper capacitor C1 without removing the busbar. As shown in the figure below: the busbar is grounded, the upper end of C1 is not disassembled, the lower end of C1 is connected to the high-voltage core wire, and the end of C2 is connected to the Cx core wire. The instrument adopts the reverse wiring /10kV/M

measurement mode, which can measure the capacitance and dielectric loss of C11 and the lower shielding part at the same time.

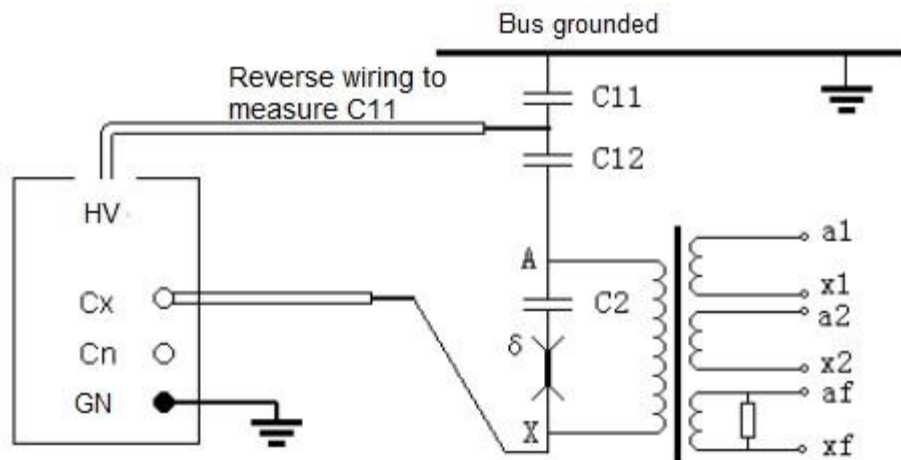

## VII. Brief Introduction to Instrument Functions

The Instrument Panel is Shown in Figure 9 Below

1. CX socket -- is the measurement input end of the test product signal. It is connected by a special low-voltage cable during the positive connection. This cable is single-layer shielded with a special crocodile clip, which is 8m long and connected to the low-voltage end of the test product. This end is empty when reverse wiring.
2. Color touch screen display -640\*480 resolution, control and display menu and various prompt information and measurement results.
3. Printer -- print measurement data.
4. CN socket -- is the measurement input end of outer standard capacitive signal, which is empty when using inner standard.
5. Self-excitation current output terminal -- special terminal for measuring CVT, generally connected with auxiliary winding dn.
6. Self-excitation current output terminal -- special terminal for measuring CVT, generally connected with auxiliary winding da.
7. Power switch - power on and off.

8. High voltage switch - responsible for the starting and closing of high voltage power inside the instrument. Only when using external high pressure to close, the rest of the time should be in the open state.
9. Power socket -- AC 220V $\pm$ 10%, 50 $\pm$ 1Hz power input port, with 5A fuse.
10. Grounding terminal -- the grounding terminal.

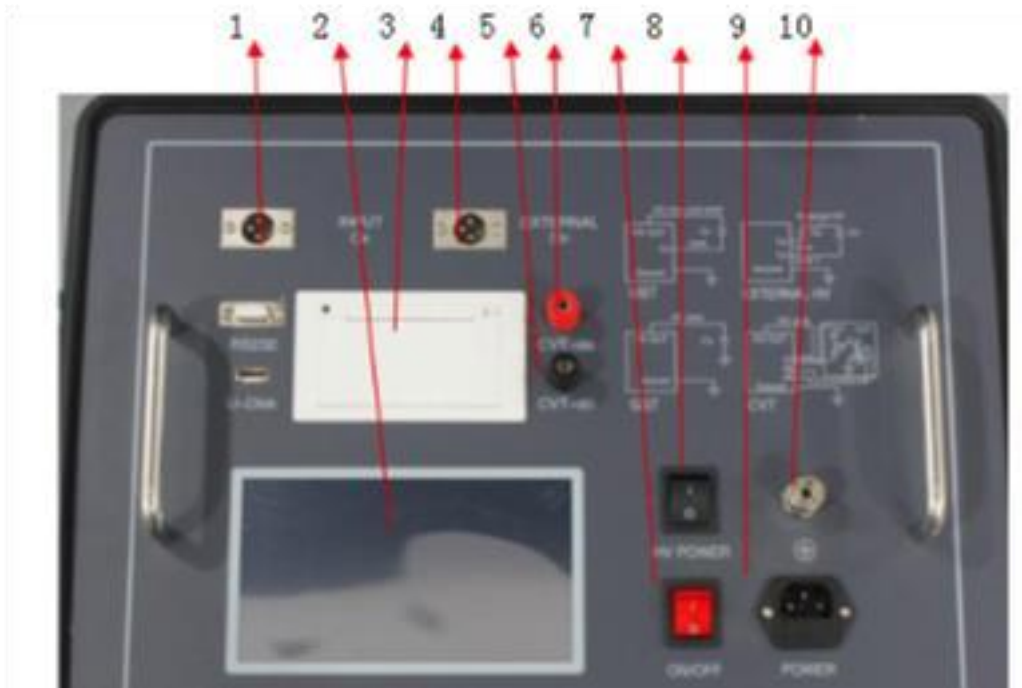

FIG. 9 Instrument panel

13. High voltage wiring diagram of instrument side  
High voltage HV socket

High voltage grounding shielded socket (the interior is already grounded, just plug it in))



The small black clip is high voltage shield, generally suspended (with high voltage)

The big red clip is connected to the high voltage part under test

## VIII. Instrument Operation Procedure

1. Turn on the power switch and conduct self-check. If the self-check is good, the LCD will display the starting interface in FIG. 10.

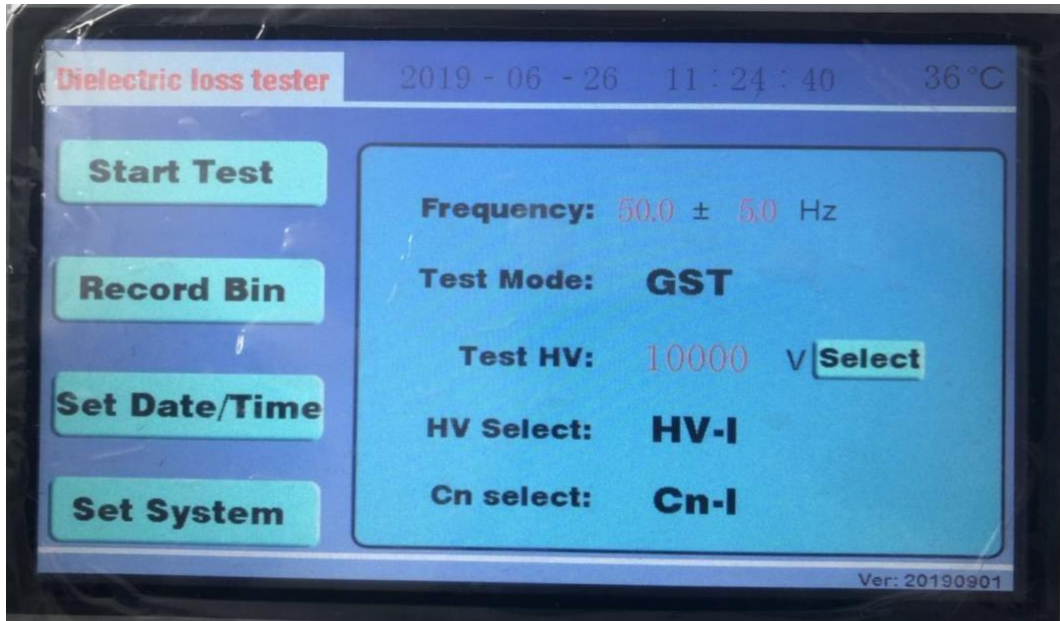

Figure 10 Start-up interface

## 2. Description of test parameter selection

1) test frequency:  $50.0 \pm 5.0$  hz means 45/55hz dual frequency conversion test. Generally, the field test is  $50 \pm 5$  Hz or  $60 \pm 5$  Hz. You can choose something else, of course. If you want a single frequency test such as 50Hz, you can choose  $50.0 \pm 0.0$  hz. Here the frequency value is set at will in the range of 40-70.

2) test mode: reverse wiring means using reverse wiring mode to test products. Here is the drop-down menu. You can choose forward connection, reverse connection, CVT dielectric loss and reverse connection low-voltage shield.

3) test voltage: 10000V represents the value of test voltage. Minimum 100V, maximum 10000V. The voltage value here can be set at will, such as 7892V.

4) high voltage selection: internal high voltage means the use of internal high voltage power supply. General test must be set to internal high pressure.

External high voltage is only used when external high voltage power supply is connected.

5) standard selection: internal standard means the use of internal standard capacitance.

General test must be set to the internal standard.

External standard is only used when external standard capacitors are used.

Note: external standard, external high voltage are used for large capacity or high voltage dielectric loss. The general equipment of substations can be tested with the internal standard and internal high voltage.

### 3. Modification and selection of test parameters:

- 1) To test the modification of the frequency, click the "45.0±0.0Hz" scarlet letter with the stylus or finger. Display Figure 11

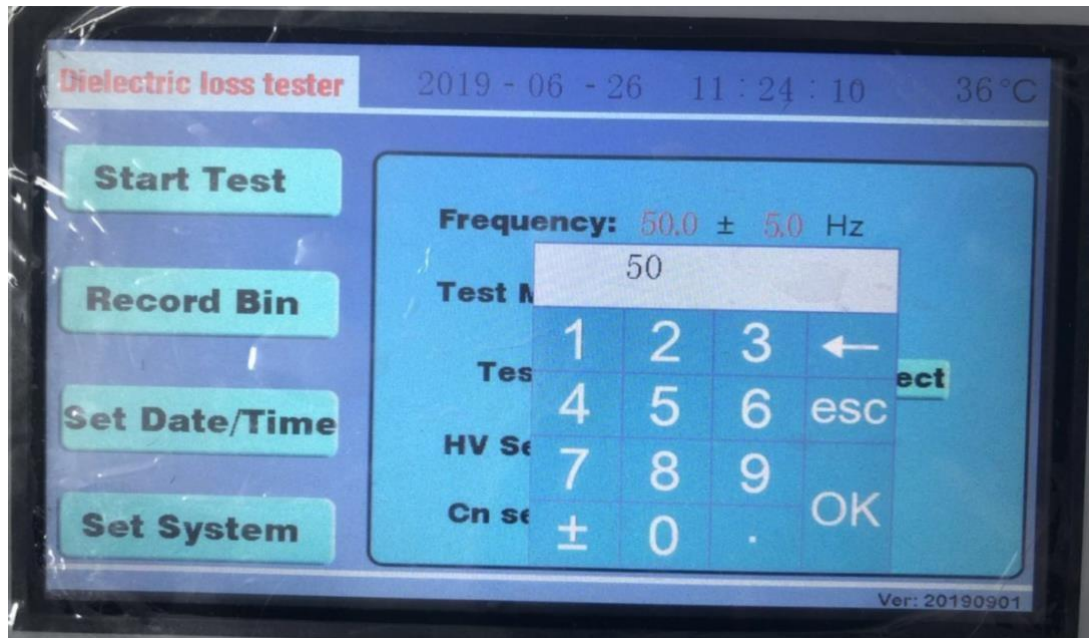

Figure 11 Frequency modification diagram

Enter the frequency value 50 directly from the keyboard and press OK. If you press OK, it will be 50.0±0.0Hz.

If "45.0±0.0Hz" "±0.0" is modified, use a stylus or finger to click on the scarlet letter 0.0 to appear the keypad, and then input 5.0 from the keypad and press OK.

- 2) The modification of test voltage is the same as the modification frequency. Use a stylus or finger to click on the red letters in "test voltage 5000 V". The little keyboard pops up. Enter the test voltage value of 10000 directly on the keypad, and press OK, the keypad disappears. The value of the test voltage will become the value just entered from the keyboard.
- 3) To modify the test mode, click "Reverse wiring" with a stylus or finger. Figure 12 is displayed

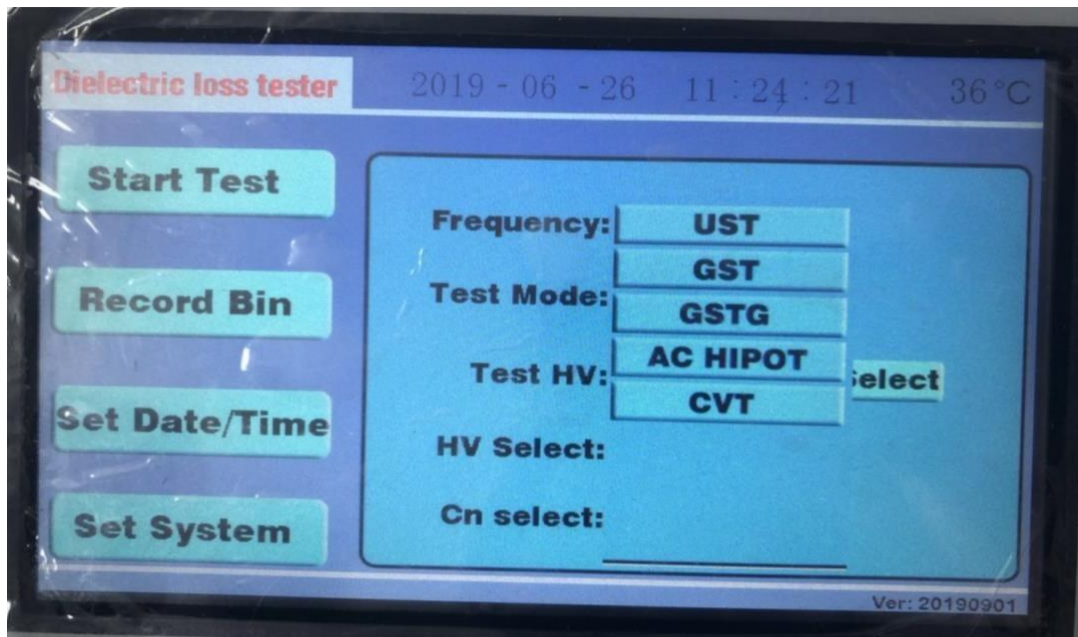

Figure 12 mode selection modification diagram

All test modes are on the drop-down menu. Click on the mode you want to select.

Positive wiring, reverse wiring, CVT dielectric loss, low voltage shielding of reverse wiring.

4) The modification of high-voltage selection is the same as the modification of test mode.

With a touch-screen pen or finger click on the "internal high pressure", the drop-down menu appears in the high pressure, external high pressure, click on the high pressure you want to choose.

5) The modification of standard selection is the same as the modification of test mode.

With a touch-screen pen or finger, click on "Internal Standard" to display the "Internal Standard" and "External Standard" in the drop-down menu. Just click on the standard you want to select.

#### 4. Preparation before measurement:

1) One end of the grounding wire is connected with the grounding column of the instrument, and the other end is connected with the earth reliably to ensure that the instrument shell is on the ground potential.

2) Positive wiring: insert the high-voltage cable plug into the HV socket of the back door, clamp the red pliers at the other end to the high-end lead of the tested product, and hang the black pliers or clamp them on the red pliers. Insert the CX low voltage cable into the

CX socket, and the red clamp at the other end, the Black clamp suspended or connected with the shielding device at the lower end of the sample.

3) Reverse wiring: insert the high voltage cable plug into the HV socket of the back door, clamp the red pliers at the other end to the high-end lead of the tested product, and suspend the red pliers or connect the shielding device. Cx socket is not used. **5. Testing process**

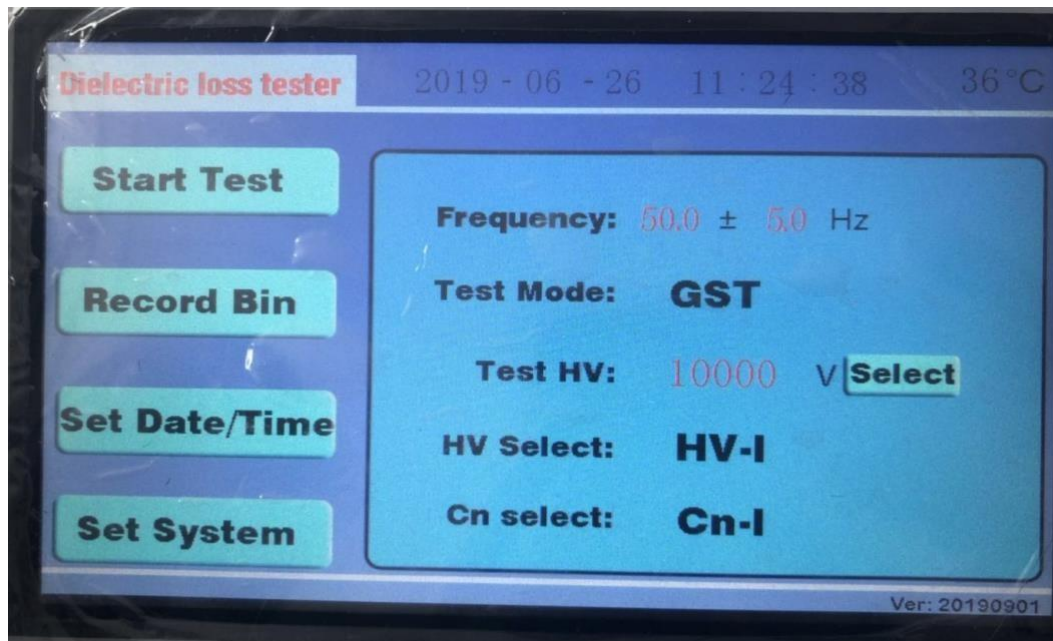

FIG. 13 interface before instrument starts test

Select the test items, test frequency, test voltage, etc., as shown in FIG. 13.

After making sure the wiring is correct, click "start instrument test" with a stylus or finger.

The instrument starts boosting, measuring,

See FIG. 14 and 15.

The instrument adopts dual frequency conversion test. Figure 14 is 55Hz test and figure 15 is 45Hz test.

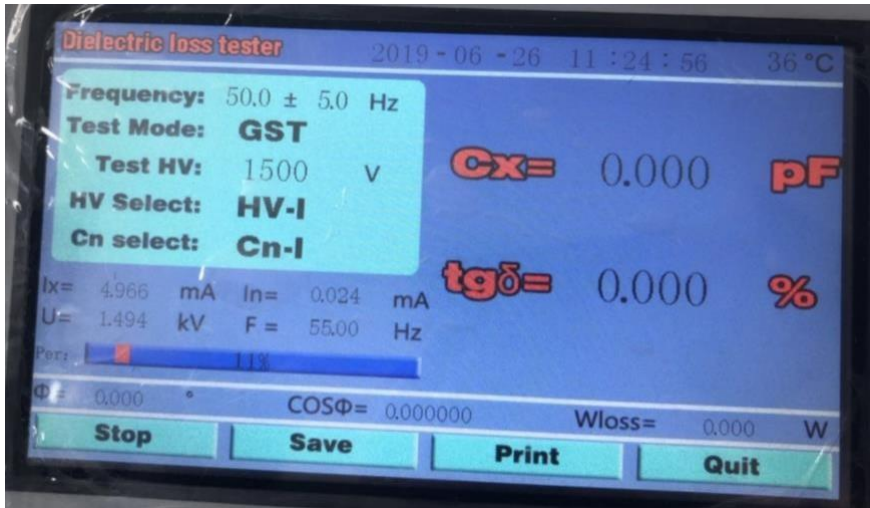

FIG. 14 instrument 55Hz test

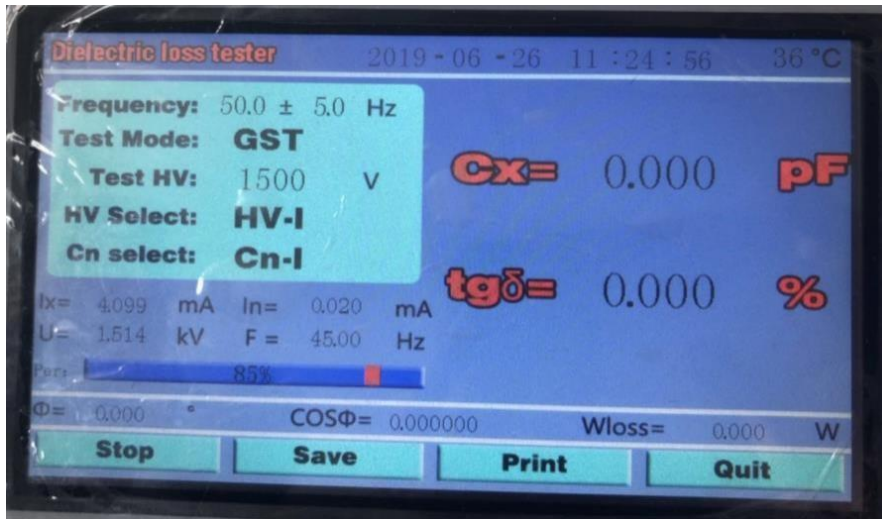

FIG. 15 instrument 45Hz test

6. Test results:

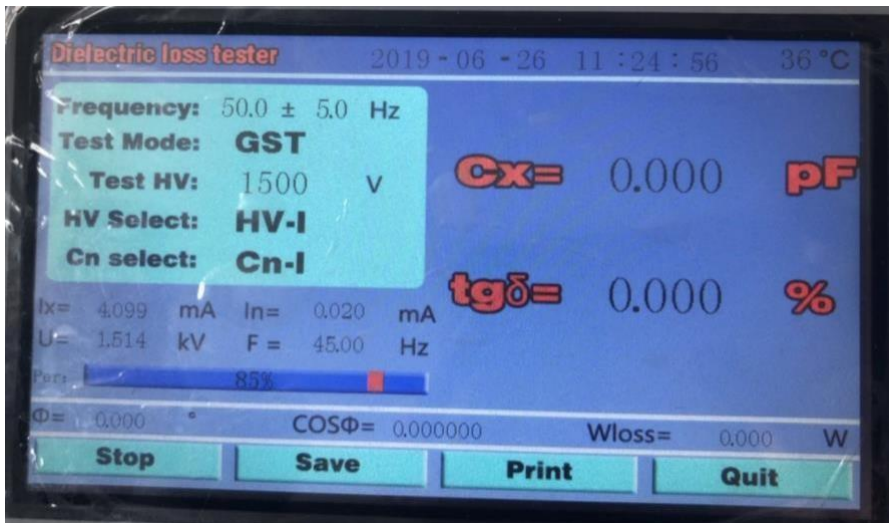

Fig. 16 Test results of reverse wiring

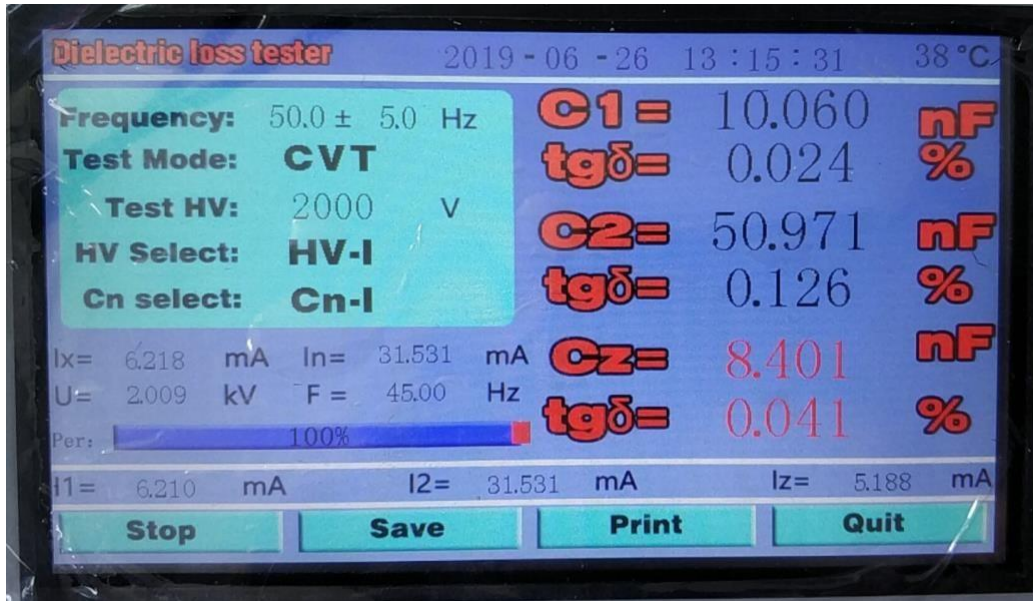

Fig. 17 CVT test results

The capacitance value and dielectric loss value of C1 and C2 are the values of C1 and C2 of CVT equipment.

The capacitance and dielectric loss of CZ are the total capacitance and dielectric loss of CVT equipment.

$K = 252.927 E3$  Represents the variation ratio of  $252.927 \times 1000$ .

$\Phi = 128.603^\circ$  Represents the angular difference of 128.603 degrees.

### 7. Test finished, event processing

1) Test data can be stored after testing. Click the "store" button with the stylus or finger, and figure 18 appears

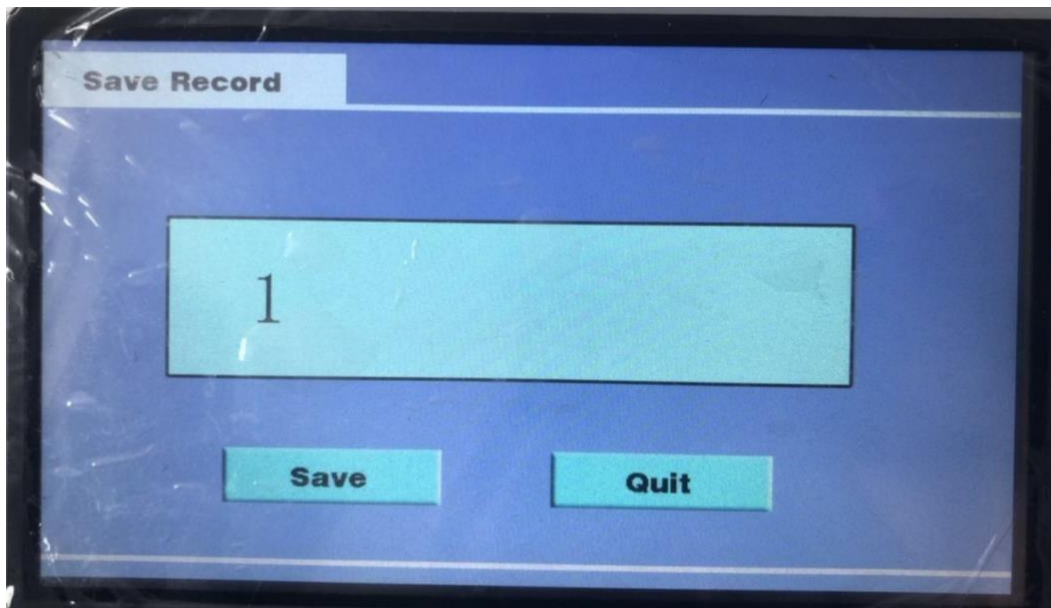

FIG. 18 data storage interface

Click "1" in the data number box with a stylus or finger, and a keypad will appear. Figure 19 below is the data input interface

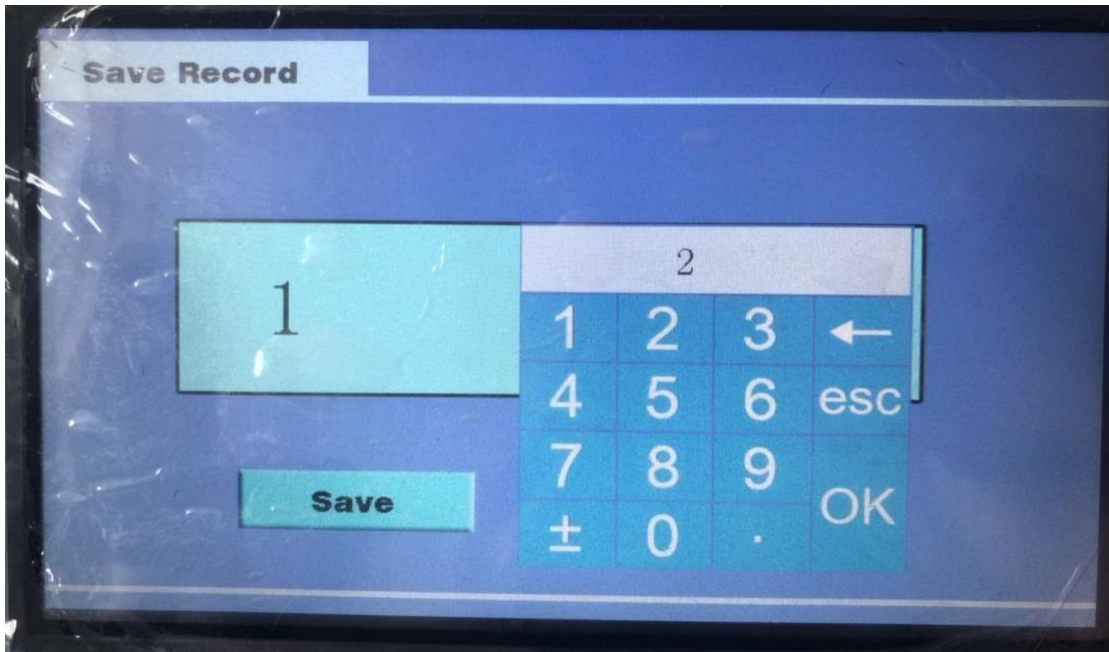

Figure 19 serial number data input interface

Enter the storage number and press OK. The data number 5 appears in the data number box. Press "store", the instrument will beep, and then return to the interface of test results, indicating that the storage is finished.

2) Test data printing. After the test, click the "print" button with the touch pen or finger under the test result interface to print the test data. Figure 20 below is a data printing diagram.

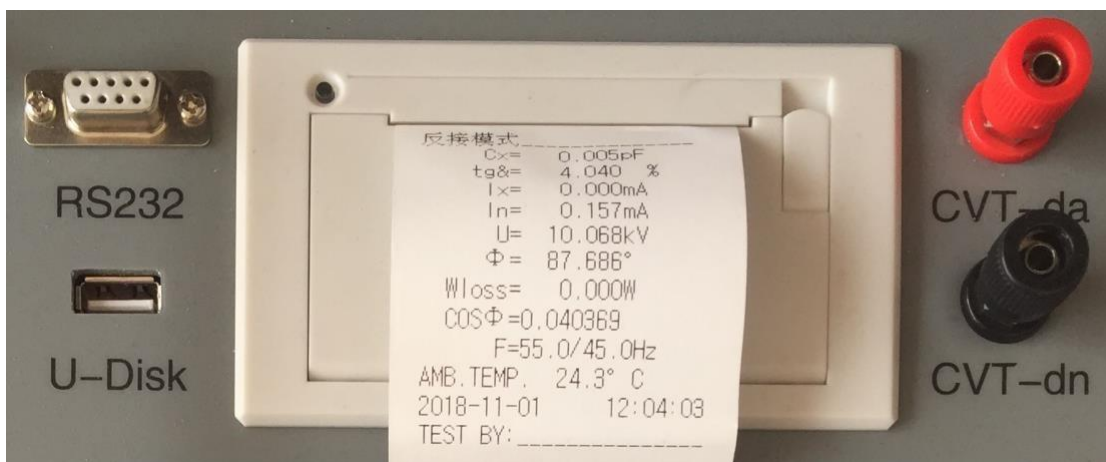

Figure 20 data printing diagram

3) The test. After printing or storing data, click the "exit" button with the touch pen or finger, and the device will return to the initial startup interface.

## **IX. Notes for Test**

If the test data is obviously unreasonable in use, please find out the reasons from the following aspects:

### **1. Poor contact of red clip on high voltage wire**

When the red clip is used to connect the sample in the field measurement, the red clip must be in good contact with the sample, otherwise the discharge of the contact point will cause serious fluctuation of the data. Especially the oxide layer of the drain line is too thick.

Please scrape the skin to avoid bad contact.

### **2. Poor grounding contact**

Poor grounding can cause serious fluctuation of instrument protection or data. The paint and rust on the grounding point should be scraped off, and zero resistance grounding must be guaranteed!

### **3. Direct Measurement of CVT or End Shielding Method for Measuring**

#### **Electromagnetic PT**

Direct measurement of the lower coupling capacitance of CVT will result in negative dielectric loss, so self-excitation method should be used instead.

When measuring electromagnetic PT with end shielding method, negative dielectric loss occurs due to "T-shaped network interference" caused by dampness. Blow-dry the three skirts of ceramic sleeve and terminal disc below. It can also be measured by conventional method or end pressure method.

### **4. Excessive air humidity**

Air humidity makes dielectric loss measurement abnormally increased (or decreased or even negative) and unstable, and shielding rings may be added when necessary. This method is controversial because the electric field distribution of the test sample is changed by artificial shielding ring. The relevant regulations can be consulted.

## **5. Generator Power Supply**

The output voltage of the generator is unstable when it is supplied with power, and there are high voltage burrs, which may lead to the wrong connection of 380V protection to start. Several power filters can be connected in series at the output end of the generator to solve this problem.

## **6. Test Line**

Because of long-term use, it is easy to cause hidden circuit break, short circuit of core wire and shield, or bad contact of plug. Users should always maintain the test line.

When testing standard capacitors, full shielded plugs should be used to eliminate the influence of additional stray capacitance, otherwise the accuracy of the instrument can not be reflected.

When measuring CVT by self-excitation method, the non-dedicated high-voltage line should be suspended, otherwise additional stray capacitance and dielectric loss to the ground will cause measurement errors.

## **7. Choice of working mode**

After wiring, please choose the correct measurement mode (positive, negative and CVT), not wrong. Especially in the interference environment, frequency conversion anti-jamming mode should be chosen.

## **8. Effect of test methods**

Because dielectric loss measurement is greatly influenced by test method, it should be distinguished between test method error and instrument error. When there is a problem, the wiring can be checked first, and then whether it is a fault of the instrument.

## **9. Instrument failure**

Use a multimeter to measure whether the test line is open, or whether the core line and shield are short-circuit; 220V input power supply is too high or too low; and whether the grounding is good.

Measure standard capacitors or capacitance samples with known capacitance and dielectric loss by positive and negative wiring. If the results are correct, it can be judged that there is no problem with the instrument.

## X. Discussion of Frequency Conversion Measurement

### 1. Frequency conversion measurement

When the interference is very serious, the frequency conversion measurement can get accurate and reliable results. For example, when measuring with 55Hz, the measuring system only allows 55Hz signal to pass, and 50Hz interference signal is effectively suppressed. The reason is that the measuring system can easily distinguish different frequencies. The following simple calculation can illustrate the effect of frequency selection measurement:

The sinusoidal waves with a difference of 1 times of the two frequencies are superimposed together, and the high-frequency ones are interference with a amplitude 10 times of the low-frequency ones:

$$Y=1.234\sin(x+5.678^\circ)+12.34\sin(2x+87.65^\circ)$$

At  $x=0/90/180/270^\circ$ , four measurements are obtained

$$Y_0=12.4517, Y_1= -11.1017, Y_2=12.2075, Y_3= -13.5576,$$

Calculate  $A=Y_1-Y_3=2.4559$ ,  $B=Y_0-Y_2=0.2442$ , then:

$$\varphi=\text{tg}^{-1}(B/A)=5.678^\circ \quad V=\sqrt{A^2+B^2}/2=1.234$$

This is just the phase and amplitude of the low frequency part, and the interference is suppressed. The measurement points of the actual waveform are up to tens of thousands, and the calculation is very large.

### 2. The relationship between frequency and dielectric loss

There are two ideal models of RC series and parallel dielectric losses: series model  $\text{tg}\delta=2\pi fRC$ , Parallel model  $\text{tg}\delta=1/(2\pi fRC)$ ,  $\text{tg}\delta$  is proportional and inverse with the frequency  $f$ . As shown in the figure,  $f$  has a great influence on the two models of perfect direct ratio and perfect inverse ratio. However, the actual capacitor is a hybrid model with many models interwoven, so the influence of  $f$  is small.

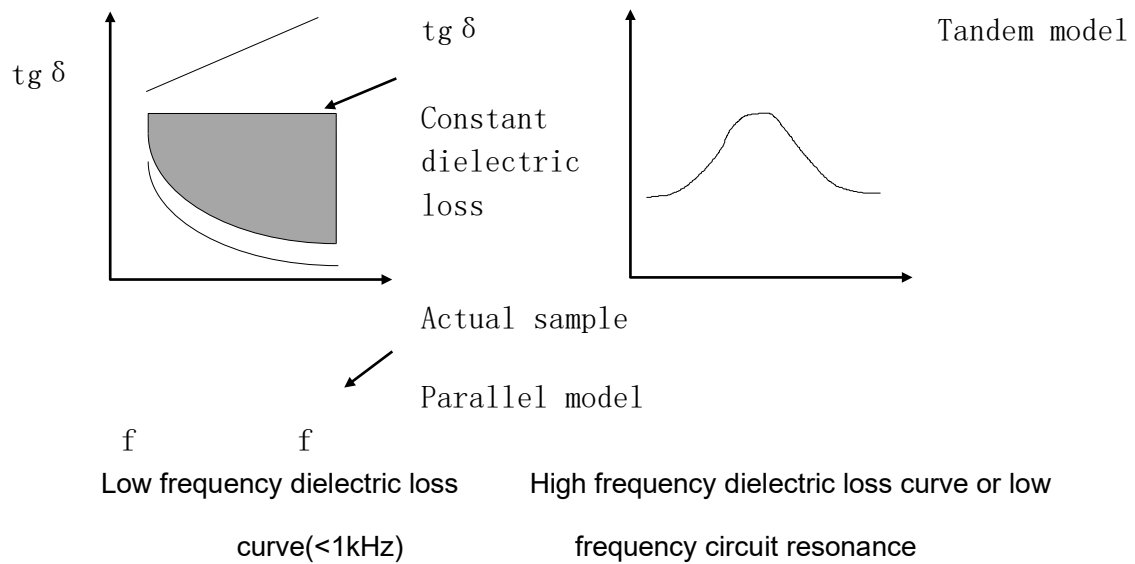

### 3、 Automatic frequency conversion is equivalent to 50Hz

The instrument adopts automatic frequency conversion to measure one point at each side of the interference frequency of 50Hz (45Hz and 55Hz), and then calculate the data at the frequency of 50Hz. In addition to the low frequency resonance of multiple component circuits, it is impossible for the medium in a single sample to cause the energy absorption peak at low frequency, and the dielectric loss near the power frequency always changes monotonously with the frequency. Therefore, this measurement method will not bring obvious errors. In fact, the average of the first two dielectric loss values is very close, even if the average is completely valuable. At present, frequency conversion dielectric loss instrument has become a conventional instrument for dielectric loss measurement, and its excellent anti-interference ability and accuracy have been recognized.

## XI.Packing List of Instrument

No.	Item	Qty
1	Power line	1
2	Ground lead	1
3	CVT Black test line	1
4	CVT Red test line	1
5	Print paper	1
6	Cx Cn cable	2
7	High voltage cable	1

Made in China

## FÖHR Group Electrical Measurement Equipment

MANUFACTURED BY H.E.M.B. CO.LTD

**CE/ISO/CNAS/IAF CERTIFIED**

info@fohrgroup.com

www.fohrgroup.com

### LEGAL DISCLAIMER AND LIMITATION OF LIABILITY

(Intellectual Property and Manufacturing Responsibility Statement) Effective Date: JANUARY 2025. This Legal Disclaimer and Limitation of Liability Statement ("Statement") is issued by FÖHR (the "Brand").

1. Manufacturing Structure. FÖHR is a commercial brand engaged in the marketing and distribution of electrical testing and industrial equipment. FÖHR does not design, engineer, develop, or manufacture the products directly. All products bearing the FÖHR brand name are manufactured, assembled, or produced by independent third-party original equipment manufacturers (OEMs) and contract manufacturers under private-label or contract manufacturing agreements. FÖHR operates solely as a brand owner and distributor.

2. No Ownership of Underlying Technology. FÖHR does not claim ownership of any underlying patents, utility models, industrial designs, trademarks, trade secrets, copyrights, proprietary software, firmware, embedded systems, or other intellectual property rights associated with the engineering or technological development of the products unless expressly stated in a separate written agreement. All intellectual property rights remain the sole responsibility of the respective manufacturers or lawful rights holders.

3. Intellectual Property Compliance Responsibility. Each independent manufacturer supplying products to FÖHR represents and warrants that: The products do not infringe any third-party patents, trademarks, copyrights, industrial designs, trade secrets, or other intellectual property rights. The products comply with applicable international intellectual property laws, including but not limited to: The TRIPS Agreement (WTO) The Paris Convention for the Protection of Industrial Property. The Berne Convention for the Protection of Literary and Artistic Works. Applicable national patent, trademark, and copyright laws in the jurisdictions where the products are manufactured or sold. FÖHR relies in good faith on such representations from its manufacturers.

4. Disclaimer of Liability for Intellectual Property Claims. To the fullest extent permitted by applicable law, FÖHR shall not be held liable for: Any alleged or actual patent infringement; Trademark violations; Copyright infringement; Misappropriation of trade secrets; Unauthorized use of proprietary technology; Design rights violations; Or any other intellectual property claim arising from the manufacture, design, engineering, or technological development of the products. Any claims relating to intellectual property infringement shall be directed exclusively to the original manufacturer responsible for the design and production of the goods.

5. No Independent Technology Development. FÖHR does not reverse engineer, modify core technologies, or alter proprietary engineering components supplied by its manufacturers. FÖHR does not independently develop internal circuitry, embedded firmware, measurement algorithms, or proprietary testing methodologies associated with the equipment.

6. Indemnification by Manufacturers. Manufacturers supplying products under the FÖHR brand are contractually required to indemnify, defend, and hold harmless FÖHR, its directors, officers, shareholders, affiliates, distributors, and agents from and against any claims, damages, liabilities, costs, or expenses arising from alleged intellectual property violations.

7. Jurisdictional Limitation. Nothing in this Statement shall exclude or limit liability where such exclusion is prohibited by mandatory law in any applicable jurisdiction. In jurisdictions where limitations of liability are restricted, FÖHR's liability shall be limited to the maximum extent permitted by law.

8. No Admission of Liability. This Statement does not constitute an admission of liability, infringement, wrongdoing, or legal responsibility of any kind.

9. Governing Law. This Statement shall be governed by and construed in accordance with the applicable commercial laws of the jurisdiction in which FÖHR is legally incorporated, without regard to conflict of law principles.