

SIMILAR SHAPES

Note that, for each of the following questions the diagrams are not accurately drawn.

- 1) The rhombuses shown below are mathematically similar. State the scale factor.



$$\text{Scale factor} = 12 \div 6 = 2$$

- 2) The triangles shown below are mathematically similar. State the scale factor.

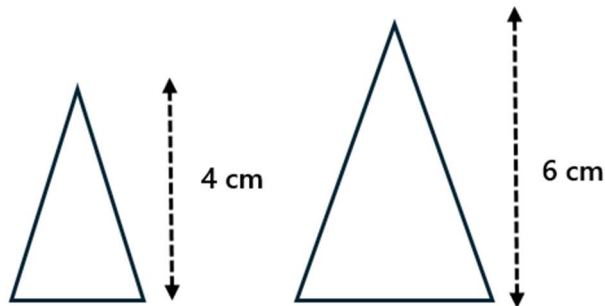

$$\text{Scale factor} = 6 \div 4 = 1.5$$

- 3) Two regular pentagons are shown below. State the scale factor.

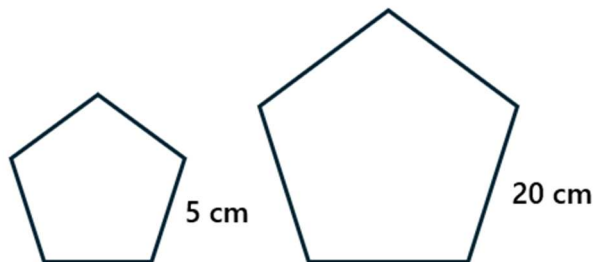

$$\text{Scale factor} = 20 \div 5 = 4$$

- 4) The rectangles shown below are mathematically similar. Work out the value of x .

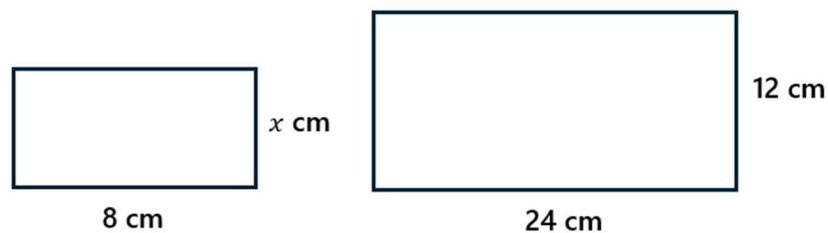

$$\text{Scale factor} = 24 \div 8 = 3$$

$$x = 12 \div 3 = 4$$

- 5) The parallelograms shown below are mathematically similar. Work out the value of x .



$$\text{Scale factor} = 18 \div 6 = 3$$

$$x = 9 \times 3 = 27$$

- 6) Two trapeziums are shown below. Determine if the shapes are mathematically similar. You must demonstrate all your working.

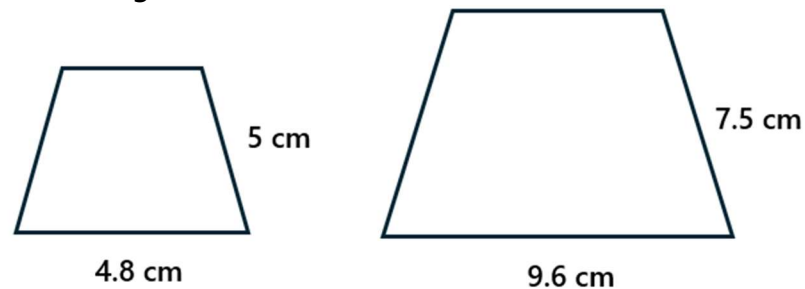

$$9.6 \div 4.8 = 2$$

$$7.5 \div 5 = 1.5$$

No, their corresponding sides have a different scale factor.

- 7) Two rectangles are shown below. Determine if the shapes are mathematically similar. You must demonstrate all your working.

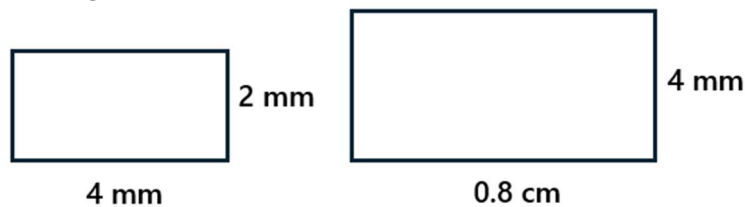

$$0.8 \text{ cm} = 8 \text{ mm}$$

$$8 \div 4 = 2$$

$$4 \div 2 = 2$$

Yes, the sides are enlarged by a scale factor of 2.

- 8) Two rectangles are shown below. Given that the rectangles are mathematically similar and the ratio $x : y = 1 : 3$, work out the value of z .

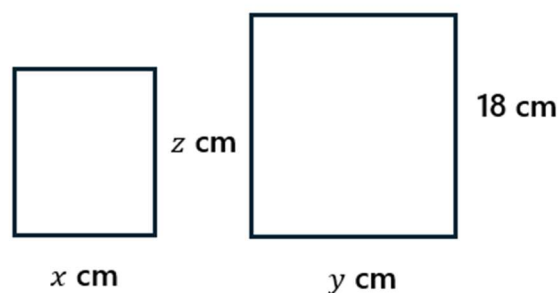

$$\text{Scale factor} = 3$$

$$z = 18 \div 3 = 6$$

9) AC is parallel to DE. ADB and CEB are straight lines.

AD = 10 cm

DB = 12.5 cm

DE = 5 cm

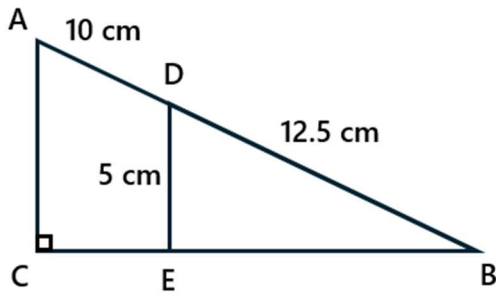

Work out the length of AC.

Draw the triangles separately

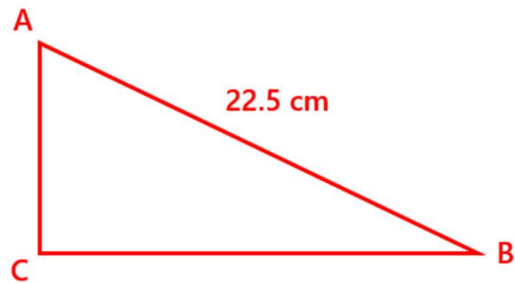
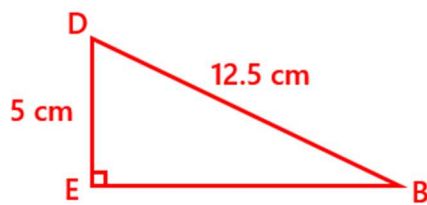

$$\text{Scale factor} = 22.5 \div 12.5 = 1.8$$
$$AC = 5 \times 1.8 = 9 \text{ cm}$$

10) QT is parallel to RS. PQR and PTS are straight lines.

$$PQ = 18 \text{ cm}$$

$$QR = 6 \text{ cm}$$

$$PT = 16.2 \text{ cm}$$

$$RS = 16 \text{ cm}$$

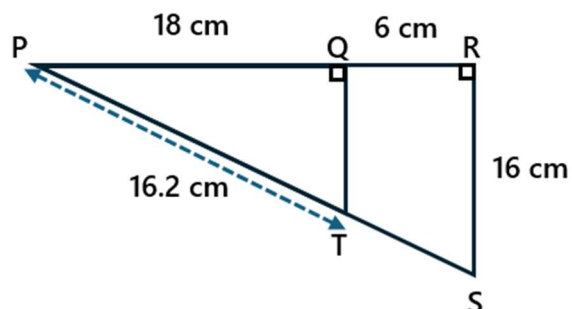

a. Work out the length of QT.

Draw the triangles separately

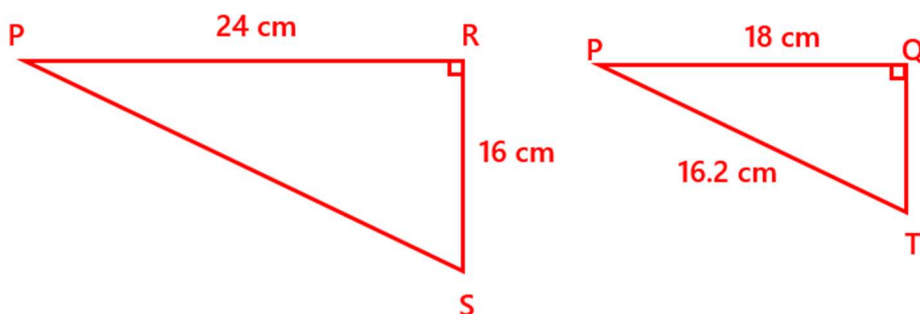

$$\text{Scale factor} = 24 \div 18 = \frac{4}{3}$$

$$QT = 16 \div \frac{4}{3} = 12 \text{ cm}$$

b. Work out the length of TS.

$$PS = 16.2 \times \frac{4}{3} = 21.6$$

$$TS = 21.6 - 16.2 = 5.4 \text{ cm}$$

- 11) AB is parallel to CD.
 AD and BC bisect at E.
 AB = 8 cm
 CD = 20 cm
 ED = 18 cm

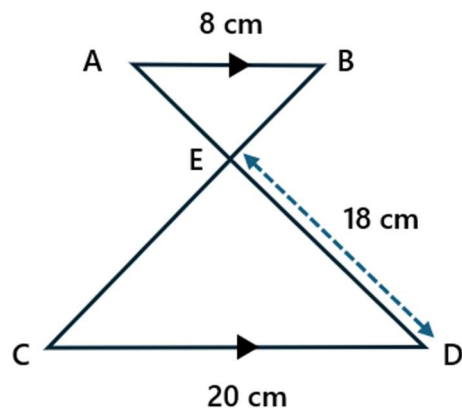

Work out the length of AE.

Draw the triangles separately

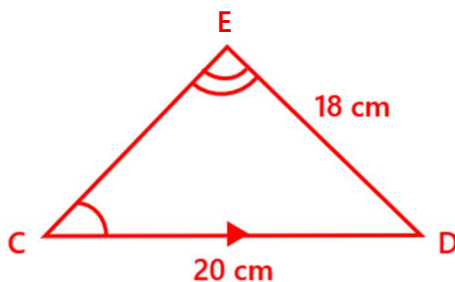
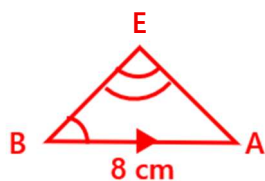

$$\text{Scale factor} = 20 \div 8 = 2.5$$

$$AE = 18 \div 2.5 = 7.2 \text{ cm}$$

12) NQ is parallel to OP. MNO and MQP are straight lines.

$$MN = 12 \text{ cm}$$

$$NO = 6 \text{ cm}$$

$$MQ = 10.5 \text{ cm}$$

$$OP = 9 \text{ cm}$$

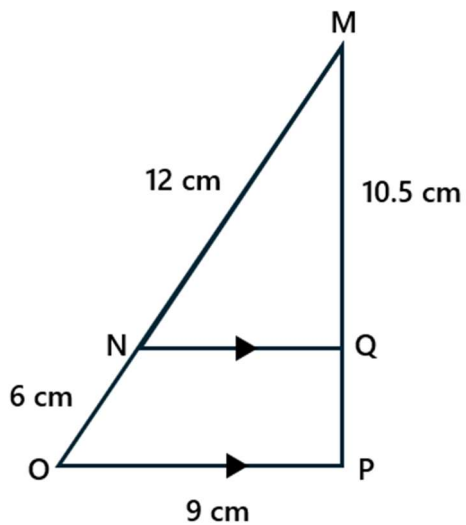

a. Work out the length of MP.

Draw the triangles separately

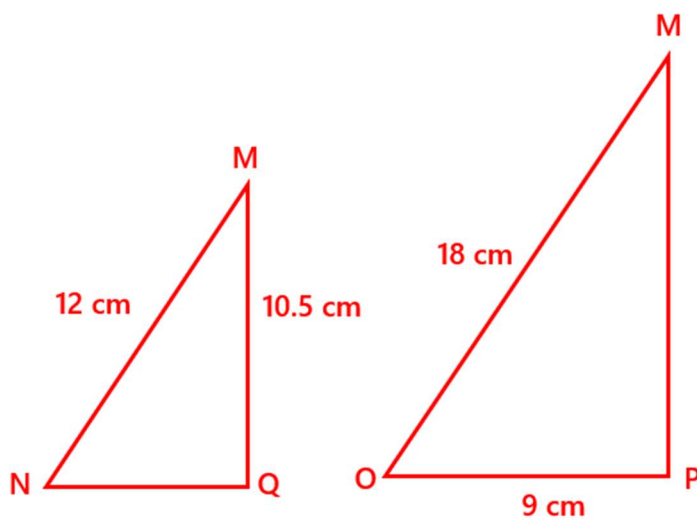

$$\text{Scale factor} = 18 \div 12 = 1.5$$

$$MP = 10.5 \times 1.5 = 15.75 \text{ cm}$$

b. Work out the length of NQ.

$$NQ = 9 \div 1.5 = 6 \text{ cm}$$

- 13) AB is parallel to CD.
 AD and BC bisect at E.
 AB = 6 cm
 AE = 4 cm
 ED = 12 cm

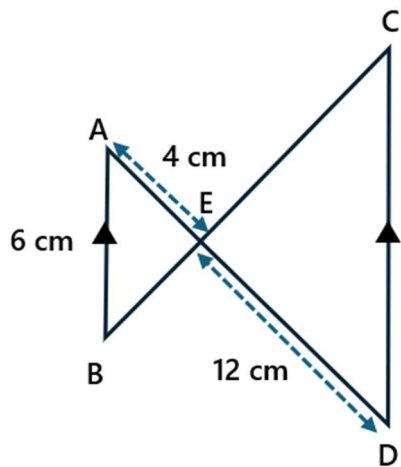

- a. Work out the length of CD.

Draw the triangles separately

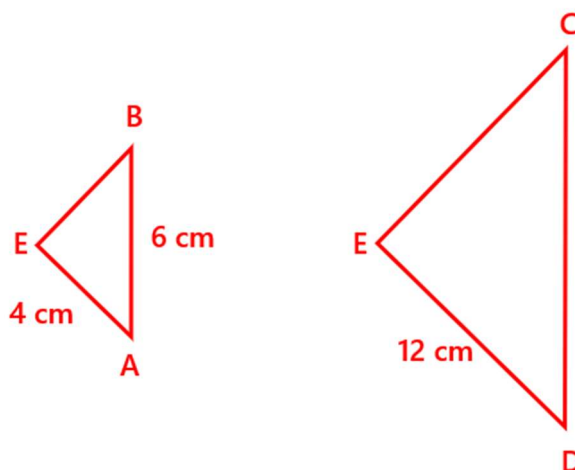

$$\text{Scale factor} = 12 \div 4 = 3$$

$$CD = 6 \times 3 = \mathbf{18 \text{ cm}}$$

- b. Given that the sum of BE and CE is 12 cm, work out the length of BE.

$$BE = x$$

$$EC = 3x$$

$$x + 3x = 12$$

$$4x = 12$$

$$x = \mathbf{3 \text{ cm}}$$

14) The triangles FEG and HIJ are mathematically similar.

Given that $FG : HJ = 1 : 2$, work out the value of x .

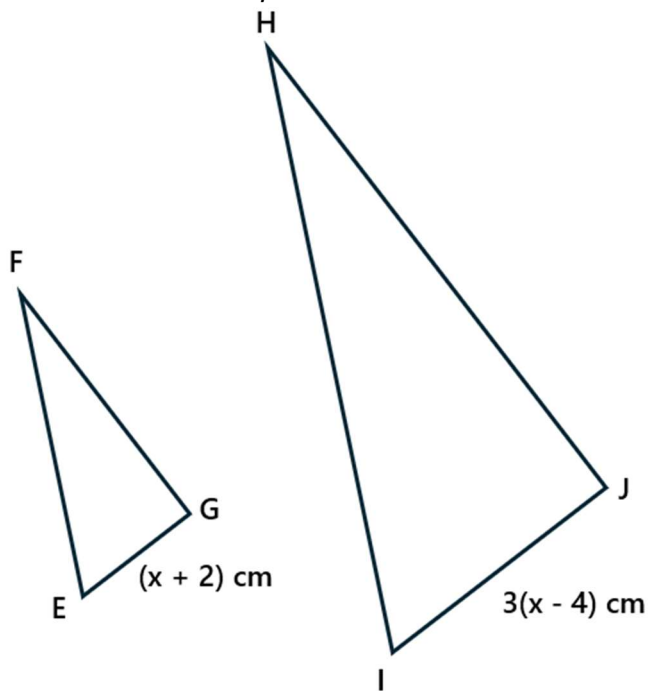

Scale factor is 2

$$2 \times EG = IJ$$

$$2(x + 2) = 3(x - 4)$$

$$2x + 4 = 3x - 12$$

$$x = 16 \text{ cm}$$

15) The trapeziums ABCD and EFGH are mathematically similar.

Given that $AB : EF = 2 : 3$, work out the value of x .

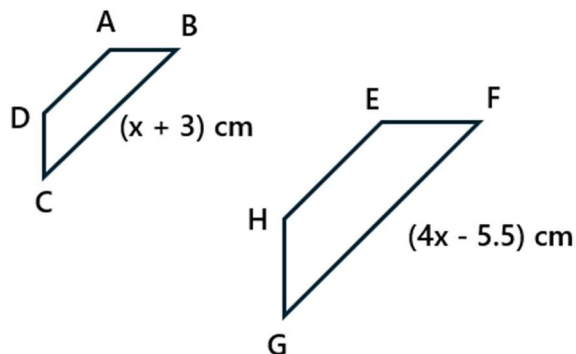

$$2 : 3$$

$$1 : 1.5$$

Scale factor is 1.5

$$1.5 \times BC = GH$$

$$1.5(x + 3) = 4x - 5.5$$

$$1.5x + 4.5 = 4x - 5.5$$

$$2.5x = 10$$

$$x = 4 \text{ cm}$$

16) The lines RT and UV are parallel.

$$US = 8 \text{ cm}$$

$$RT = 16.8 \text{ cm}$$

$$UV = 12 \text{ cm}$$

$$SV = x \text{ cm}$$

$$VT = 2.4 \text{ cm}$$

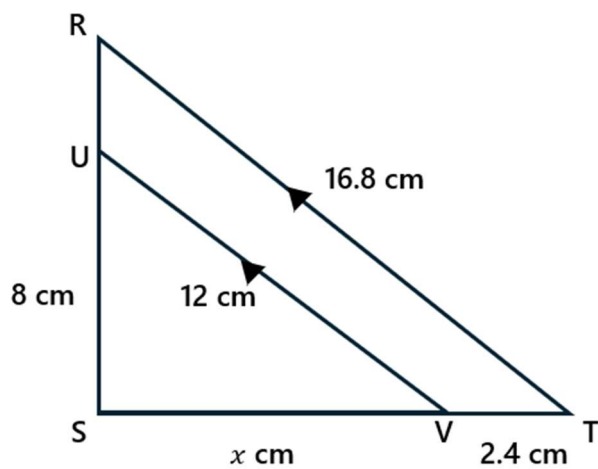

a. Work out the length of RS.

Draw the triangles separately

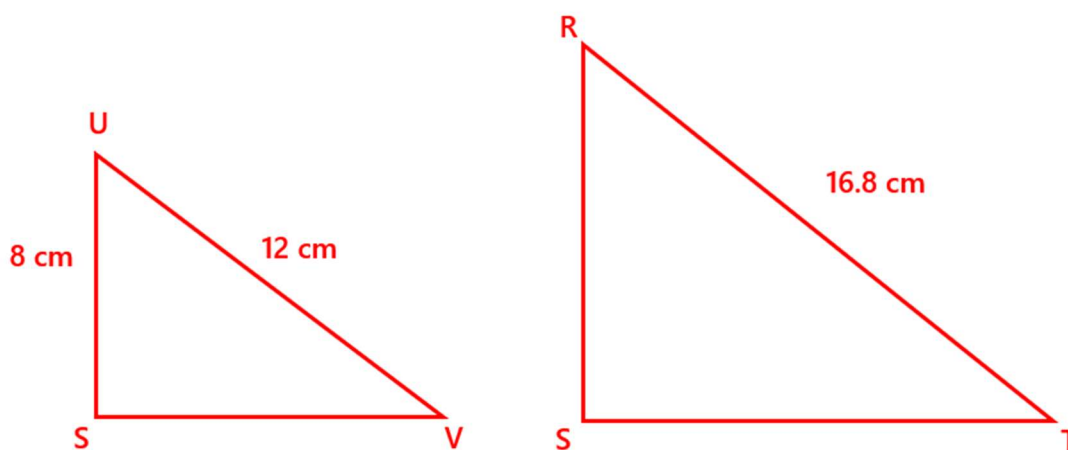

$$\text{Scale factor} = 16.8 \div 12 = 1.4$$

$$RS = 8 \times 1.4 = \mathbf{11.2 \text{ cm}}$$

b. Work out the length of SV.

$$1.4 \times SV = ST$$

$$1.4x = x + 2.4$$

$$0.4x = 2.4$$

$$x = \mathbf{6 \text{ cm}}$$

Challenge

17) ABCD and AGFE are straight lines.

BG is parallel to CF.

CF is parallel to DE.

$AG : AF : AE = 1 : 2 : 3$

$AG = 7.5x \text{ cm}$

$GF = (6x + 1.8) \text{ cm}$

$BC = 9x \text{ cm}$

$DE = (20x - 2) \text{ cm}$

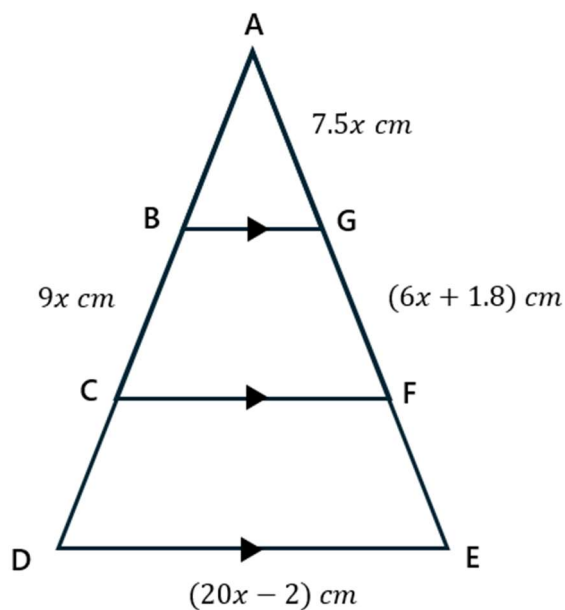

a. Work out the length of AC.

Draw the triangles separately

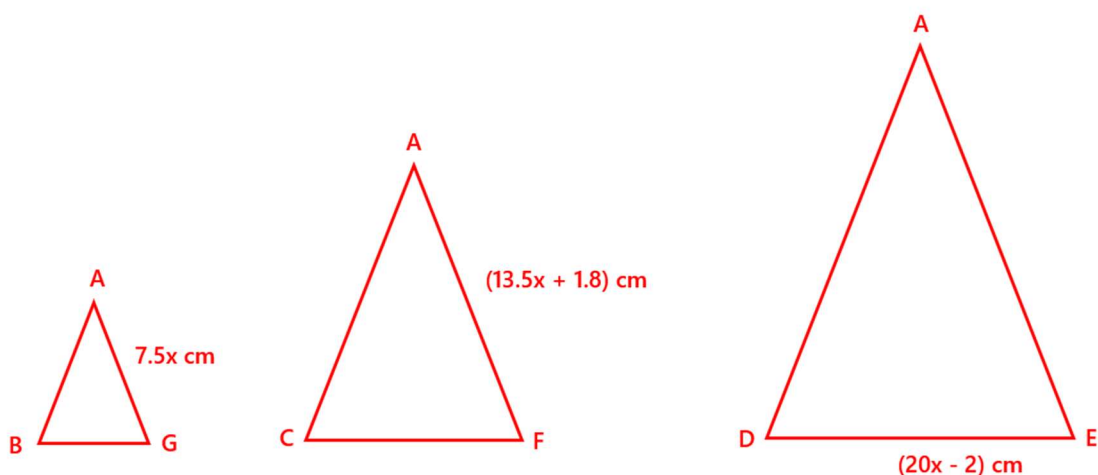

$$\begin{aligned}
 2 \times AG &= AF \\
 2(7.5x) &= 7.5x + 6x + 1.8 \\
 15x &= 13.5x + 1.8 \\
 1.5x &= 1.8 \\
 x &= 1.2
 \end{aligned}$$

$$\begin{aligned}
 BC &= 9 \times 1.2 = 10.8 \text{ cm} \\
 AC &= 10.8 \times 2 = \mathbf{21.6 \text{ cm}}
 \end{aligned}$$

b. Work out the length of CF. Give your answer to 3 significant figures.

$$\begin{aligned}
 DE &= 20(1.2) - 2 = 22 \text{ cm} \\
 BG &= 22 \div 3 = \frac{22}{3} \\
 CF &= \frac{22}{3} \times 2 = \mathbf{14.7 \text{ cm (3 sf)}}
 \end{aligned}$$

18) The two rectangles shown below are mathematically similar. Given that the ratio $CD : GH = 1 : 3$, write an algebraic expression for y in terms of z .

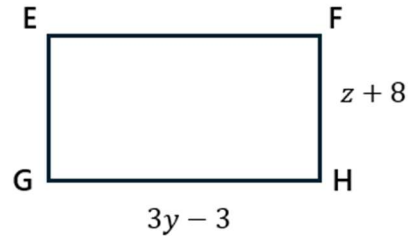
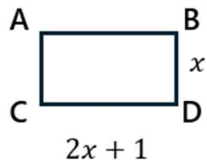

Scale factor is 3

$$3 \times CD = GH$$

$$3(2x + 1) = 3y - 3$$

$$6x + 3 = 3y - 3$$

$$6x = 3y - 6$$

$$x = \frac{y}{2} - 1$$

$$3 \times BD = FH$$

$$3x = z + 8$$

$$3\left(\frac{y}{2} - 1\right) = z + 8$$

$$\frac{3y}{2} - 3 = z + 8$$

$$\frac{3y}{2} = z + 11$$

$$3y = 2z + 22$$

$$y = \frac{2z}{3} + \frac{22}{3}$$