

# SURFACE AREA OF PRISMS

- 1) Work out the total surface area of the cuboid shown below.

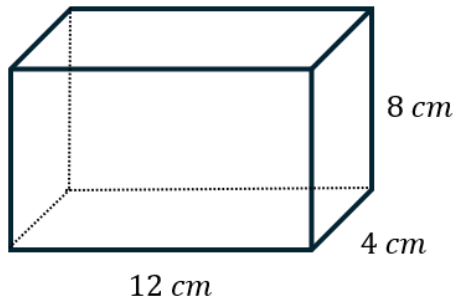

**Front/back:**  $2 \times (12 \times 8) = 192 \text{ cm}^2$

**Sides:**  $2 \times (8 \times 4) = 64 \text{ cm}^2$

**Top/bottom:**  $2 \times (12 \times 4) = 96 \text{ cm}^2$

**Surface area** =  $192 + 64 + 96 = 352 \text{ cm}^2$

- 2) Work out the total surface area of the cuboid shown below.

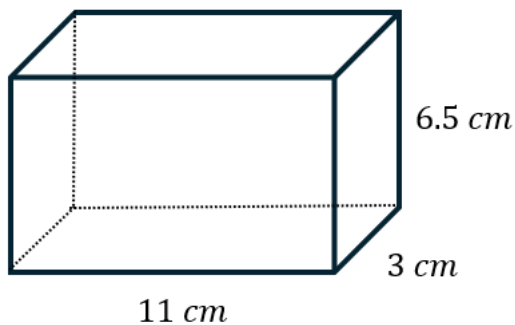

**Front/back:**  $2 \times (11 \times 6.5) = 143 \text{ cm}^2$

**Sides:**  $2 \times (6.5 \times 3) = 39 \text{ cm}^2$

**Top/bottom:**  $2 \times (11 \times 3) = 66 \text{ cm}^2$

**Surface area** =  $143 + 39 + 66 = 248 \text{ cm}^2$

- 3) A cube has a volume of  $125 \text{ cm}^3$ . Work out the total surface area of the cube.

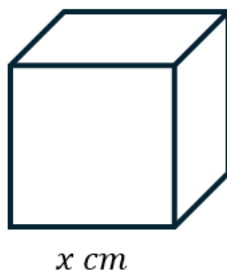

**Side length** =  $\sqrt[3]{125} = 5 \text{ cm}$

**Surface area** =  $6 \times (5 \times 5) = 150 \text{ cm}^2$

- 4) Given that the surface area of the cuboid shown in the diagram is  $248 \text{ mm}^2$ , work out the value of  $x$ .

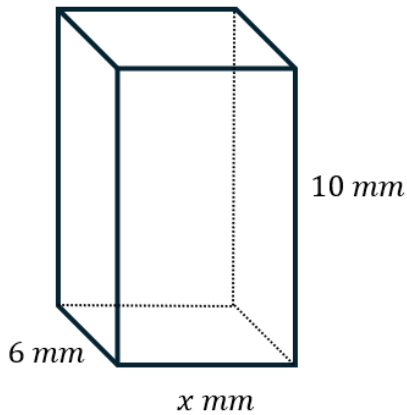

**Front/back:**  $2 \times (10 \times x) = 20x \text{ mm}^2$

**Sides:**  $2 \times (10 \times 6) = 120 \text{ mm}^2$

**Top/bottom:**  $2 \times (6 \times x) = 12x \text{ mm}^2$

$$20x + 120 + 12x = 248$$

$$32x + 120 = 248$$

$$32x = 128$$

$$x = 4$$

- 5) The cross section of the prism shown below is a right-angled triangle. Work out the total surface area of the triangular prism.

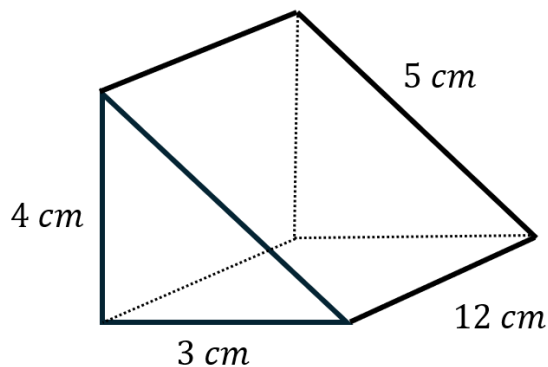

**Triangles:**  $2 \times \left(\frac{4 \times 3}{2}\right) = 12 \text{ cm}^2$

**Bottom:**  $12 \times 3 = 36 \text{ cm}^2$

**Left side:**  $4 \times 12 = 48 \text{ cm}^2$

**Top:**  $5 \times 12 = 60 \text{ cm}^2$

**Surface area** =  $12 + 36 + 48 + 60 = 156 \text{ cm}^2$

- 6) The dimensions of a triangular prism are as shown in the diagram. Work out the total surface area of the triangular prism.

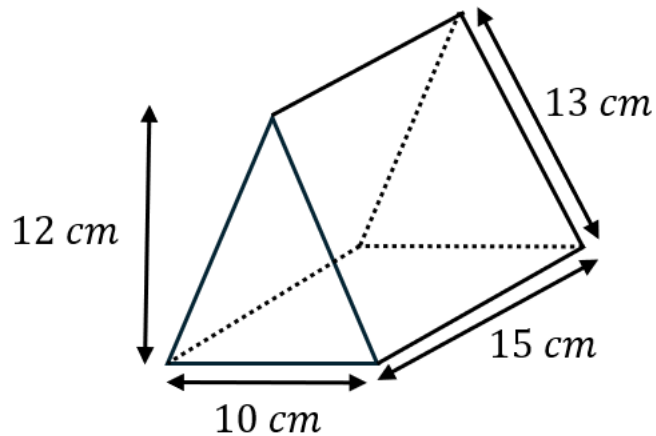

**Triangles:**  $2 \times \left( \frac{10 \times 12}{2} \right) = 120 \text{ cm}^2$

**Bottom:**  $10 \times 15 = 150 \text{ cm}^2$

**Sides:**  $2 \times (13 \times 15) = 390 \text{ cm}^2$

**Surface area** =  $120 + 150 + 390 = 660 \text{ cm}^2$

- 7) The cross section of the triangular prism is a right-angled triangle. Given that the total surface area of the prism is  $120 \text{ cm}^2$ , work out the value of  $x$ .

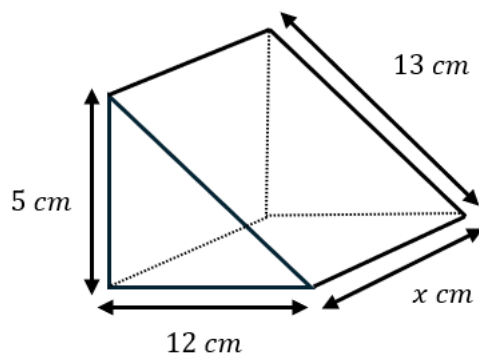

**Triangles:**  $2 \times \left( \frac{5 \times 12}{2} \right) = 60 \text{ cm}^2$

**Bottom:**  $12 \times x = 12x \text{ cm}^2$

**Left side:**  $5 \times x = 5x \text{ cm}^2$

**Top:**  $13 \times x = 13x \text{ cm}^2$

$$60 + 12x + 5x + 13x = 120$$

$$30x + 60 = 120$$

$$30x = 60$$

$$x = 2$$

- 8) The cross section of the prism shown below is a trapezium. Work out the total surface area of the prism.

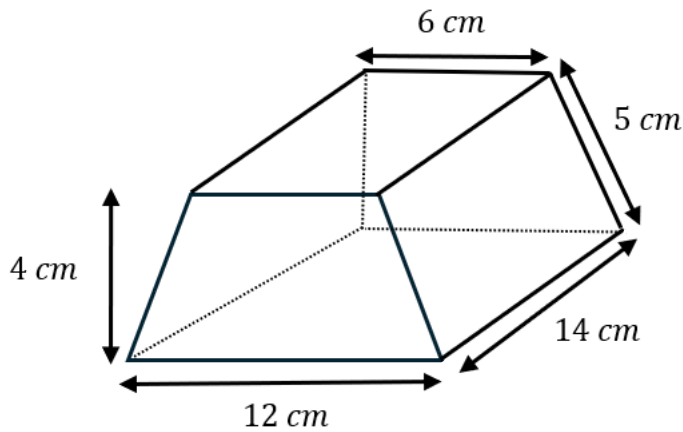

**Two trapeziums:**  $2 \times \left( \frac{1}{2} \times (6 + 12) \times 4 \right) = 72 \text{ cm}^2$

**Bottom:**  $12 \times 14 = 168 \text{ cm}^2$

**Sides:**  $2 \times (14 \times 5) = 140 \text{ cm}^2$

**Top:**  $6 \times 14 = 84 \text{ cm}^2$

**Surface area** =  $72 + 168 + 140 + 84 = 464 \text{ cm}^2$

- 9) The cylinder shown below has a radius of 4 cm and a height of 8 cm. Work out the total surface area of the cylinder. Give your answer to 2 decimal places.

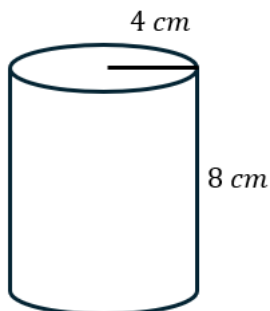

**Two circles:**  $2 \times (\pi \times 4^2) = 32\pi \text{ cm}^2$

**Curved surface area:**  $8 \times (2 \times \pi \times 4) = 64\pi \text{ cm}^2$

**Surface area** =  $32\pi + 64\pi$   
 $= 96\pi$   
 $= 301.5928 \dots$   
 $= 301.59 \text{ cm}^2$

- 10) The cylinder shown below has a diameter of 12 cm and a height of 16 cm. Work out the total surface area of the cylinder. Give your answer in terms of  $\pi$ .

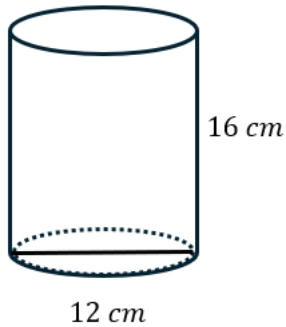

**Radius = 6 cm**

**Two circles:**  $2 \times (\pi \times 6^2) = 72\pi \text{ cm}^2$

**Curved surface area:**  $16 \times (2 \times \pi \times 6) = 192\pi \text{ cm}^2$

**Surface area =  $72\pi + 192\pi = 264\pi \text{ cm}^2$**

- 11) A carpenter is building a wooden storage crate shaped like a triangular prism. The dimensions of the crate are shown below. The entire inside and outside surface of the crate will be painted.

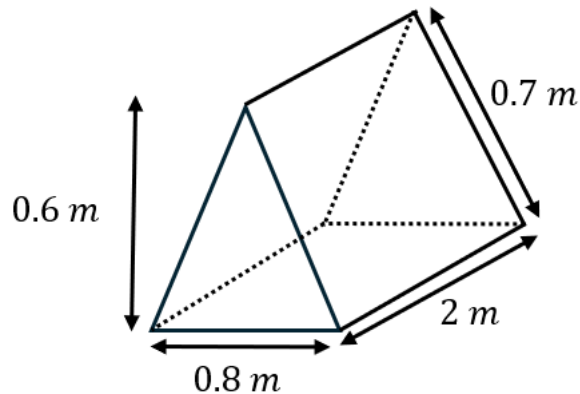

A tin of paint covers  $3 \text{ m}^2$  and costs £18 per tin.

Work out the total cost of the paint.

You must show all your working.

**Area of two triangles:**  $2 \times \left(\frac{0.8 \times 0.6}{2}\right) = 0.48 \text{ m}^2$

**Bottom:**  $0.8 \times 2 = 1.6 \text{ m}^2$

**Sides:**  $2 \times (2 \times 0.7) = 2.8 \text{ m}^2$

**Surface area of inside and outside =  $2 \times (0.48 + 1.6 + 2.8) = 9.76 \text{ m}^2$**

**Paint tins needed:**

$9.76 \div 3 = 3.253 \dots$

**Therefore, 4 tins are needed.**

**$4 \times £18 = £72$**

- 12) A company is wrapping a large gift box shaped like a cuboid for a shop display. The measurements of the box are shown in the diagram below.

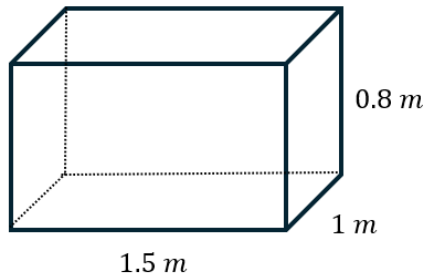

Wrapping paper costs £4 per square metre.

Given that, 10% extra paper is needed for overlaps and mistakes, work out the total cost of the wrapping paper.

**Front/back:**  $2 \times (1.5 \times 0.8) = 2.4 \text{ m}^2$

**Sides:**  $2 \times (0.8 \times 1) = 1.6 \text{ m}^2$

**Top/bottom:**  $2 \times (1.5 \times 1) = 3 \text{ m}^2$

**Surface area** =  $2.4 + 1.6 + 3 = 7 \text{ m}^2$

**Including 10% extra:**

$7 \times 1.1 = 7.7 \text{ m}^2$

**Total cost:**

$7.7 \times 4 = \text{£}30.80$

- 13) Six small storage containers are going to be painted. The dimensions of the containers are shown in the diagram below.

One tin of paint can cover  $0.5 \text{ m}^2$ .

Given that each container will be given two coats of paint, work out the number of tins of paint needed. You must demonstrate all your working.

**Front/back:**  $2 \times (50 \times 30) = 3000 \text{ cm}^2$

**Sides:**  $2 \times (30 \times 40) = 2400 \text{ cm}^2$

**Top/bottom:**  $2 \times (50 \times 40) = 4000 \text{ cm}^2$

**Surface area** =  $3000 + 2400 + 4000 = 9400 \text{ cm}^2$

$1 \text{ cm} = 0.01 \text{ m}$

$9400 \times 0.01^2 = 0.94 \text{ m}^2$

**Two coats for six containers:**

$0.94 \times 2 \times 6 = 11.28 \text{ m}^2$

$11.28 \div 0.5 = 22.56$

**23 tins of paint are needed.**

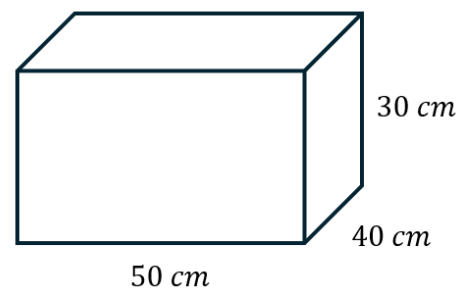

14) Work out the total surface area of the L-shaped prism shown below.

Left side:  $12 \times 4 = 48 \text{ m}^2$

Top left:  $3 \times 12 = 36 \text{ m}^2$

Top right:  $8 \times 12 = 96 \text{ m}^2$

Upper right side:  $2 \times 12 = 24 \text{ m}^2$

Lower right side:  $2 \times 12 = 24 \text{ m}^2$

Bottom:  $11 \times 12 = 132 \text{ m}^2$

Front:  $(4 \times 3) + (8 \times 2) = 28 \text{ m}^2$

Back:  $(4 \times 3) + (8 \times 2) = 28 \text{ m}^2$

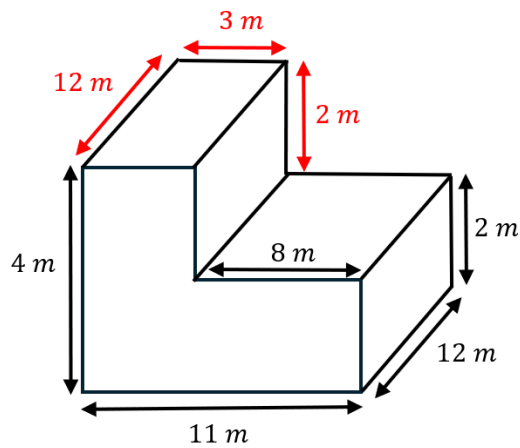

Total surface area =  $48 + 36 + 96 + 24 + 24 + 132 + 28 + 28 = 416 \text{ m}^2$

### Challenge

15) The cuboid shown in the diagram has a length of  $(x + 2)$  cm, a width of  $(x - 1)$  cm and a height of  $x$  cm.

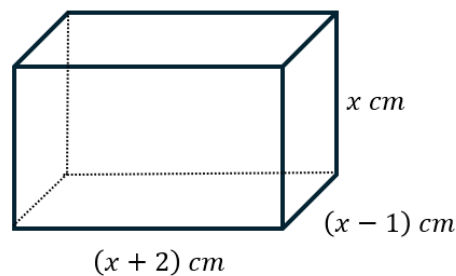

Given that the surface area of the cuboid is  $214 \text{ cm}^2$ , show that  $3x^2 + 2x - 109 = 0$ .

#### Area

Top/bottom:  $2(x + 2)(x - 1)$   
 $= 2(x^2 - x + 2x - 2)$   
 $= 2(x^2 + x - 2)$   
 $= 2x^2 + 2x - 4$

Sides:  $2x(x - 1)$   
 $= 2x^2 - 2x$

Front/back:  $2x(x + 2)$   
 $= 2x^2 + 4x$

#### Surface area

$2x^2 + 2x - 4 + 2x^2 - 2x + 2x^2 + 4x = 214$

$6x^2 + 4x - 4 = 214$

$6x^2 + 4x - 218 = 0$

$3x^2 + 2x - 109 = 0$

- 16) A solid tunnel-shaped block is made from a half cylinder placed on top of a rectangular base. The half cylinder has a radius of  $x$  cm and length  $(3x + 2)$  cm.

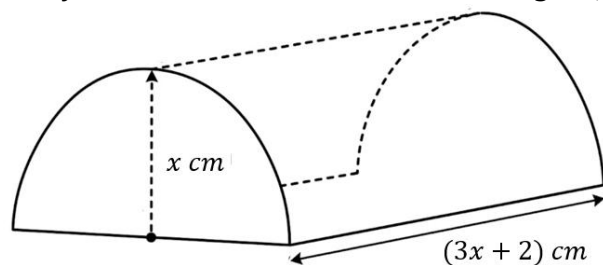

Show that the total surface area of the solid can be written in the form  $a\pi x^2 + b\pi x + cx^2 + dx$ , where  $a, b, c$  and  $d$  are constants to be found.

Surface area of two semi-circular ends:

$$2 \times \left( \frac{1}{2} \times \pi \times x^2 \right) = \pi x^2$$

Curved surface area of the half cylinder:

$$\begin{aligned} & \frac{1}{2} \times (2 \times \pi \times x) \times (3x + 2) \\ &= \pi x(3x + 2) \\ &= 3\pi x^2 + 2\pi x \end{aligned}$$

Surface area of rectangular base:

$$2x(3x + 2) = 6x^2 + 4x$$

Total surface area:

$$\begin{aligned} & \pi x^2 + 3\pi x^2 + 2\pi x + 6x^2 + 4x \\ &= 4\pi x^2 + 2\pi x + 6x^2 + 4x \end{aligned}$$

$$\therefore a = 4, \quad b = 2, \quad c = 6, \quad d = 4$$