

VOLUME OF FRUSTUMS

- 1) The diagram shows the frustum formed from a square-based pyramid. Calculate the volume of the frustum.

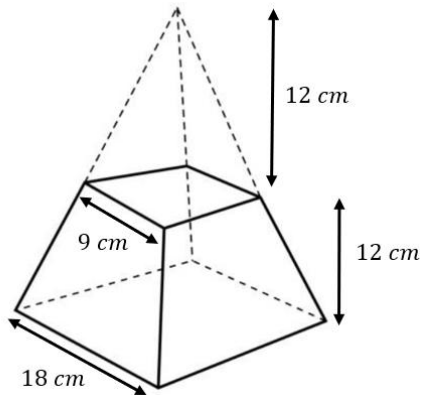

- 2) The diagram shows the frustum formed from a square-based pyramid. Calculate the volume of the frustum. Give your answer to 3 significant figures.

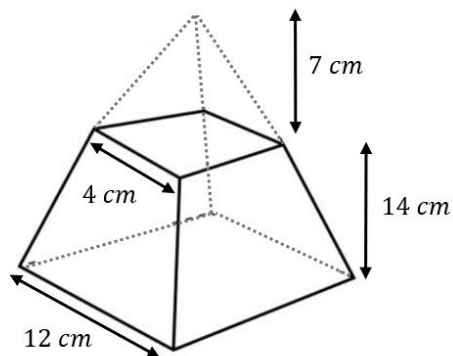

- 3) A square-based pyramid has a height of 20 cm and a base side length of 16 cm. The top 5 cm of the pyramid is removed parallel to the base. Calculate the volume of the frustum.

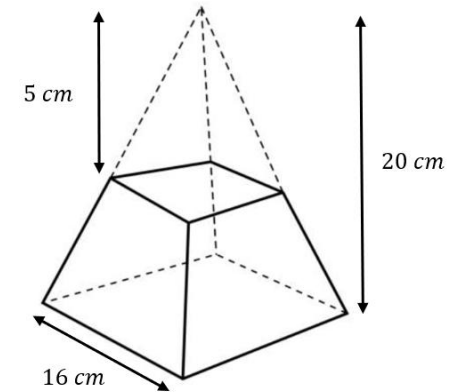

- 4) A square-based pyramid has a height of 24 cm and a base side length of 40 cm. The top of the pyramid is removed parallel to the base and has a base side length of 30 cm. Calculate the volume of the frustum.

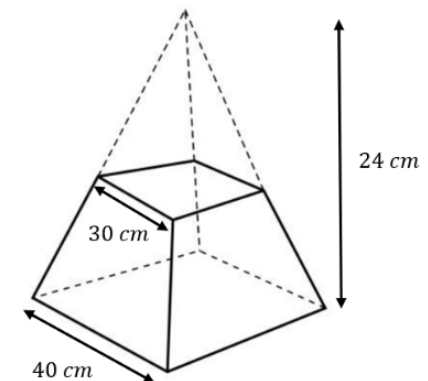

- 5) A cone has a height of 14 cm and a radius of 10 cm. The frustum of a cone is formed by removing a smaller cone, parallel to the base. The smaller cone has a height of 5.6 cm and a radius of 4 cm. Calculate the volume of the frustum. Give your answer to 1 decimal place.

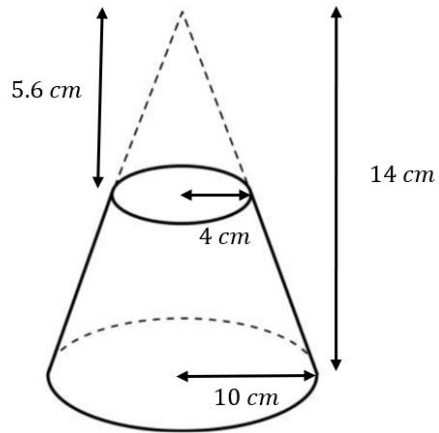

- 6) The diagram shows the frustum formed from a cone. Calculate the volume of the frustum. Give your answer in terms of π .

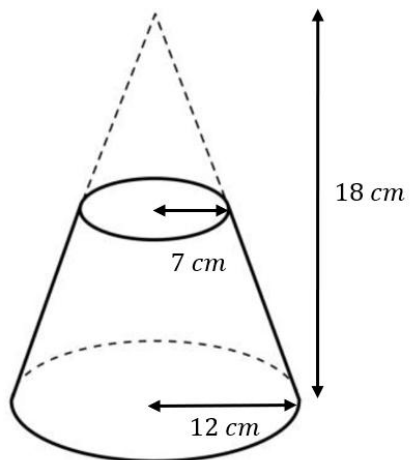

- 7) A cone has a height of 30 cm and a base radius of 12 cm. The top 10 cm of the cone is removed. Calculate the volume of the remaining frustum. Give your answer to the nearest cubic centimetre.

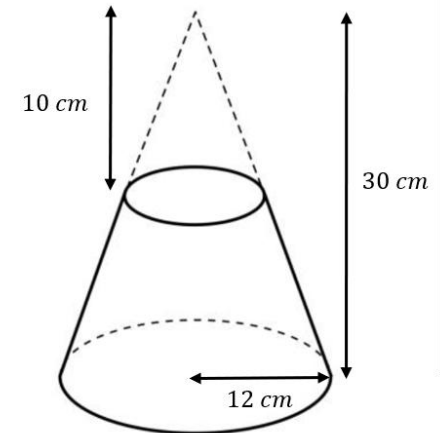

- 8) A cone has a height of 40 mm and a base radius of 15 mm. The remaining frustum has a height of 25 mm as shown in the diagram. Calculate the volume of the frustum. Give your answer to the nearest cubic millimetre.

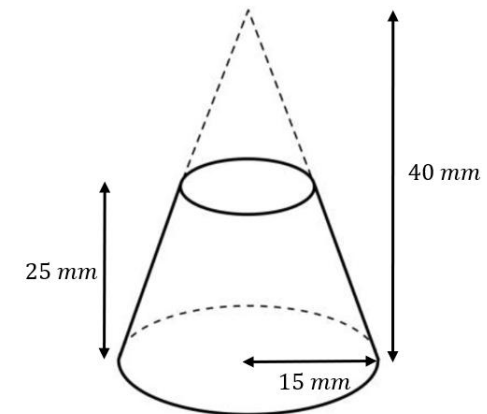

- 9) A cone has a diameter of 10 cm and a slant height of 13 cm. A frustum of a cone is formed by removing a smaller cone, parallel to the base. The smaller cone has a diameter of 8 cm. Work out the volume of the frustum. Give your answer to 2 decimal places.

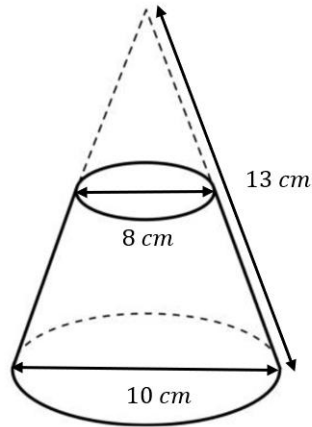

- 10) A frustum of a square-based pyramid has a height of 10 cm, a top side length of x cm and a bottom side length of $2x$ cm. The volume of the frustum is 3500 cm^3 . Work out the value of x . Give your answer to 1 decimal place.

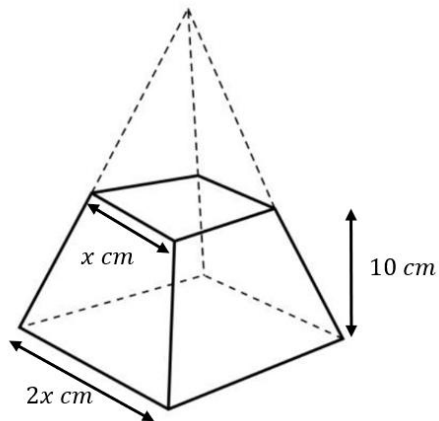

Challenge

- 11) A square-based pyramid has height h cm and base side length $(2a)$ cm. The top half of the pyramid is removed by a plane parallel to the base. Show that the volume of the remaining frustum is $\frac{7}{6}a^2h \text{ cm}^3$.

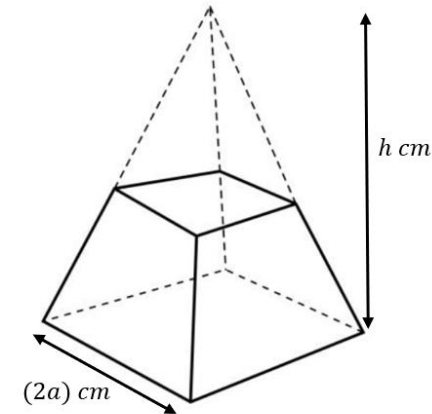

- 12) A cone has a height of $3h$ and a radius of $2r$. The top cone removed has a height of h . Work out the volume of the frustum. Give your answer in terms of π , r and h .

