

VOLUME OF COMPLEX SHAPES

- 1) The sphere shown in the diagram has a radius of 4 cm. Work out the volume of the sphere. Give your answer to 2 decimal places.

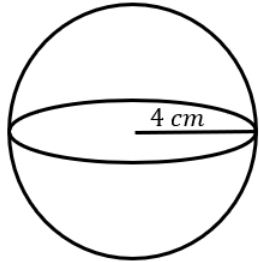

- 2) The sphere shown in the diagram has a diameter of 10 cm. Work out the volume of the sphere. Give your answer to 2 decimal places.

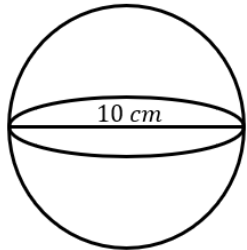

- 3) The cone shown in the diagram has a radius of 3 cm and a perpendicular height of 8 cm. Work out the volume of the cone. Give your answer to 1 decimal place.

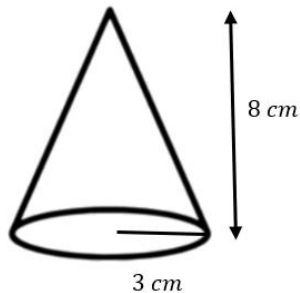

- 4) The cone shown in the diagram has a diameter of 9 cm and a height of 11 cm. Work out the volume of the cone. Give your answer in terms of π .

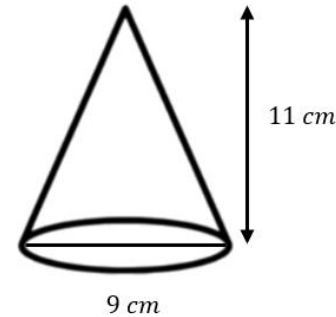

- 5) A square-based pyramid is shown in the diagram. Work out the volume of the pyramid.

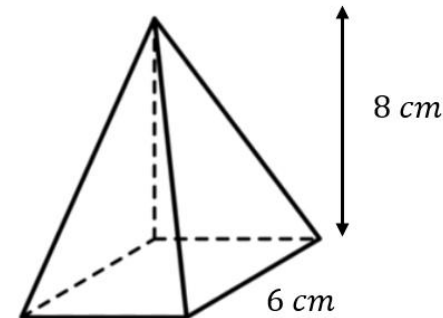

- 6) The dimensions of a square-based pyramid are shown in the diagram below. Work out the volume of the pyramid.

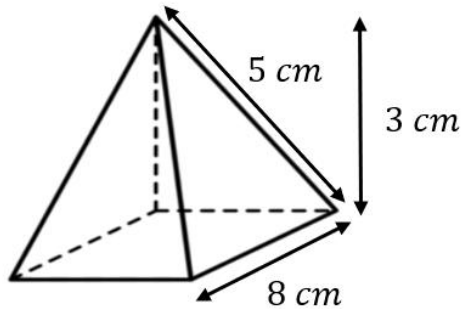

- 7) The hemisphere shown in the diagram has a radius of 5 cm . Work out the volume of the hemisphere. Give your answer in terms of π .

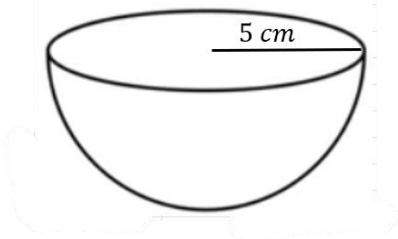

- 8) The cone shown in the diagram below has a radius of 4 cm and a volume of 100.5 cm^3 . Work out the value of h . Give your answer to the nearest unit.

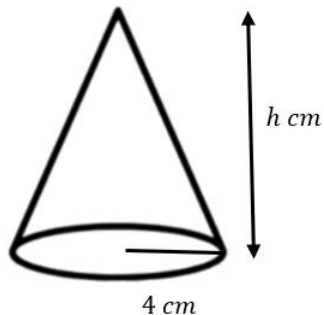

- 9) The sphere shown in the diagram below has a volume of $288\pi\text{ cm}^3$. Work out the missing radius.

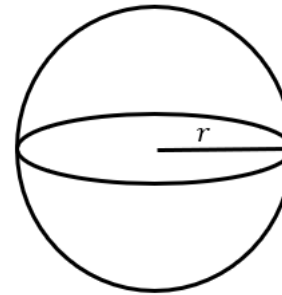

- 10) A cone is shown in the diagram below. The cone has a diameter of 10 cm and a slant height of 13 cm . Work out the volume of the cone. Give your answer to 3 significant figures.

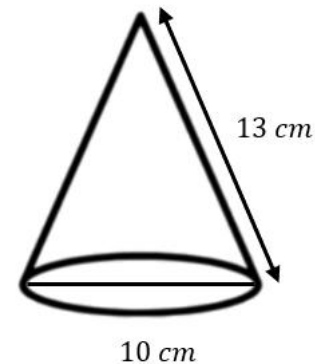

- 11) A solid consists of a hemisphere of radius 3 cm joined to a cone with radius 3 cm and height 8 cm. Work out the total volume of the solid. Give your answer to 3 significant figures.

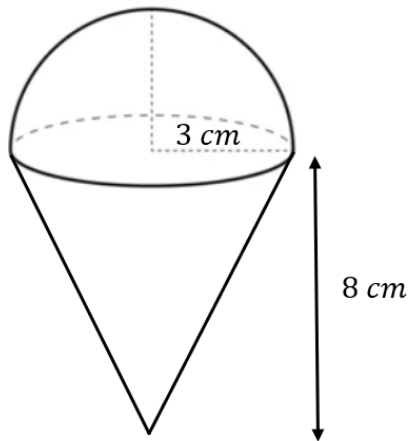

- 12) A conical container has radius 5 cm and height 15 cm. Water is poured in at a rate of 20 cm^3 per second. How long does it take to fill the cone completely? Give your answer to the nearest second.

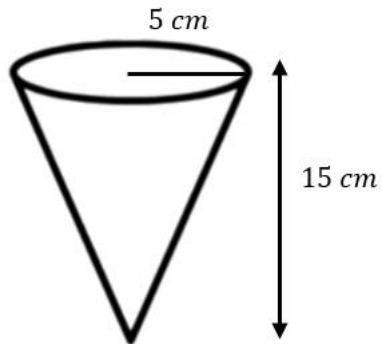

- 13) A cone and a pyramid have the same height of 9 cm. The cone has a radius of 6 cm. The pyramid has a square base of side length x cm. Given the volume of the two shapes are equal, work out the value of x . Give your answer to 1 decimal place.

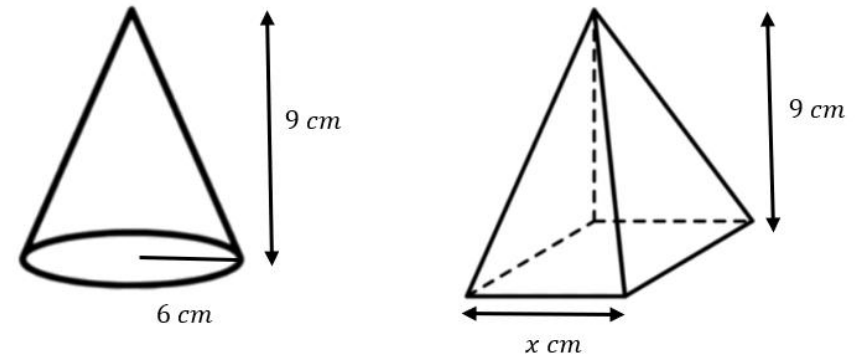

Challenge – Higher Tier Only

- 14) A solid toy is made by joining a hemisphere to a cylinder. The cylinder and the hemisphere both have a radius of r cm. The height of the cylinder is 10 cm.

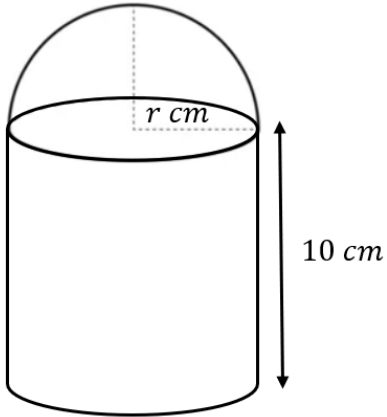

The total volume of the toy is V cm³.

Show that:

$$V = \frac{2\pi r^3 + 30\pi r^2}{3}$$

- 15) The radius of a sphere is increased by 2 cm.
The new sphere has twice the volume of the original sphere.
Show that $r^3 - 6r^2 - 12r - 8 = 0$.