

VOLUME OF PRISMS

1) Work out the volume of the cuboid.

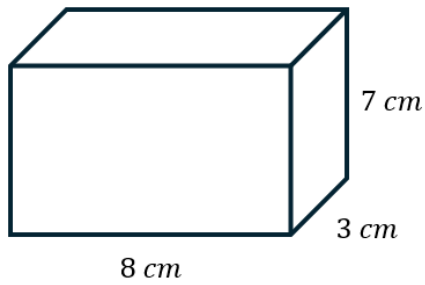

$$V = 8 \times 7 \times 3$$

$$= 168 \text{ cm}^3$$

2) Work out the volume of the cuboid.

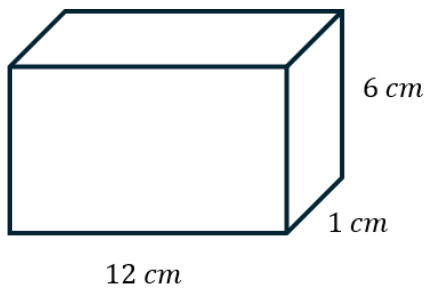

$$V = 12 \times 6 \times 1$$

$$= 72 \text{ cm}^3$$

3) A cube is shown below. Work out the volume of the cube.

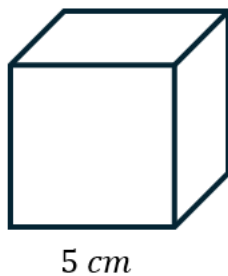

$$V = 5 \times 5 \times 5$$

$$= 125 \text{ cm}^3$$

- 4) Given that the volume of the cube is 216 cm^3 , work out the value of x .

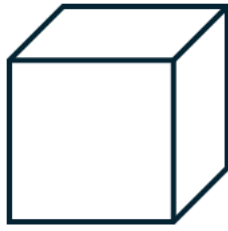

$x \text{ cm}$

$$x = \sqrt[3]{216} = 6$$

- 5) The volume of the cuboid shown below is 364 mm^3 . Work out the value of x .

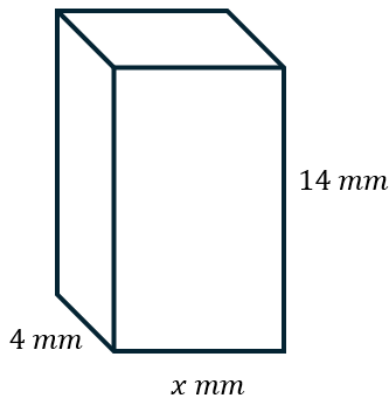

$$V = 14 \times 4 \times x$$

$$56x = 364$$

$$x = 6.5$$

- 6) Work out the volume of the triangular prism.

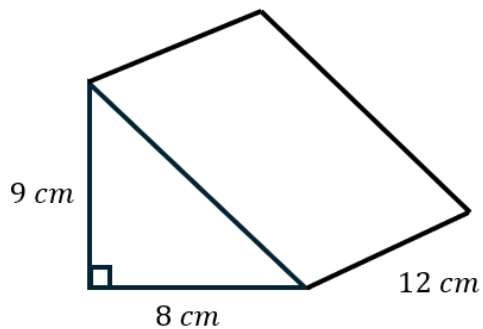

$$V = \left(\frac{9 \times 8}{2}\right) \times 12$$

$$= 36 \times 12$$

$$= 432 \text{ cm}^3$$

7) Work out the volume of the triangular prism.

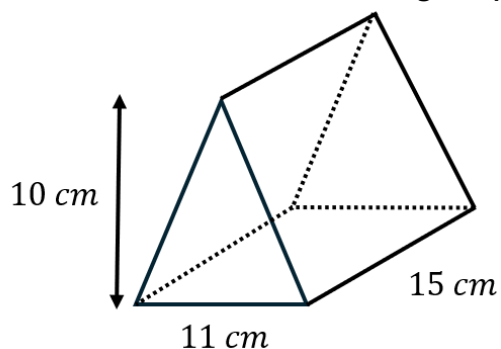

$$\begin{aligned}V &= \left(\frac{10 \times 11}{2}\right) \times 15 \\ &= 55 \times 15 \\ &= \mathbf{825 \text{ cm}^3}\end{aligned}$$

8) The cross section of the prism shown below is a trapezium. Work out the volume of the prism.

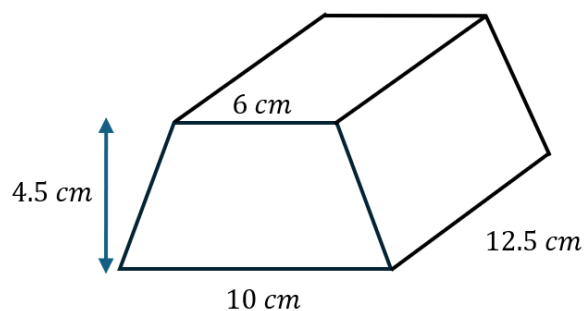

$$\begin{aligned}V &= \frac{1}{2} \times (a + b) \times h \times \text{length} \\ &= \frac{1}{2} \times (6 + 10) \times 4.5 \times 12.5 \\ &= \mathbf{450 \text{ cm}^3}\end{aligned}$$

9) A trapezium-prism is shown below. Given that the volume of the prism is 800 cm^3 , work out the value of h .

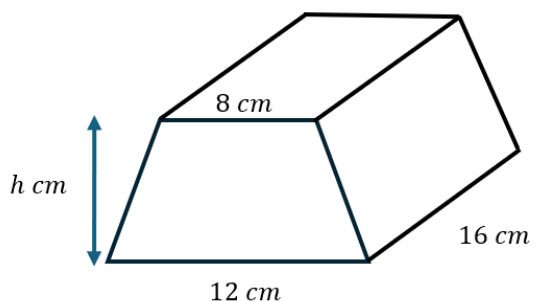

$$\begin{aligned}V &= \frac{1}{2} (a + b) \times h \times \text{length} \\ \frac{1}{2} \times (8 + 12) \times h \times 16 &= 800 \\ 160h &= 800 \\ \mathbf{h} &= \mathbf{5}\end{aligned}$$

- 10) The cylinder shown below has a radius of 4 cm and a height of 8 cm. Work out the volume of the cylinder. Give your answer to 1 decimal place.

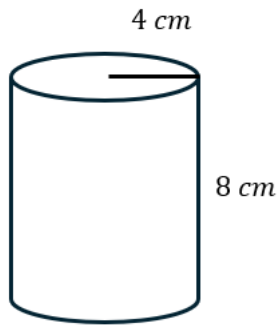

$$\begin{aligned}V &= \pi \times r^2 \times l \\&= \pi \times 4^2 \times 8 \\&= 402.1238 \dots \\&= \mathbf{402.1 \text{ cm}^3} \text{ (1 dp)}\end{aligned}$$

- 11) The cylinder shown below has a radius of 6.5 mm and a length of 14 mm. Work out the volume of the cylinder. Give your answer to the nearest unit.

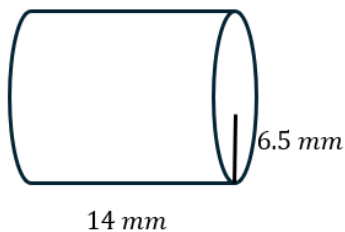

$$\begin{aligned}V &= \pi \times r^2 \times l \\&= \pi \times 6.5^2 \times 14 \\&= 1858.252 \dots \\&= \mathbf{1858 \text{ mm}^3} \text{ (unit)}\end{aligned}$$

- 12) The cylinder shown below has a diameter of 12 cm and a height of 16 cm. Work out the volume of the cylinder. Give your answer in terms of π .

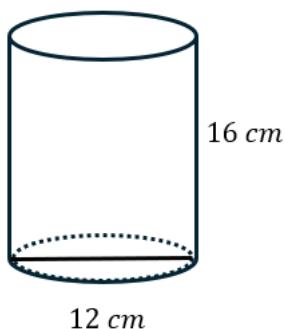

$$\begin{aligned}V &= \pi \times r^2 \times l \\&= \pi \times 6^2 \times 16 \\&= \mathbf{576\pi \text{ cm}^3}\end{aligned}$$

- 13) A company is designing a glass aquarium for a hotel lobby.
The aquarium is in the shape of a cuboid as shown below.

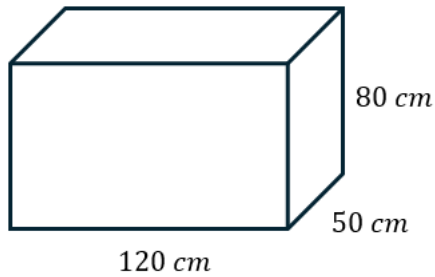

The tank will be filled completely with water. Work out the number of litres needed to fill the tank.

$$V = 120 \times 50 \times 80 = 480000 \text{ cm}^3$$

$$1 \text{ cm}^3 = 1 \text{ mL}$$

Number of litres needed:

$$480000 \div 1000 = 480 \text{ L}$$

- 14) A water treatment tank has an L-shaped cross-section. The dimensions are as shown below.

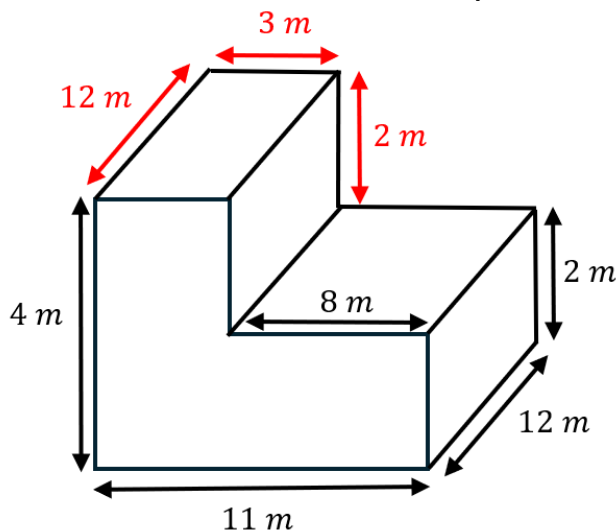

Unfortunately, the tank develops a leak.

The tank loses 36 m^3 of water in 4 hours.

Given the leak is not stopped for 7 hours and the water flows out at a constant rate, how much water is left in the tank when the leak is stopped?

Rate lost per hour:

$$36 \div 4 = 9 \text{ m}^3$$

After 7 hours:

$$9 \times 7 = 63 \text{ m}^3$$

Volume of water tank:

$$V = (4 \times 3 \times 12) + (8 \times 2 \times 12) = 336 \text{ m}^3$$

Water left:

$$336 - 63 = 273 \text{ m}^3$$

- 15) A farmer stores diesel in a large cylindrical tank.
The tank has a radius of 1.2 m and height of 3 m.

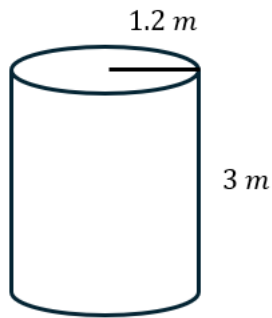

Diesel costs £1.45 per litre.

Calculate the total cost to fill the tank completely.

$$\begin{aligned}V &= \pi \times r^2 \times l \\ &= \pi \times 1.2^2 \times 3 \\ &= 4.32\pi \text{ m}^3\end{aligned}$$

$$1 \text{ m}^3 = 1000 \text{ litres}$$

Litres needed:

$$4.32\pi \times 1000 = 4320\pi$$

Cost:

$$\begin{aligned}4320\pi \times 1.45 \\ &= 19678.9363 \dots \\ &= \mathbf{\pounds 19678.94}\end{aligned}$$

Challenge

16) Given that the volume of the prism shown below is 408 cm^3 , work out the value of x .

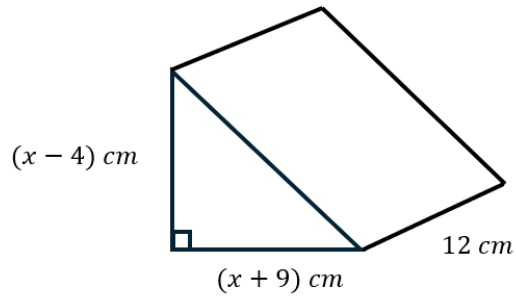

$$V = \frac{(x - 4)(x + 9)}{2} \times 12 = 408$$

$$6(x - 4)(x + 9) = 408$$

$$(x - 4)(x + 9) = 68$$

$$x^2 + 9x - 4x - 36 = 68$$

$$x^2 + 5x - 36 = 68$$

$$x^2 + 5x - 104 = 0$$

$$(x - 8)(x + 13) = 0$$

$$x = 8 \quad \text{or} \quad x = -13$$

$$x = 8$$

17) Given that the cylinder pictured below has a radius of $4x \text{ cm}$, a height of $(2y + 10) \text{ cm}$ and a volume of 56 cm^3 write an expression for y in terms of x and π .

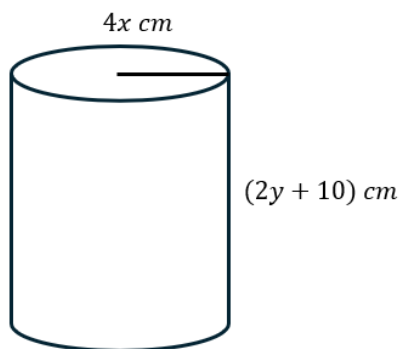

$$V = \pi \times r^2 \times l$$

$$\pi \times (4x)^2 \times (2y + 10) = 56$$

$$16\pi x^2(2y + 10) = 56$$

$$32\pi x^2 y + 160\pi x^2 = 56$$

$$32\pi x^2 y = 56 - 160\pi x^2$$

$$y = \frac{56 - 160\pi x^2}{32\pi x^2}$$