

VOLUME OF PRISMS

- 1) Work out the volume of the cuboid.

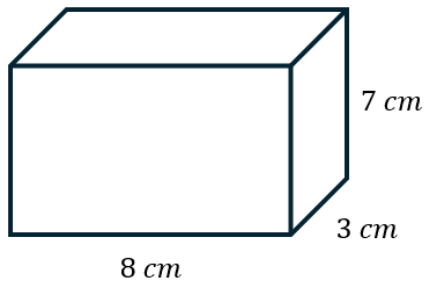

- 2) Work out the volume of the cuboid.

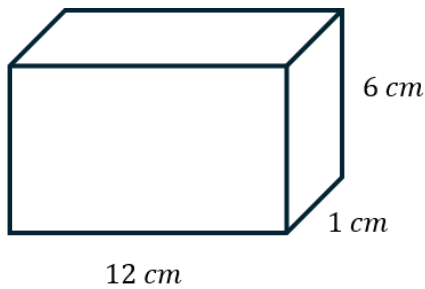

- 3) A cube is shown below. Work out the volume of the cube.

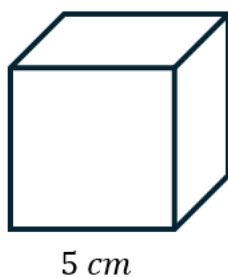

- 4) Given that the volume of the cube is 216 cm^3 , work out the value of x .

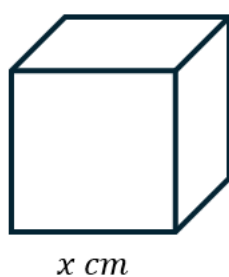

- 5) The volume of the cuboid shown below is 364 mm^3 . Work out the value of x .

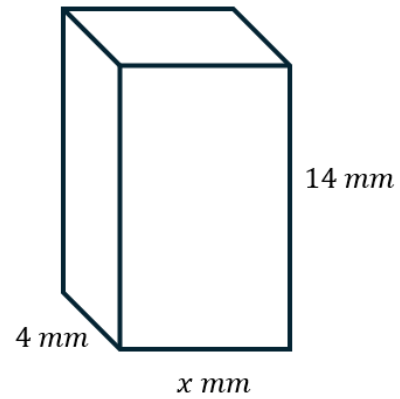

- 6) Work out the volume of the triangular prism.

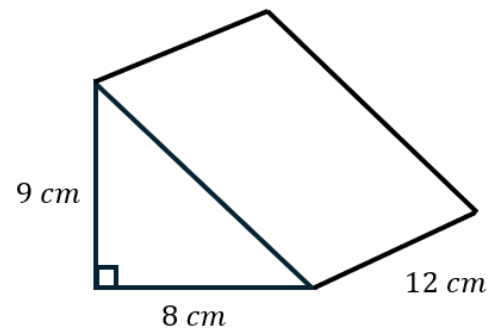

- 7) Work out the volume of the triangular prism.

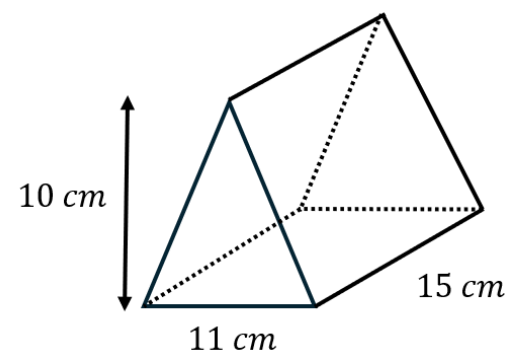

- 8) The cross section of the prism shown below is a trapezium. Work out the volume of the prism.

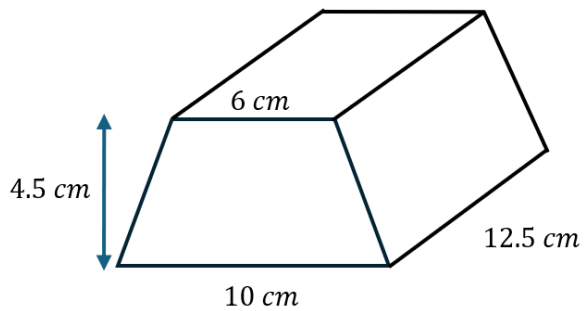

- 9) A trapezium-prism is shown below. Given that the volume of the prism is 800 cm^3 , work out the value of h .

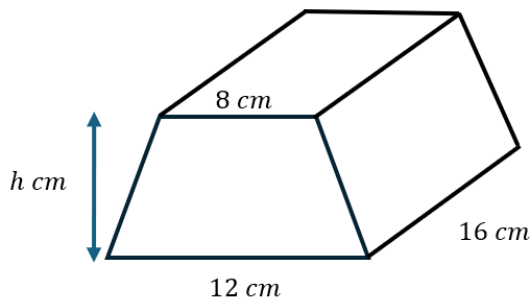

- 10) The cylinder shown below has a radius of 4 cm and a height of 8 cm. Work out the volume of the cylinder. Give your answer to 1 decimal place.

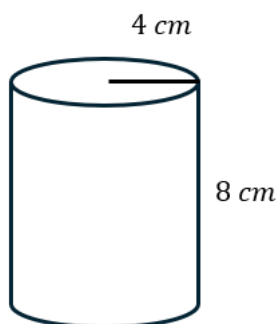

- 11) The cylinder shown below has a radius of 6.5 mm and a length of 14 mm. Work out the volume of the cylinder. Give your answer to the nearest unit.

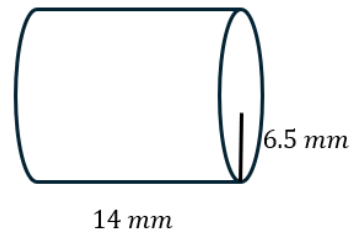

- 12) The cylinder shown below has a diameter of 12 cm and a height of 16 cm. Work out the volume of the cylinder. Give your answer in terms of π .

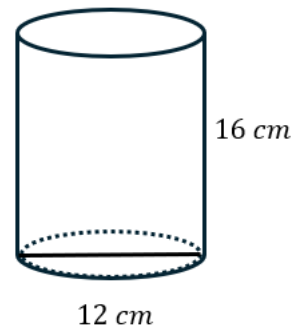

- 13) A company is designing a glass aquarium for a hotel lobby. The aquarium is in the shape of a cuboid as shown below.

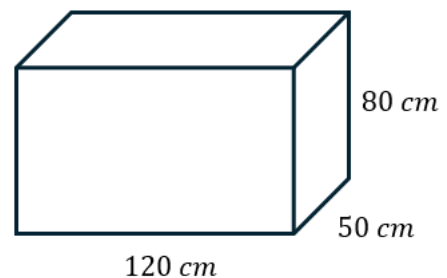

The tank will be filled completely with water. Work out the number of litres needed to fill the tank.

- 14) A water treatment tank has an L-shaped cross-section. The dimensions are as shown below.

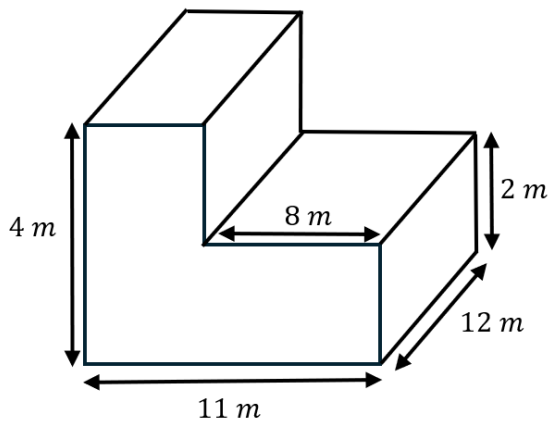

Unfortunately, the tank develops a leak.

The tank loses 36 m^3 of water in 4 hours.

Given the leak is not stopped for 7 hours and the water flows out at a constant rate, how much water is left in the tank when the leak is stopped?

- 15) A farmer stores diesel in a large cylindrical tank.

The tank has a radius of 1.2 m and height of 3 m.

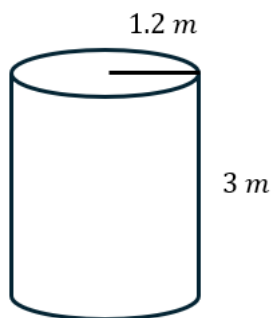

Diesel costs £1.45 per litre.

Calculate the total cost to fill the tank completely.

Challenge

- 16) Given that the volume of the prism shown below is 408 cm^3 , work out the value of x .

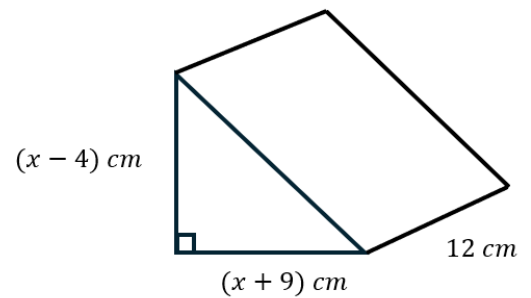

- 17) Given that the cylinder pictured below has a radius of $4x \text{ cm}$, a height of $(2y + 10) \text{ cm}$ and a volume of 56 cm^3 , write an expression for y in terms of x and π .

