



DCT28 Traceable Butterfly Valves are crucial components designed for controlling the flow of liquids and gases in a variety of industrial and commercial applications. These valves feature a robust, wafer-style body with a disc that pivots on a single axis, providing precise flow control. The wafer design facilitates easy installation between flanges and is ideal for applications where space is limited.

Scope of Application

- Water Treatment Plants
- HVAC Systems
- Process Industries
- Pumping Stations
- Mining and Metals
- Power Generation
- Wastewater Management
- Agricultural Irrigation
- Food and Beverage Industry
- Fire Protection Systems

Optional

- 300 PSI

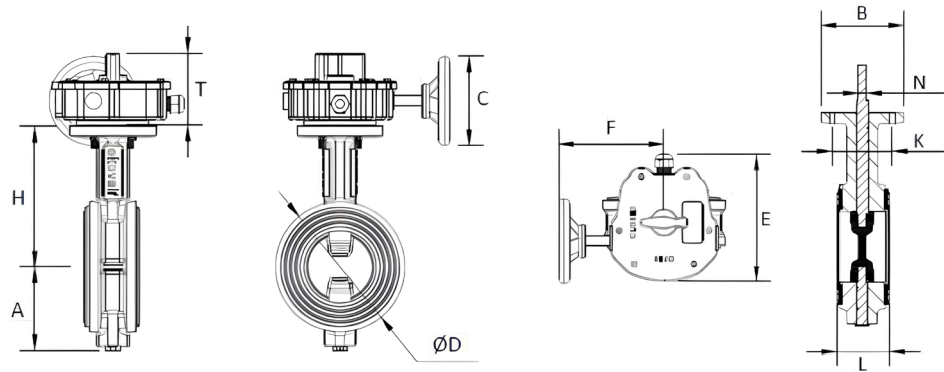

Material Specifications

NU	PART NAME	MATERIAL
	Body	EN GJS 500 - Ductile Iron
	Gasket	EPDM - NBR
	Flap	EN GJS 500 - Ductile Iron + EPDM Coated
	Standard	175 PSI



Dimensions

DN (mm)	A	B	C	D	E	F	H	WEIGHT
50	70	90	122	102	175	145	122	4,5
65	72	90	122	110	175	145	124	5
80	82	90	122	138	175	145	147	6
100	95	90	122	152	175	145	174	7,5
125	103	90	210	185	175	145	180	10,5
150	120	90	210	210	175	145	200	12
200	148	90	210	260	175	145	222	14