



The DCT27 Pre-Action Valve is engineered for advanced fire protection in pre-action sprinkler systems, providing reliable and timely water discharge when a fire is detected. Designed to enhance safety in sensitive and high-risk environments, this valve ensures precise control and effective response to fire emergencies.

Scope of Application

- Data Centers
- Museums and Archives
- Healthcare Facilities
- Commercial Buildings
- Telecommunication Facilities
- Libraries
- Manufacturing Facilities
- Electrical Equipment Rooms
- Airports and Transportation Hubs
- Chemical Processing Plants

Optional

- 300 PSI

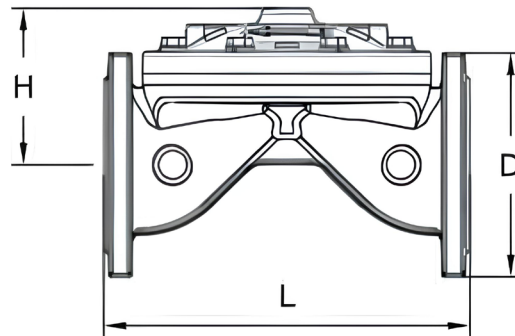

Material Specifications

NU	PART NAME	MATERIAL
	Body	EN GJS 500 - Ductile Iron
	Cover	EN GJS 500 - Ductile Iron
	Standard	230 PSI



Dimensions

DN (mm)	D	H	L	WEIGHT
50	165	105	225	16
65	185	110	250	19
80	200	125	305	24
100	220	145	330	30
125	250	227	380	48
150	285	244	400	51
200	340	272	450	79