



The DCT24 Wet Alarm Valve is specifically designed for reliable water flow monitoring and alarm activation in wet pipe fire protection systems. Engineered for dependable performance, this valve plays a critical role in detecting and responding to water flow within fire suppression systems, ensuring prompt and effective fire response.

### Scope of Application

- Industrial Facilities
- Commercial Buildings
- Municipal Infrastructure
- Healthcare Facilities
- Educational Institutions
- Residential Complexes
- Data Centers
- Transportation Hubs

### Optional

- 300 PSI

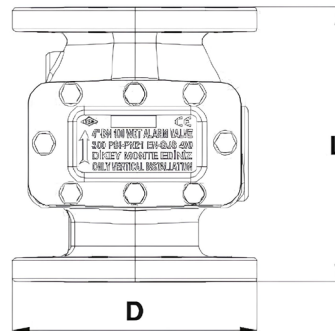
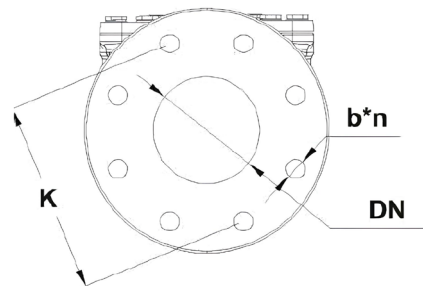

### Material Specifications

NU	PART NAME	MATERIAL
	Body	EN GJS 500 - Ductile Iron
	Cover	EN GJS 500 - Ductile Iron
	Standard	175 PSI



### Dimensions

DN (mm)	D	K	L	b*n	WEIGHT
100	220	180	345	19x8	38
150	285	240	480	23x8	77
200	340	295	560	23x12	138