

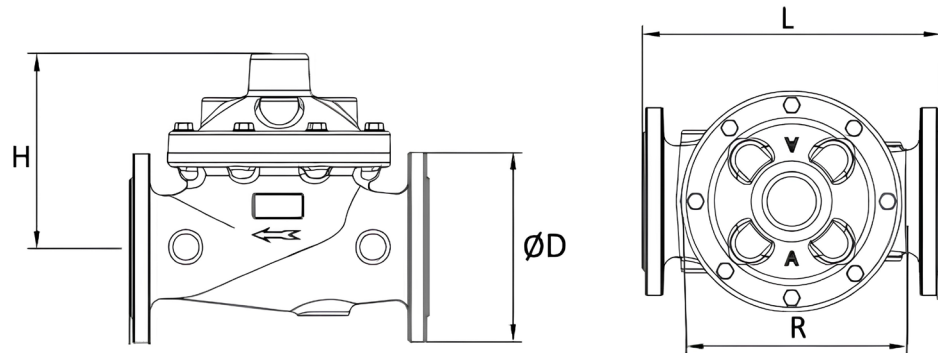

The DCT22 Pump Control Valve is specifically engineered for the regulation of fluid flow in pump systems, offering reliable performance and enhanced control. Designed to handle the demands of pump operations, this valve ensures efficient management of fluid dynamics across a range of applications.

Scope of Application

- Water Distribution Systems
- Industrial Processes
- Oil and Gas Industry
- HVAC Systems
- Fire Protection Systems
- Agriculture
- Pharmaceutical and Food & Beverage Industries
- Mining
- Energy and Utilities



Material Specifications

NU	PART NAME	MATERIAL
	Body	EN GJS 500 - Ductile Iron
	Cover	EN GJS 500 - Ductile Iron
	Standard	Globe Type



Dimensions

DN (mm)	D	H	L	R	WEIGHT
50	165	185	240	175	15
65	185	200	280	200	22
80	200	220	310	220	26
100	220	240	345	260	38
150	285	330	480	360	77
200	340	385	560	400	138