

The DCT19 Water Hammer Prevention Valve is a cutting-edge solution designed to protect fluid systems from the damaging effects of water hammer. Engineered for reliability and efficiency, this valve is ideal for industrial, commercial, and municipal applications where preventing pressure surges and maintaining system integrity are crucial.



Scope of Application

- Water Distribution Systems
- Industrial Processes
- Oil and Gas Industry
- HVAC Systems
- Fire Protection Systems
- Agriculture
- Pharmaceutical and Food & Beverage Industries
- Mining
- Energy and Utilities

Optional

- Globe Type

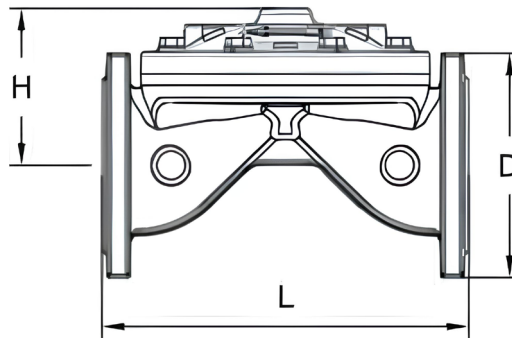

Material Specifications

NU	PART NAME	MATERIAL
	Body	EN GJS 500 - Ductile Iron
	Cover	EN GJS 500 - Ductile Iron
	Standard	Diaphragm Coated Straight Type

Dimensions

DN (mm)	D	H	L	WEIGHT
50	165	105	225	13
65	185	110	250	16
80	200	125	305	21
100	220	145	330	27
125	250	227	380	45
150	285	244	400	48
200	340	272	450	76