

The DCT15 Solenoid Control Valve is a high-performance component designed to provide precise control over fluid flow in various systems. Engineered for versatility and reliability, this valve is ideal for a broad range of industrial, commercial, and municipal applications, offering efficient and dependable fluid management.

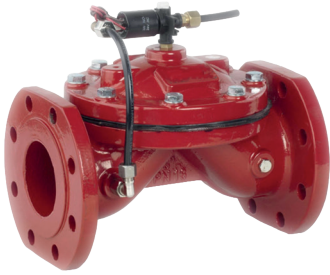

### Scope of Application

- Water Distribution Systems
- Industrial Processes
- Oil and Gas Industry
- HVAC Systems
- Fire Protection Systems
- Agriculture
- Pharmaceutical and Food & Beverage Industries
- Mining
- Energy and Utilities

### Optional

- Globe Type

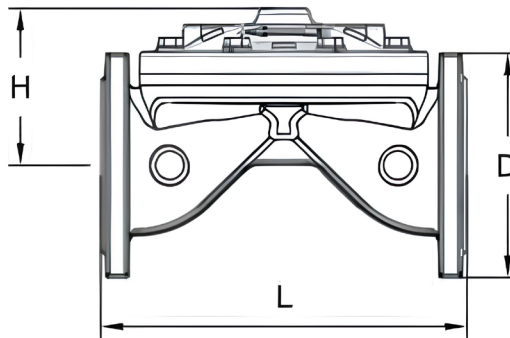

### Material Specifications

NU	PART NAME	MATERIAL
	Body	EN GJS 500 - Ductile Iron
	Cover	EN GJS 500 - Ductile Iron
	Standard	Diaphragm Coated Straight Type



### Dimensions

DN (mm)	D	H	L	WEIGHT
50	165	105	225	13
65	185	110	250	16
80	200	125	305	21
100	220	145	330	27
125	250	227	380	45
150	285	244	400	48
200	340	272	450	76