



The DCT12 Pressure Relief Control Valve is a high-performance component designed to protect fluid systems from overpressure by releasing excess pressure and maintaining safe operational levels. Ideal for use in various industrial, municipal, and commercial applications, this valve ensures system safety and reliability through precise pressure management.

### Scope of Application

- Water Distribution Systems
- Industrial Processes
- Oil and Gas Industry
- HVAC Systems
- Fire Protection Systems
- Agriculture
- Pharmaceutical and Food & Beverage Industries
- Mining
- Energy and Utilities

### Optional

- Globe Type

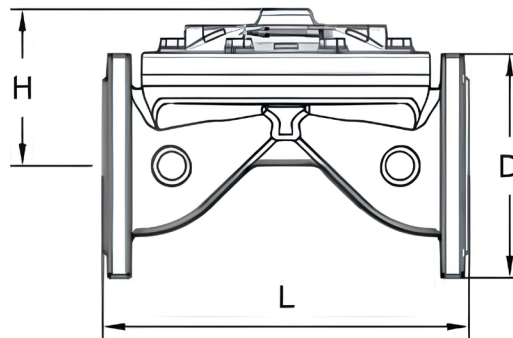

### Material Specifications

NU	PART NAME	MATERIAL
	Body	EN GJS 500 - Ductile Iron
	Cover	EN GJS 500 - Ductile Iron
	Standard	Diaphragm Coated Straight Type

### Dimensions

DN (mm)	D	H	L	WEIGHT
50	165	105	225	13
65	185	110	250	16
80	200	125	305	21
100	220	145	330	27
125	250	227	380	45
150	285	244	400	48
200	340	272	450	76