



The DCT10 Pressure Reducing Control Valve (PRCV) is a sophisticated component engineered to manage and stabilize pressure levels in fluid systems, ensuring optimal performance and safety across a range of industrial and commercial applications. Designed for precision and reliability, this valve plays a critical role in controlling pressure variations and maintaining system integrity.

Scope of Application

- Water Distribution Systems
- Industrial Processes
- Oil and Gas Industry
- HVAC Systems
- Fire Protection Systems
- Agriculture
- Pharmaceutical and Food & Beverage Industries
- Mining
- Energy and Utilities

Optional

- Globe Type

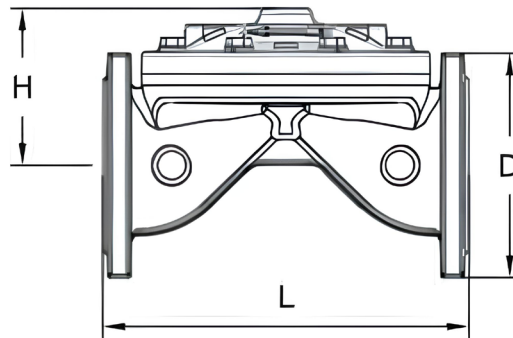

Material Specifications

NU	PART NAME	MATERIAL
	Body	EN GJS 500 - Ductile Iron
	Cover	EN GJS 500 - Ductile Iron
	Standard	Diaphragm Coated Straight Type

Dimensions

DN (mm)	D	H	L	WEIGHT
50	165	105	225	13
65	185	110	250	16
80	200	125	305	21
100	220	145	330	27
125	250	227	380	45
150	285	244	400	48
200	340	272	450	76