

SmartBlock^{FM}

Design and Product Manual

October 2003 Edition

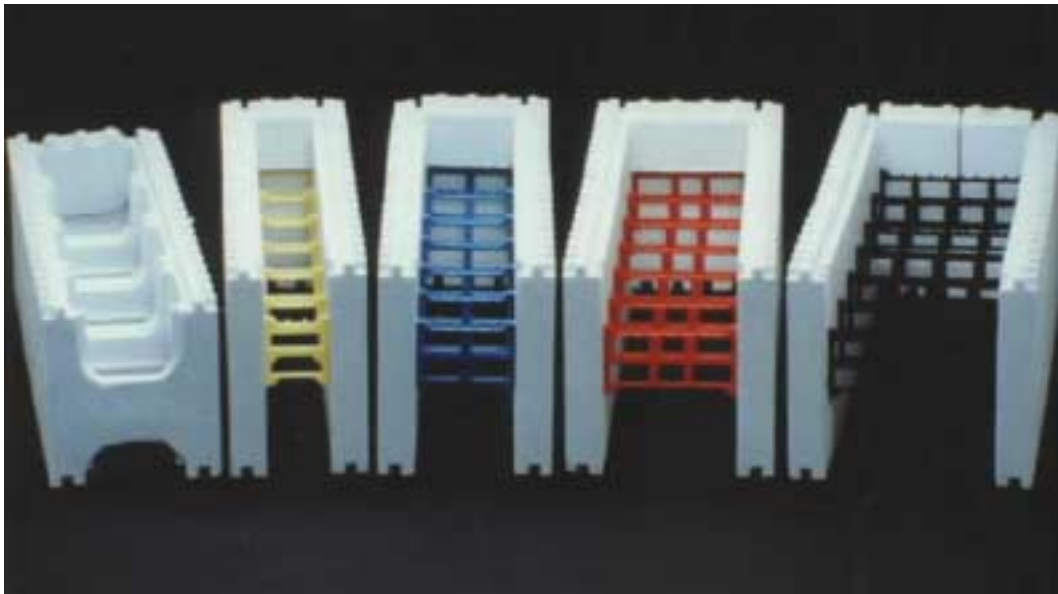

1-800-CONFORM
www.smartblock.com

This manual contains proprietary information that is the property of American ConForm Industries, Inc.
© 1989 - 2003 American ConForm® Industries, Inc.

SmartBlock™ Design and Product Manual

October 2003 Edition

TABLE OF CONTENTS

<u>EXHIBIT</u>		<u>PAGE</u>
Chapter 1	INTRODUCTION	
1.1	Introduction	5
1.2	What is EPS?	7
Chapter 2	SITE WORK AND FOUNDATIONS	
2.1	Site Work - Monolithic Pours	8
2.2	Forming Fabrication	8
2.3	Foundation Systems	9
2.3.1	Slab on Grade	8
2.3.2	Stem Wall Foundation	10
Chapter 3	BUILDING WALLS	
3.1	Footings	11
3.2	Reinforcing Steel	12
3.3	Ledgers	12
3.4	Lintels	13
3.5	Plates	13
3.6	Lateral Design	13
3.7	Structural Design	14
3.7.1	SF10 Series	14
3.7.1A	Flexural Design Capacity	14
3.7.1B	Allowable Lateral Loads	15
3.7.1C	Allowable Axial Loads	15
3.7.2	VWF Series	16
3.8	Bracing Techniques	17

Chapter 4	INTERIOR FINISHES	
4.1	Gypsum Wall Board	26
4.1.1	Horizontal Metal Strips	26
4.1.2	The SmartTach Anchor System	27
4.1.3	The SmartTach Installation Details	28
4.1.4	Other Attachment Methods	29
Chapter 5	DOORS & WINDOWS	
5.1	Frames	30
5.2	Reinforcing Steel	31
Chapter 6	EXTERIOR FINISH MATERIALS	
6.1	Below Grade Waterproofing	32
6.1.1	Liquid Emulsified Products	33
6.1.2	Sheet Goods	34
6.1.3	Acrylic Based Cements	34
6.1.4	Compatible Waterproofing Product List	35
6.2	Above Grade Exterior Finishes	37
6.2.1	Exterior Insulation Finish Systems	38
6.2.2	One Coat Stucco	38
6.2.3	Polymer Based Stuccos	39
6.2.4	Compatible Exterior Stucco List	40
6.3	Compatible Adhesive List	42
Chapter 7	PLUMBING AND ELECTRICAL	
7.1	Introduction to Plumbing and Electrical	43
7.2	Plumbing	43
7.2.1	Direct Embedment	43
7.2.2	Protection of Pipes	44
7.2.3	Installation Recommendations	44
7.2.4	Support of Pipes	46
7.3	Electrical	46
Chapter 8	MANUFACTURERS SPECIFICATIONS	
8.1	Manufacturers Technical Specifications	48
8.2	Energy Analysis	50

8.2.1	SF10 Series	50
8.2.2	VWF Series	50
8.3	Sound Transmission	52
8.4	Concrete Specifications	53
8.5	Concrete Estimation	54
8.6	Block Estimation	55
8.7	Tools and Materials	56
8.8	Radius Cut Outs	57

Chapter 9 DESIGN DETAILS

9.1	Design Section	60
	Table A - Retaining Wall Chart (3'-6')	61
	Table B - Retaining Wall Chart (8')	66
	Table C - Retaining Wall Chart (10')	67
	Table D - Stem Wall Foundations - Wood Frame Walls	68
	Table E - Full Height SmartBlock Walls	68
9.2	Detail Section	69
	1.0 - Controlled Ventilated Crawl Space Detail	70
	2.0 - Retaining Wall Detail	71
	3.0 - Retaining Wall Detail	72
	4.0 - Retaining Wall Detail	73
	5.0 - Foundation Detail	74
	6.0 - Foundation Detail	75
	7.0 - Foundation Detail, Joist Running Parallel	76
	8.0 - Foundation Detail, Joist Running Perpendicular	77
9.0	Foundation Detail, Interior Bearing Foundation, Joist Running Perpendicular	78
10.0	- Foundation Detail, Interior Bearing Foundation, Joist Running Parallel	79
	11.0 - Full Height Wall Section, Two Story	80
	12.0 - Ledger Detail, Flush Mounted	81
	13.0 - Ledger Detail, Flush Mounted	82
	14.0 - Lintel Detail at Eave	83
	15.0 - Eave Detail, Rafter Running Parallel	84
	16.0 - Eave Detail, Rafter Running Perpendicular	85

17.0 - Gyp. Board Attachment Detail, Horiz. Metal Strip Method	86
18.0 - Window Detail, Head	87
19.0 - Chase Detail, 3” Vertical Drop at Ledger	88
19.0A - Section “A-A” Plumbing Chase Detail	89
20.0 - Electrical Placement	90
21.0 - Electrical Placement—Alternative View	91
22.0 - Corner Construction	92
23.0 - 4” Brick Veneer for 2x4 Stud Wall	93
9.3 Miscellaneous Details	94
Chapter 10 SUPPORT REPORTS	
10.1 ICBO ES Evaluation Report No. 4572	110
10.2 BOCA Research Report No. 95-46	121
10.3 Wisconsin DILHR Material Approval No. 920083-I	128
10.4 Los Angeles Research Report No. 25006	132
10.5 Texas Department of Insurance – Product Evaluation FR-24	136
10.6 Structural Design Calculations for SF10 Series	139
10.7 CSI Technical Specifications	146

CHAPTER 1

Introduction



SmartBlock, Fast, Easy, Energy Efficient.



Since 1988, patented, SmartBlock concrete forms are the best.

Chapter 1 INTRODUCTION

1.1 Introduction

This manual introduces builders, contractors, architects and engineers to the design parameters and potential applications of SmartBlock™ insulating forms.

SmartBlock insulating forms are expanded polystyrene (EPS) forms for pouring concrete load-bearing, shear and foundation walls. The forms are left in place after concrete is poured and provide superior insulation relative to conventional wood, concrete and masonry walls.

The units are manufactured in two basic types, Standard Forms (SF10 Series) and Variable Width Forms (VWF Series). Both forms have rows of interlocking teeth at the top and bottom to facilitate easy assembly. The form units remain after placing of reinforcing steel and concrete and must be protected by approved interior and exterior finish materials.

The SF10 Series units are 10 inches high by 10 inches wide by 40 inches long. The face shell thickness of the SF10 Series is $1\frac{3}{4}$ inches. When assembled, the units form $7\frac{1}{2}$ inch by $6\frac{1}{2}$ inch rectangular vertical cores at 10 inches on center and $6\frac{1}{2}$ inch by $6\frac{1}{4}$ inch rectangular horizontal cores at 10 inches on center.

The VWF Series units are 12 inches high by 40 inches long and can be assembled in varying widths providing concrete walls of $3\frac{3}{4}$ inches, $5\frac{3}{4}$ inches, $7\frac{3}{4}$ inches, $9\frac{3}{4}$ inches, $11\frac{3}{4}$ and other custom made widths. The average face shell thickness of the VWF Series is 2.125". The facing walls of the form are interconnected with eight plastic bridge inserts.

SmartBlock insulating forms are molded from EPS beads manufactured by BASF Corporation (ICBO Evaluation Report No. 3401) or Huntsman Chemical Corporation (NER-348), having a density of 1.5 to 2.0 pounds per cubic foot with a maximum flame-spread rating and smoke-

density of 10# and 250# respectively, in accordance with the 1991 Uniform Building Code (UBC) Standard No. 42-1.

SmartBlock insulating forms are recognized by ICBO ES (Evaluation Report No. 4572), BOCA ES (Research Report No. 95-46), State of New York DHCR (Certificate No. 624-93-MC), State of Wisconsin DILHR (Approval No. 980020-I), the City of Los Angeles (Research Report No. 25006) and various city and local building reports.

All users of SmartBlock insulating forms should refer to the enclosed copies of evaluation reports and reports released after publication of this manual. These reports contain revised conditions related to the use of SmartBlock insulating forms and should be kept current by all users of the product. The manufacturer on request will provide updates, but use of SmartBlock insulating forms must be coordinated with local building officials.

The design concepts within this manual use industry standards for most typical applications. Trade and material associations have been consulted to verify the workability of the product and to ensure that these assemblies address general field conditions. Since specifics vary depending on local conditions, it is imperative that the individual project architect or engineer review all details, specifications and calculations. Structural designs and calculations are based upon normal allowable forces and loads, and tables are included to show a variety of applications for SmartBlock insulating forms. Due to varying load conditions and building codes, each project should be reviewed and approved by the project architect or engineer.

1.2 What Is Expanded Polystyrene (EPS)?

The use of EPS as formwork for concrete has a history in Europe dating back to 1950s. The use of EPS as formwork evolved from its use as an insulating material in construction.

There are two common types of polystyrene foam, extruded polystyrene (popularly known by its Dow trademark Styrofoam) and expanded polystyrene or EPS. Most food service applications including meat trays, egg cartons, hamburger clam shells, foam plates and trays are extruded polystyrene, as are most types of loose-fill packaging. However, the common coffee cup is made of EPS. Almost all industrial cushion packaging - the cellular white molded foam that is used to package televisions, stereos, computers and delicate electronic equipment, as well as other fragile industrial and consumer products - is also of EPS, as are most bicycle helmets. Both EPS and extruded polystyrene are used extensively as thermal insulation in industrial, commercial and residential construction.

As a raw material, EPS is produced in the form of white granules ranging in size from 8/1000ths to 12/1000ths of an inch. These granules, commonly referred to as bead or resin, feel something like very fine, polished sand. Three processing stages - prefoaming, intermediate storage and final foaming - turn the bead into rigid foamed plastic shapes, which in this case are SmartBlock insulating form units.

Unlike extruded polystyrene, EPS contains no chlorofluorocarbons (CFC's). EPS is inert and is less toxic than wood when burned. The EPS used in SmartBlock insulating forms contains fire resistant additives, which do not allow it to sustain a flame.

CHAPTER 2

Side Work and Foundations



Level footers start with a chalk line and cleat.



Interior cuts create curves and insulated slabs.

Chapter 2 SITE WORK AND FOUNDATIONS

2.1 Site Work - Monolithic Pours

Monolithic pour sites are prepared for construction of SmartBlock form walls in the same manner as for other common foundation forming systems. Set batter boards beyond all corners and stretch string lines across the location of the exterior faces of the walls. This procedure will locate the position of the corners. Using a plumb bob, set flag nails directly below the string at a distance of 4 to 6 feet apart, 1-foot from each corner. After completing the perimeter of the building, set a stake at each flag nail. Once the exterior stakes are in place, add an additional nail 1½” to the outside of the string location on the batter boards to offset the string. This will move the string out of the way for the next step and provide a wall alignment guide. Using stake material, build a spreader in an “L” shape: the bottom leg of the “L” should be 9¼” in length. Using the spreader, line up with the existing stake facing towards the interior of the building, setting interior rows of stakes directly opposite of exterior stakes. This setting of interior stakes will produce a ¾” toe-in that will hold SmartBlock insulating forms steady during pouring.

2.2 Forming Fabrication

Once the stakes are set, bottom horizontal rebar may be set as needed to satisfy foundation construction requirements. Calculate the required form height by subtracting the sub floor and sill depths and mark elevation on stakes. Two courses of SmartBlock insulating forms can be assembled and slid between stakes to a point of minimum depth of spread footing and held in place by the toe-in of the stakes. Subsequent rows of forms can be added setting vertical and horizontal rebar as required. Once forms are in place to the required elevation, as marked on the stakes, and all rebar is in place, stakes should be held together at the top using SmartBlock box clips. The foundation should now be ready for inspection and may be poured upon approval. While pouring, use a 2” x 4” with the 1½” string offset to check wall for alignment.

At the contractor's discretion, foundation hardware may be pre-clipped in place or set in concrete at pour. Pressure treated Douglas fir (PTDF) or foundation grade redwood sills should be placed and set while concrete is still wet.

Note: The forms may also be set on pre-poured footings to form a foundation and/or above grade wall, much in the same manner as in conventional concrete block construction.

2.3 Foundation Systems

This section addresses various foundation systems and analyzes design criteria for use of SmartBlock insulating forms with these systems.

2.3.1 Slab on Grade

Slab on grade construction with SmartBlock insulating forms (see Details 5.0 - 10.0 from Chapter 16) is similar to construction of stem wall footings in conjunction with slab construction. Trenches are excavated and SmartBlock insulating forms are installed as described in Chapter 2.1. Design and construction of the wall is similar to design with masonry block. Build the SmartBlock insulating form wall following the recommendations in Chapter 3 with reinforcing steel placed in accordance with project requirements. The slab should be standard thickness with adequate base material as required by the soils engineer, with the vapor barrier extending the full length under the slab to prevent moisture penetration.

2.3.2 *Stem Wall Foundation*

The use of SmartBlock insulating forms in stem wall foundations will reduce cost and improve energy efficiency especially when used for a controlled ventilated crawl space (CVC) or a perimeter insulated raised floor (PIRF) foundation system. See Detail 1.0 in Detail Section of Chapter 9.

The relation between the size and location of all openings in stem wall foundations must be considered by the designer in relation to required lintel frames and other supporting elements. Crawl space openings must be framed as detailed for window openings, and reinforcement must be placed as shown in those details, considering any concentrated or point loads occurring in that locale. If vent openings are located in the wall, the same care should be taken for vertical loading as with larger openings. In all cases approved treated lumber such as PTDF or foundation grade redwood should be used in direct contact with concrete.

When joists are running parallel to the foundation (Detail 7.0), use double joists nailed in accordance with the project documents. Inspect exterior joists for extreme size fluctuation (oversize) and warping to prevent accidental loading of this member. To insure proper wood coverage and workability of anchor bolts, it is recommended that a 2" x 6" minimum PTDF or foundation grade redwood sill be used.

In situations where incidental retaining capacities are required of a stem wall footing, SmartBlock insulating form walls will perform as any other common concrete wall system. In these situations wall design should incorporate all conditions customarily considered in retaining wall design. The building walls (Chapter 3) and design detail (Chapter 16) chapters of this manual contain tables and design criteria, respectively, that will assist the design professional in determining retaining capacities meeting with local code and soil conditions.

CHAPTER 3

Building Walls



Have bucks and stub outs ready.



Like masonry, start from the corner and stack toward the middle.

Chapter 3: BUILDING WALLS

This chapter addresses design aspects of the use of SmartBlock insulating forms in the construction of a building wall.

SmartBlock SF10 insulating forms can be used in exterior or interior bearing or non-bearing walls to an unsupported height of 10 ft. for 2 story construction in accordance with Finding #2 of ICBO ES Evaluation Report No. 4572. Higher building walls can be constructed with the SmartBlock VWF Series forms or with the SF10 Series by specific design by an architect or engineer.

This manual contains details and tables for use of SmartBlock SF10 Series insulating forms in building wall construction in accordance with ICBO ES Evaluation Report No. 4572, and BOCA Research Report No. 95-46.

3.1 Footings

Building walls constructed with SmartBlock insulating forms require an increase in spread footings sizes compared with conventional wood frame construction, due to the increased weight of concrete walls. This increased size acts to and compensate for shear at the wall plane at the footing. In tables A, B, C, D and E in Design Section of Chapter 9, soil bearing pressures are assumed to be 1000 psf. Individual soils analysis may reduce or increase these sizes.

3.2 Reinforcing Steel

Suggested reinforcing steel requirements, sizes and spacings are identified throughout in this manual. Reinforcement parameters should be in accordance with specific project design requirements.

3.3 Ledgers

In typical reinforced concrete or masonry construction, floors are supported by the use of a ledger (see Details 6.0, 12.0 and 13.0). Before the pour, to avoid cantilevering the anchor bolts used in the ledger, the SmartBlock insulating forms should be cut to allow proper surrounding of "J" bolts with concrete. Due to the thickness of the concrete cell, embedment requirements should be addressed in all ledgers and ledger bolt designs. Horizontal diaphragm shear may be transferred to the wall at this point and should be designed for each project.

To facilitate placement of reinforcing steel, all door and window openings should be constructed as fabrication proceeds rather than waiting until forming is complete. UBC requires that two No. 5 rebars are placed vertically and horizontally at each opening and the ends of the bars should extend a minimum of 24" beyond the corners of the opening. In the case of the restricted area past the corner of an opening, the bar may be bent to tie to the nearest horizontal or vertical reinforcing bar.

3.4 Lintels

Lintels over openings may be constructed as shown in Detail No. 14.0. The distance between the top and bottom reinforcing steel governs the strength of the lintel so rebar placement is critical. If foam bridging in the SF10 Series restricts placement of rebar around lintels, VWF Series may be substituted. All lintel applications must be reviewed and approved by the project architect or engineer.

3.5 Plates

The top plate may be installed in the same manner as common with other construction methods. The plate should consist of PTDF, foundation grade redwood or an approved equal. Due to shear forces at this level, anchor bolt spacings are designed depending on the size of plate used. Refer to table No. 25-F in the UBC for specific design parameters. Applications must be reviewed for compliance with local codes and conditions.

3.6 Lateral Design

Lateral design is addressed in various details showing typical nailing, clips, anchor bolts, etc. used in the field for shear transfer (see Chapter 16 - Details 6.0, 7.0, 8.0, 9.0, 10.0, 12.0, 13.0, 15.0 and 16.0). These details show possible solutions that must be designed in connection with lateral design. Each project must be analyzed individually since specific building design and local codes govern parameters of lateral design.

3.7 Structural Design

Unlike masonry walls that derive some structural value from concrete masonry units (CMU's), the SmartBlock insulating form contributes no structural value to the wall system. The structural strength of SmartBlock insulating form walls is provided solely by the reinforced concrete structure contained within the SmartBlock insulating forms.

3.7.1 SF10 Series

Section 10.6 of this manual contains a table of the allowable (factored) bending moments, lateral loads and axial loads of a concrete wall formed with SF10 Series insulating forms along with the supporting calculations for use by the design engineer and building officials.

The structural design capacities of the 6½ inch wide concrete wall contained within the SF10 Series insulating forms are in accordance with Chapter 19 of the 1997 UBC. However, the structural capacity of the SF10 Series wall is slightly reduced (compared to a solid 6½ inch wide concrete wall) because of the displacement of concrete by the 2½ inch by 3½ inch EPS bridges spaced on a 10 inch by 10 inch grid pattern.

3.7.1A Flexural Design Capacity

Since the 2½ inch wide EPS bridges in the SF10 Series block are spaced 10 inches apart horizontally, the effective width or “b” dimension of a SmartBlock insulating form wall is reduced 25% as compared to a solid concrete wall. Therefore, the “b” dimension per lineal foot of wall in the following equation:

$$a = A_s f_y / .85 f_c b$$

is 9 inches in lieu of the standard 12 inch dimension customary for wall design. Once the modified “b” dimension is calculated, calculation of the allowable moment is identical to a solid concrete wall design using the following equation:

$$fM = fA_s f_y (d - a/2)$$

3.7.1B Allowable Lateral Loads

Similar to flexural design, the “b” dimension in the following equation:

$$fV = f_2 \phi f_c (b)d$$

is 9 inches in lieu of the customary 12 inches for solid wall design.

3.7.1C Allowable Axial Loads

For the 6½ inch wide wall, the presence of the EPS bridges effects the axial load capacity of the wall by reducing A_g in the following equation:

$$fP = .55 f_c A_g [1 - (K_1/32h)^2]$$

A_g for the SF10 Series wall is 58.5 square inches (6.5 inches x 9 inches) in lieu of 78 square inches (6.5 inches x 12 inches) for a solid 6½ inch wall.

3.7.2 *VWF Series*

The VWF Series blocks are connected by plastic ties similar in size to ties used for conventionally formed concrete. Therefore, the structural capacities of walls using the VWF Series blocks are the same as for other concrete forming methods. These capacities may be calculated in accordance with Chapter 19 of the 1997 UBC for concrete wall widths of 3 $\frac{3}{4}$ inches, 5 $\frac{3}{4}$ inches, 7 $\frac{3}{4}$ inches, 9 $\frac{3}{4}$ inches and 11 $\frac{3}{4}$ inches.

Smart Block

BRACING TECHNIQUES

NOTE: The drawing represent possible methods of supplying alignment support for your Smart Block wall. They are intended to be use as guided only, and are not to scale. Proper support will vary depending upon site condition, concrete pressures, wall height, soil capacities and the overall building system being incorporated or architect for precise bracing requirements.

AT ALL CORNERS, CUT THE
SIDE OF THE BLOCK TO CREATE
A CONTINUOUS HORIZONTAL
CELL OF CONCRETE

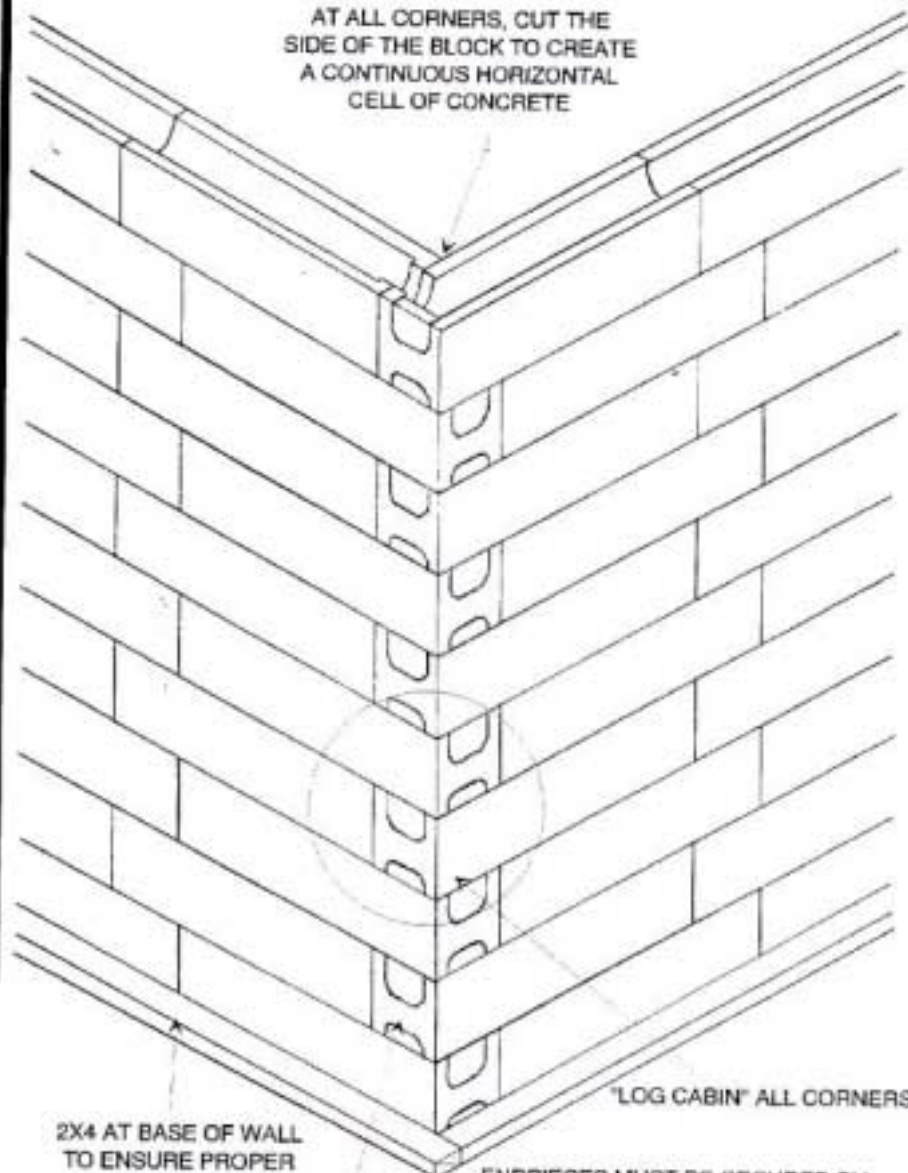

2X4 AT BASE OF WALL
TO ENSURE PROPER
ALIGNMENT

SF 10 WITH END
PIECE

"LOG CABIN" ALL CORNERS

ENDPIECES MUST BE SECURED BY
TAPE, BRACING, OR OTHER MEANS
TO ENSURE STRUCTURAL CONTINUITY
OF THE FORMWORK

CORNER CONSTRUCTION

SF SERIES

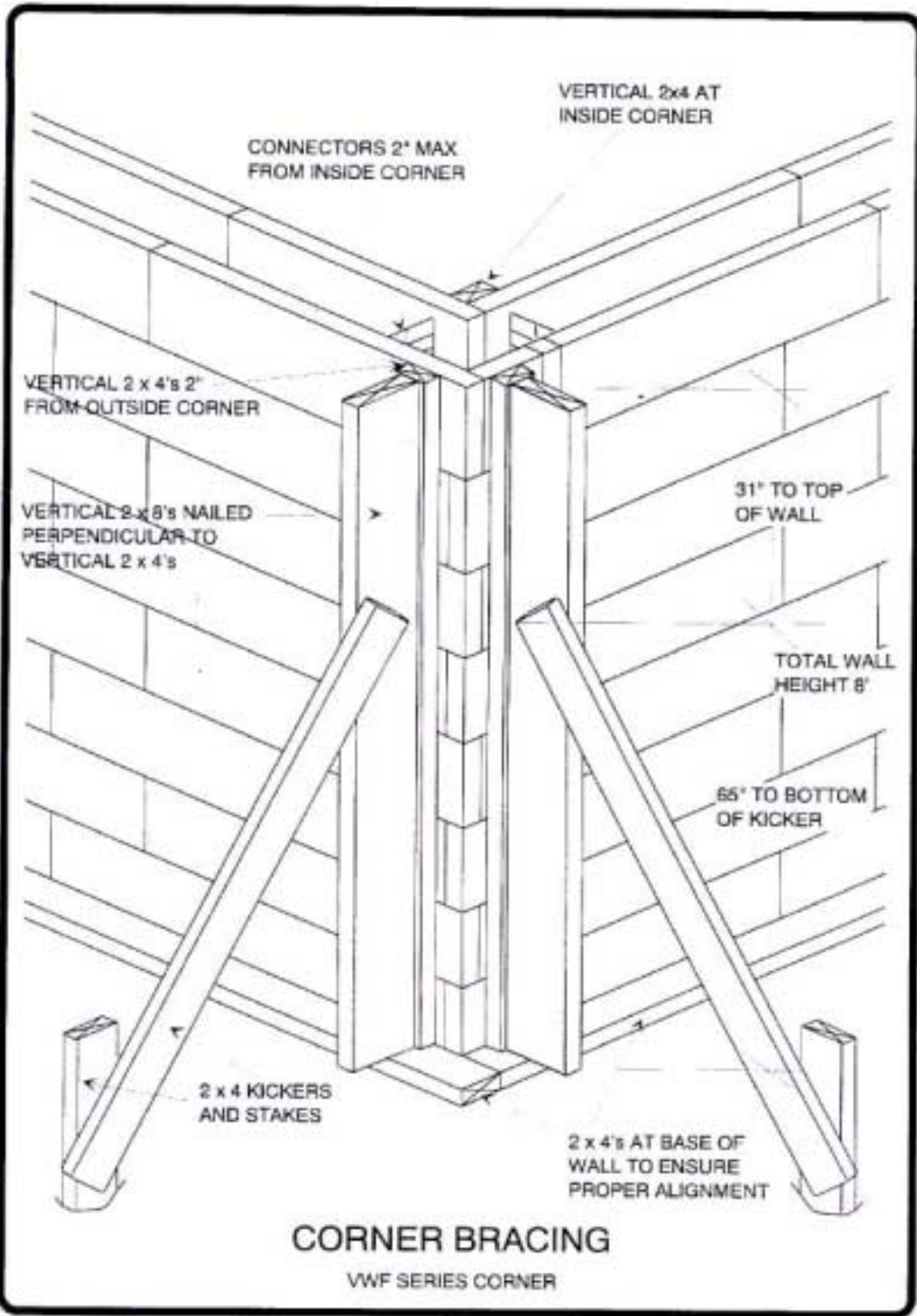

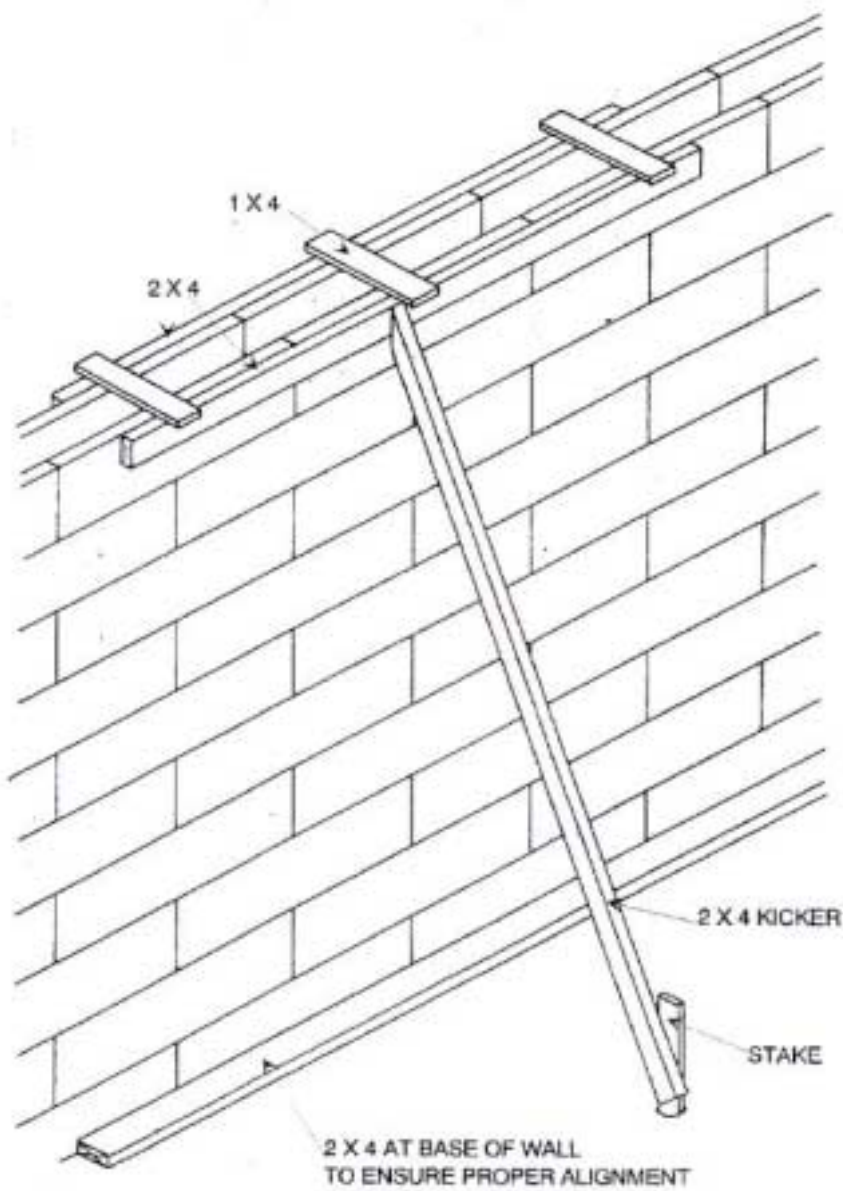

LADDER BRACE

ALL SERIES

INSTALL LADDER BRACE AT TOP
OF WALL TO ENSURE ALIGNMENT

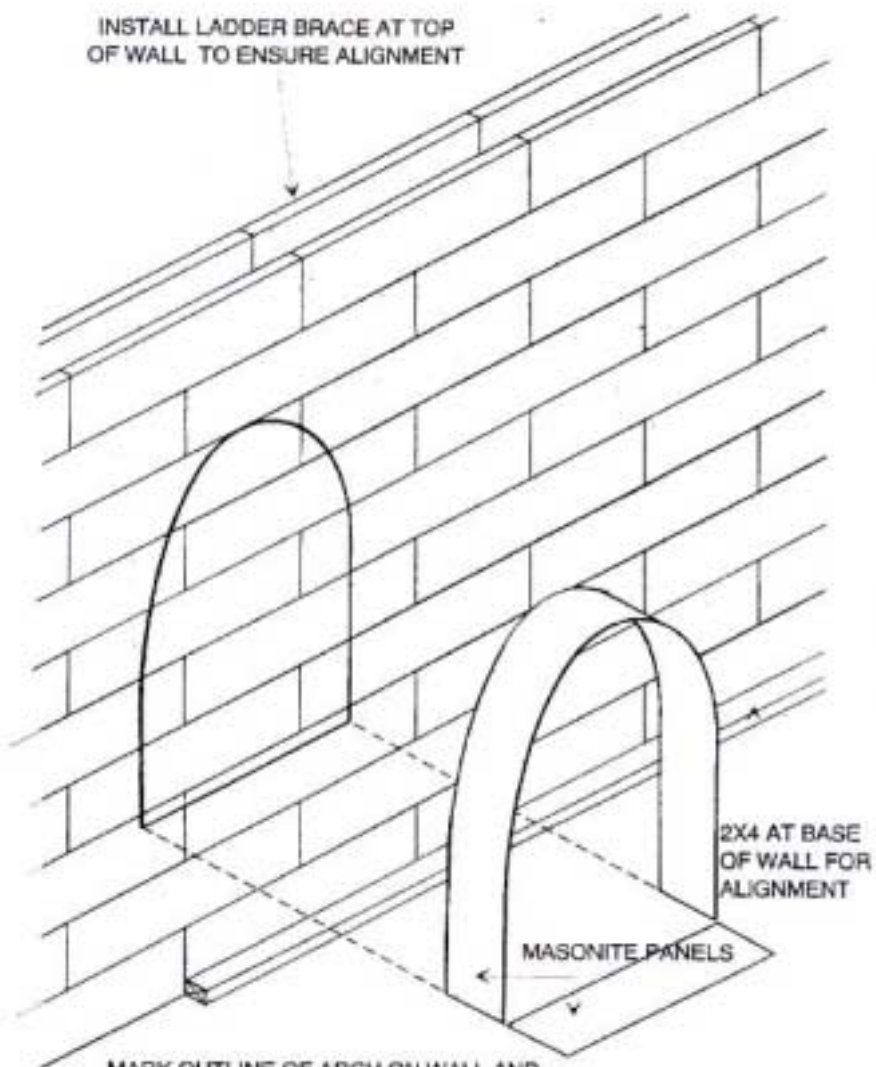

2X4 AT BASE
OF WALL FOR
ALIGNMENT

MASONITE PANELS

MARK OUTLINE OF ARCH ON WALL AND
CUT ALONG LINE MAKING SURE OF
ALIGNMENT OF THE CUT ON OPPOSITE
SIDE OF WALL. SLIDE THE MASONITE
PANELS INTO POSITION LEAVING THE
BLOCKS IN PLACE. CARE SHOULD BE TAKEN
WHEN PLACING REINFORCING STEEL
SO AS NOT TO CONFLICT WITH ARCH

ARCHED OPENINGS

ALL SERIES

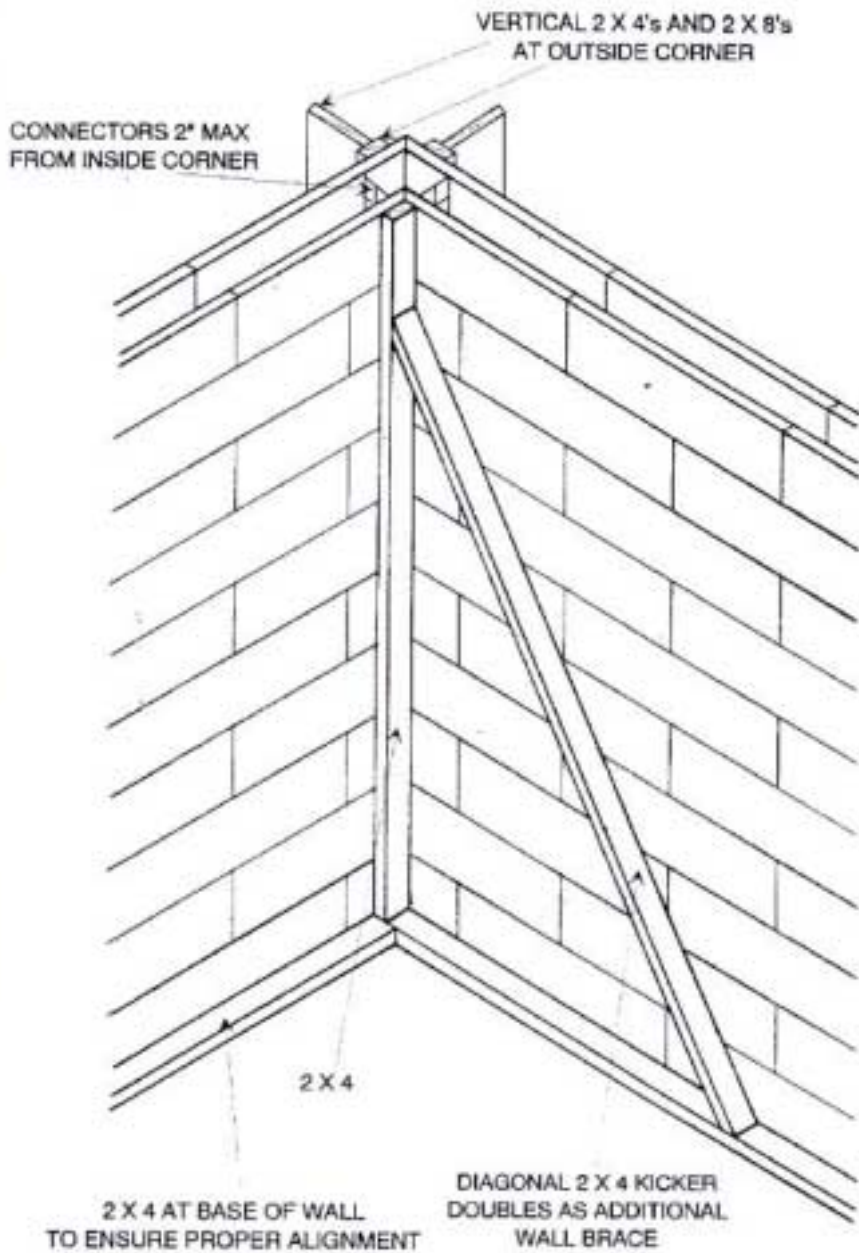

CORNER BRACING

VWF SERIES CORNER

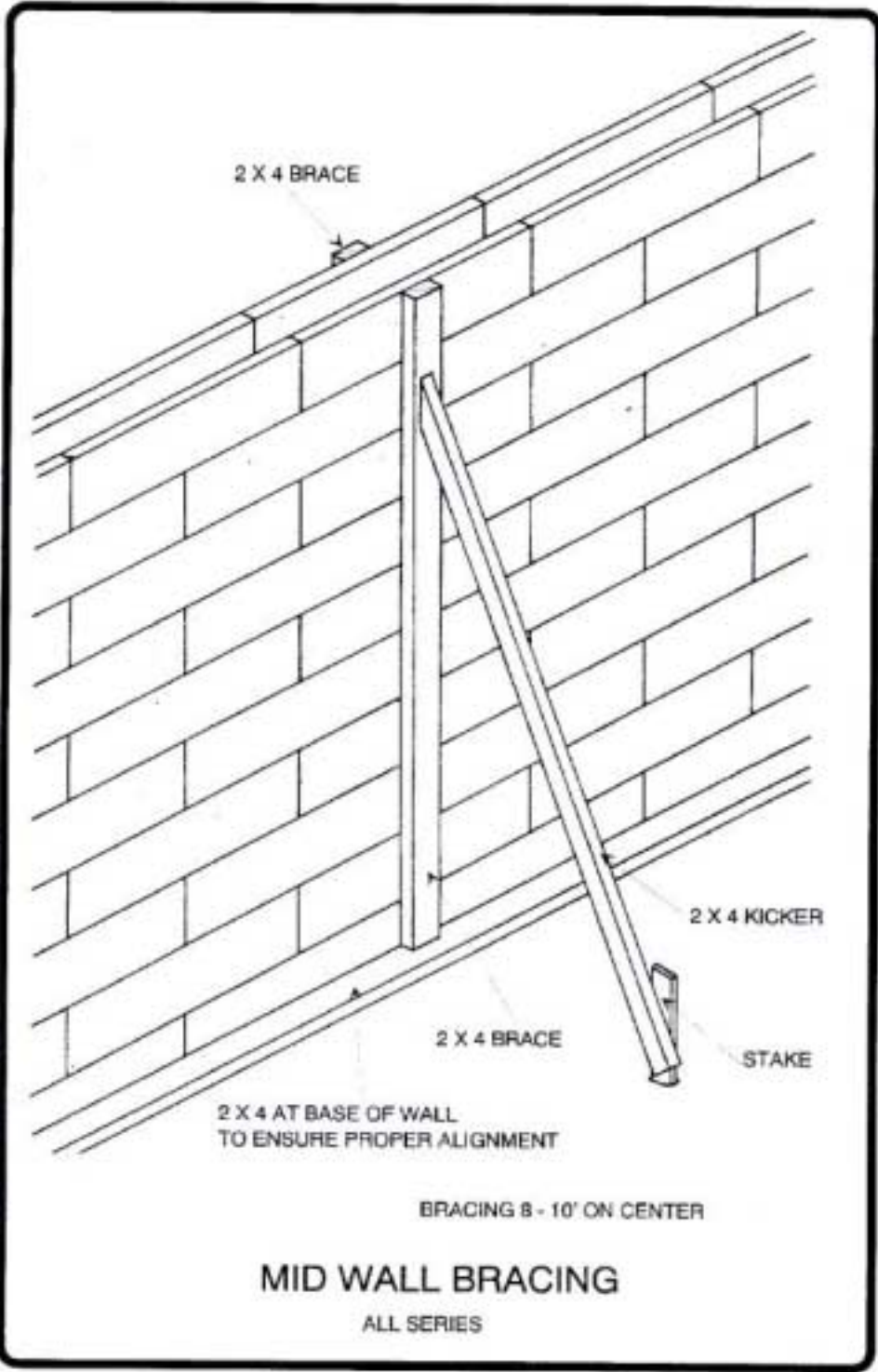

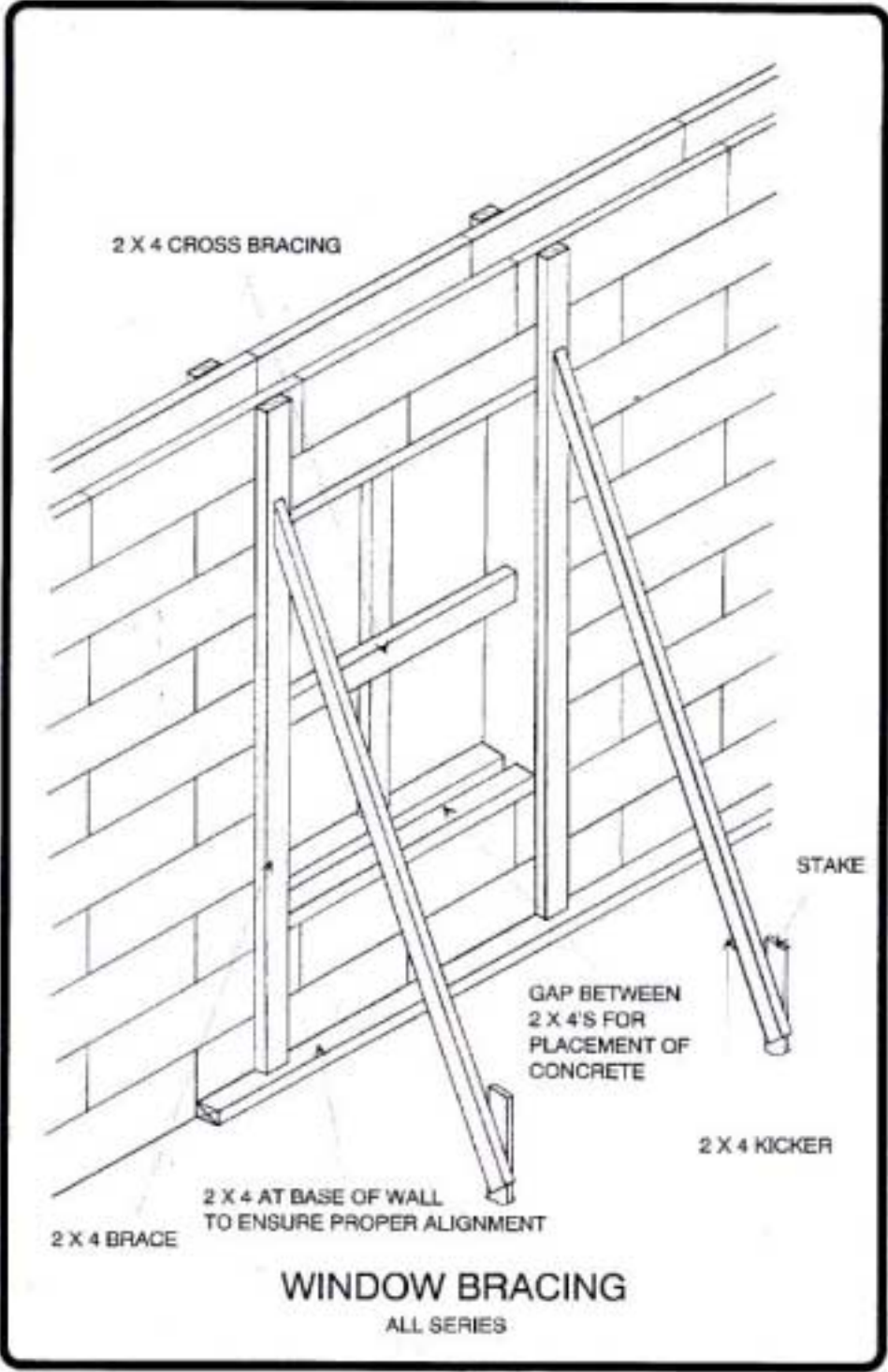

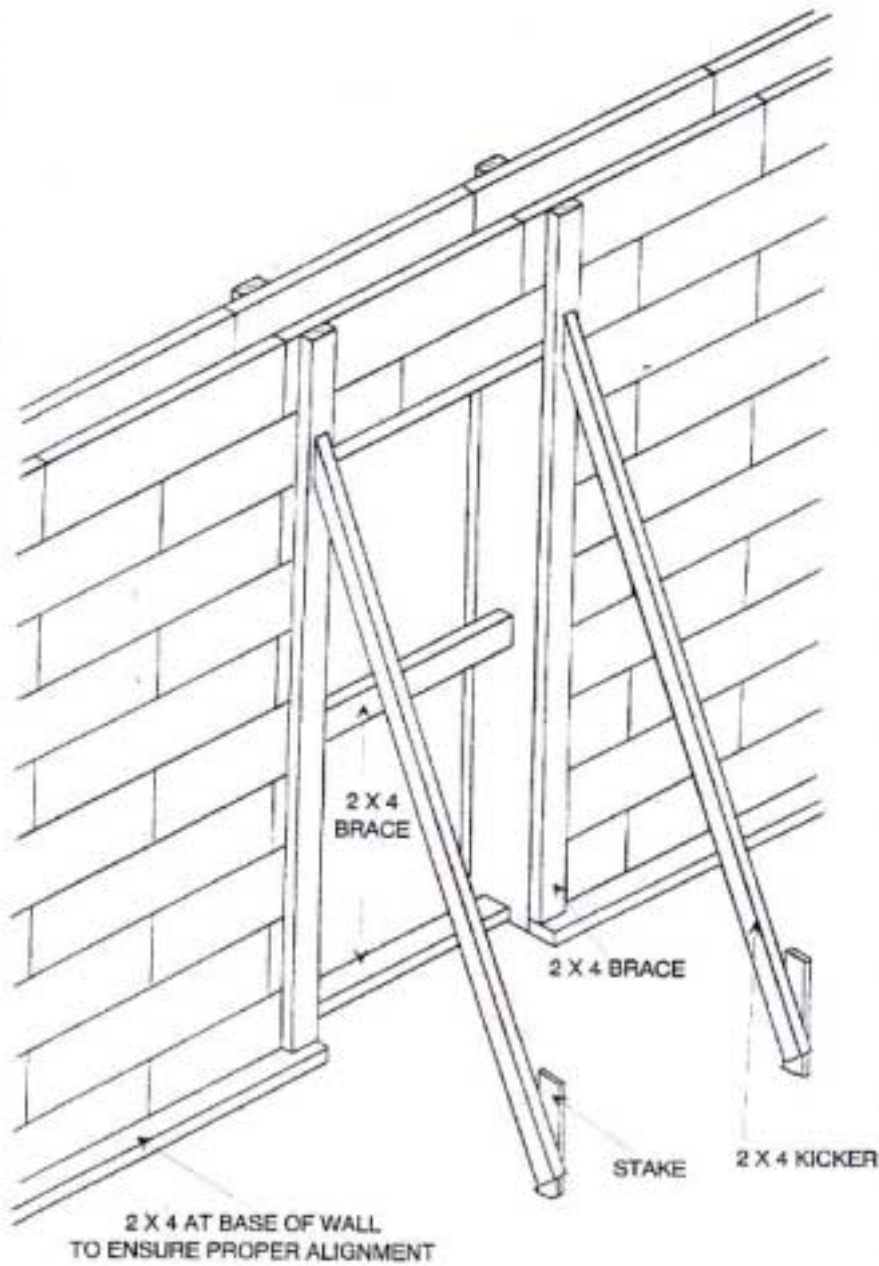

DOOR BRACING

ALL SERIES

CHAPTER 4

Interior Finishes



Attach drywall to our SmartTach or plastic connectors.



Corbels on the inside can be used for bearing joists, etc.

Chapter 4 INTERIOR FINISHES

This chapter addresses the methods of attaching an approved 15 minute thermal barrier over SmartBlock insulating forms as required by Chapter 26 of the 1997 UBC.

4.1 Gypsum Wall Board

All habitable areas of structures built with a SmartBlock insulating forms are required to be separated from the EPS by a thermal barrier having an index of 15. (See UBC Chapter 26.) The most common method is the use of gypsum wall board (GWB), also referred to as drywall. A minimum thickness of 1/2" is required to meet this condition. The 1997 UBC Chapter 25, which outlines the conventional methods of attaching drywall, requires that screws or nails be attached, as a minimum, 18" on center whether the drywall is attached horizontally or vertically.

4.1.1 Metal Clips

At present, the UBC does not specifically address attaching drywall to SmartBlock insulating forms. The UBC does state, however, that a test can be used as an alternative to the standard methods of attachment for thermal barriers. SmartBlock insulating forms were tested using metal clips that provide mechanical attachment with the concrete and a fastening surface for drywall screws.

4.1.2 The SmartTach Anchor System

SmartTach Anchor System is a fast, easy and secure way to attach gypsum wallboard, siding, lath, baseboard and other surfacing materials to SmartBlock™ walls.

SmartTach Anchors are 20 gauge "L" shaped galvanized steel, with a 2-inch square plate connected to a tapered, 3.6-inch long insert that slides through the foam SmartBlock wall. Prior to the pour, in order to achieve mechanical attachment with the concrete, a minimum of four 20-gauge galvanized, 2" wide clips (sold under the product name SmartTach™) are imbedded, through SmartBlock, into the concrete. The drywall is attached to the SmartTach with 3/4" minimum self tapping drywall screws 12 inches on center. It is strongly recommended that drywall adhesive compatible with EPS be used to attach the remaining portion of the drywall to the SmartBlock insulating forms or additional screws at reasonable spacing. Finishing of the drywall, such as drywall tape and topping mud, should be done in accordance with conventional practice.

SmartTach Anchors are pushed through the foam prior to pouring, and are held in place by the cured concrete. The system provides mechanical attachment of gypsum wallboard, siding, lath, baseboard and other surfacing materials once the concrete is in place.

The SmartTach Anchor System is packaged in a box that contains 240 SmartTach Anchors.

For more information about SmartTach anchors, see your local SmartBlock distributor or call 1-800-CONFORM

4.1.3 Instructions for installing SmartTach™

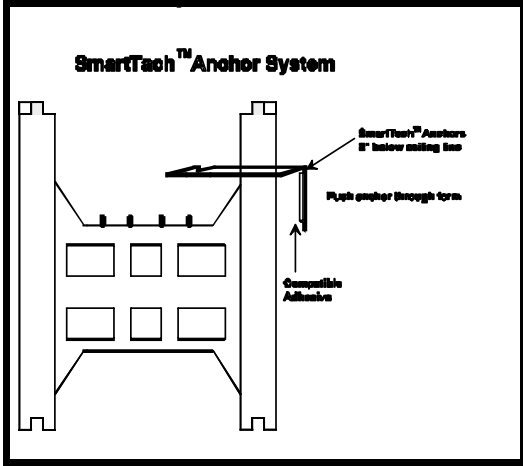

Step 1: Before pouring concrete, place a 1" daub of compatible adhesive on the back of the tab and install SmartTach 2" below the ceiling line 12" on center.

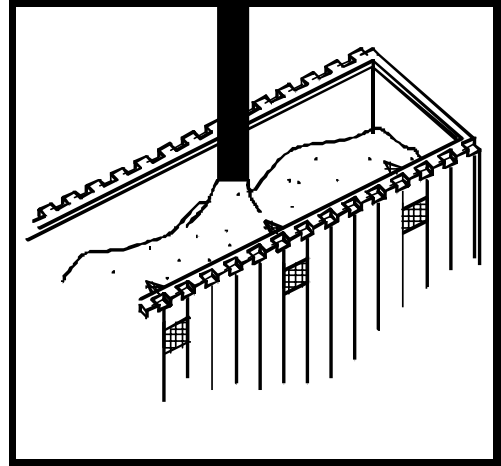

Step 2: Place concrete in SmartBlock™ forms. The protruding tip creates a mechanical bond between the concrete and the SmartTach.

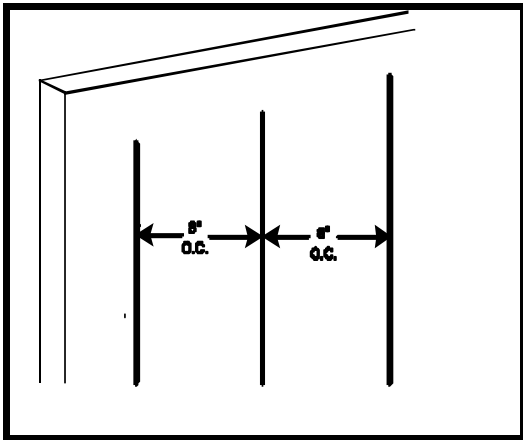

Step 3: Apply compatible adhesive to the back of the wallboard in 3/8" continuous beads 8" on center, or in 2" diameter daubs 16" on center in each direction or as directed by your engineer or building official.

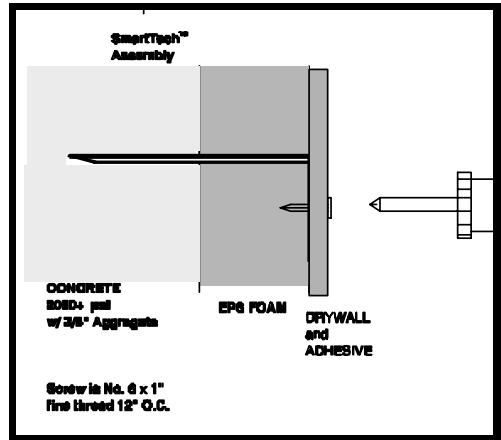

Step 4: Install wallboard vertically and attach it to each SmartTach with minimum 1" long self-tapping screws. Finish wallboard with tape and joint compound as in conventional practice.

4.1.3 Other Attachment Methods

Attaching drywall to the top wood plate instead of the metal strip described above should be sufficient to achieve the required thermal barrier. In order to achieve the required 15 minute thermal barrier over SmartBlock insulating forms as stipulated in Section 1713 of the 1991 UBC, you need only attach the drywall to the top strip. No other attachment is required although use of a drywall adhesive to assure a smooth and problem free surface is strongly recommended.

CHAPTER 5

Doors and Windows



Doors and windows are set into bucks locked into the solid concrete.



Flash windows with a membrane just as usual.

Chapter 5: DOORS AND WINDOWS

This chapter describes the installation of doors, windows and crawl space access for structures built with the SmartBlock insulating forms.

5.1 Frames

Doors and windows should be cut into the foam during installation of the SmartBlock insulating forms. Rough opening sizes must consider additional allowances for the frame described below.

Door and window frames should be of 2" x PTDF, foundation grade redwood or other approved treated lumber. It is recommended that oversized frame material be used and "ripped-down" to desired size to eliminate any dead space between frame and finish material.

One recommended frame attachment procedure is to use 3/8" diameter x 6" machine bolts in a staggered configuration leaving the nuts and washers on to resist pull-out of the bolts. The bolt heads shall be countersunk into the frame with a minimum amount of frame removed for a flush fit after washer and head are inlaid. An alternate method is to use 1/2" diameter x 8" anchor bolts set so the nut and washer will inlay flush at the frame with care taken so as not to allow the end of the bolt to extend beyond the face of the frame. See Detail 18.0.

5.2 Reinforcing Steel

Reinforcing steel is required to surround all openings in the following manner: 2-#5 reinforcing steel bars are required both horizontally and vertically around all openings, and must extend a minimum of 24" beyond the corner of that opening. In the case of the restricted area past the corner of an opening, the bar may be bent to tie to the nearest horizontal or vertical reinforcing bar.

CHAPTER 6

Exterior Finish Materials



Use a membrane waterproofing or equivalent below grade.



Above grade use stucco, stone or brick veneers, architectural detailing, etc.

Chapter 6 EXTERIOR FINISH MATERIALS

The exterior, both above and below grade, of SmartBlock insulating forms must be covered with a protective and waterproof finish after the reinforcing steel and concrete have been placed. This chapter describes exterior finishes that may be applied to SmartBlock insulating forms.

6.1 Below Grade Waterproofing

SmartBlock insulating forms must be waterproofed in below grade applications. Section 6.1.4 contains an approved list of waterproofing products for SmartBlock insulating forms.

SmartBlock insulating forms absorb only 2% by volume in water. In addition, water vapor transmission allows water to flow through the block. In a below grade structure, water vapor transmission will damage the interior drywall, causing it to warp and discolor. In the case of a retaining wall, water vapor transmission caused by inadequate waterproofing will cause the stucco on the exterior to discolor and possibly to spall off the wall.

EPS is a petroleum by-product that will dissolve when placed in contact with solvents, keytones, esters, and pitches. ***It is very important when selecting a waterproofing product that it is checked for compatibility with EPS.*** If you are concerned with the compatibility of a waterproofing product with EPS, call your material distributor or take a small portion of the product and apply it to a section of a SmartBlock insulating form. If you notice any disfigurement of the EPS (shrinkage, warping, etc.) within 24 hours, select a different waterproofing product.

There are many waterproofing products that work well with SmartBlock insulating forms. Most waterproofing failures are due to improper application, so waterproofing should be applied according to the manufacturers' instructions.

Waterproofing must be applied thoroughly to cover the SmartBlock insulating form wall leaving no holes or voids. Any pinholes or voids will permit moisture to infiltrate the wall. Particular attention should be given to assure that the joints and seams of the forms are sealed.

There are three common types of waterproofing used on EPS: Liquid emulsified products, sheet goods (membranes) and acrylic based cementitious products.

6.1.1 Liquid Emulsified Products

Liquid emulsified products work well in confined work spaces. The surface of the SmartBlock insulating forms must be clean and thoroughly dry before the waterproofing is applied. To test for dryness, tape a 4" square of aluminum foil to the EPS surface of the form being sure to tape the perimeter edges completely to prevent moisture escape. Allow the foil to remain undisturbed for 24 hours. Remove the tape carefully, and turn over the aluminum foil. If moisture is present on the foil then the surface requires additional drying. After thorough application of waterproofing (this may require 2 coats), protection board, usually 1/4" extruded polystyrene, must be applied over the waterproofing. This is required to prevent damage to the waterproofing material during backfilling. Waterproofing should be applied to a minimum of 6" above the planned finish grade in all applications.

6.1.2 Sheet Goods

Sheet goods also provide an effective method of waterproofing. The EPS exterior of the SmartBlock insulating forms must be clean and thoroughly dry, as required for liquid emulsified waterproofing. Sheet goods are placed on the wall, then the seams must be sealed with an adhesive strip. Do not use a system that requires the seams to be torch sealed as this may cause the SmartBlock insulating forms to melt. The same use and application of protection board is required as with the emulsified materials.

6.1.3 Acrylic Based Cements

Cement products that contain acrylic bases are also commonly used for waterproofing. The application is the same as for emulsified materials except that this material may be colored and may be applied to the entire wall both above grade and below grade. The main benefit to this particular type of application is in its aesthetic appearance. However, because it is a cement product it does not have the same expansion and contraction and freeze thaw durability as the other methods.

6.1.4 *Compatible Waterproofing Products—updated August 2002*

NOTE: Any product that is certified by its manufacturer to be compatible with EPS, such as the products listed below, may be used with SmartBlock forms. American ConForm Industries makes no endorsement or guarantee for such products, or for the product listed below.

MANUFACTURER	PRODUCT NAME	DESCRIPTION
Armtec Limited 33 Centennial Rd. Orangeville, Ontario CANADA L9W 1R1 519 -942 -2643 800 -265 -7622	Platon – Foundation Protector System	Air gap plastic membrane used to protect any type of wall system below the grade
Union Carbide Corp. 410 Gregson Drive Cary, NY 27511 (914) 345 -5300	BIPCO 40-W Watershield	Acrylic Elastomeric
MULTICOAT Corp. 1565 Sunflower Ave. Costa Mea, CA 92626 (714) 7 54 -1212 Fax (714) 754 -8996	Slatex System	Above And Below Grade Waterproofing System
W.R. Meadows, Inc. 60 Teal Court P.O. Box 97 Benicia, CA 94510 (707) 745 -6666	Mel-Rol	Membrane Waterproofing Liquid Emulsion
Crossfield Products 3000 E. Harcourt Stree t Rancho Dominguez, CA 90221 (310) 886 -9100	Miracote Liquid Membrane	Neoprene Emulsion
Polyguard Products, Inc. P.O. Box 755 Ennis, Tx. 75119 (800) 541 -4994	Polyguard	Membrane Waterproofing
Protecto Wrap Waterproofing Membranes 2255 S. Delaware Street Denver, CO 80223 (303) 777 -3001	PROTECTO WRAP	Membrane
The Quikrete Companies 1790 Century Circle NE Atlanta, GA 30345 (800) 282 -5828	Quikrete Heavy Duty Masonry Coating #1300	Acrylic Based Cement

Surewall Producers Council W.R. Bonsal Co. (800) 334 -0784 <u>CA Distributor:</u> Paragon Building Products 111 N. Vineland City of Industry, CA 91746 (818) 333 -2217	Surecoat	Acrylic Based Cement
Western Stucco Prod. Co. Inc. P.O. Box 968 6101 North 53rd Drive Glendale, AZ 95311 (623) 937 -9141	WESTERN ONE KOTE Stucco System	Acrylic Based Cement
La Habra Stucco 1631 W. Lincoln Ave. P.O. Box 3700 Anaheim, CA 92803 (714) 754 -1212	Krete Kote	Acrylic Based Cement
WR Grace & Co. 14901 N. Scottsdale Rd.306 Scottsdale, AZ 85254 (800) 852 -0568	Bituthene System 4000	Membrane Waterproofing
Highland Stucco and Lime 15148 Oxnard Street Van Nuys, CA 91411 (818) 785 -3131	WIRE TEX Stucco System	Acrylic Based Cement
Armtec Limited 33 Centennial Rd. Orangeville, ON L9W 1R1 (519) 942 -2643 (800) 265 -7622	BIGO	Drainage mat- air gap membrane

This list is only a portion of the products you could use. If the material is not listed, check with the manufacturer for compatibility and installation instructions.

6.2 Above Grade Exterior Finishes

This section describes recommended stucco finishes and coatings for use with the SmartBlock insulating forms. See Section 6.2.4 for stucco list.

6.2.1 Exterior Insulation Finish Systems

The first group of coatings are generically known as Exterior Insulation Finish Systems (EIFS). These systems are designed specifically for exterior EPS construction. The installation sequence for all EIFS coatings is as follows:

- 1) Liquid acrylic is mixed with common cement and applied to the EPS surface as a base coat.
- 2) Fiberglass mesh with ¼” grid is embedded into the base coat.
- 3) Colored liquid acrylic of varying textures is applied as a finish coat.

The average thickness of EIFS coatings is 1/8”. These systems have color fastness for up to ten years and are highly resistant to freeze-thaw conditions. In addition they provide a waterproof coating due to the acrylic additives. The main disadvantage of these systems is their low impact resistance to puncture. As a result, these coatings are often installed away from high traffic areas. EIFS coatings also tend to be more expensive than other finishes.

6.2.2 One Coat Stucco

“One coat stucco” is designed for use on exterior EPS construction. The installation sequence for one coat stucco finishes is typically as follows:

- 1) Apply pre-mixed base (cement, sand, and cut (approx. 3/8”) acrylic fibers) to the EPS surface with either a trowel or plaster application gun.
- 2) Fiberglass mesh, with a ¼” wide grid may be imbedded in the base in areas of high traffic (below 6’).
- 3) Apply desired pigment box, also known as color packs, over the base to achieve desired color finish.

The average thickness of these systems is 3/8" to 1/2". These finishes have high impact resistance, are very easy to apply and allow for many texture variations.

6.2.3 *Polymer Based Stuccos*

Direct liquid or polymer type additives are poured directly into a cement, sand and lime brown coat mixture. The installation procedure is as follows:

- 1) Combine cement, sand and lime per manufacturer's specification in standard cement mixer or plaster application gun.
- 2) Add specified amount of liquid polymer per manufacturer's specification in order to insure proper chemical bonding of cement base coat to EPS surface.
- 3) Fiberglass mesh, with 1/4" wide grid may be applied in areas of high traffic (below 6').
- 4) Finish in stucco-like textures, as required.
- 5) Apply finish coat of color integral stucco or paint with acrylic exterior paint.

The average thickness of this system is 3/8" to 1/2". These products are very easy to apply, have very high impact resistance, especially with applied mesh, and provide a solid waterproof coating due to the polymer additives.

6.2.4 *Compatible Exterior Stuccos—updated September 2000*

NOTE: Any product that is certified by its manufacturer to be compatible with EPS, such as the products listed below, may be used with SmartBlock forms. American ConForm Industries makes no endorsement or guarantee for such products, or for the product listed below.

E.I.F.S. are Exterior Insulated Finishing Systems.

MANUFACTURER	PRODUCT	TYPE
OMEGA PRODUCTS CORP. 2041 S. Susan Street P.O. Box 156 Santa Ana, Ca. 92704 (714) 556-3830	AKRO FLEX OMEGA STUCCO DIAMOND WALL TYRO BOND	E.I.F.S. One-Coat Acrylic Based Stucco
EXPO STUCCO PRODUCTS 7465 Carrol Road San Diego, CA 92121 (619) 566-4343	WALL BOND FIBER WALL	E.I.F.S One-Coat
DRYVIT SYSTEMS P.O. Box 539 Woodlake, CA 93286 (800) 556-7844	DRYVIT	E.I.F.S.
EL REY STUCCO COMPANY 4100 1/2 Broadway SE Albuquerque, NM 87102 (505) 873-1180	INSUL-FLEX	E.I.F.S.
MULTICOAT CORP. 1565 Sunflower Ave. Costa Mesa, CA 92626 (714) 754-1212	KRETE KOTE INSUL-STUCCO MULTICOAT STUCCO	E.I.F.S. Acrylic Based Stucco
MERLEX STUCCO MANUF. 2911 N. Orange-Olive Rd. Orange, CA (714) 637-1700	MERLEX STUCCO	E.I.F.S.
PERMA•CRETE 501 Metroplex Drive, Suite 115 Nashville, TN 37211 (615) 331-9200	PERMA•CRETE	Acrylic Based Cement

LA HABRA STUCCO1631 W. Lincoln Ave. P.O. Box 3700 Anaheim, CA 92803 (714) 774-1186	POLY BOND LA HABRA ONE COAT	Acrylic Based Cement One-Coat
QUIKRETE 1790 Century Circle NE Atlanta, GA 30345 (404) 634-9100	QUIKWALL	Acrylic Based Cement
PARAGON BUILDING PRODUCTS, INC.111 N. Vineland Ave. City of Industry, CA 91746 (909) 549-1155	SUREWALL SURFACE BONDING CEMENT SURECOAT MASONRY COATING	Acrylic Based Cement
THORO SYSTEM PROD.7800 N.W. 38th StreetMiami, Fl. 33166 (800) 243-6739	THOROWALL	E.I.F.S.
US GYPSUM CO. 550 N. Brand Blvd. 12th Floor Glendale, CA 91203-1904 (909) 941-8850	USG EXTERIOR FINISH SYSTEM	E.I.F.S.
WESTERN STUCCO PROD.P.O. Box 9686101 North 53rd Drive Glendale, AZ 95311 (623) 939-9455	WESTERN ONE KOTE	One-Coat Acrylic Based Cement
HIGHLAND STUCCO 15148 Oxnard Street Van Nuys, CA 91411 (818) 785-3131	WIRE TEX	One-Coat Acrylic Based Cement
KING STUCCO CO. 1631 S. 10th Street San Jose, Ca. 95112 (408) 293-4008	XL Coat	E.I.F.S.

6.3 Compatible Adhesive List--updated July 1999

NOTE: Any product that is certified by its manufacturer to be compatible with EPS, such as the products listed below, may be used with SmartBlock forms. American ConForm Industries makes no endorsement or guarantee for such products, or for the product listed below.

PRODUCT	MANUFACTURER	NOTES
#77 Spray Adhesive	3M Corporation (612) 736-3238 (800) 480-1704	Spray
ACE Construction Adhesive	ACE Hardware (800) 347-4583	Mastic
DAP 2000 Construction Adhesive	DAP Inc. 855 N. Third Street Dayton, OH (800) 543-3840	Mastic
Enerfoam	Abisko Manufacturing, Inc. Richmond Hill, Ontario Canada, L4B 1E4 (800) 567-4447 ex. 43	Foam Adhesive System
Franklin Multi-Bond Solvent Free	Franklin International Bruck Street Columbus, OH (800) 877-4583 (614) 443-0241	Mastic
PL300 PL Premium	Chemrex, Inc. 889 Valley Park Drive Shakopee, MN 55379 (800) CHEMREX	Mastic
MD 200	Macklanberg-Duncan 4041 N. Santa Fe Oklahoma City, OK 73118 (800) 654-8454 (405) 528-4411	Mastic
Miracle DSA 40	Pratt & Lambert Specialty Prod. 75 Tonawanda Street Buffalo, NY 14207 (800) 876-7005	Mastic

This list is only a portion of the products you could use. If the material is not listed, check with the manufacturer for compatibility and installation instructions.

CHAPTER 7

Plumbing and Electrical



Route out foam for electrical and plumbing chases.



Service penetrations should be in prior to the pour.

Chapter 7 PLUMBING AND ELECTRICAL

7.1 Introduction to Plumbing and Electrical

Consideration of support services such as plumbing and electrical systems from the preliminary schematics phase through final construction, including regard for ease of installation, cost and future access requirements, can avoid many construction problems. Structural systems can be modified and interior chases and soffits can be incorporated to provide space and access necessary for years of satisfactory service. SmartBlock insulating form concrete walls share the same attributes as other solid masonry wall systems and must incorporate many of the same construction practices.

The following sections contain suggested methods to facilitate the installation of plumbing and electrical systems in SmartBlock insulating form walls. All design parameters must obey the rules of all applicable codes and regulations for all governing authorities having jurisdiction over the project.

7.2 Plumbing

7.2.1 Direct Embedment

Design parameters for pipes in SmartBlock insulating form concrete walls are similar to the design parameters for pipes in other solid masonry walls. Most building codes prohibit direct embedment of pipes in concrete walls and foundations to avoid damage from expansion and contraction of hot water pipes and from expansion, contraction and settlement of structural systems.

7.2.2 Protection of Pipes

Code compliance through varying methods of protecting piping from the results of expansion, freezing and structural stresses is generally interpretative. Suitability of any particular method should be verified by local building officials during the design phase. Some methods now in use, although legal in some jurisdictions, are not recommended by the manufacturer. Included, by example, would be wrapping pipes in layers of building paper or any other method that would restrict future access to that pipe. Some of these methods may be suitable for commercial applications, but would be inappropriate in residential construction.

7.2.3 Installation Recommendations

The details in this manual should serve most conditions and are configured to show “extreme case” installation requirements. See Details 19.0 and 19.0A. “Extreme case” in this instance is considered to be a 4” ABS soil line, running vertical past the floor ledger, assuming 5” across the hub. Note: The use of 4” cast iron soil pipe may require the structural abandonment of an entire vertical cell and specific engineering consideration would be necessary.

To embed pipes in SmartBlock SF10 Series walls, chases should be cut through the foam blocks at the foam bridges. This method maintains the structural integrity of the vertical cell and horizontal bond beam at the floor level. (This wall section should be shored until the concrete is cured.) This location provides maximum concrete retention in the vertical cells and will not affect the location of vertical reinforcing bars. The benefit of this system is that exact pipe location is not necessary at the time of setting the vertical foundation reinforcing, as would be, if an entire vertical cell were eliminated. When using this system for large pipe, a vertical section of foam is removed to house a portion of the pipe. Since floor ledgers are inset into the foam and secured directly to the concrete, vertical pipe runs conflict in this area. Ledgers may be

notched at this location, provided structural analysis has been performed as with any alteration of structural support elements. Doubling the anchor bolts at either side of the notch should be sufficient, although confirmation should be sought by the project architect or engineer.

Location of any structural reinforcing or fastening members in relation with the chase shall be verified to meet all structural requirements as to clearances, embedment, continuous application, etc.

Insulation of pipes in exterior walls may be required to protect pipes from freezing. The remaining layer of polystyrene foam at the exterior may be sufficient to prevent freezing in milder climates. Insulation of pipes may also be desired to dampen sound transmission. In most cases, foam insulation fit onto the clearance space of the chase should be sufficient to reduce noise and should not effect free movement of the pipe. These considerations should be addressed with local building officials before application.

Installation of smaller pipes, including copper supply lines, may be channeled directly into the foam. This is accomplished by using a router or heat tool to cut enough foam out providing a channel of sufficient width and depth to house the pipe. When using this system, pipes must be protected from mechanical damage. This may be accomplished by providing a section of metal strap, no less than 1/16" thick, over the channel after the pipe is secured.

7.2.4 *Support of Pipes*

All pipes shall be supported as required by local codes, considering pipe alignment and the weight of the piping and contents. Since pipes are to be installed after concrete is set, support must be of an approved concrete fastening system.

Drilled concrete screw type anchors are recommended, although any approved concrete fasteners may be used. Power actuated nails are not recommended with SmartBlock SF10 Series forms due to the possibility of firing pins through the foam bridges.

7.3 Electrical

Electrical wiring can easily be placed into walls built with SmartBlock insulating forms. Place deep concrete junction boxes through the wall of the form at desired locations prior to pouring concrete. This will allow for the mechanical attachment of the box to the concrete. Also prior to pouring, run conduit to the primary junction boxes from the future location of the joist bay above. The junction box will also serve as the switch location for the room's "half hot" plug or ceiling mounted fixture. Check with local building department for specific sizes and requirements.

From the junction box, one Romex wire will be used for the switch and "half hot" plug; another for the other electrical outlets required in the room. After the pour, these wires can be placed in chases cut into the wall of the forms from the main junction box. Create a chase for the Romex with a router or heat tool (a heat tool is faster, cleaner and more accurate) making larger cut outs at the desired locations for the outlets. If holding a straight line is difficult with the router or heat tool, snap a chalk line to follow a course.

To protect the Romex from nails or screws, a number of methods may be used. One method is to cover the Romex with a minimum 16 gauge continuous “C” channel pressed flush with the surface of the SmartBlock insulating form. As an alternative, if the foam is cut out to a minimum of 1½”, the Romex can be glued in place with an adhesive or spray foam applied every 24” on center. You can also replace the cut out foam piece over the Romex, pressing or rasping the foam flush with the wall, so the Romex will not back out of the slot. Either method will give a minimum 1½” protection, after addition of the drywall, to properly protect it from any penetration.

When using SF10 Series forms, locating outlet boxes on the bridges after concrete placement will permit use of a deeper box. If boxes cannot be located on the bridges or if VWF Series forms are installed, a shallow outlet will be required. See Detail 20.0 on page 88.

CHAPTER 8

Manufacturers Specifications



SmartBlock conforms to all building codes.



Angles or curves are easy with SmartBlock.

Chapter 8 MANUFACTURERS SPECIFICATIONS

8.1 Manufacturers Technical Specifications

Property	Test or Standard	Product	Value
Part Size		SF10	10" x 10" x 40"
		12VWF4	8" x 12" x 40"
		12VWF6	10" x 12" x 40"
		12VWF8	12" x 12" x 40"
		12VWF10	14" x 12" x 40"
		12VWF12	16" x 12" x 40"
Average EPS Wall Thickness		SF10	1.75"
		VWF	2.125"
Concrete Wall Thickness		SF10	6.5"
		12VWF4	3.75"
		12VWF6	5.75"
		12VWF8	7.75"
		12VWF10	9.75"
		12VWF12	11.75"
Color		EPS forms	Light gray
		VWC4	Yellow
		VWC6	Blue
		VWC8	Red
		VWC10	Black
		VWC12	Grey
Insulation Value	ASTM C-236 Fully grouted	SF10	0.057 U R-22 Equivalent*
	ASTM C-177 ASTM C-518	12VWF4	0.048 U R-24 Equivalent*
	ASTM C-177 ASTM C-518	12VWF6	0.047 U R-24 Equivalent*
	ASTM C-177 ASTM C-518	12VWF8	0.046 U R-24 Equivalent*
	ASTM C-177 ASTM C-518	12VWF10	0.045 U R-24 Equivalent*
	ASTM C-177 ASTM C-518	12VWF12	0.044 U R-24 Equivalent*
STC Rating (inc. 2 layers 1/2" Gypsum drywall)		SF10	STC-52+
		VWF4	STC-44+
		VWF6	STC-55+
		VWF8	STC-58+
		VWF10	STC-59+
		VWF12	STC-60+
Flame Spread	ASTM E-84 UBC Standard 42-1		10 (5##)

Smoke Development	ASTM E-84 UBC Standard 42-1	45-125 (75##)
-------------------	--------------------------------	---------------

Property	Test or Standard	Product	Value
15 Minute Thermal Barrier	UBC Standard 17-5, 1991 UBC Section 1713(d), 1991		Compliance (UC Berkeley)
Exposure in a crawl space	UBC Section 1713(d)D, 1991		Compliance (Southwest Research Institute)

SmartBlock EPS Specifications		Value at 1.5 PCF	Value at 2.0 PCF
Flexural Strength	ASTM C-203	50psi	75psi
Compressive Strength	ASTM D-1621	25psi	33psi
Density	ASTM C-303	1.5 PCF	2.0 PCF
Shear Strength	ASTM C-273	32psi	37psi
Tensile Strength	ASTM D-1623	22psi	27psi
Water Vapor Transmission	ASTM C-355	0.7-1.4 PERM/IN	0.7-1.4 PERM/IN
Water Absorption	ASTM C-272	<2% by volume	<2% by volume
Capillarity		None	None
Coefficient of thermal expansion	ASTM D-696	0.000035 in/in/°F	0.000035 in/in/°F
Flash ignition temperature	ASTM D-1929	675 °F	675 °F
Self ignition temperature	ASTM D-1929	675 °F	675 °F
Maximum Temperature		165 °F	165 °F
BTU Content	ASTM D-2015 NFPA-259	17,000 BTU/ lb.	17,000 BTU/ lb.

***The R-value equivalent stated refers to a comparison of a SmartBlock insulating form wall versus wood framing 16" on center with the cavities filled with fiberglass batt insulation. This is the "standard" that is used when comparing R-values and thermal insulation factors for use with the various energy agencies.**

8.2 Energy Analysis

The following sections describe the insulation values that are associated with the SF10 Series and the VWF Series forms.

8.2.1 SF10 Series

Because the SF10 Series form has integral EPS bridges, most of the state energy offices have required that the SF10 Series be tested in accordance with ASTM C-236. This is a total wall assembly test rather than the conventional method which tests each individual component. The wall has a tested U-value of 0.057 (A U-value is the inverse of an R-value when used as a total wall assembly.)

The U-value of 0.057 exceeds all state and local insulation requirements for the entire United States for both above and below grade applications. It is the equivalent of a wood framed wall with studs 16" on center having the cavities filled with R-22 fiberglass batt insulation. In many cases this can qualify for insulation rebates. It is recommended that you check with your local power or utility company to determine if you are eligible for insulation rebates for using SmartBlock.

8.2.2 VWF Series

Because the two side panels of the VWF Series are essentially flat pieces of EPS, ASHRAE values are used in calculating the insulation values. The value for 2.0 PCF density EPS is 4.40 R/inch. The average thickness of each panel is 2.125". Therefore, each panel has a value of 9.35 R. They are 0.048 U for the VWF4, 0.047 U for the VWF6, 0.046 U for the VWF8, 0.045 U for the VWF10 and 0.044 U for the VWF12.

The U-values of 0.048, 0.047, 0.046, 0.045 and 0.044 exceed all state and local insulation requirements for the entire United States for both above and below grade applications. These values are the equivalent of a wood framed wall with studs 16" on center having the cavities filled with R-24 fiberglass batt insulation. In many cases this can qualify for insulation rebates. It is recommended that you check with your local power or utility company to determine if you are eligible for insulation rebates for over insulating your structure.

8.3 Sound Transmission

Because SmartBlock insulating form walls are essentially concrete, they work very well as sound walls. The ratings for these walls are stated in terms of an STC (Sound Transmission Class). The minimum STC Rating for sound walls as stated by the UBC is 45.

The ratings for SmartBlock insulating form concrete walls are as follows:

SF10	STC Rating	52+
VWF4	STC Rating	48+
VWF6	STC Rating	55+
VWF8	STC Rating	58+
VWF10	STC Rating	59+
VWC12	STC Rating	60+

Therefore, the SmartBlock insulating form concrete walls exceed the minimum requirements for sound walls.

8.4 Concrete Specifications

SF10 Series

Minimum Strength (ICBO)	2,000 psi.
Minimum Strength (BOCA)	2,500 psi.
Maximum Aggregate Size	3/8" pea gravel
Slump	6"

VWF Series

Minimum Strength (ICBO)	2,000 psi.
Minimum Strength (BOCA)	2,500 psi.
Maximum Aggregate Size	3/8" pea gravel
Slump	6"

8.6 Block Estimation

STANDARD BLOCK SIZE: 10" X 10" X 40"
COVERAGE: 2.78 SQUARE FEET
CONCRETE CAPACITY: 1.35 CUBIC FEET OF CONCRETE

1 cubic yard of concrete fills 20 SF10 Series SmartBlock insulating forms
20 SF10 Series SmartBlock insulating forms covers 55.6 square feet
1 square foot takes .48 cubic feet of concrete

USE THE FOLLOWING FORMULA TO DETERMINE HOW MANY SMARTBLOCK INSULATING FORMS YOUR JOB WILL REQUIRE

1 course wall (10") - 0.3
2 course wall (20") - 0.6
3 course wall (30") - 0.9
4 course wall (40") - 1.2
5 course wall (50") - 1.5
6 course wall (60") - 1.8
7 course wall (70") - 2.1
8 course wall (80") - 2.4
9 course wall (90") - 2.7
10 course wall (100") - 3.0

EXAMPLE: If you had 100 lineal feet of wall going 3 courses (30") high, use the formula numbers above (in this example, 0.9) to determine how many blocks you will need:

of lineal feet x 0.9 (for a 3 course wall) = number of blocks

IF IT WERE 100 LINEAL FEET, THEN:

100 lineal feet x 0.9 = 90 blocks needed for that job

FIGURING AMOUNT OF END PIECES NEEDED

Every time you make a 90 degree corner, each corner will take one (1) end piece set per course.

Example: 3 course wall (30") would take three end pieces.

8.7 Tools and Materials

SMARTBLOCK INSULATING FORMS

TOOLS AND MATERIALS REQUIRED:

1. Rebar cutter and bender
2. Tie wire and wire cutters
3. Adobe standoffs*
4. 1" x 3" x 48" wood stakes*
5. Box clips*
6. Hand saw and keyhole saw
7. Sledgehammer*
8. Line
9. Spray glue
10. SmartBlock end pieces
11. SmartBlock insulating forms
12. Tape measure
13. Builder's level
14. 1" x 3" x 9 1/4" spreader
15. Line or boom pump with a 2" hose (and an "S" bend, if using a boom pump)
16. 3/8" pea gravel with a 6 sack mix
17. Plumb bob
18. Flag nails*
19. SmartBlock tape

* - Will probably not be necessary if the footings are pre-poured.

8.8 Radius Cut Outs

SmartBlock insulating form walls are easily manipulated to produce radiused and curved walls. By cutting out portions of the interior cell, between the bridges, a curved wall can be formed.

For inside radius cuts, the formula for determining the amount of area to cut out of each cell is as follows:

$$\text{Cut out per cell in inches} = \frac{\text{block width} \times \text{cell length (in inches)}}{\text{radius (inside)} + \text{block width (in inches)}}$$

For outside radius cuts, the formula is as follows:

$$\text{Cut out per cell inches} = \frac{\text{block width} \times \text{cell length (in inches)}}{\text{radius (outside)}}$$

It is important to remember that each block will have four cuts and that all cuts must be the same in order to achieve a smooth curved wall appearance.

The chart on the following page contains cut out dimensions (in inches) per cell based on commonly used radius amounts:

SmartBlock RADIUS CHARTS

Inside Radius Chart

INSIDE RADIUS IN FEET	SF10	VWF 4	VWF 6	VWF 8	VWF 10	VWF 12
4	N/A	N/A	N/A	N/A	N/A	N/A
5	N/A	N/A	N/A	N/A	N/A	N/A
6	1.22	1.00	1.22	1.43	1.63	1.82
7	1.06	0.87	1.06	1.25	1.43	1.60
8	0.94	0.77	0.94	1.11	1.27	1.43
9	0.85	0.69	0.85	1.00	1.15	1.29
10	0.77	0.63	0.77	0.91	1.04	1.18
12	0.65	0.53	0.65	0.77	0.89	1.00
14	0.56	0.45	0.56	0.67	0.77	0.87
16	0.50	0.40	0.50	0.59	0.68	0.77
18	0.44	0.36	0.44	0.53	0.61	0.69
20	0.40	0.32	0.40	0.48	0.55	0.63
22	0.36	0.29	0.36	0.43	0.50	0.57
25	0.32	0.26	0.32	0.38	0.44	0.51
30	0.27	0.22	0.27	0.32	0.37	0.43
35	0.23	0.19	0.23	0.28	0.32	0.37
40	0.20	0.16	0.20	0.24	0.28	0.32

Outside Radius Chart

OUTSIDE RADIUS IN FEET	SF10	VWF 4	VWF 6	VWF 8	VWF 10	VWF 12
4	N/A	N/A	N/A	N/A	N/A	N/A
5	N/A	1.33	N/A	N/A	N/A	N/A
6	1.39	1.11	1.39	N/A	N/A	N/A
7	1.19	0.95	1.19	1.43	N/A	N/A
8	1.04	0.93	1.04	1.25	1.46	N/A
9	0.93	0.74	0.93	1.11	1.30	1.48
10	0.83	0.67	0.83	1.00	1.17	1.33
12	0.69	0.56	0.69	0.83	0.97	1.11
14	0.60	0.48	0.60	0.71	0.83	0.95
16	0.52	0.42	0.52	0.63	0.73	0.83
18	0.46	0.37	0.46	0.56	0.65	0.74
20	0.42	0.33	0.42	0.50	0.58	0.66
22	0.38	0.30	0.38	0.45	0.53	0.61
25	0.33	0.27	0.33	0.40	0.47	0.53
30	0.28	0.22	0.28	0.33	0.39	0.44
35	0.24	0.19	0.24	0.29	0.33	0.38
40	0.21	0.17	0.21	0.25	0.29	0.33

CHAPTER 9

Design Details



SmartBlock is fast and easy when forming complex designs.



Design SmartBlock like any flat, solid poured-in-place wall.

Chapter 9 DESIGN DETAILS

The following chapter contains drawings, design details, and charts for recommended use with SmartBlock insulating forms. These drawings, design details, and charts are based upon generally approved design and engineering techniques and are intended **as guides only**.

Because specific conditions may vary, architects, engineers, and local building officials should be consulted for proper application in all SmartBlock insulating form projects.

9.1 Design Section

TABLE "A"

30 PCF ACTIVE SOIL PRESSURE

H	B	C	D	E	X BARS
3'	1'-9"	6"	-	-	#4 @ 20"
4'	2'-2"	6"	6"	9"	#4 @ 20"
5'	2'-9"	1'-0"	9"	1'-0"	#4 @ 20"
6'	3'-4"	1'-0"	1'-0"	1'-0"	#5 @ 20"

- Note: 1. Design is also based upon:
- a. Soil bearing capacity of 1000 PSF
 - b. Soil weight of 120 PCF
 - c. Passive pressure of 250 PSF
 - d. Coefficient of friction = 0.35
 - e. Consult with a local soil engineer or building department official to verify all soil values.
- 2.
- a. $f_y = 40,000$ psi for #4; $f_y = 60,000$ psi for #5 or larger
 - b. Consult with local building officials to verify conformance with minimum and maximum steel requirements.

TABLE "A"

35 PCF ACTIVE SOIL PRESSURE

H	B	C	D	E	X BARS
3'	1'-9"	6"	3"	6"	#4 @ 20"
4'	2'-3"	6"	8"	9"	#4 @ 20"
5'	3'-0"	1'-0"	10"	1'-0"	#4 @ 20"
6'	3'-8"	1'-0"	1'-4"	1'-0"	#5 @ 20"

- Note: 1. Design is also based upon:
- a. Soil bearing capacity of 1000 PSF
 - b. Soil weight of 120 PCF
 - c. Passive pressure of 250 PSF
 - d. Coefficient of friction = 0.35
 - e. Consult with a local soil engineer or building department official to verify all soil values.
- 2.
- a. $f_y = 40,000$ psi for #4; $f_y = 60,000$ psi for #5 or larger
 - b. Consult with local building officials to verify conformance with minimum and maximum steel requirements.

TABLE "A"
40 PCF ACTIVE SOIL PRESSURE

H	B	C	D	E	X BARS
3'	1'-1"	6"	4"	6"	#4 @ 20"
4'	2'-6"	6"	10"	9"	#4 @ 20"
5'	3'-2"	1'-0"	1'-2"	1'-0"	#4 @ 20"
6'	3'-10"	1'-0"	1'-7"	1'-0"	#5 @ 20"

- Note: 1. Design is also based upon:
- a. Soil bearing capacity of 1000 PSF
 - b. Soil weight of 120 PCF
 - c. Passive pressure of 250 PSF
 - d. Coefficient of friction = 0.35
 - e. Consult with a local soil engineer or building department official to verify all soil values.
2. a. $f_y = 40,000$ psi for #4; $f_y = 60,000$ psi for #5 or larger
- b. Consult with local building officials to verify conformance with minimum and maximum steel requirements.

TABLE "A"
45 PCF ACTIVE SOIL PRESSURE

H	B	C	D	E	X BARS
3'	2'-0"	6"	6"	6"	#4 @ 20"
4'	2'-8"	6"	1'-0"	9"	#4 @ 20"
5'	3'-6"	1'-0"	1'-4"	1'-0"	#4 @ 20"
6'	4'-0"	1'-0"	1'-10"	1'-6"	#5 @ 20"

- Note: 1. Design is also based upon:
- a. Soil bearing capacity of 1000 PSF
 - b. Soil weight of 120 PCF
 - c. Passive pressure of 250 PSF
 - d. Coefficient of friction = 0.35
 - e. Consult with a local soil engineer or building department official to verify all soil values.
2. a. $f_y = 40,000$ psi for #4; $f_y = 60,000$ psi for #5 or larger
- b. Consult with local building officials to verify conformance with minimum and maximum steel requirements.

TABLE "A"
50 PCF ACTIVE SOIL PRESSURE

H	B	C	D	E	X BARS
3'	2'-2"	6"	9"	6"	#4 @ 20"
4'	2'9"	6"	1'-2"	9"	#4 @ 20"
5'	3'-6"	1'-0"	1'-6"	1'-0"	#5 @ 20"
6'	4'-3"	1'-0"	2'-0"	1'-6"	#5 @ 20"

- Note: 1. Design is also based upon:
- a. Soil bearing capacity of 1000 PSF
 - b. Soil weight of 120 PCF
 - c. Passive pressure of 250 PSF
 - d. Coefficient of friction = 0.35
 - e. Consult with a local soil engineer or building department official to verify all soil values.
2. a. $f_y = 40,000$ psi for #4; $f_y = 60,000$ psi for #5 or larger
b. Consult with local building officials to verify conformance with minimum and maximum steel requirements.

TABLE "A"
55 PCF ACTIVE SOIL PRESSURE

H	B	C	D	E	X BARS
3'	2'-2"	6"	9"	6"	#4 @ 20"
4'	2'-11"	6"	1'-3"	9"	#4 @ 20"
5'	3'-8"	1'-0"	1'-8"	1'-6"	#5 @ 20"
6'	4'-6"	1'-0"	2'-3"	1'-9"	#5 @ 20"

- Note: 1. Design is also based upon:
- a. Soil bearing capacity of 1000 PSF
 - b. Soil weight of 120 PCF
 - c. Passive pressure of 250 PSF
 - d. Coefficient of friction = 0.35
 - e. Consult with a local soil engineer or building department official to verify all soil values.
2. a. $f_y = 40,000$ psi for #4; $f_y = 60,000$ psi for #5 or larger
b. Consult with local building officials to verify conformance with minimum and maximum steel requirements.

TABLE "A"
60 PCF ACTIVE SOIL PRESSURE

H	B	C	D	E	X BARS
3'	2'-3"	6"	10"	6"	#4 @ 20"
4'	3'-2"	6"	1'-5"	1'-0"	#4 @ 20"
5'	3'-10"	1'-0"	1'-10"	1'-6"	#5 @ 20"
6'	4'-8"	1'-0"	2'-5"	2'-0"	#5 @ 10"

- Note: 1. Design is also based upon:
- a. Soil bearing capacity of 1000 PSF
 - b. Soil weight of 120 PCF
 - c. Passive pressure of 250 PSF
 - d. Coefficient of friction = 0.35
 - e. Consult with a local soil engineer or building department official to verify all soil values.
- 2.
- a. $f_y = 40,000$ psi for #4; $f_y = 60,000$ psi for #5 or larger
 - b. Consult with local building officials to verify conformance with minimum and maximum steel requirements.

TABLE "A"
65 PCF ACTIVE SOIL PRESSURE

H	B	C	D	E	X BARS
3'	2'-3"	6"	1'-0"	9"	#4 @ 20"
4'	3'-1"	6"	1'-6"	1'-3"	#4 @ 20"
5'	3'-11"	1'-0"	2'-0"	1'-6"	#5 @ 20"
6'	4'-9"	1'-0"	2'-7"	2'-0"	#5 @ 10"

- Note: 1. Design is also based upon:
- a. Soil bearing capacity of 1000 PSF
 - b. Soil weight of 120 PCF
 - c. Passive pressure of 250 PSF
 - d. Coefficient of friction = 0.35
 - e. Consult with a local soil engineer or building department official to verify all soil values.
- 2.
- a. $f_y = 40,000$ psi for #4; $f_y = 60,000$ psi for #5 or larger
 - b. Consult with local building officials to verify conformance with minimum and maximum steel requirements.

TABLE "A"
70 PCF ACTIVE SOIL PRESSURE

H	B	C	D	E	X BARS
3'	2'-4"	6"	1'-0"	1'-0"	#4 @ 20"
4'	3'-3"	1'-0"	1'-6"	1'-3"	#4 @ 20"
5'	4'-1"	1'-0"	2'-2"	1'-6"	#5 @ 20"
6'	4'-11"	1'-0"	2'-10"	2'-3"	#5 @ 10"

- Note: 1. Design is also based upon:
- a. Soil bearing capacity of 1000 PSF
 - b. Soil weight of 120 PCF
 - c. Passive pressure of 250 PSF
 - d. Coefficient of friction = 0.35
 - e. Consult with a local soil engineer or building department official to verify all soil values.
2. a. $f_y = 40,000$ psi for #4; $f_y = 60,000$ psi for #5 or larger
- b. Consult with local building officials to verify conformance with minimum and maximum steel requirements.

TABLE "A"
75 PCF ACTIVE SOIL PRESSURE

H	B	C	D	E	X BARS
3'	2'-5"	6"	1'-1"	1'-0"	#4 @ 20"
4'	3'-4"	1'-0"	1'-8"	1'-6"	#4 @ 20"
5'	4'-3"	1'-0"	2'-4"	1'-6"	#5 @ 20"
6'	5'-1"	1'-0"	2'-11"	2'-6"	#5 @ 10"

- Note: 1. Design is also based upon:
- a. Soil bearing capacity of 1000 PSF
 - b. Soil weight of 120 PCF
 - c. Passive pressure of 250 PSF
 - d. Coefficient of friction = 0.35
 - e. Consult with a local soil engineer or building department official to verify all soil values.
2. a. $f_y = 40,000$ psi for #4; $f_y = 60,000$ psi for #5 or larger
- b. Consult with local building officials to verify conformance with minimum and maximum steel requirements.

TABLE "B"
8 FOOT RETAINING WALL

ACTIVE SOIL PRESSURE	H	B	C	D	COURSES OF VWF 8	E	X BARS
30	8'	4'-6"	1'-0"	1'-10"	-	2'-0"	#5 @ 10"
35	8'	4'-11"	1'-0"	2'-2"	-	2'-0"	#5 @ 10"
40	8'	5'-4"	1'-0"	2'-6"	-	2'-0"	#5 @ 10"
45	8'	5'-6"	1'-0"	2'-10"	-	3'-0"	#5 @ 10"
50	8'	5'-10"	1'-0"	3'-1"	-	3'-0"	#6 @ 10"
55	8'	6'-2"	1'-0"	3'-4"	1	3'-0"	#6 @ 10"
60	8'	6'-7"	1'-0"	3'-8"	1	3'-0"	#6 @ 10"
65	8'	6'-10"	1'-0"	3'-10"	1	3'-6"	#6 @ 10"
70	8'	7'-0"	1'-6"	3'-11"	1	3'-6"	#6 @ 10"
75	8'	7'-2"	1'-6"	4'-2"	2	3'-6"	#6 @ 10"

- Note: 1. Design is also based upon:
- a. Soil bearing capacity of 1000 PSF
 - b. Soil weight of 120 PCF
 - c. Passive pressure of 250 PSF
 - d. Coefficient of friction = 0.35
 - e. Consult with a local soil engineer or building department official to verify all soil values.
- 2.
- a. $f_y = 40,000$ psi for #4; $f_y = 60,000$ psi for #5 or larger
 - b. Consult with local building officials to verify conformance with minimum and maximum steel requirements.

TABLE "C"
10 FOOT RETAINING WALL

ACTIVE SOIL PRESSURE	H	B	C	D	E	COURSES OF VWF8	X BARS	Y BARS
40	10'	6'-0"	1'-6"	3'-4"	3'-0"	3	#7 @ 10"	-
45	10'	6'-6"	1'-6"	3'-8"	3'-6"	3	#7 @ 10"	-
50	10'	7'-0"	1'-6"	4'-1"	4'-0"	3	#6 @ 10"	#7 @ 9"
55	10'	7'-0"	1'-6"	4'-4"	4'-0"	3	#6 @ 10"	#7 @ 8"

- Note: 1. Design is also based upon:
- a. Soil bearing capacity of 1000 PSF
 - b. Soil weight of 120 PCF
 - c. Passive pressure of 250 PSF
 - d. Coefficient of friction = 0.35
 - e. Consult with a local soil engineer or building department official to verify all soil values.
- 2.
- a. $f_y = 40,000$ psi for #4; $f_y = 60,000$ psi for #5 or larger
 - b. Consult with local building officials to verify conformance with minimum and maximum steel requirements.

TABLE "D"
STEM WALL FOUNDATIONS - WOOD FRAME WALLS

STORIES	A (MIN.)	B (MIN.)	C (MIN.)
ONE	1' - 0"	6"	1' - 0"
TWO	1' - 3"	7"	1' - 6"

TABLE "E"
FULL HEIGHT SMARTBLOCK WALLS

STORIES	A (MIN.)	B (MIN.)	C (MIN.)
ONE	1' - 9"	9"	1' - 0"
TWO	3' - 0"	1' - 3"	1' - 6"

9.2 Detail Section

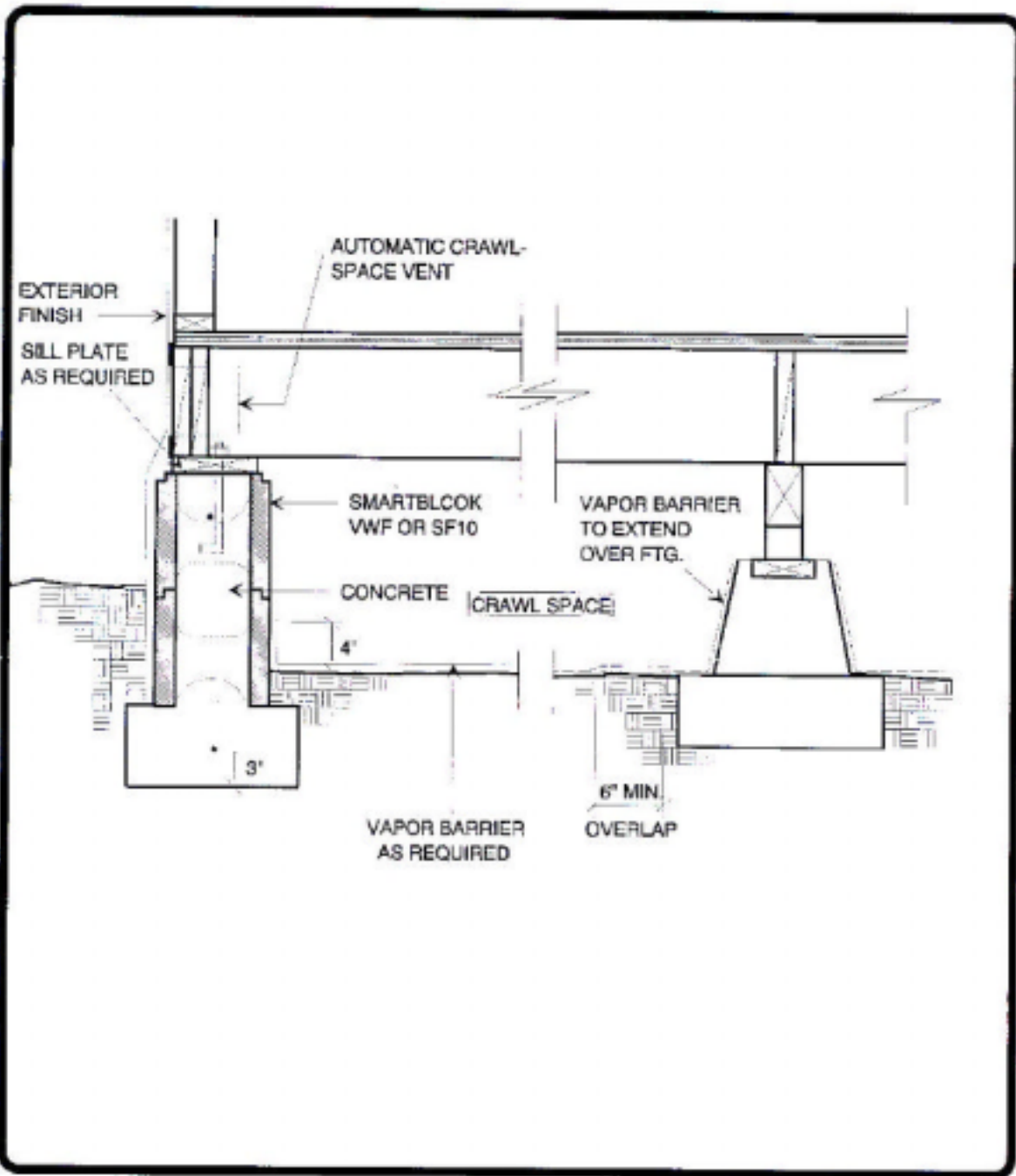

	<p style="text-align: center;">CONFORM</p> <p style="text-align: center;">CONTROLLED VENTILATED CRAWL SPACE DETAIL</p>	<p style="text-align: center;">DETAIL 1.0</p>
--	--	--

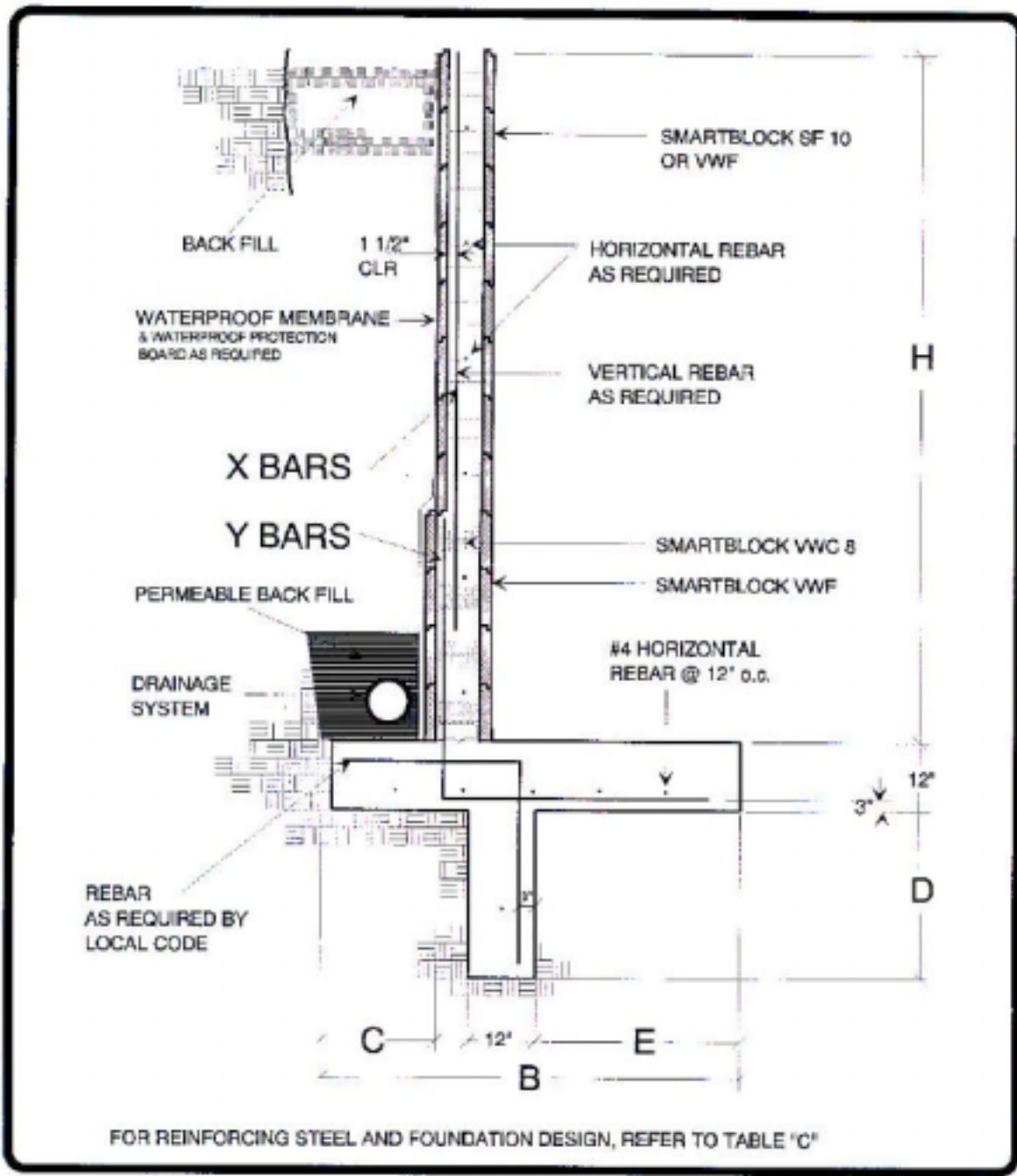

	CONFORM	RETAINING WALL DETAIL	DETAIL 2.0

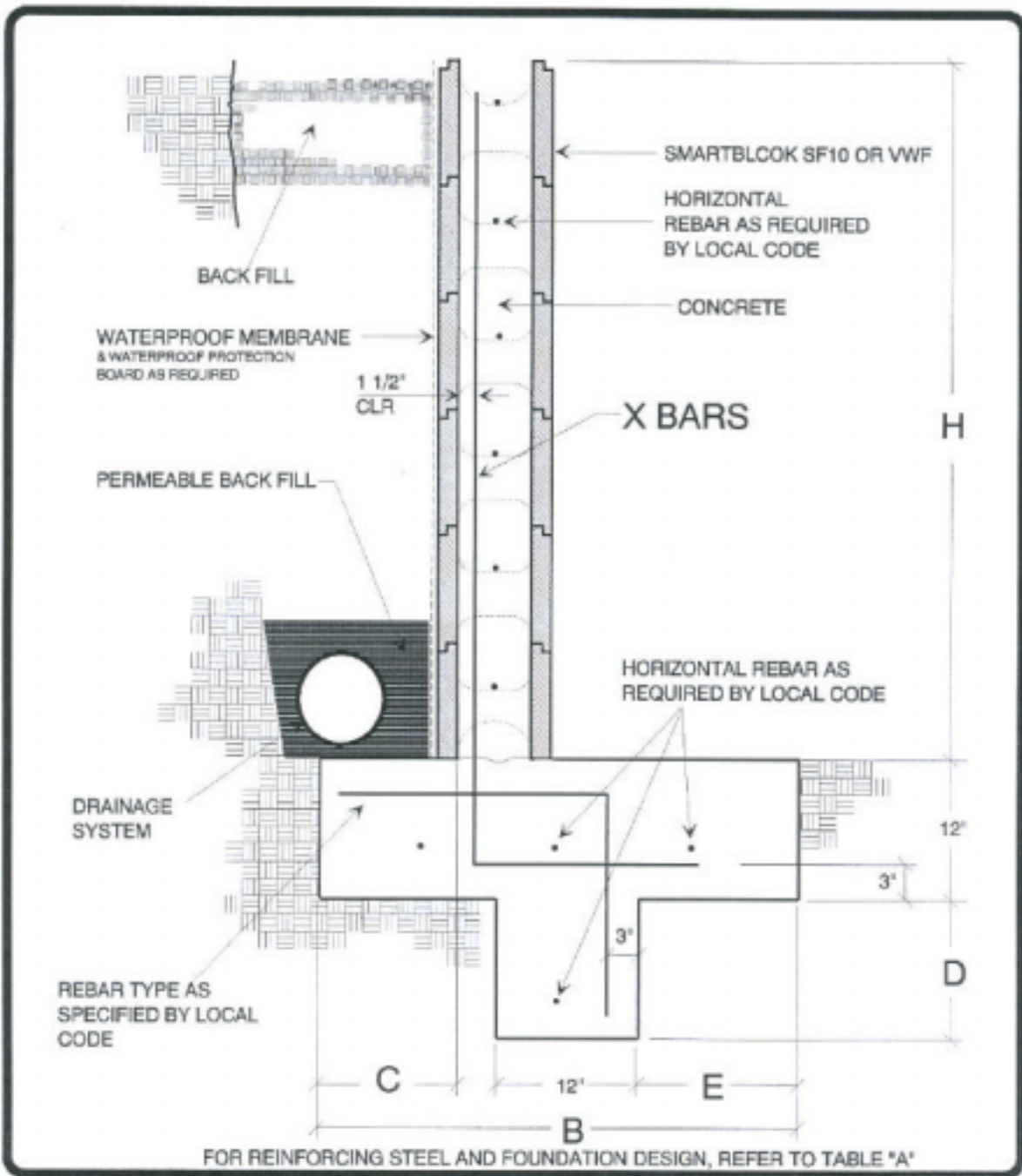

	CONFORM	RETAINING WALL DETAIL DETAIL 3.0

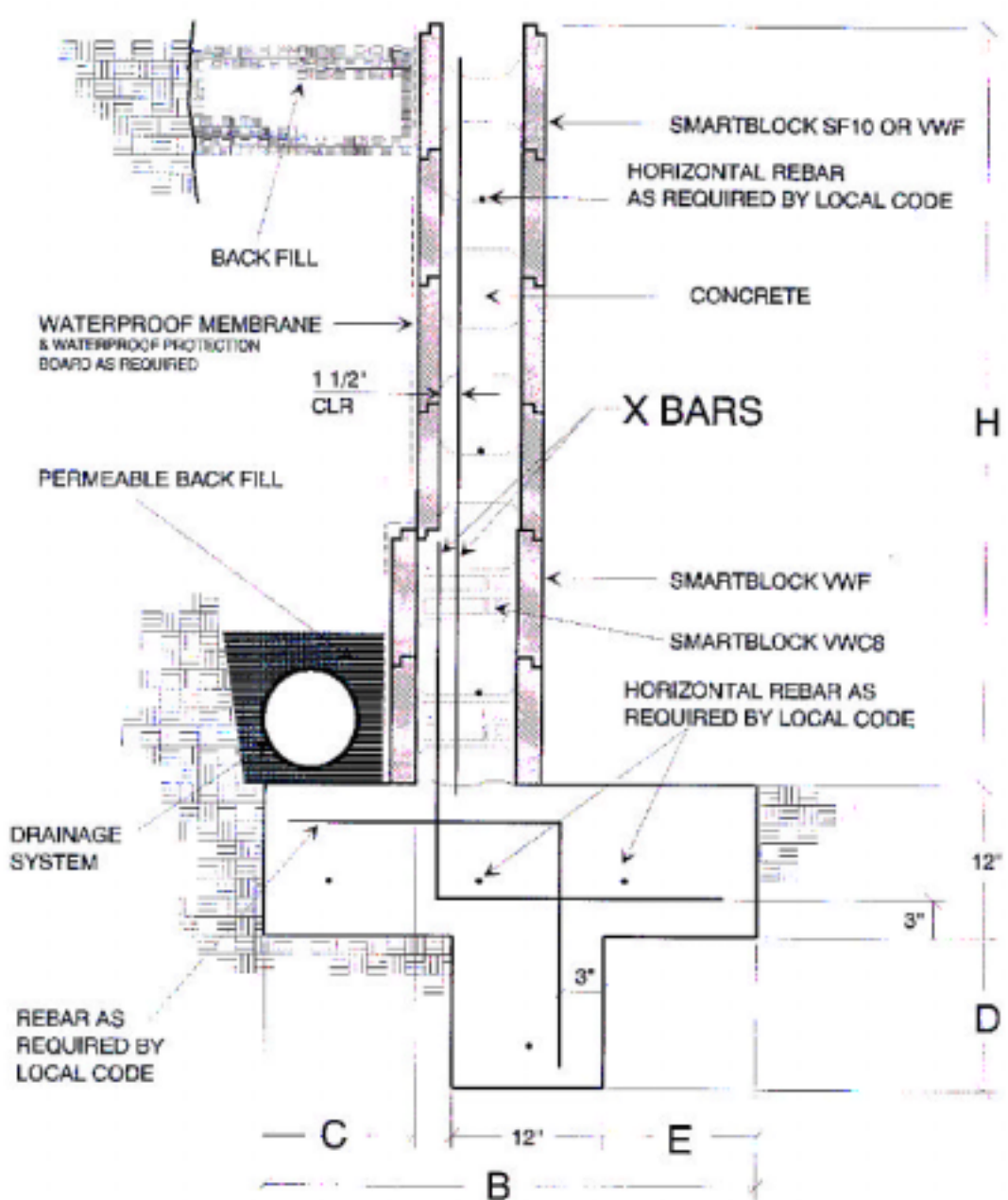

FOR REINFORCING STEEL AND FOUNDATION DESIGN, REFER TO TABLE "B"

	CONFORM	RETAINING WALL DETAIL DETAIL 4.0

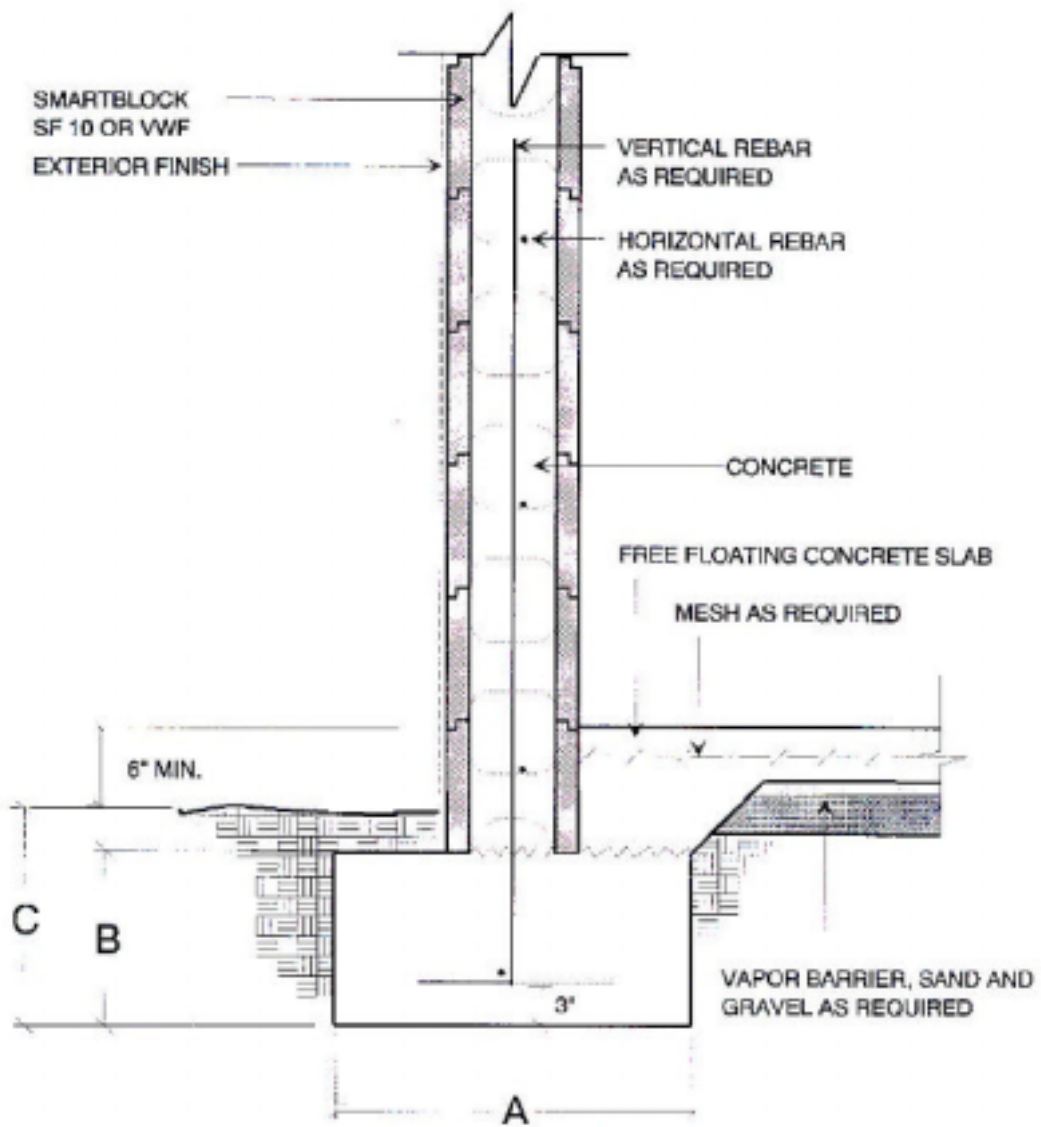

FOR REINFORCING STEEL AND FOUNDATION DESIGN, REFER TO TABLE "E"

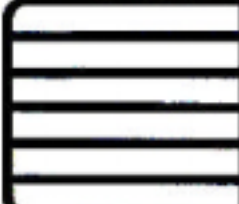

CONFORM

FOUNDATION DETAIL

2 POUR SMARTBLOCK INSULATED
BUILDING WALL AND SLAB

DETAIL

5.0

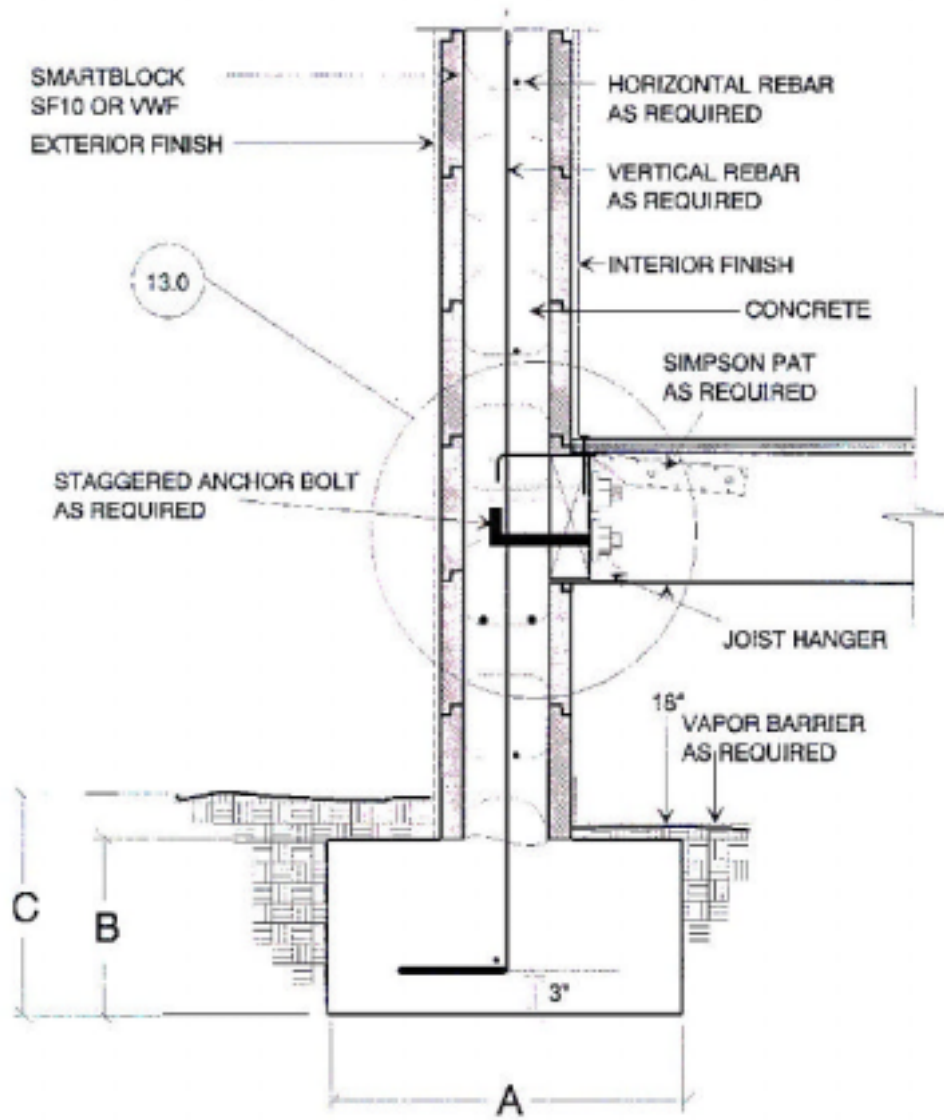

FOR REINFORCING STEEL AND FOUNDATION DESIGN, REFER TO TABLE "E"



CONFORM

FOUNDATION DETAIL

2 POUR SMARTBLOCK INSULATED BUILDING WALL AND SLAB

DETAIL

6.0

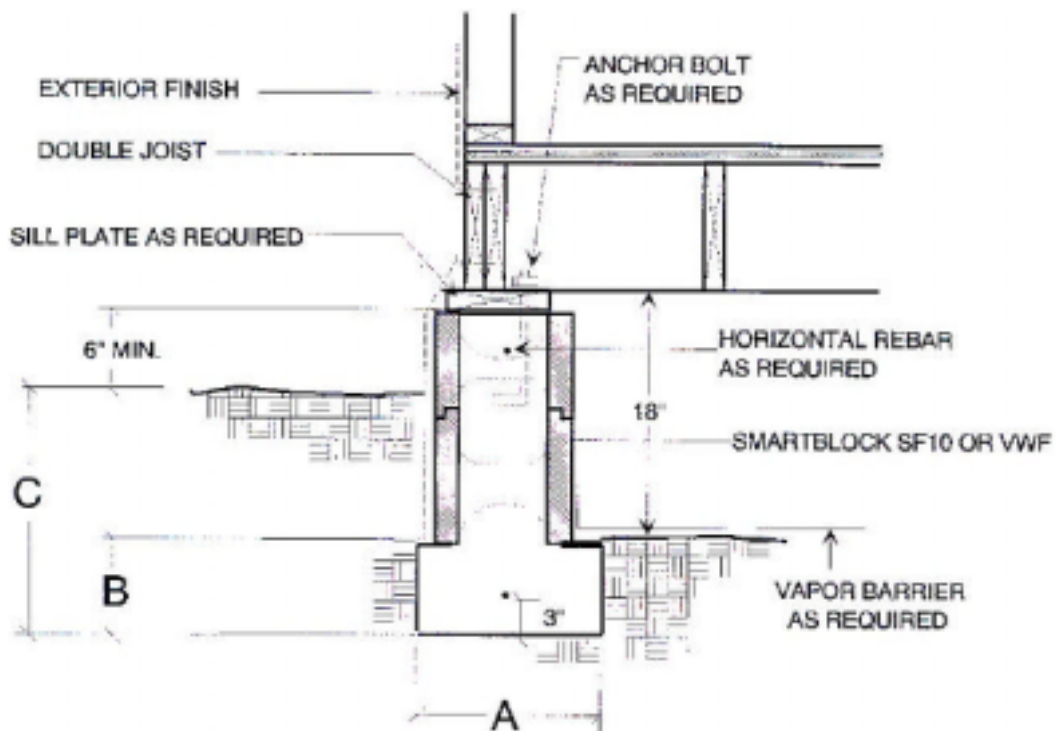

FOR REINFORCING STEEL AND FOUNDATION DESIGN, REFER TO TABLE "D"



CONFORM

FOUNDATION DETAIL

JOIST RUNNING PARALLEL

DETAIL

7.0

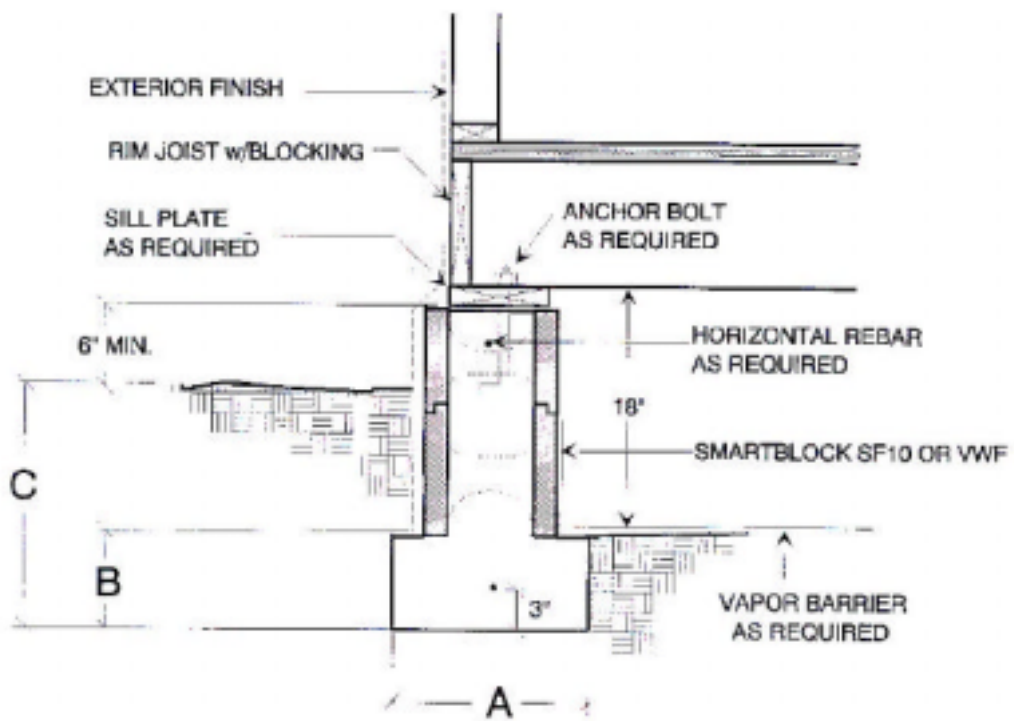

FOR REINFORCING STEEL AND FOUNDATION SIZE, REFER TO TABLE "D"

CONFORM

FOUNDATION DETAIL
JOIST RUNNING PERPENDICULAR

DETAIL
8.0

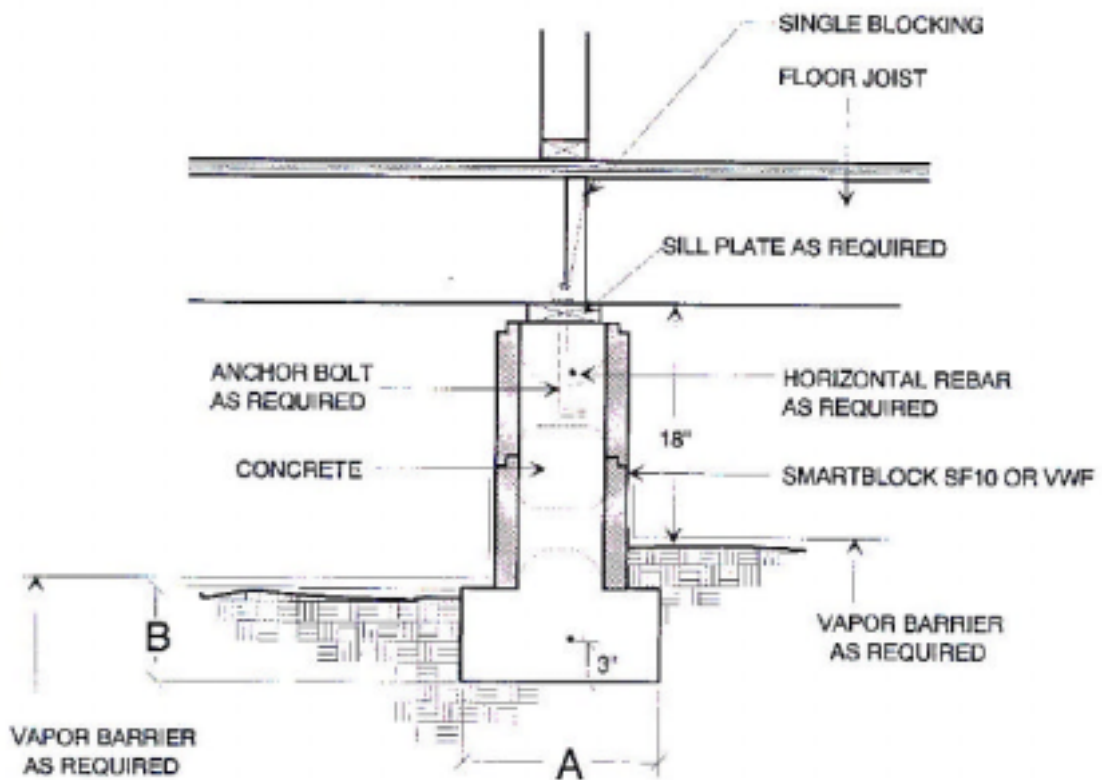

FOR REINFORCING STEEL AND FOUNDATION DESIGN, REFER TO TABLE "D"

CONFORM

FOUNDATION DETAIL
INTERIOR BEARING FOUNDATION
JOIST RUNNING PERPENDICULAR

DETAIL
9.0

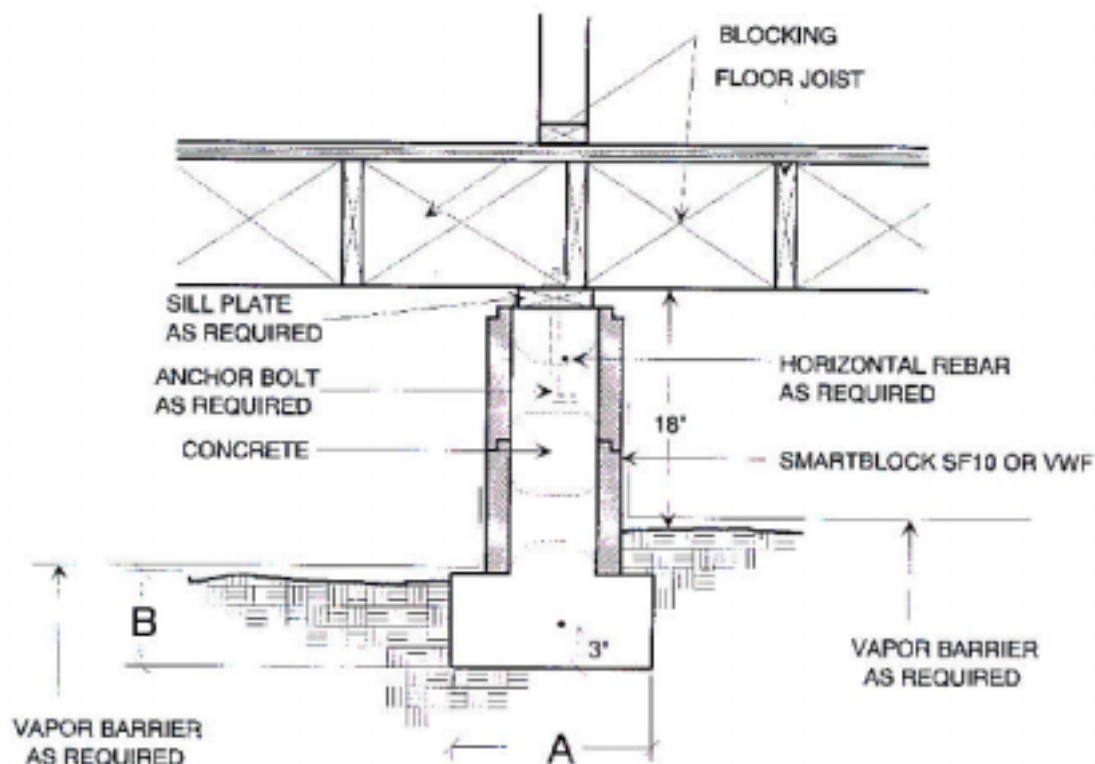

FOR REINFORCING STEEL AND FOUNDATION DESIGN, REFER TO TABLE 'D'

	<p style="text-align: center;">CONFORM</p> <p style="text-align: center;">FOUNDATION DETAIL</p> <hr/> <p style="text-align: center;">INTERIOR BEARING FOUNDATION</p> <p style="text-align: center;">JOIST RUNNING PARALLEL</p>	<p style="text-align: center;">DETAIL</p> <p style="text-align: center;">10.0</p>
--	--	---

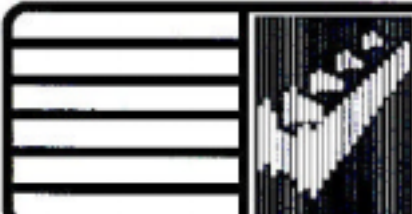
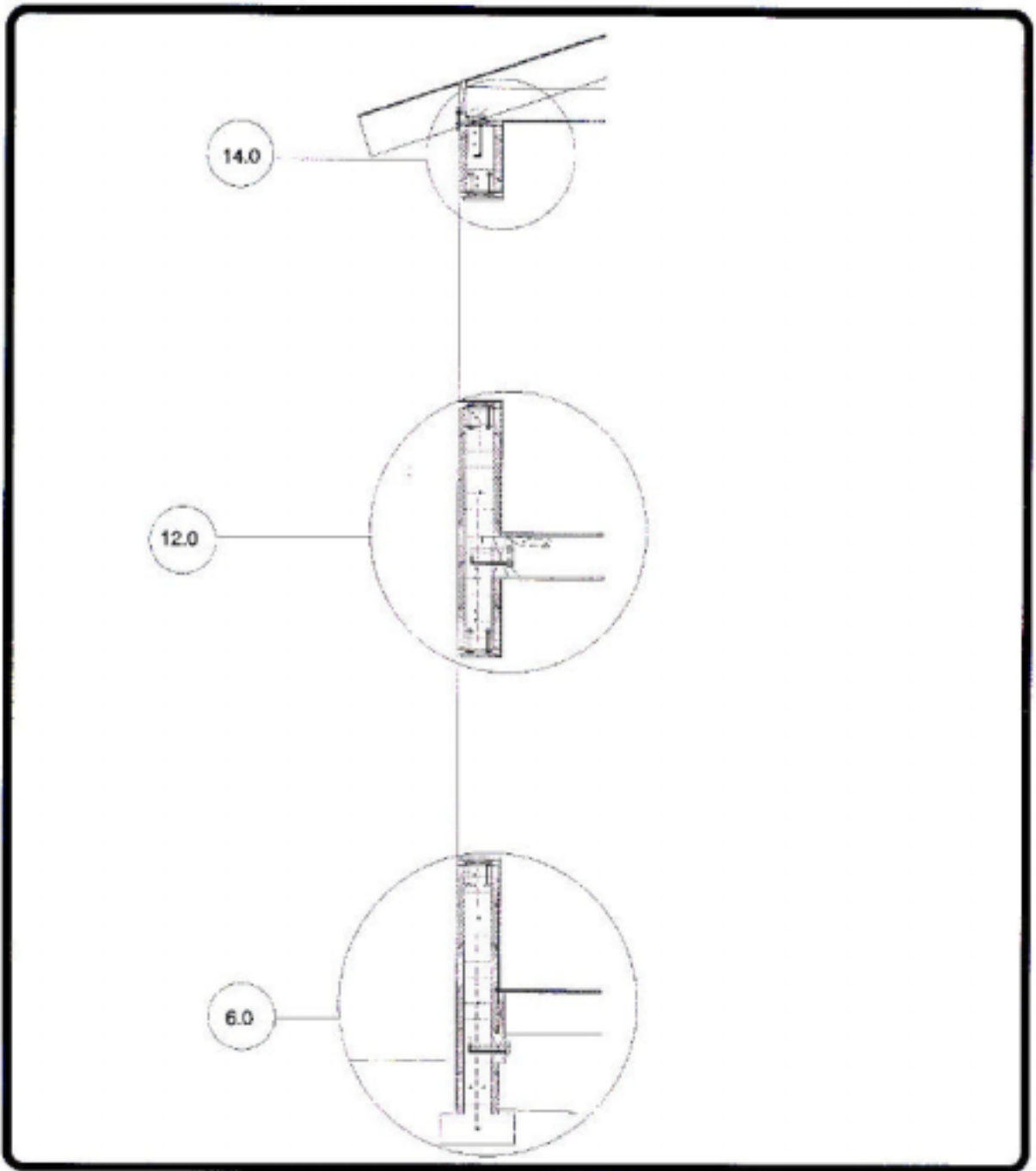

CONFORM

**FULL HEIGHT WALL SECTION
TWO STORY**

**DETAIL
11.0**

13.0

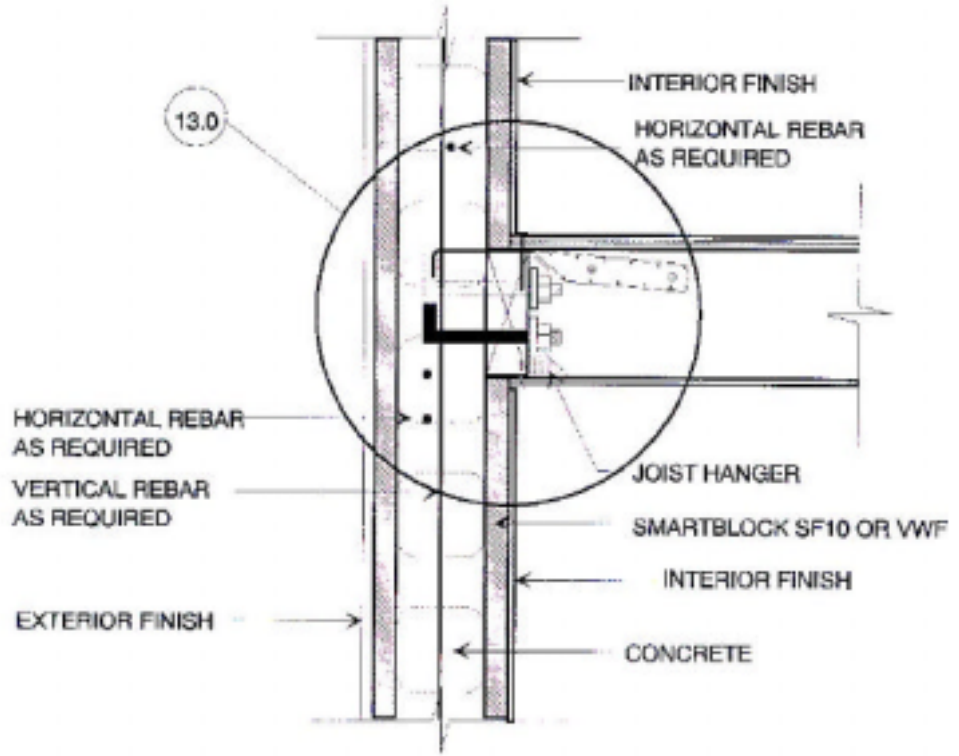

CONFORM

**LEDGER DETAIL
FLUSH MOUNTED**

**DETAIL
12.0**

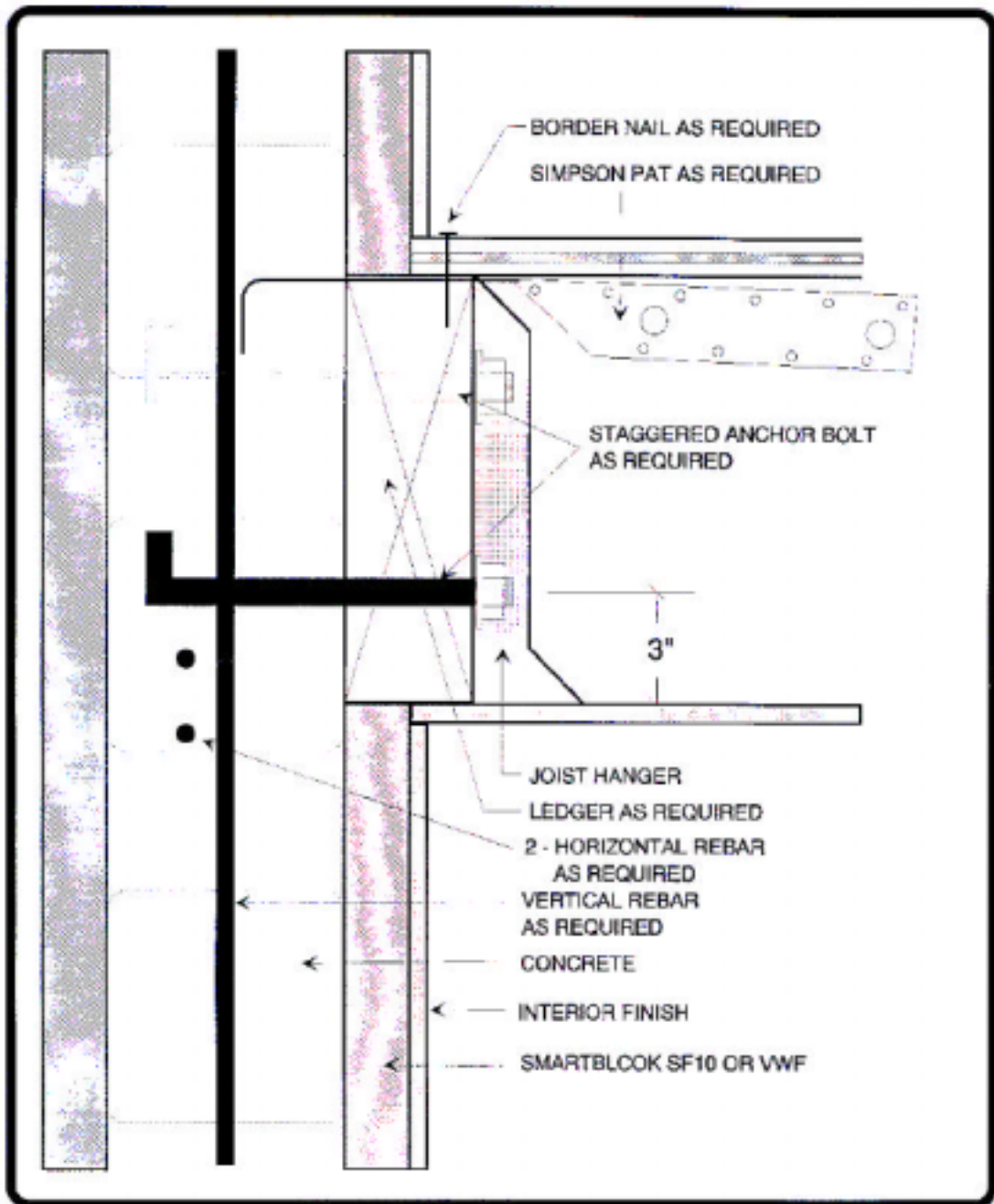

	CONFORM	DETAIL 13.0
	LEDGER DETAIL FLUSH MOUNTED	

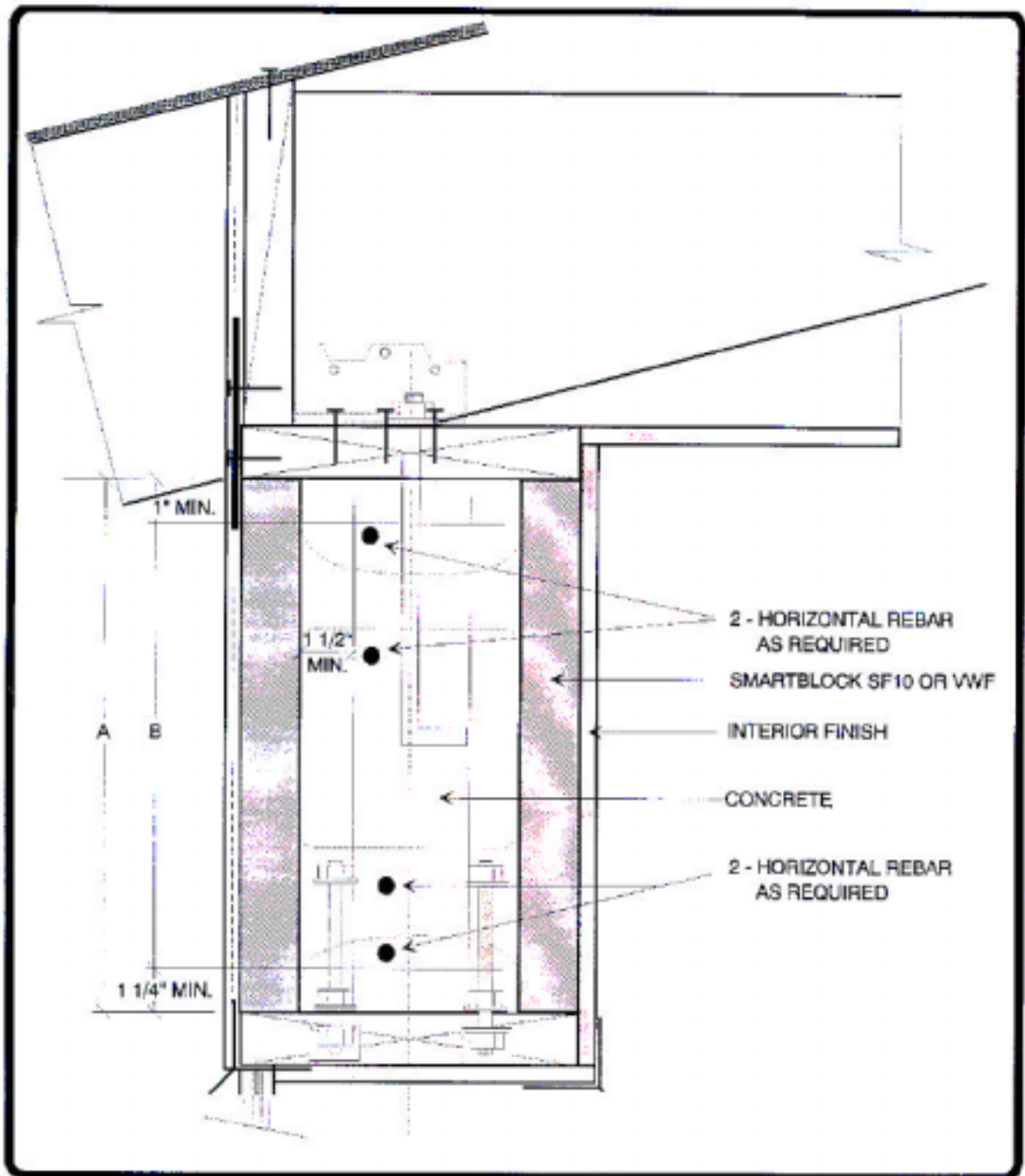

CONFORM

**LINTEL DETAIL
AT EAVE**

**DETAIL
14.0**

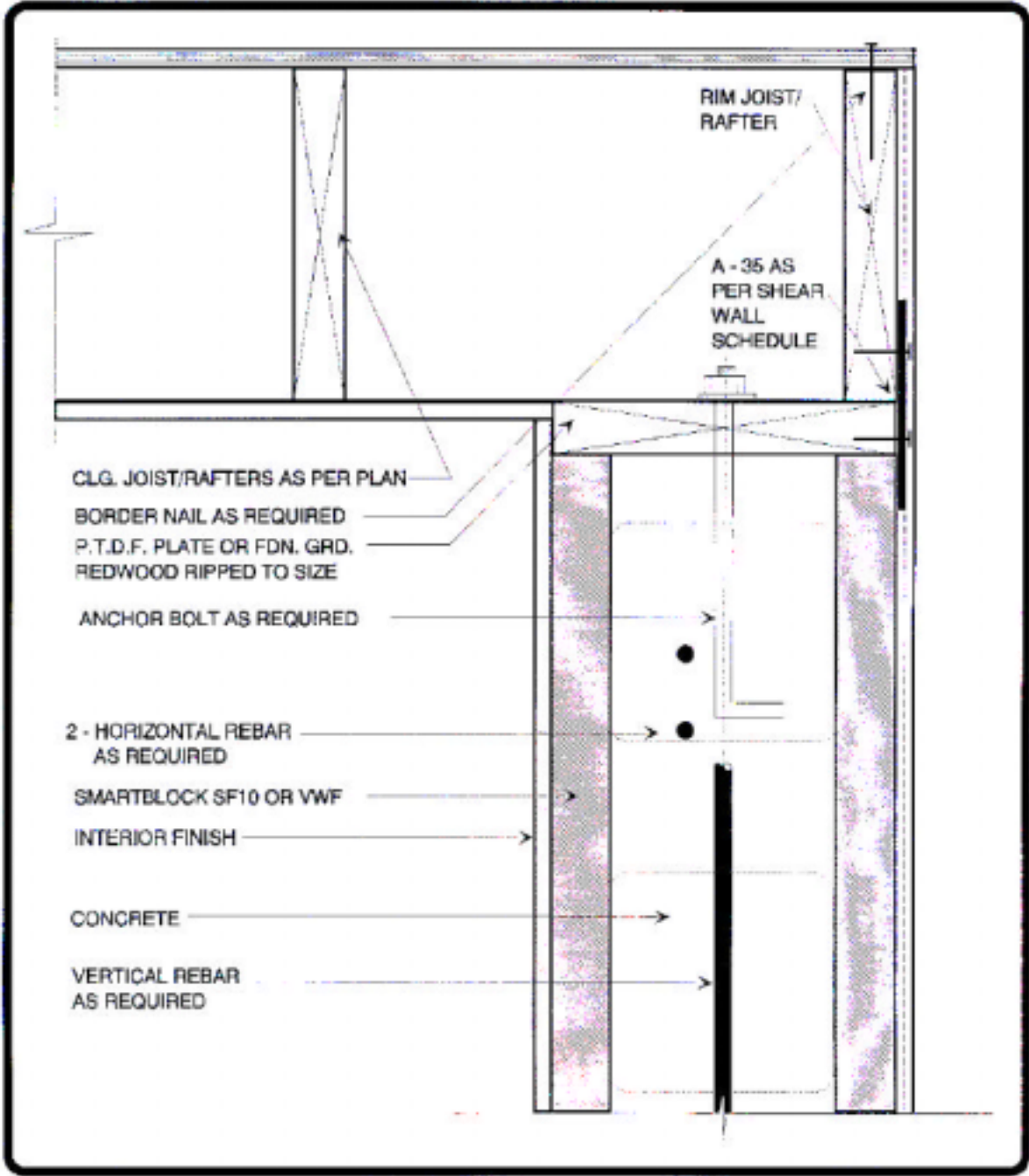

	<p style="text-align: center;">CONFORM</p> <p>EAVE DETAIL RAFTER RUNNING PARALLEL</p>	<p style="text-align: center;">DETAIL 15.0</p>
--	--	--

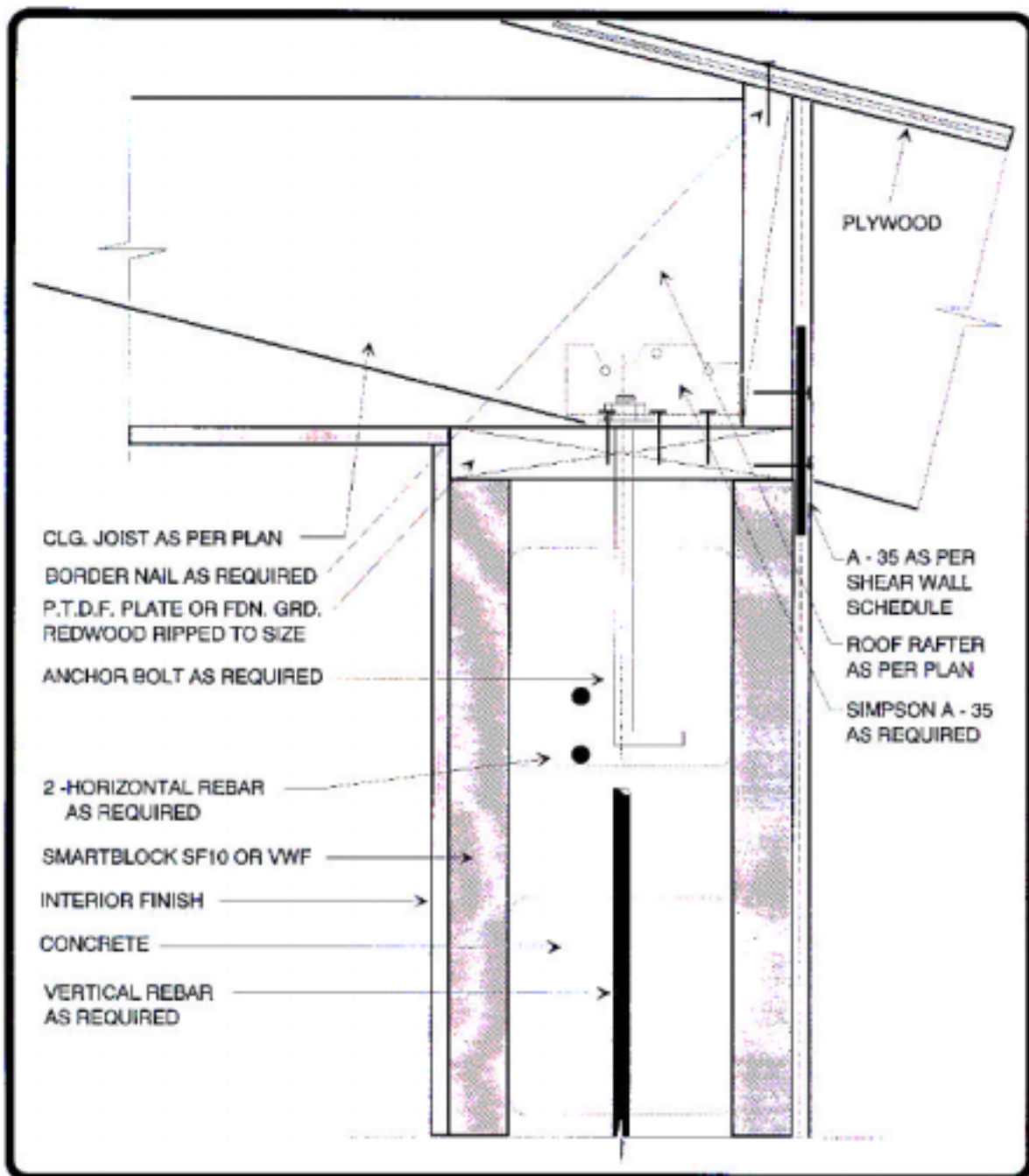

		<p>CONFORM</p> <p>EAVE DETAIL</p> <p>RAFTER RUNNING PERPENDICULAR</p>	<p>DETAIL</p> <p>16.0</p>
--	--	--	---

2" WIDE, 20 GA. - METAL SMARTTACH
OR

1 1/2" WIDE, 24 GA. - METAL STRIP 2" BELOW CEILING LINE

16d BOX NAILS @ 10" O.C. INSERTED
THROUGH METAL STRIP AND FOAM,
SECURED AT FOAM w/ SPEED WASHER
BEFORE PLACEMENT OF CONCRETE

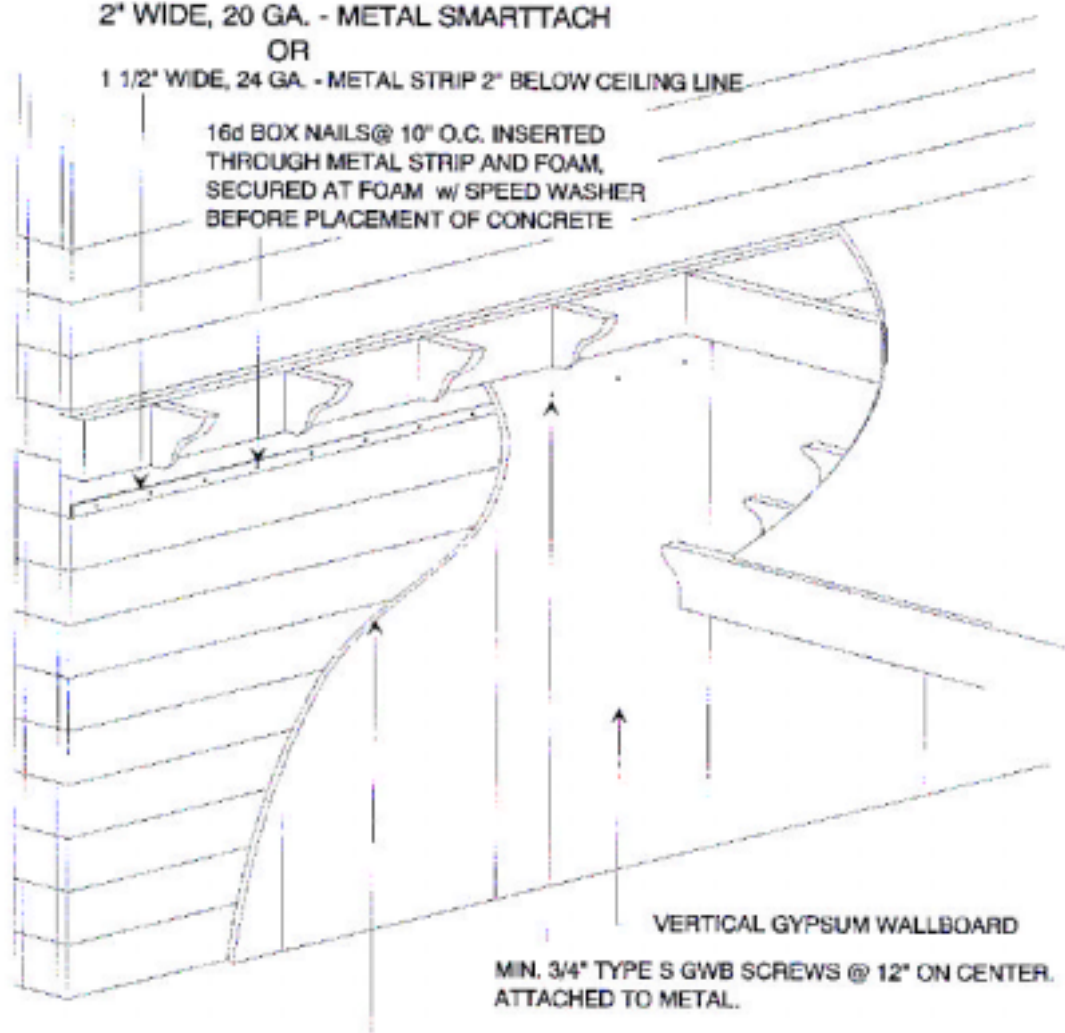

SECURE WITH APPROVED DRYWALL
ADHESIVE AS PER SPECS.



CONFORM
GYP. BOARD
ATTACHMENT DETAIL
HORIZ. METAL STRIP METHOD

DETAIL
17.0

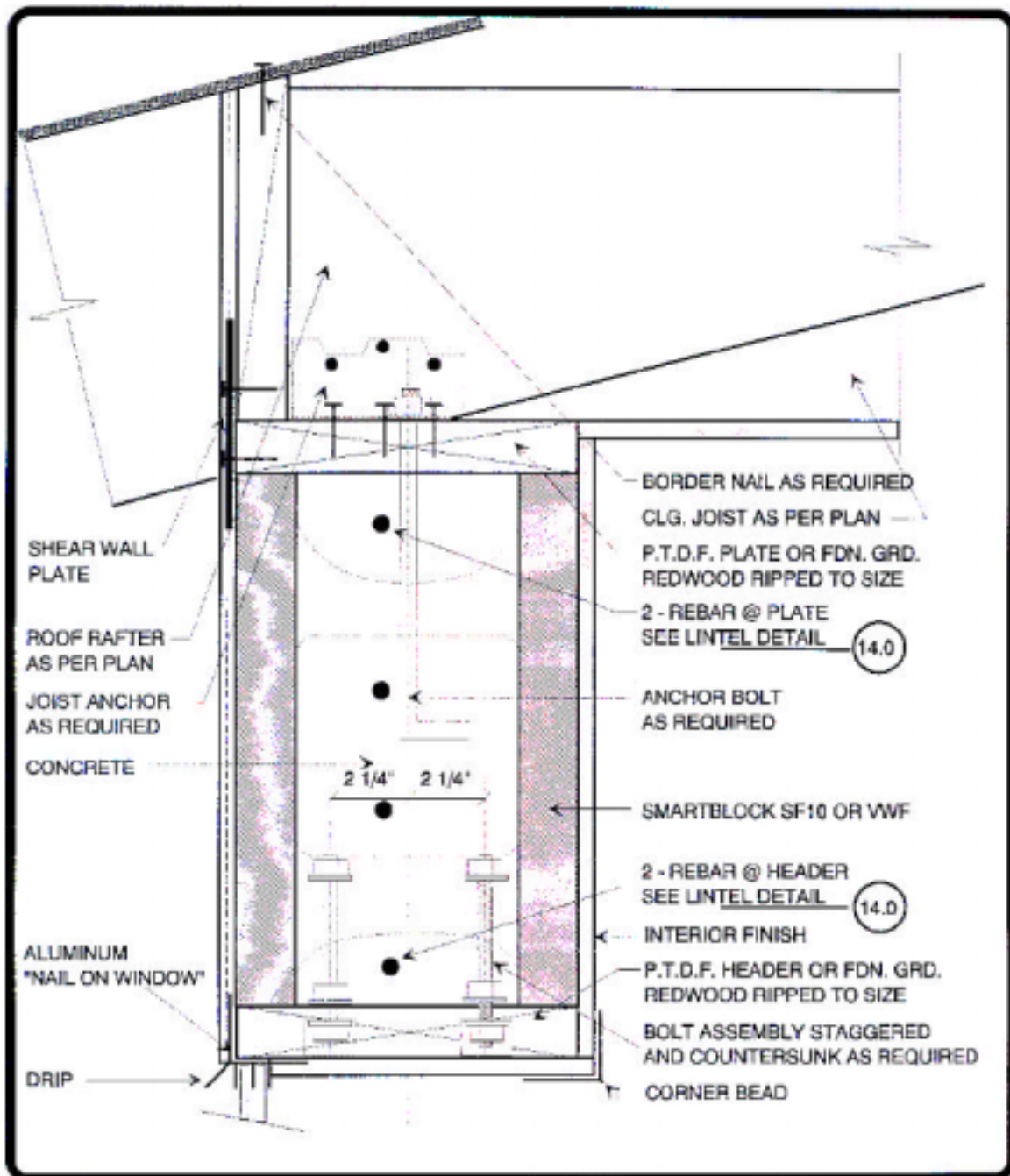

CONFORM

**WINDOW DETAIL
HEAD**

**DETAIL
18.0**

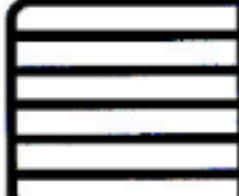
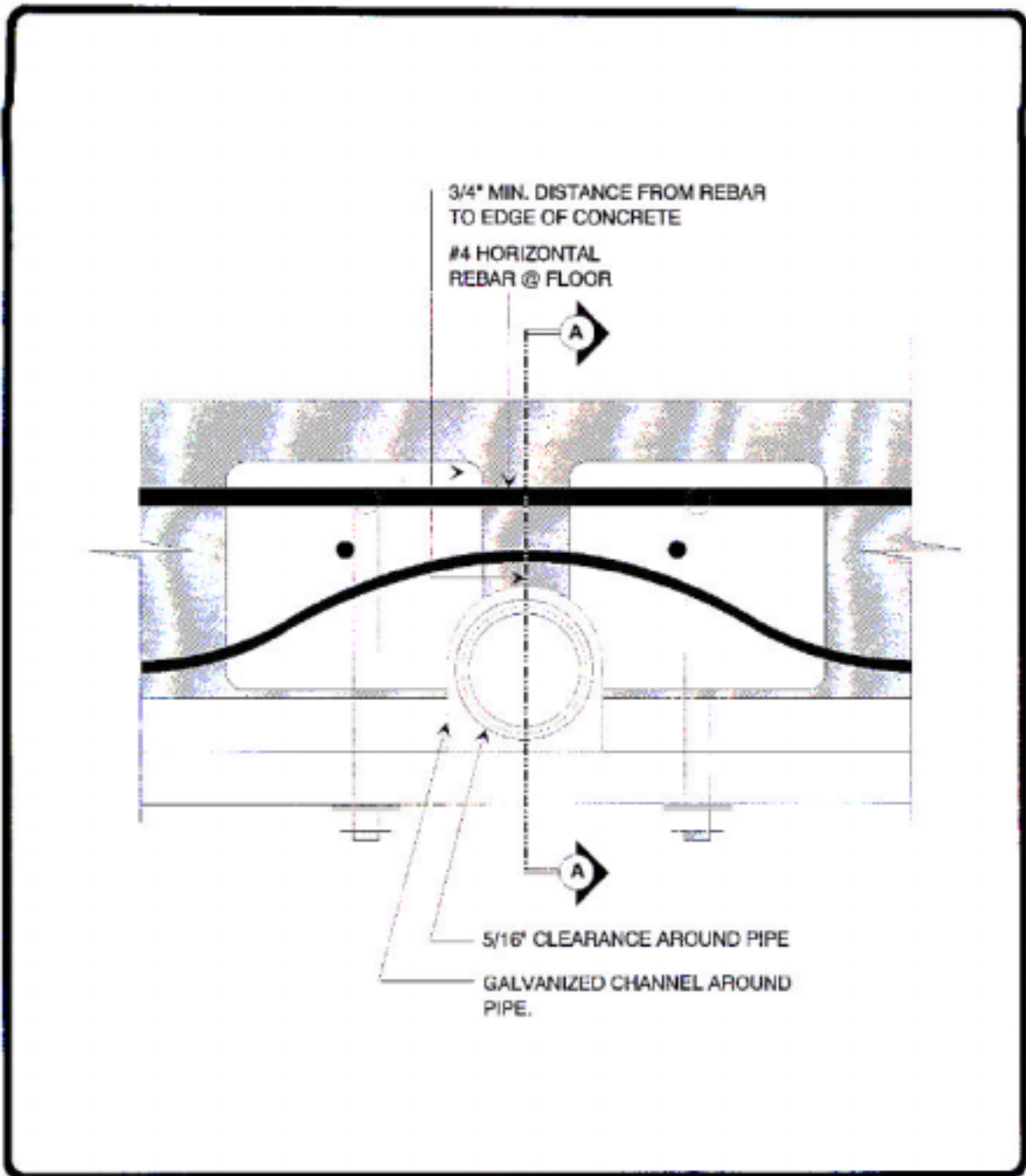

CONFORM

CHASE DETAIL
3" VERTICAL DROP AT LEDGER

DETAIL
19.0

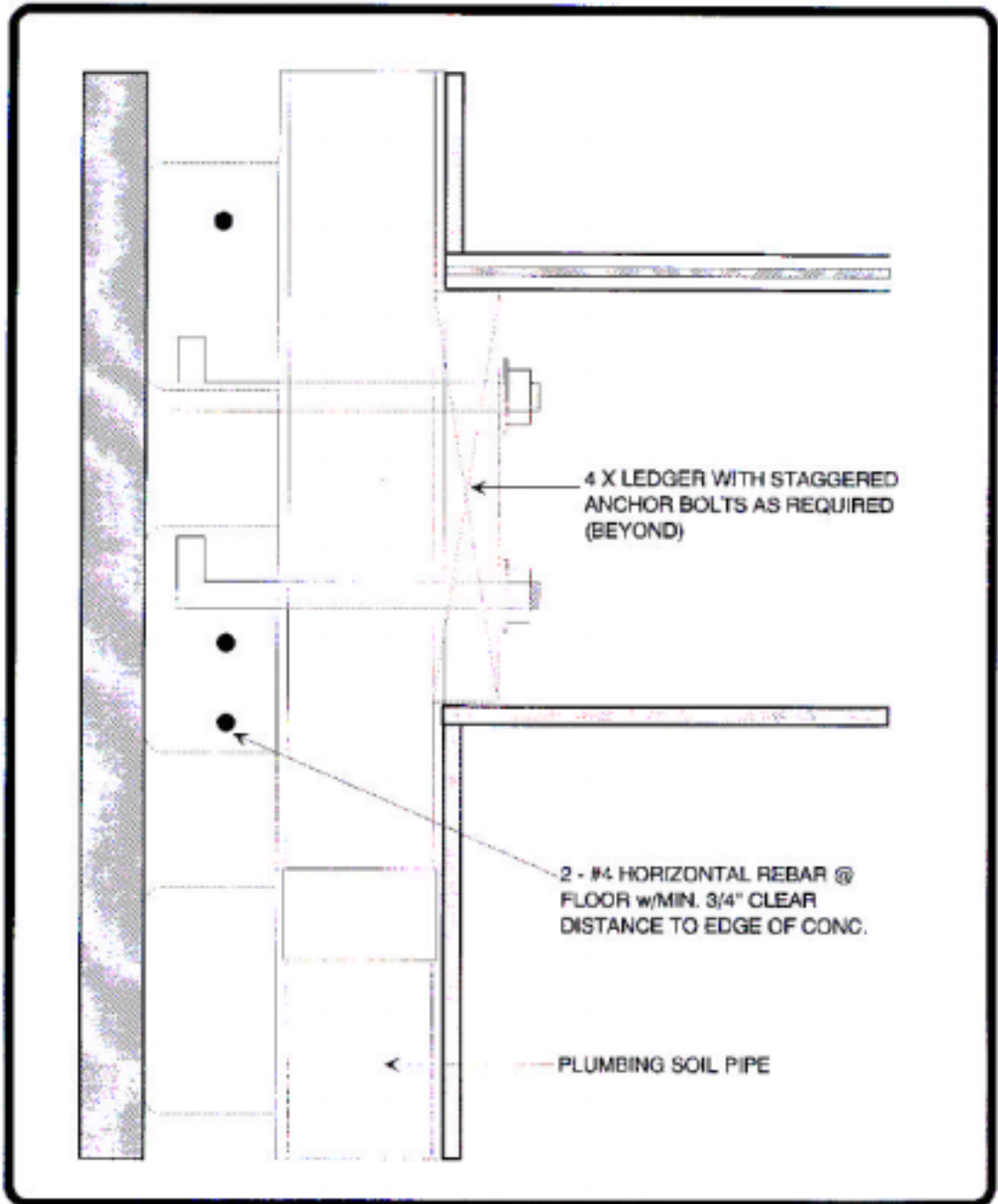

	CONFORM	DETAIL 19.0A
	SECTION "A-A"	
	PLUMBING CHASE DETAIL	

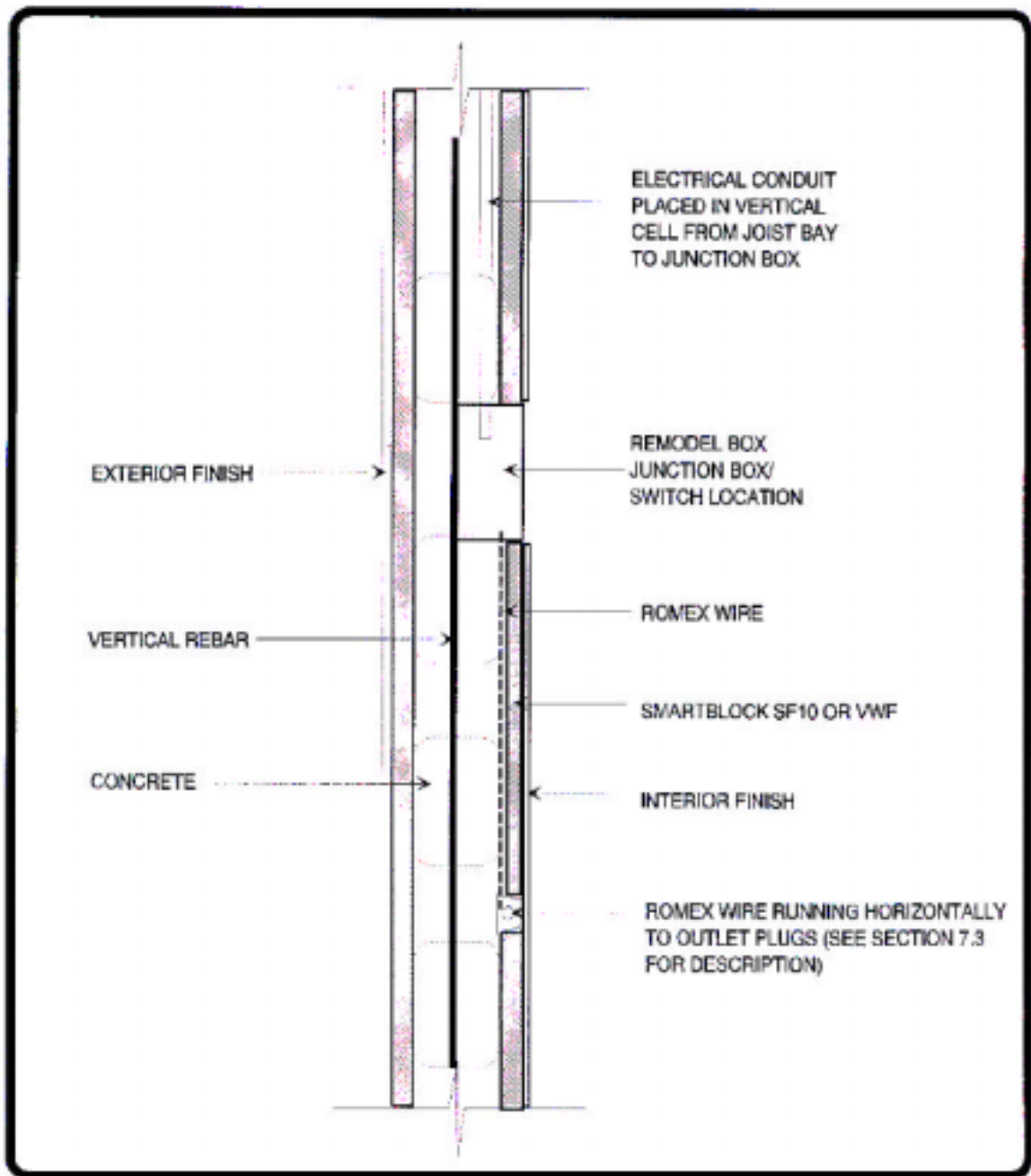

	<p style="text-align: center;">CONFORM</p> <hr/> <p style="text-align: center;">ELECTRICAL PLACEMENT</p>	<p style="text-align: center;">DETAIL 20.0</p>
--	--	---

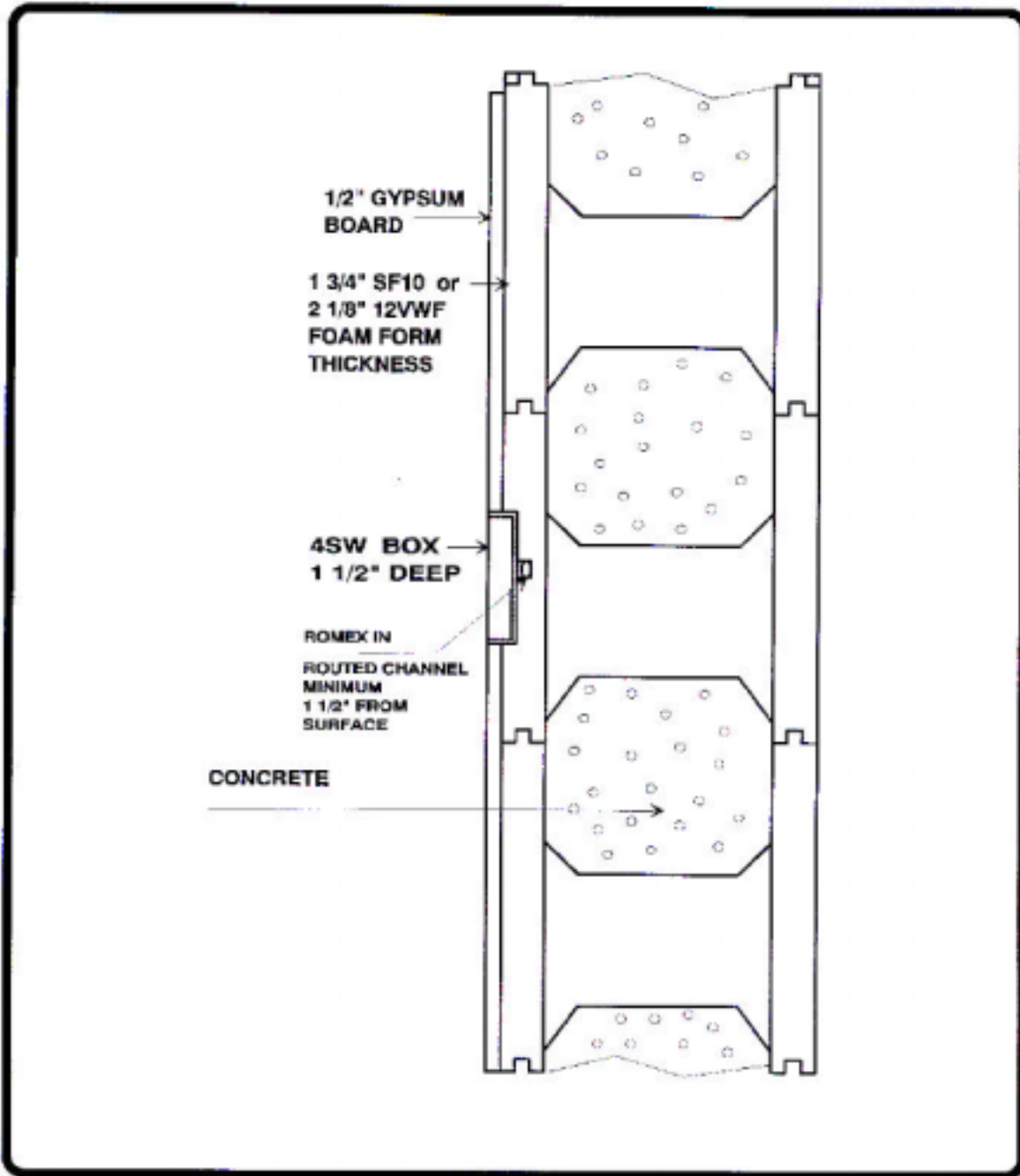

	<p>CONFORM</p> <p>ELECTRICAL PLACEMENT</p> <hr/> <p>ALTERNATIVE VIEW</p>	<p>DETAIL</p> <p>21.0</p>
--	---	---------------------------

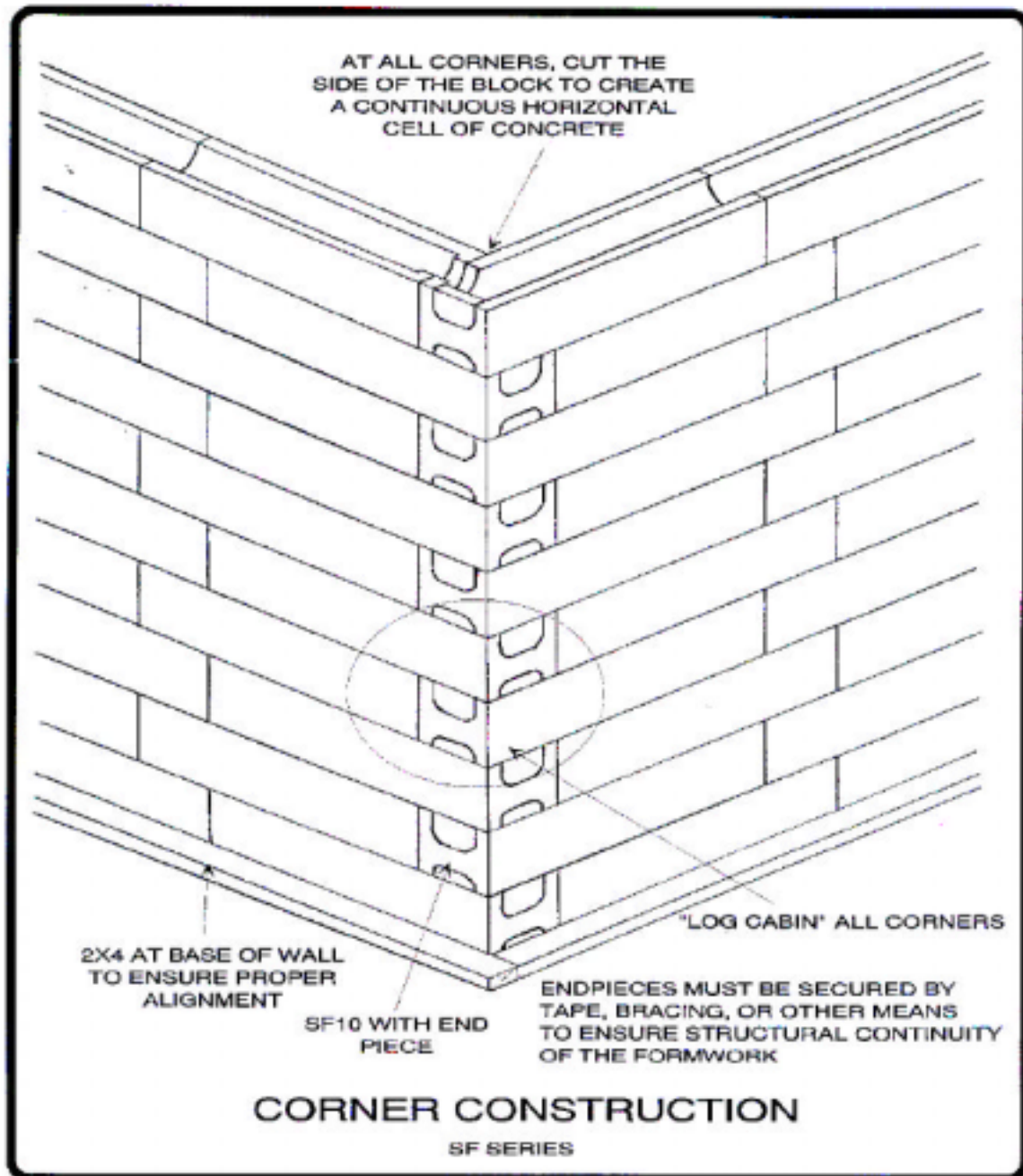

	<p>CONFORM</p> <p>CORNER CONSTRUCTION</p>	<p>DETAIL 22.0</p>
--	---	--------------------------------------

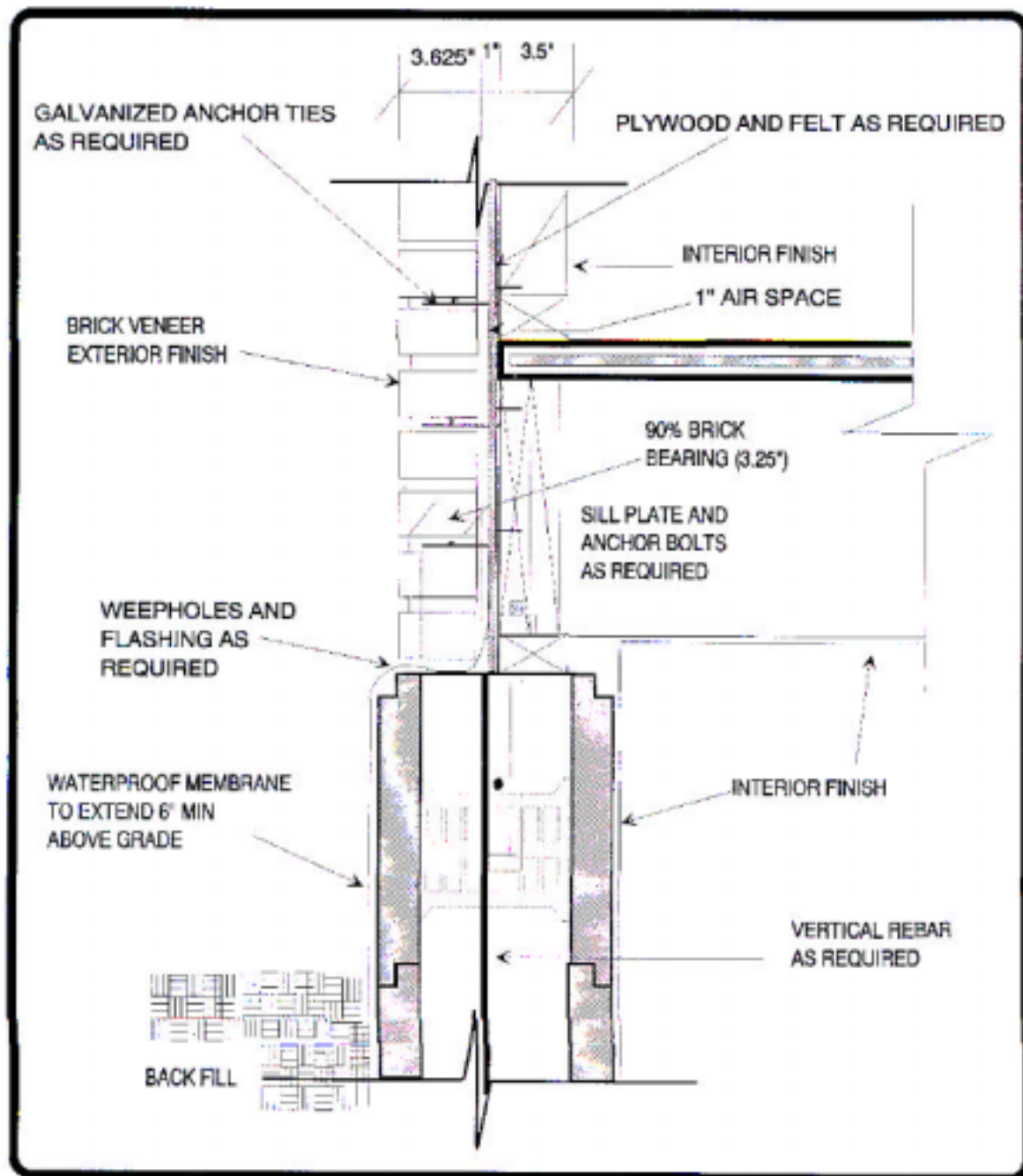

	CONFORM	DETAIL 23.0
	4" BRICK VENEER 2x4 STUD WALLS	

9.3 Micellaneous Details

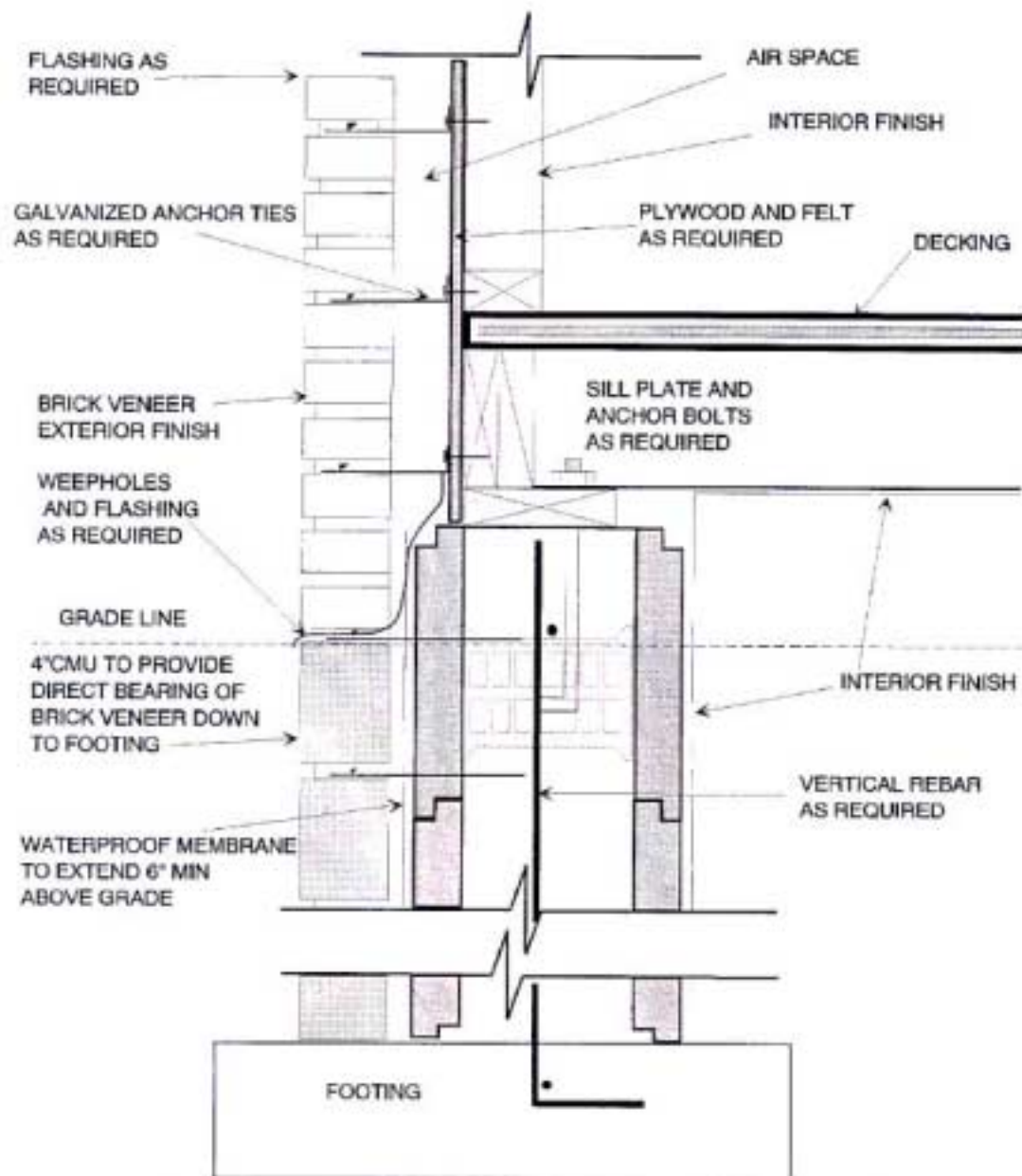

PROPOSED DETAIL
4" BRICK LEDGE (WITH CMU'S)

American ConForm Industries' proposed details are for conceptual purposes only. It is the responsibility of the designer, purchaser or installer to confirm the adequacy of American ConForm Industries' proposed details for compliance with the relevant city, county, state or federal building and design codes.

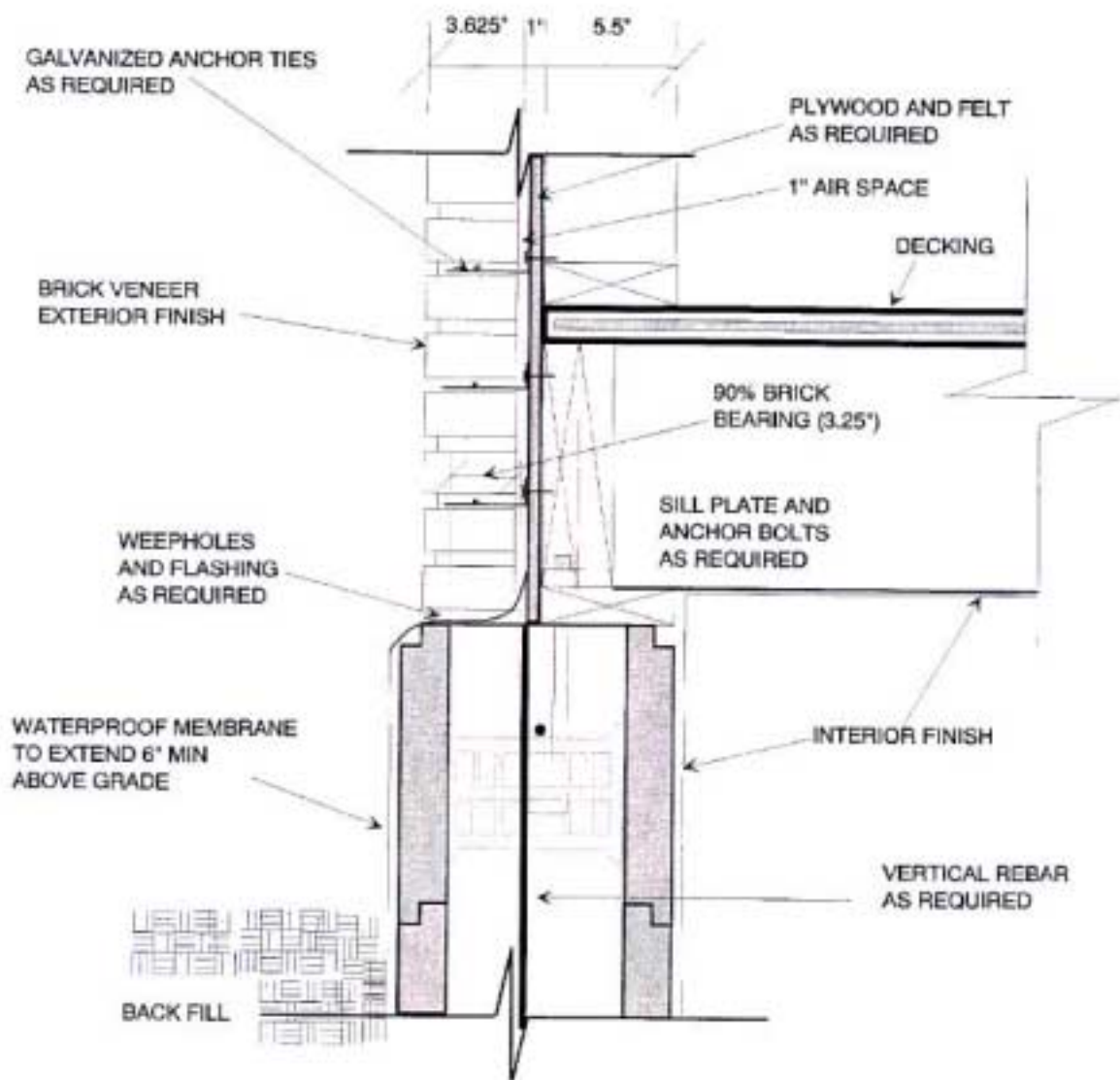

PROPOSED DETAIL

4" BRICK VENEER FOR 2x6 STUD WALLS

American ConForm Industries' proposed details are for conceptual purposes only. It is the responsibility of the designer, purchaser or installer to confirm the adequacy of American ConForm Industries' proposed details for compliance with the relevant city, county, state or federal building and design codes.

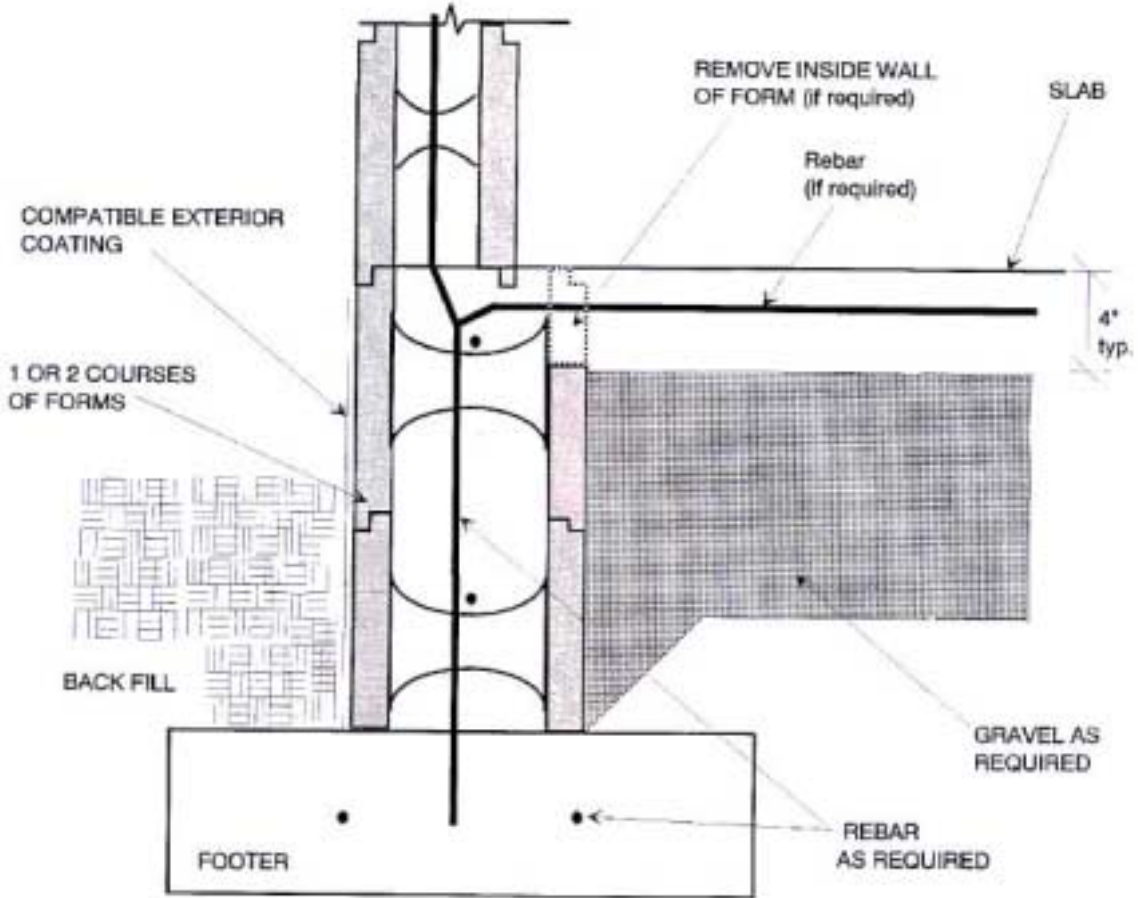

PROPOSED DETAIL

INSULATED SLAB EDGE (VWF SERIES)

American ConForm Industries' proposed details are for conceptual purposes only. It is the responsibility of the designer, purchaser or installer to confirm the adequacy of American ConForm Industries' proposed details for compliance with the relevant city, county, state or federal building and design codes.

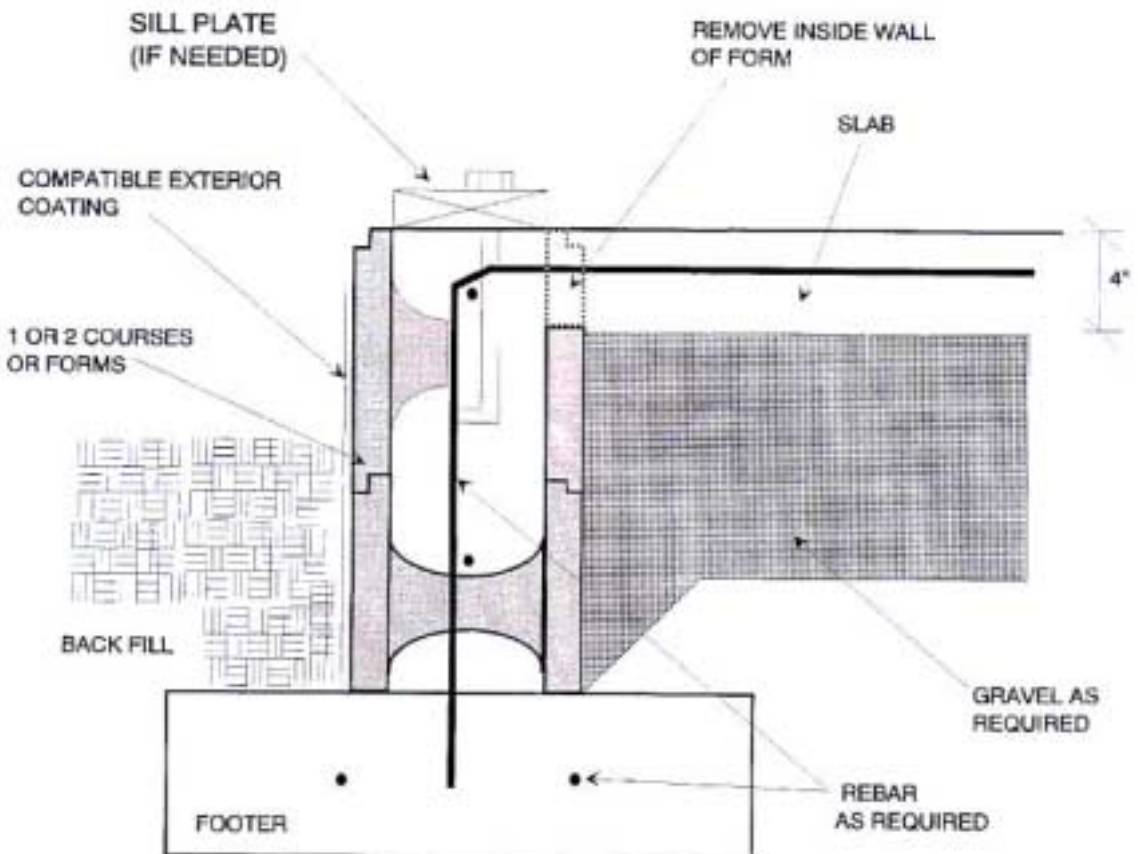

PROPOSED DETAIL
INSULATED SLAB EDGE (SF10 SERIES)

American ConForm Industries' proposed details are for conceptual purposes only. It is the responsibility of the designer, purchaser or installer to confirm the adequacy of American ConForm Industries' proposed details for compliance with the relevant city, county, state or federal building and design codes.

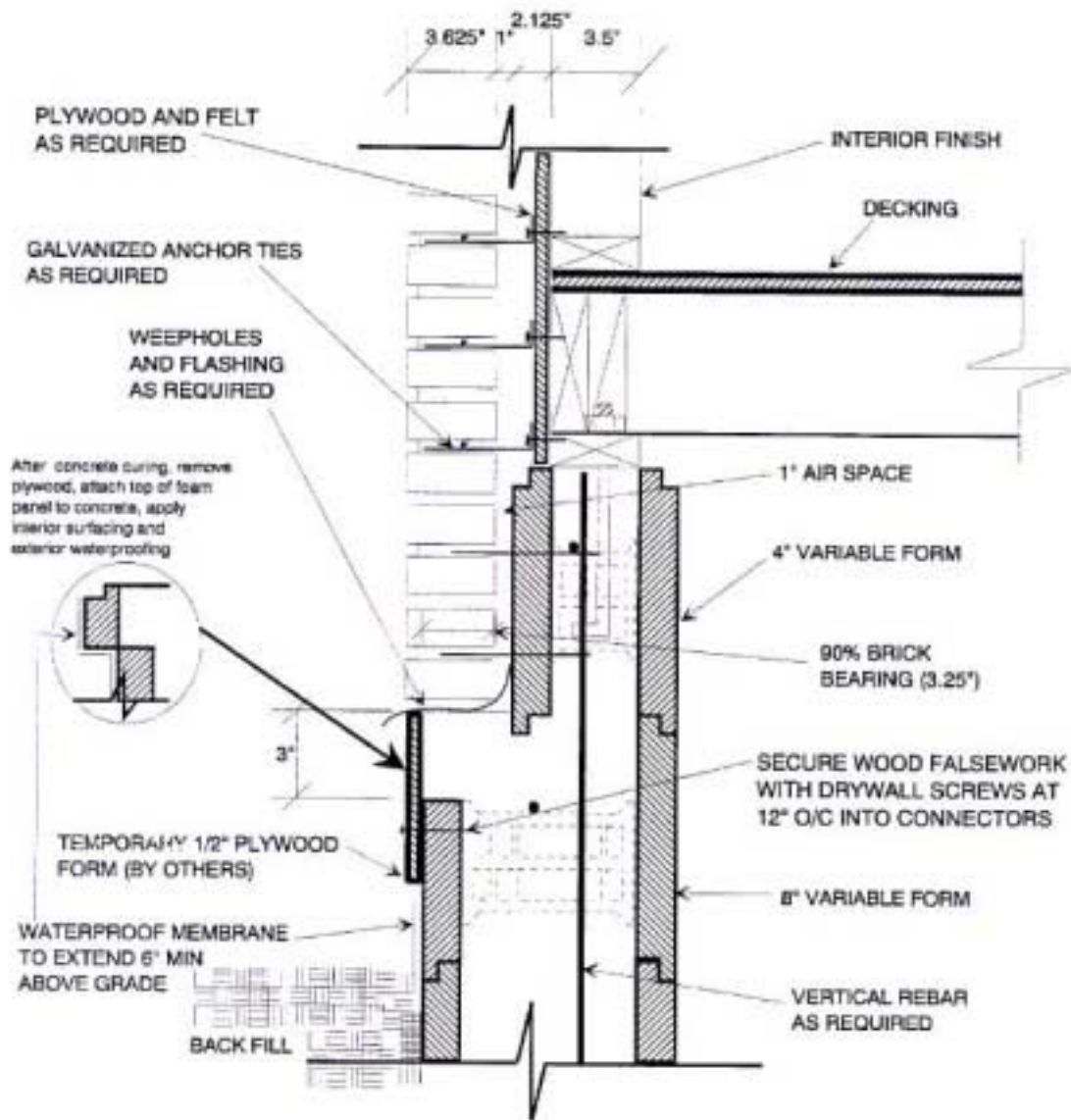

PROPOSED DETAIL

4" BRICK VENEER FOR VWF8/VWF4 STEP WALLS

American ConForm Industries' proposed details are for conceptual purposes only. It is the responsibility of the designer, purchaser or installer to confirm the adequacy of American ConForm Industries' proposed details for compliance with the relevant city, county, state or federal building and design codes.

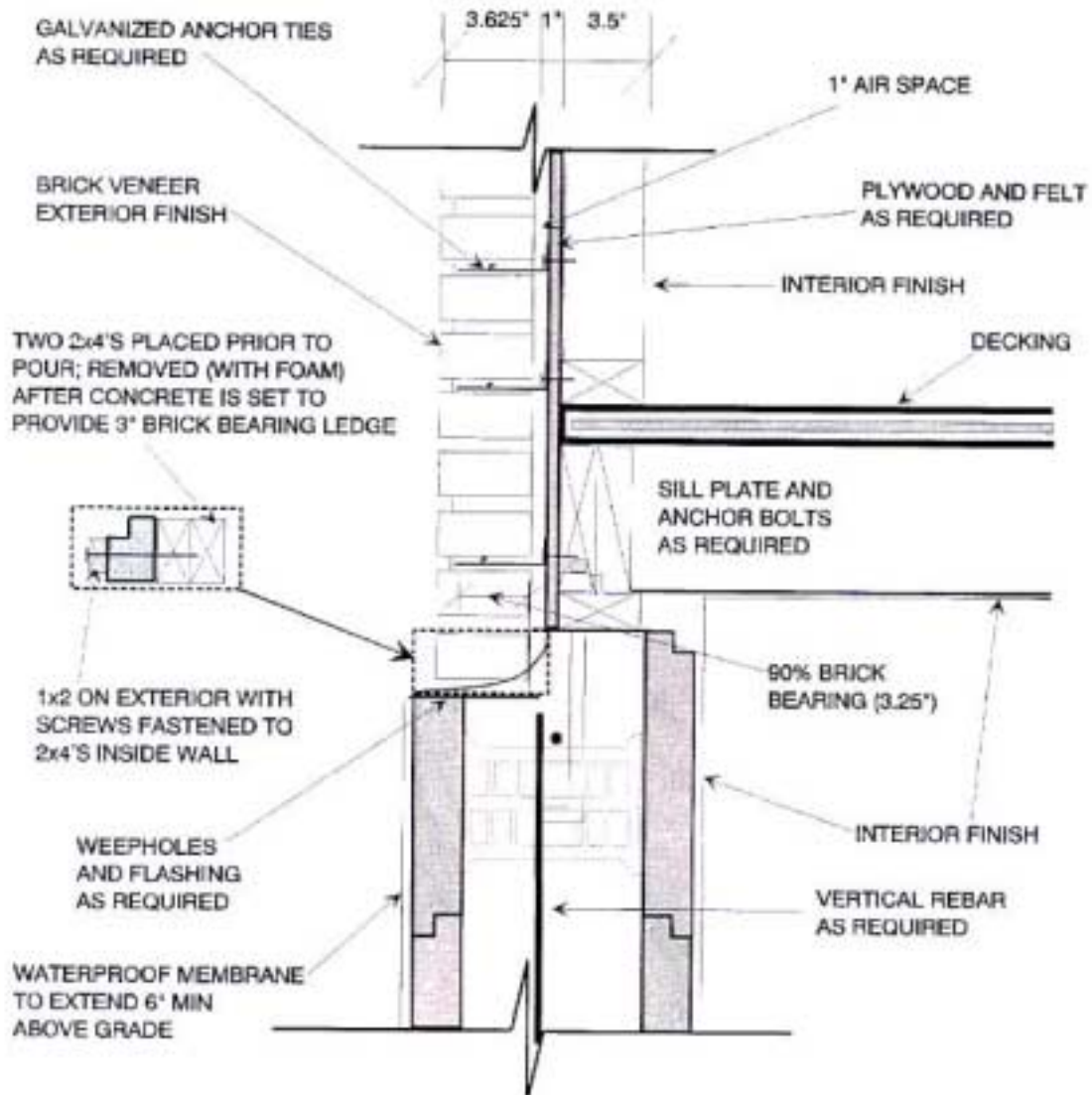

PROPOSED DETAIL 4" BRICK LEDGE

American ConForm Industries' proposed details are for conceptual purposes only. It is the responsibility of the designer, purchaser or installer to confirm the adequacy of American ConForm Industries' proposed details for compliance with the relevant city, county, state or federal building and design codes.

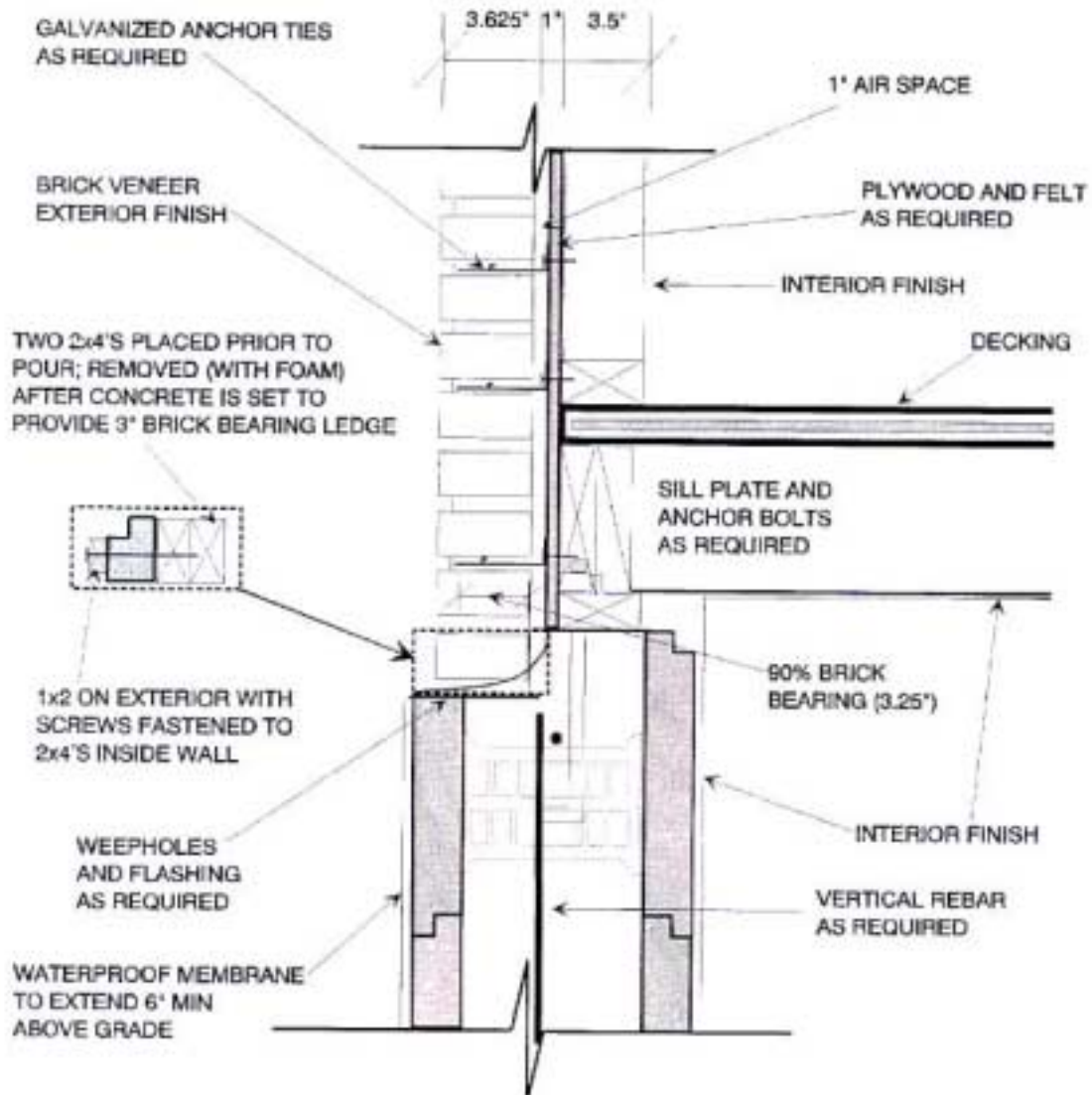

**PROPOSED DETAIL
4" BRICK LEDGE**

American ConForm Industries' proposed details are for conceptual purposes only. It is the responsibility of the designer, purchaser or installer to confirm the adequacy of American ConForm Industries' proposed details for compliance with the relevant city, county, state or federal building and design codes.

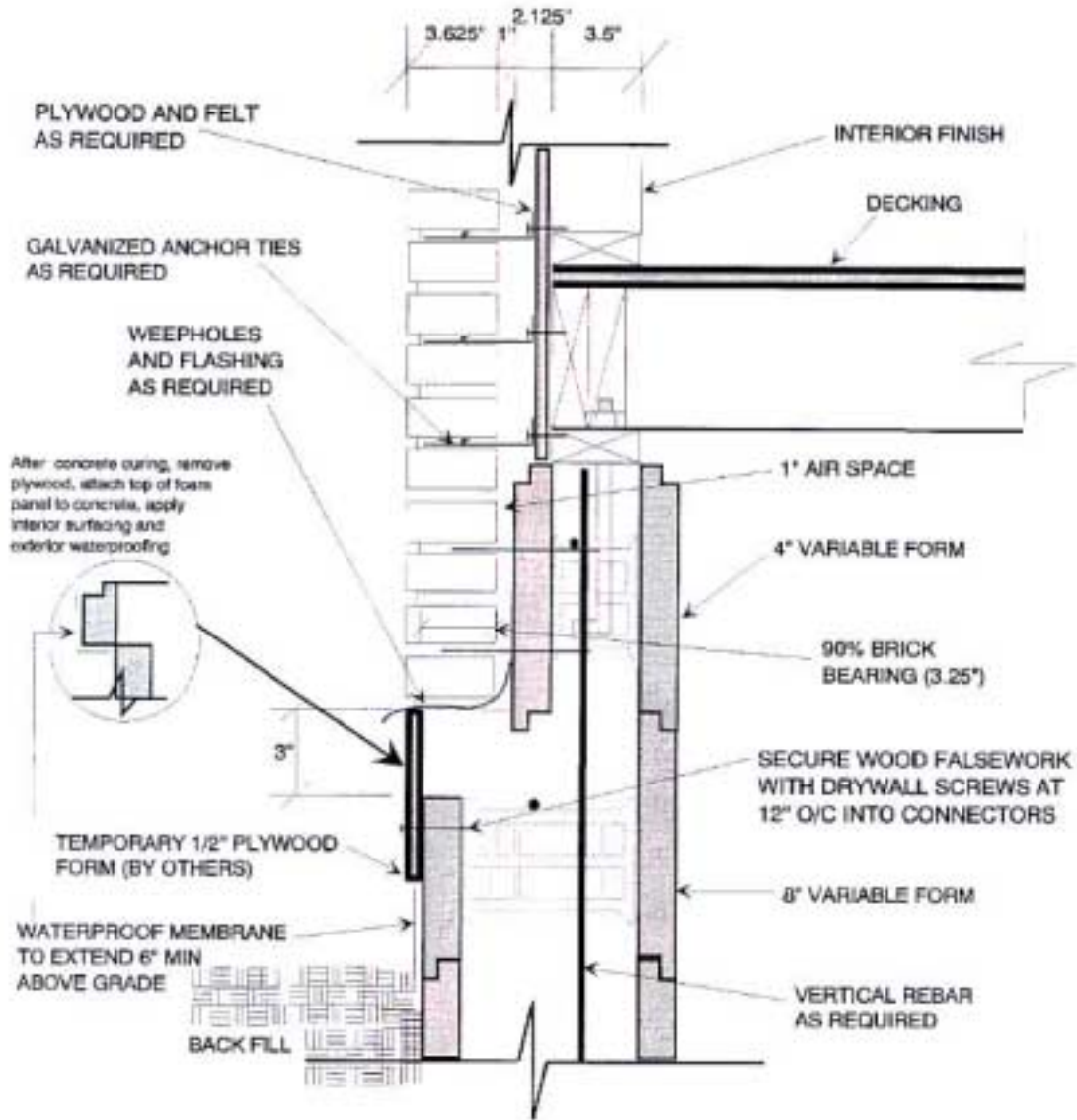

PROPOSED DETAIL

4" BRICK VENEER FOR WVF8/WVF4 STEP WALLS

American ConForm Industries' proposed details are for conceptual purposes only. It is the responsibility of the designer, purchaser or installer to confirm the adequacy of American ConForm Industries' proposed details for compliance with the relevant city, county, state or federal building and design codes.

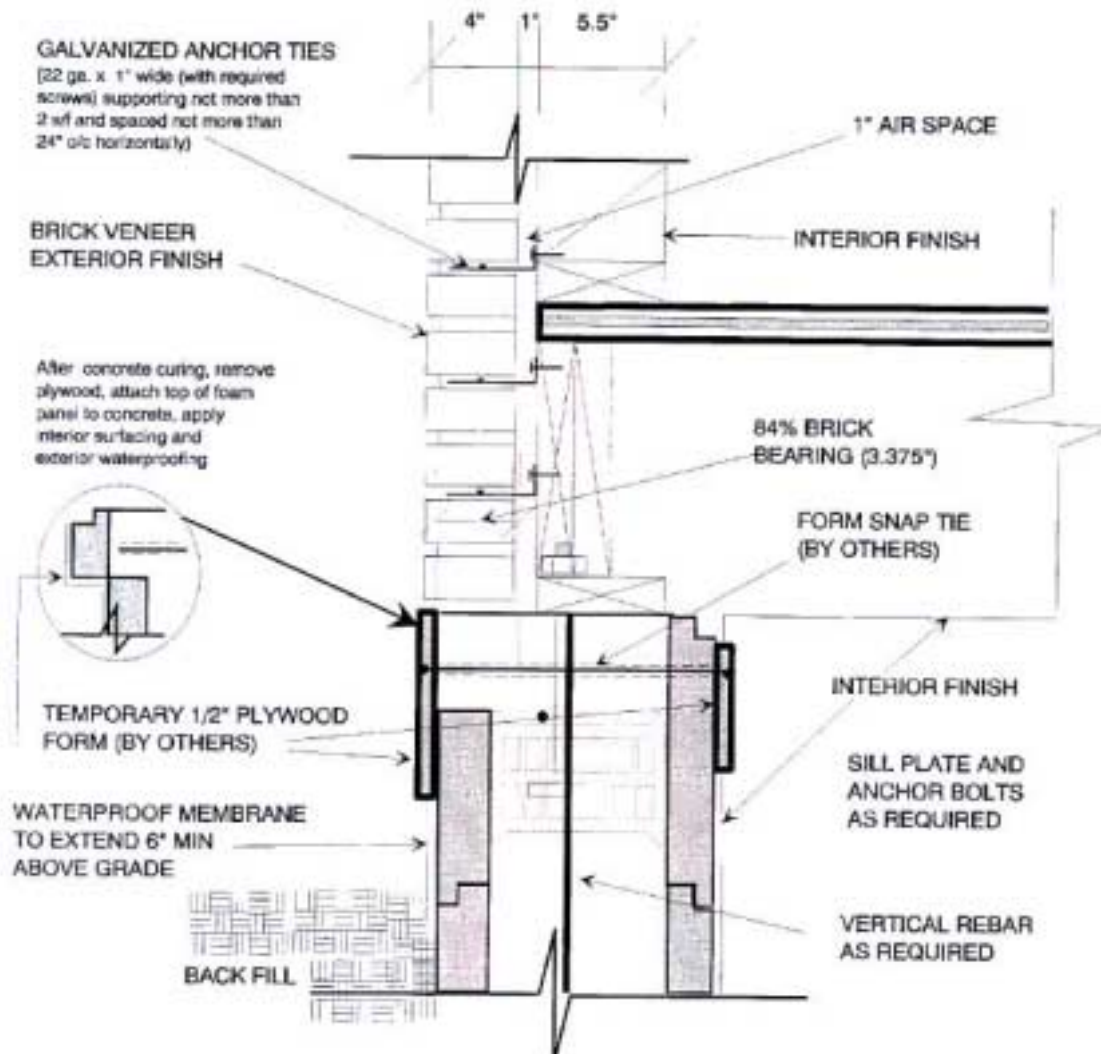

PROPOSED DETAIL

4" BRICK VENEER FOR 2x6 STUD WALLS

American ConForm Industries' proposed details are for conceptual purposes only. It is the responsibility of the designer, purchaser or installer to confirm the adequacy of American ConForm Industries' proposed details for compliance with the relevant city, county, state or federal codes.

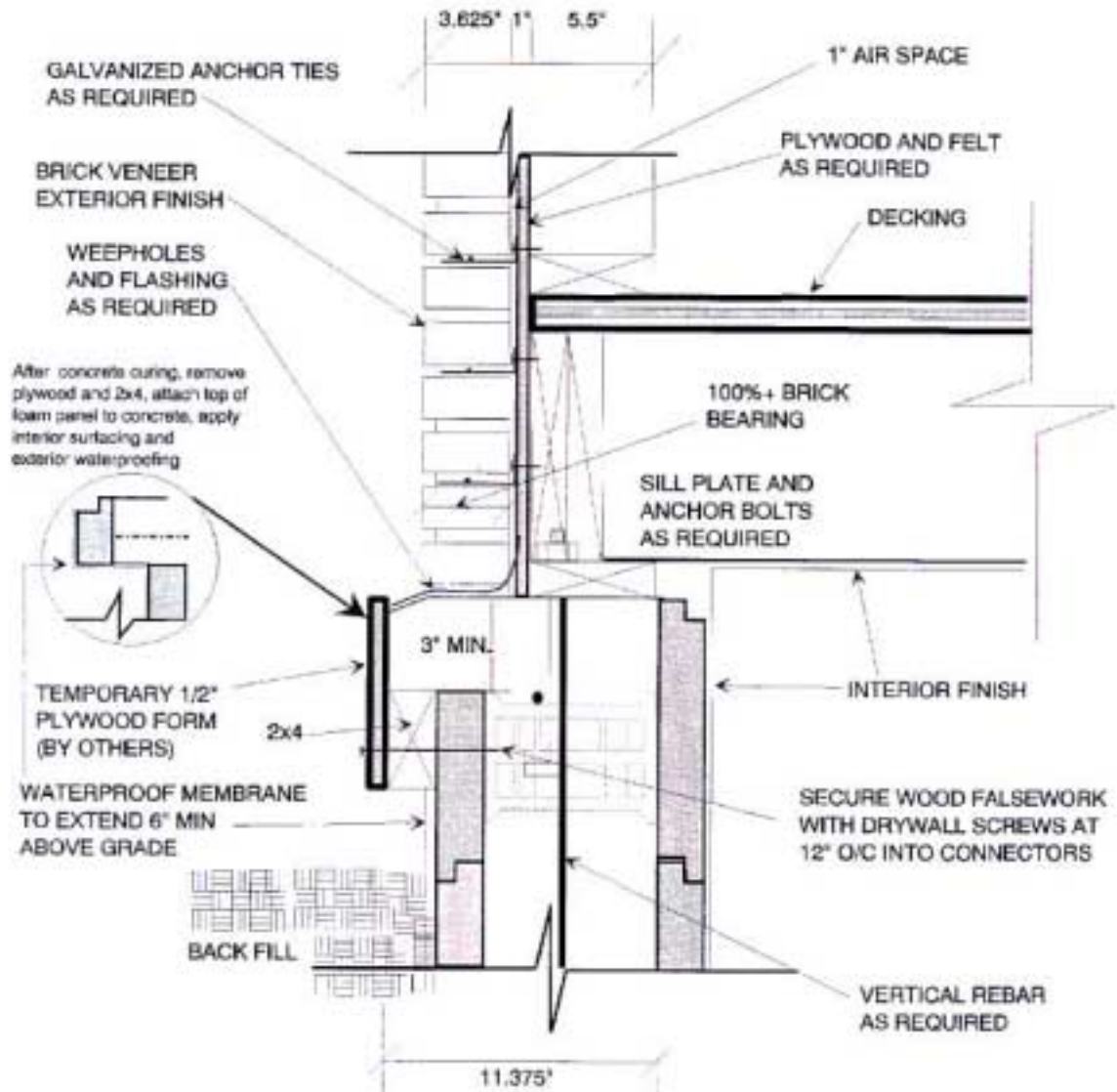

PROPOSED DETAIL

4" BRICK VENEER FOR 2x6 STUD WALLS (100% BEARING)

American ConForm Industries' proposed details are for conceptual purposes only. It is the responsibility of the designer, purchaser or installer to confirm the adequacy of American ConForm Industries' proposed details for compliance with the relevant city, county, state or federal building and design codes.

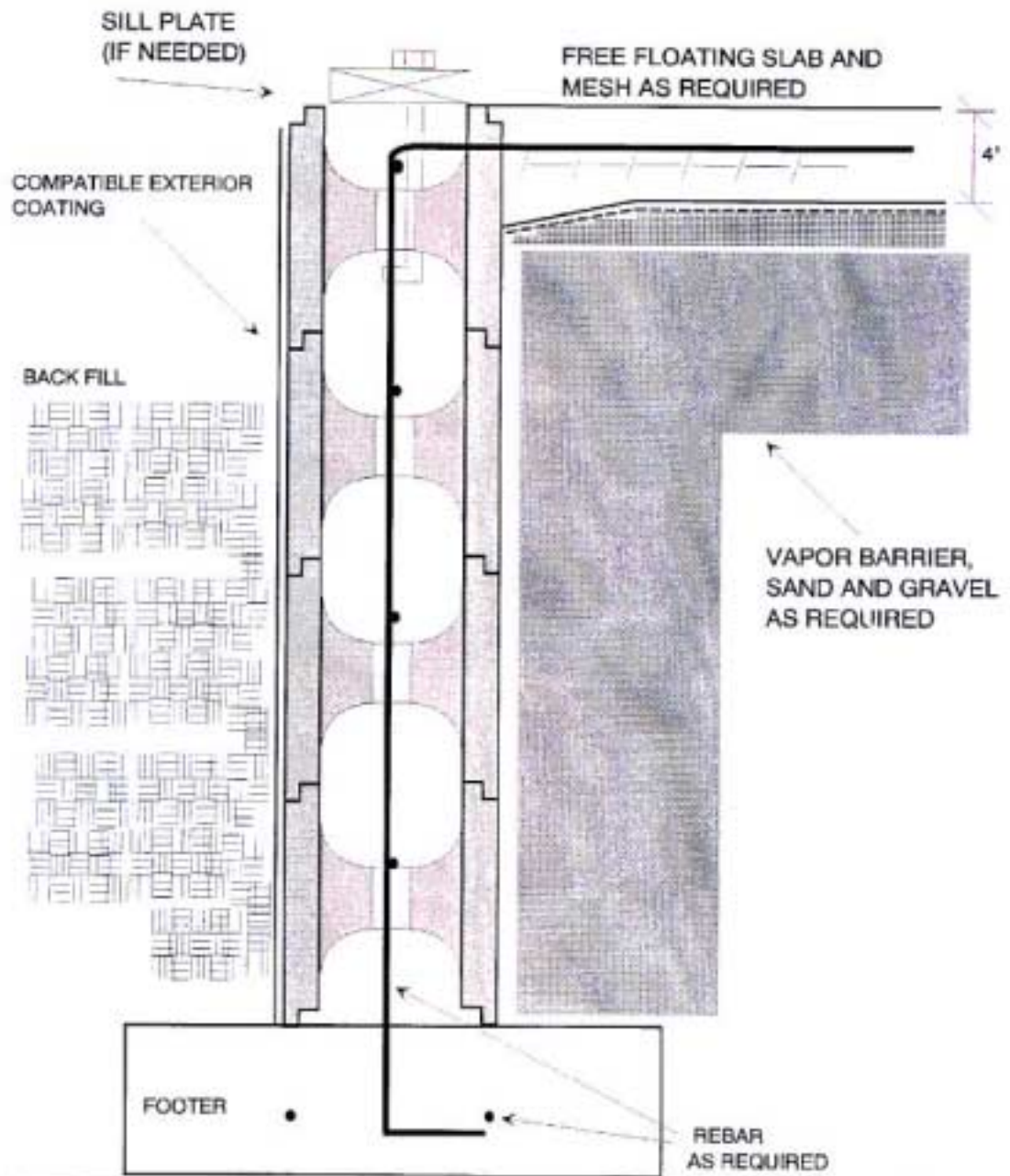

PROPOSED DETAIL INSULATED SLAB EDGE

American ConForm Industries' proposed details are for conceptual purposes only. It is the responsibility of the designer, purchaser or installer to confirm the adequacy of American ConForm Industries' proposed details for compliance with the relevant city, county, state or federal building and design codes.

VWC10 and VWC6 Brick Ledge

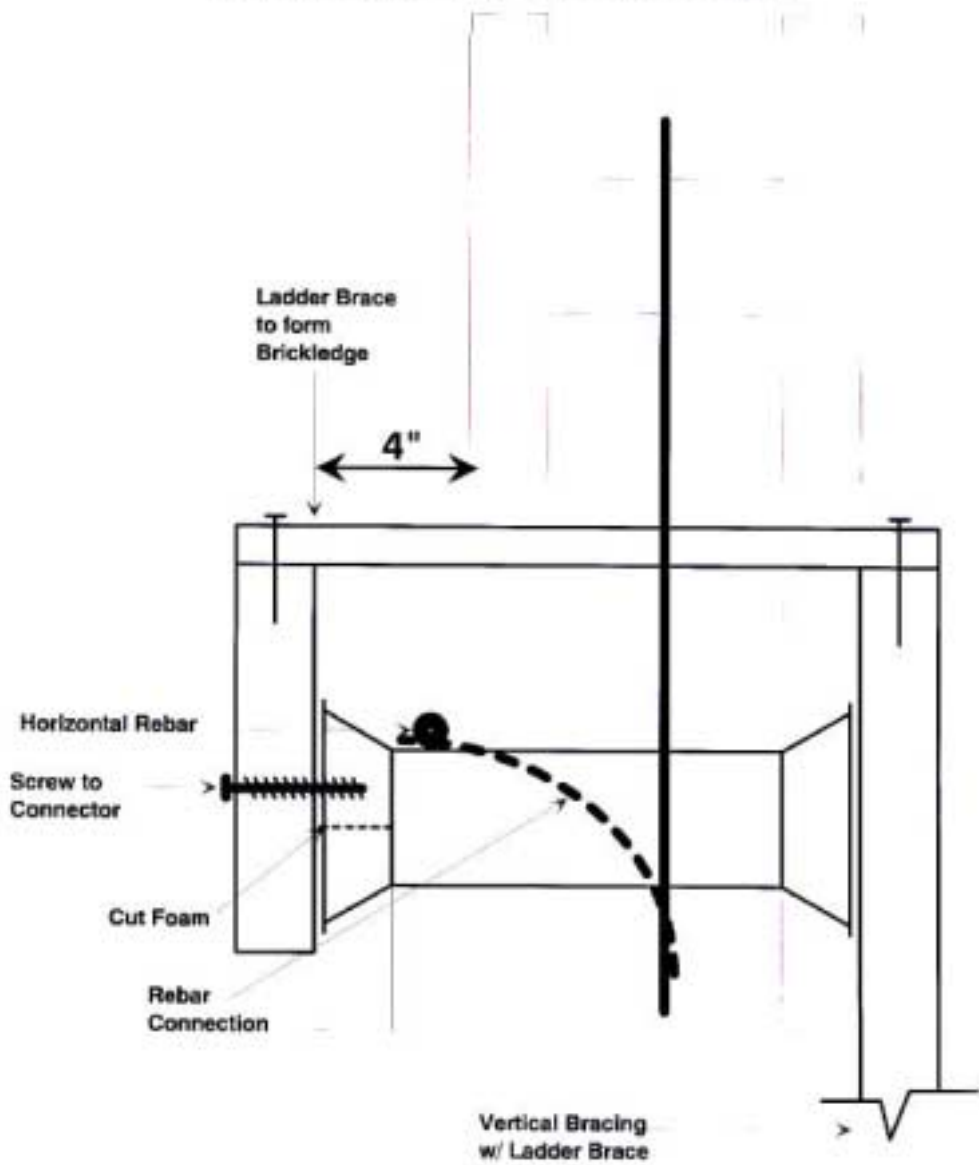

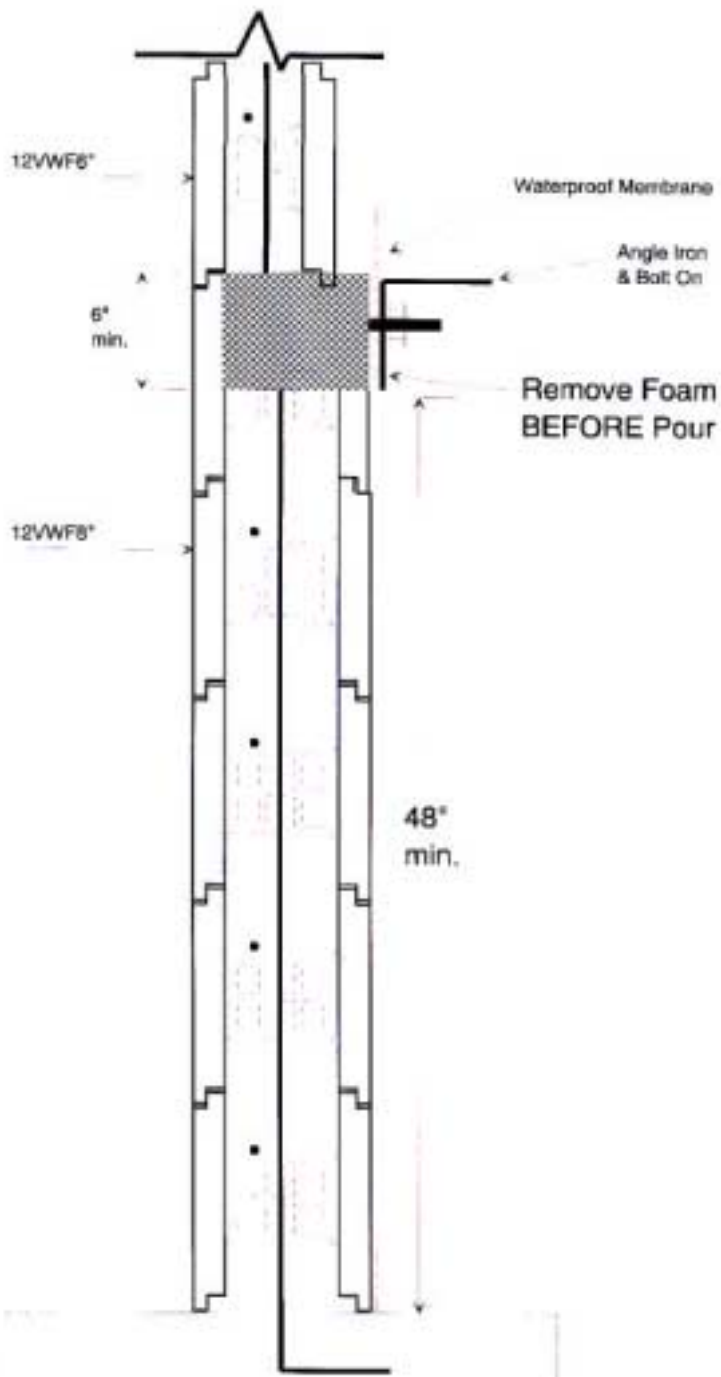

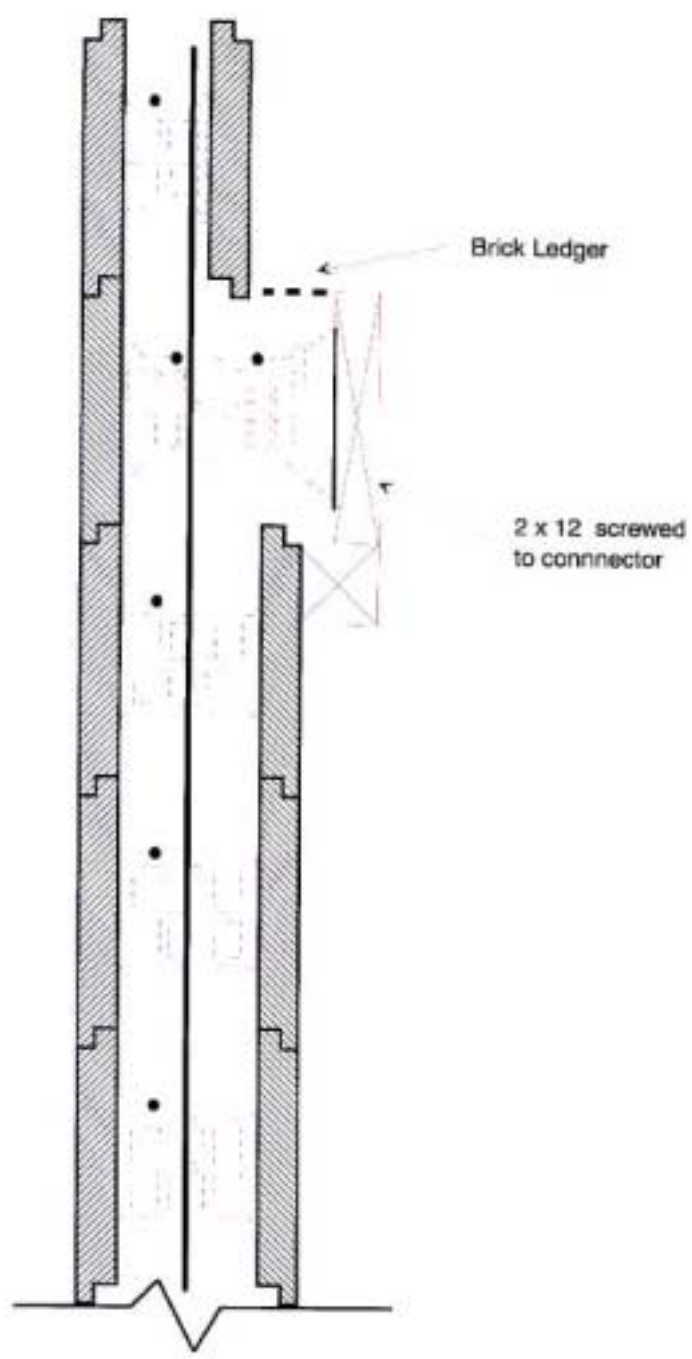

CHAPTER 10

Support Reports



SmartBlock homes exceed all energy and structural requirements.



SmartBlock homes will perform for decades to come.



ICBO Evaluation Service, Inc.

5360 WORKMAN MILL ROAD • WHITTIER, CALIFORNIA 90601-2299

A subsidiary corporation of the International Conference of Building Officials

EVALUATION REPORT

Copyright © 1999 ICBO Evaluation Service, Inc.

ER-4572

Reissued January 1, 1999

Filing Category: DESIGN—Concrete (038)

CONFORM® SMARTBLOCK™ POLYSTYRENE FORMS FOR REINFORCED CONCRETE WALLS

AMERICAN CONFORM INDUSTRIES, INC.
1820 SOUTH SANTA FE STREET
SANTA ANA, CALIFORNIA 92705

1.0 SUBJECT

ConForm® SmartBlock™ Polystyrene Forms for Reinforced Concrete Walls.

2.0 DESCRIPTION

2.1 General:

The ConForm SmartBlock concrete form wall system consists of expanded polystyrene units which serve as insulation and forms for load-bearing and nonload-bearing walls, shear walls, basement walls, retaining walls and foundation walls. The units are manufactured in two basic types, Standard Forms (SF series) and Variable Width Forms (VWF series). The face shell thickness of the forms is $1\frac{3}{4}$ inches for the SF series and 2 or $2\frac{1}{8}$ inches for the VWF series.

The SF series units are 10 inches high by 10 inches wide by 40 inches long with tongue-and-groove attachment at the top and bottom. When laid up, the units form $7\frac{1}{2}$ -inch-by- $6\frac{1}{2}$ -inch rectangular vertical cores at 10 inches on center and $6\frac{1}{2}$ -inch-by- $6\frac{1}{4}$ -inch rectangular horizontal cores at 10 inches on center. The form units remain in place after setting of the concrete and must be protected by approved interior and exterior finish materials.

The VWF series units are 10 or 12 inches high by 40 inches long and have variable widths depending on the thickness of the finished concrete wall, which is from $3\frac{3}{4}$ to $7\frac{3}{4}$ inches. The tongue-and-groove units are interconnected with polypropylene bridge inserts. See Figures 1, 2 and 3 for further details.

2.2 Material:

2.2.1 Conform Units: ConForm's SmartBlock units are molded from expanded polystyrene beads manufactured by BASF Corporation (NER-479) or Huntsman Chemical Corporation (NER-384), having a density of 1.5 to 2.0 pounds per cubic foot with a maximum flame-spread rating and smoke-density rating of 25 and 450, respectively, when tested in accordance with UBC Standard 8-1.

2.2.2 Concrete: Concrete with $\frac{3}{8}$ -inch aggregate for both the SF and the VWF series has a minimum compressive strength of 2,000 pounds per square inch.

2.2.3 Reinforcement: Walls are reinforced with minimum No. 4 deformed bars conforming with ASTM A 615-94, A 616-93, A 617-93 or A 706-92b, having a minimum yield strength of 40,000 psi, or Nos. 5, 6 and 7 deformed bars con-

forming with ASTM A 615-94, A 616-93, A 617-93 or A 706-92b, having minimum yield strength of 60,000 psi.

2.2.4 Other: Wood members for plates or window and door framing are preservative-treated lumber secured in place with galvanized anchor bolts.

2.3 Design:

2.3.1 VWF Series: Concrete walls using the Variable Width Form series units are designed in accordance with Chapter 19 of the *Uniform Building Code*™.

2.3.2 SF Series: Concrete walls using the Standard Form series units are designed in accordance with the following requirements:

2.3.2.1 Height Limitations: Structures are limited to maximum two stories or maximum one basement and one story and maximum 10-foot unsupported wall heights.

2.3.2.2 Axial Load Limitations: Parameter for determining allowable axial load is one of the following:

1. Maximum allowable axial load of 1,500 pounds per foot length of wall.
2. Maximum total roof live and dead load of 50 psf, maximum total floor live and dead load of 50 psf and maximum bearing wall spacing of 20 feet.

2.3.2.3 Wind Load Limitations: Parameter for determining allowable transverse wind load is one of the following:

1. Walls may be constructed in areas with maximum basic wind speed of 100 miles per hour, Exposure C as defined in Section 1616 of the code, provided vertical and horizontal reinforcement is No. 4 bars at maximum 10 inches on center.
2. Moments and shear do not exceed allowable values in Tables 1 and 2.

2.3.3 Opening Reinforcement: Wall openings are vertically and horizontally reinforced with two No. 5 bars extending 24 inches beyond the corners.

2.3.4 Roof and Floor Anchorage: Roofs and floors are anchored and supported at the wall in accordance with Section 1611 of the code. See Figure 4 for typical details.

2.3.5 Shear Wall Limitations: Allowable in-plane shear capacity is 4,800 pounds per linear foot. Maximum wall height to width ratio is 2.5:1 with a minimum shear wall length of 4 feet.

2.3.6 Foundation Anchorage: Anchorage to foundation complies with Section 1915.8 of the code.

2.4 Interior Finish:

Walls must be finished on the interior with $\frac{1}{2}$ -inch-thick gypsum wallboard mechanically attached, using self-tapping screws, to $1\frac{1}{2}$ -inch-wide, No. 26 gage galvanized steel

Evaluation reports of ICBO Evaluation Service, Inc., are issued solely to provide information to Class A members of ICBO, utilizing the code upon which the report is based. Evaluation reports are not to be construed as representing aesthetics or any other attributes not specifically addressed nor as an endorsement or recommendation for use of the subject report.

This report is based upon independent tests or other technical data submitted by the applicant. The ICBO Evaluation Service, Inc., technical staff has reviewed the test results and/or other data, but does not possess test facilities to make an independent verification. There is no warranty by ICBO Evaluation Service, Inc., express or implied, as to any "Finding" or other matter in the report or as to any product covered by the report. This disclaimer includes, but is not limited to, merchantability.

(0.0179-inch) or No. 24 gage (0.02-inch) aluminum strips secured to concrete with 16d nails. The nails are inserted into holes in the metal strip, pushed through the conform unit and are secured with speed washers to prevent withdrawal until the concrete has set. Spacing of anchor plates and fasteners and installation of the gypsum wallboard must comply with Section 2511 of the code. Gypsum board must also be attached to window and door frames.

2.5 Exterior Finish:

Walls are covered on the exterior with a weather-resistive covering in accordance with the code and/or an evaluation report. Suitable finishes include, but are not limited to: STO Corp. R-wall Finish (Evaluation Report ER-3617) and STO Corp. STO Exterior Wall Finish (Evaluation Report ER-3906). Exterior wall covering must be recognized in individual evaluation reports for the required design wind pressures.

2.6 Foundation Walls:

See Figures 5 and 6 for typical foundation walls constructed with SF series units.

2.7 Retaining Walls:

The walls may be used as retaining walls with reinforcement, provided they are designed in accordance with accepted engineering principles. See Tables 4, 6 and 8 for reinforcing requirements.

2.8 Basement Walls:

ConForm SmartBlock units may be used for basement walls. When the SF series units are used, the basement is considered the first story of the two-story limitation specified in Section 2.3.2, Item 1. See Tables 3, 5 and 7 for reinforcing requirements. Waterproofing and damp-proofing of basement walls must be in accordance with Appendix Chapter 18 of the code and the manufacturer's instructions. Products to be used for waterproofing are Sealtight Mel-Rol waterproofing and liquid membrane without primers or mastics manufactured by W. R. Meadows Inc., or Henry No. 107 asphalt emulsion manufactured by Henry Company or Polyguard 650 without primers manufactured by Polyguard Products, Inc. See Figures 7 and 8 for further details.

2.9 Crawl Spaces:

ConForm units exposed to the inside may be used for walls forming underfloor crawl spaces, contingent on the following conditions:

1. Entry to the crawl space is only to service utilities.
2. There are no interconnected basement areas.
3. Air in the crawl space is not circulated to other parts of the building.
4. Ventilation complies with Section 2306.7 of the code.
5. Block units exposed to crawl spaces are limited to those manufactured with BASF Styropor or Huntsman expandable polystyrene beads.

2.10 Fire-resistive Construction:

Concrete walls constructed with VWF series 5³/₄-inch-thick and 7³/₄-inch-thick units, with one layer of 1/2-inch-thick gypsum wallboard attached as noted in Section 2.4, are recognized for fire-resistive ratings of up to 4 hours.

2.11 Special Inspection:

Special inspection is required as noted in Sections 1701.5.1 and 1701.5.4 of the code at the time of placing of reinforcing

steel and pouring of concrete. The inspector is required to inspect pouring and consolidation of concrete to ensure proper filling of voids at each level, since the forms remain permanently in place.

Taking of test specimens for stem wall foundation construction as noted in Figure 5 is not necessary.

When approved by the building official, special inspection is not necessary for installation of single-story, maximum 8-foot-high walls housing Group R, Division 3 or Group U, Division 1 Occupancies, provided the following conditions are met:

1. Maximum height of individual concrete pour is 48 inches.
2. Installation is by trained installers approved by the manufacturer.
3. Half the allowable design stresses are used for the design of the walls.

2.12 Identification:

Each package bears a label noting the product name, address of the manufacturer, flame-spread and smoke-density ratings and the name and logo of the quality control agency, Underwriters Laboratories Inc.

3.0 EVIDENCE SUBMITTED

Calculations and structural details; reports of tests in accordance with applicable portions of the ICBO ES Acceptance Criteria for Foam Plastic Insulation (AC12), dated June 1998, and the ICBO ES Acceptance Criteria for Concrete and Concrete Masonry Wall Systems (AC15), dated June 1987; reports of fire tests in accordance with UBC Standards 7-1 and 26-3; and a quality control manual.

4.0 FINDINGS

That the ConForm's® SmartBlock™ units described in this report comply with the 1997 Uniform Building Code™, subject to the following conditions:

- 4.1 They are manufactured, identified and installed in accordance with the manufacturer's instructions and this report.
- 4.2 Walls using the SF series forms are limited to two-story or maximum one basement and one-story structures with a maximum unsupported wall height of 10 feet.
- 4.3 Walls using the forms are considered combustible construction.
- 4.4 Plans and calculations are submitted for building department approval for each structure, except that calculations need not be submitted when using the VWF series walls as foundations for stud bearing walls as noted in Table 18-I-C of the code.
- 4.5 The forms are separated from the building interior with minimum 1/2-inch-thick regular gypsum wallboard installed as set forth in this report.
- 4.6 Special inspection is provided in accordance with Section 2.11 of this report.
- 4.7 The units are manufactured in Santa Ana, California, under a quality control program with inspections by Underwriters Laboratories Inc. (NER-QA403).

This report is subjected to re-examination in two years.

SI CONVERSIONS FOR TEXT

0.02 inch = 0.51 mm	$\frac{3}{8}$ inch = 10 mm	$\frac{1}{2}$ inch = 12.7 mm	$1\frac{1}{2}$ inches = 38 mm
$1\frac{3}{4}$ inches = 44.5 mm	2 inches = 51 mm	$2\frac{1}{8}$ inches = 54 mm	$3\frac{3}{4}$ inches = 95 mm
$5\frac{3}{4}$ inches = 146 mm	$6\frac{1}{4}$ inches = 159 mm	$6\frac{1}{2}$ inches = 165 mm	$7\frac{1}{2}$ inches = 191 mm
$7\frac{3}{4}$ inches = 197 mm	10 inches = 254 mm	12 inches = 305 mm	20 inches = 508 mm
24 inches = 610 mm	40 inches = 1016 mm	48 inches = 1219 mm	—
2,000 psi = 13.8 MPa	40,000 psi = 276 MPa	60,000 psi = 413 MPa	—
4 feet = 1219 mm	8 feet = 2438 mm	10 feet = 3048 mm	20 feet = 6096 mm
50 psf = 2394 Pa	—	—	—
1.5 lbs./ft. ³ = 24 kg/m ³	2.0 lbs./ft. ³ = 32 kg/m ³	—	—
100 mph = 161 km/h	—	—	—
1,500 lbs. per ft. = 21 891 N/m	4,800 lbs. per ft. = 70 051 N/m	—	—

TABLE 1—SF 10 WALLS WITH REINFORCEMENT AT EDGE OF WALL^{1,2,3,4}

VERTICAL REINFORCING STEEL ^{5,6}	ALLOWABLE MOMENT (ft.-lbs./ft.)	ALLOWABLE SHEAR (lbs./ft.)
No. 4 at 10" o.c.	3,194	3,250
No. 5 at 10" o.c.	6,625	3,207
No. 6 at 10" o.c.	7,341	2,822

For **SI**: 1 inch = 25.4 mm, 1 (ft.-lb.)/ft. = 1.355818 N-m/m, 1 lb./ft. = 14.5939 N/m.

¹Minimum compressive strength of concrete is 2,000 psi.

²Horizontal reinforcement is No. 4 at 10 inches on center or No. 6 at 20 inches on center.

³Walls to be anchored to all floors and roofs as specified in Section 1611 of the code. Walls shall be interconnected at corners by embedding and lapping the reinforcement as specified in Section 1912 of the code.

⁴When used as basement walls, the basement floor must be poured and the first floor in place prior to backfilling, or adequate temporary shoring must be installed.

⁵Minimum yield strength of No. 4 bar is 40,000 psi and Nos. 5 and 6 bars is 60,000 psi.

⁶Reinforcing steel must be placed on the tension side of the wall, and the outer surface of the steel is covered by $1\frac{1}{2}$ -inch-thick (38 mm) concrete. If wall bears load from both sides, reinforcing steel must be in the center of wall and allowable values in Table 2 apply.

TABLE 2—SF 10 WALLS WITH REINFORCEMENT AT CENTER OF WALL^{1,2,3,4}

VERTICAL REINFORCING STEEL ⁵	ALLOWABLE MOMENT (ft.-lbs./ft.)	ALLOWABLE SHEAR (lbs./ft.)
No. 4 at 10" o.c.	2,114	2,223
No. 5 at 10" o.c.	4,219	2,223

For **SI**: 1 inch = 25.4 mm, 1 (ft.-lb.)/ft. = 1.355818 N-m/m, 1 lb./ft. = 14.5939 N/m.

¹Minimum compressive strength of concrete is 2,000 psi.

²Horizontal reinforcement is No. 4 at 10 inches on center or No. 6 at 20 inches on center.

³Walls to be anchored to all floors and roofs as specified in Section 1611 of the code. Walls shall be interconnected at corners by embedding and lapping the reinforcement as specified in Section 1912 of the code.

⁴When used as basement walls, the basement floor must be poured and the first floor in place prior to backfilling, or adequate temporary shoring must be installed.

⁵Minimum yield strength of No. 4 bar is 40,000 psi and Nos. 5 and 6 bars is 60,000 psi.

TABLE 3—10VWF8 AND 12VWF8 BASEMENT WALL—WALL RESTRAINED AT TOP AND BOTTOM^{1,2,3,4,5,6,7}

WALL HEIGHT (Feet)	EQUIVALENT FLUID PRESSURE (lbs./ft. ² /ft.)											
	30	35	40	45	50	55	60	65	70	75	80	85
6	No. 4 at 18" o.c.	No. 4 at 18" o.c.	No. 4 at 18" o.c.	No. 4 at 18" o.c.	No. 4 at 18" o.c.	No. 4 at 18" o.c.	No. 4 at 18" o.c.	No. 4 at 18" o.c.	No. 4 at 18" o.c.	No. 4 at 18" o.c.	No. 4 at 18" o.c.	No. 4 at 18" o.c.
7	No. 4 at 18" o.c.	No. 4 at 18" o.c.	No. 4 at 18" o.c.	No. 4 at 18" o.c.	No. 4 at 18" o.c.	No. 4 at 18" o.c.	No. 4 at 18" o.c.	No. 4 at 18" o.c.	No. 4 at 12" o.c.	No. 4 at 12" o.c.	No. 4 at 12" o.c.	No. 4 at 12" o.c.
8	No. 4 at 18" o.c.	No. 4 at 18" o.c.	No. 4 at 18" o.c.	No. 4 at 12" o.c.	No. 4 at 12" o.c.	No. 4 at 12" o.c.	No. 4 at 12" o.c.	No. 4 at 12" o.c.	No. 5 at 18" o.c.	No. 5 at 18" o.c.	No. 5 at 18" o.c.	No. 5 at 18" o.c.
9	No. 4 at 12" o.c.	No. 4 at 12" o.c.	No. 4 at 12" o.c.	No. 5 at 18" o.c.	No. 5 at 18" o.c.	No. 5 at 18" o.c.	No. 5 at 18" o.c.	No. 5 at 18" o.c.	No. 5 at 12" o.c.	No. 5 at 12" o.c.	No. 5 at 12" o.c.	No. 5 at 12" o.c.
10	No. 4 at 12" o.c.	No. 5 at 18" o.c.	No. 5 at 18" o.c.	No. 5 at 18" o.c.	No. 5 at 12" o.c.	No. 5 at 12" o.c.	No. 5 at 12" o.c.	No. 5 at 12" o.c.	No. 5 at 12" o.c.	No. 5 at 12" o.c.	No. 6 at 12" o.c.	No. 6 at 12" o.c.
11	No. 5 at 18" o.c.	No. 5 at 18" o.c.	No. 5 at 12" o.c.	No. 5 at 12" o.c.	No. 5 at 12" o.c.	No. 6 at 12" o.c.	No. 6 at 12" o.c.	No. 7 at 12" o.c.	No. 7 at 12" o.c.	No. 5 at 6" o.c.	N/A	N/A
12	No. 6 at 18" o.c.	No. 6 at 12" o.c.	No. 6 at 12" o.c.	No. 6 at 12" o.c.	No. 7 at 12" o.c.	No. 7 at 12" o.c.	No. 5 at 6" o.c.	No. 5 at 6" o.c.	N/A	N/A	N/A	N/A

For **SI**: 1 inch = 25.4 mm, 1 foot = 304.8 mm, 1 psf/ft. = 47.8803 Pa/m.

¹Minimum compressive strength of concrete is 2,000 psi.

²Minimum yield strength of No. 4 bar is 40,000 psi and Nos. 5, 6 and 7 bars is 60,000 psi.

³Reinforcing steel must be placed on the tension side of the wall, and the outer surface of the steel is covered by $1\frac{1}{2}$ -inch-thick concrete.

⁴Horizontal reinforcement is No. 4 at 10 inches on center or No. 5 at 12 inches on center.

⁵Walls to be anchored to all floors and roofs as specified in Section 1611 of the code. Walls shall be interconnected at corners by embedding and lapping the reinforcement as specified in Section 1912 of the code.

⁶The basement floor must be poured and the first floor in place prior to backfilling, or adequate temporary shoring must be installed.

⁷Calculations are based on maximum two floors above the basement.

N/A = Not available.

TABLE 4—10VWF8 AND 12VWF8 RETAINING WALL—WALL UNRESTRAINED AT TOP^{1,2,3,4}

WALL HEIGHT (feet)	EQUIVALENT FLUID PRESSURE (lbs./ft. ² /ft.)											
	30	35	40	45	50	55	60	65	70	75	80	85
6	No. 4 at 18" o.c.	No. 4 at 18" o.c.	No. 4 at 12" o.c.	No. 4 at 12" o.c.	No. 4 at 12" o.c.	No. 4 at 12" o.c.	No. 5 at 18" o.c.	No. 5 at 18" o.c.	No. 5 at 18" o.c.	No. 5 at 18" o.c.	No. 5 at 18" o.c.	No. 5 at 18" o.c.
7	No. 5 at 18" o.c.	No. 5 at 18" o.c.	No. 5 at 18" o.c.	No. 5 at 18" o.c.	No. 5 at 18" o.c.	No. 5 at 12" o.c.	No. 5 at 12" o.c.	No. 5 at 12" o.c.	No. 5 at 12" o.c.	No. 5 at 12" o.c.	No. 6 at 12" o.c.	No. 6 at 12" o.c.
8	No. 5 at 18" o.c.	No. 5 at 18" o.c.	No. 5 at 12" o.c.	No. 5 at 12" o.c.	No. 5 at 12" o.c.	No. 6 at 12" o.c.	No. 6 at 12" o.c.	No. 7 at 12" o.c.	No. 7 at 12" o.c.	No. 7 at 12" o.c.	No. 7 at 12" o.c.	No. 7 at 6" o.c.
9	No. 5 at 12" o.c.	No. 5 at 12" o.c.	No. 6 at 12" o.c.	No. 6 at 12" o.c.	No. 7 at 12" o.c.	No. 7 at 12" o.c.	No. 5 at 6" o.c.	No. 5 at 6" o.c.	No. 6 at 6" o.c.	No. 5 at 4" o.c.	N/A	N/A
10	No. 6 at 12" o.c.	No. 7 at 12" o.c.	No. 7 at 12" o.c.	No. 5 at 6" o.c.	No. 6 at 6" o.c.	No. 6 at 6" o.c.	No. 5 at 4" o.c.	N/A	N/A	N/A	N/A	N/A
11	No. 7 at 12" o.c.	No. 5 at 6" o.c.	No. 6 at 6" o.c.	No. 5 at 4" o.c.	No. 5 at 4" o.c.	N/A	N/A	N/A	N/A	N/A	N/A	N/A
12	No. 6 at 6" o.c.	No. 5 at 4" o.c.	N/A	N/A	N/A	N/A	N/A	N/A	N/A	N/A	N/A	N/A

For **SI**: 1 inch = 25.4 mm, 1 foot = 304.8 mm, 1 psf/ft. = 47.8803 Pa/m.

¹Minimum compressive strength of concrete is 2,000 psi.

²Minimum yield strength of No. 4 bar is 40,000 psi and Nos. 5, 6 and 7 bars is 60,000 psi.

³Reinforcing steel placed near the edge of wall side facing the soil such that the outer surface of the steel is covered by 1½-inch-thick concrete.

⁴Horizontal reinforcement is No. 4 at 10 inches on center or No. 5 at 12 inches on center.

N/A = Not available.

TABLE 5—10VWF6 AND 12VWF6 BASEMENT WALL—WALL RESTRAINED AT TOP AND BOTTOM^{1,2,3,4,5,6,7}

BASEMENT WALL HEIGHT (feet)	EQUIVALENT FLUID PRESSURE (lbs./ft. ² /ft.)											
	30	35	40	45	50	55	60	65	70	75	80	85
6	No. 4 at 17.25" o.c.	No. 4 at 17.25" o.c.	No. 4 at 17.25" o.c.	No. 4 at 17.25" o.c.	No. 4 at 17.25" o.c.	No. 4 at 17.25" o.c.	No. 4 at 17.25" o.c.	No. 4 at 17.25" o.c.	No. 5 at 17.25" o.c.	No. 5 at 17.25" o.c.	No. 5 at 17.25" o.c.	No. 5 at 17.25" o.c.
7	No. 4 at 17.25" o.c.	No. 4 at 17.25" o.c.	No. 4 at 17.25" o.c.	No. 5 at 17.25" o.c.	No. 5 at 17.25" o.c.	No. 5 at 17.25" o.c.	No. 5 at 17.25" o.c.	No. 5 at 17.25" o.c.	No. 5 at 17.25" o.c.	No. 5 at 17.25" o.c.	No. 5 at 17.25" o.c.	No. 5 at 17.25" o.c.
8	No. 5 at 17.25" o.c.	No. 5 at 17.25" o.c.	No. 5 at 17.25" o.c.	No. 5 at 17.25" o.c.	No. 5 at 17.25" o.c.	No. 5 at 17.25" o.c.	No. 5 at 17.25" o.c.	No. 5 at 12" o.c.	No. 5 at 12" o.c.	No. 5 at 12" o.c.	No. 5 at 12" o.c.	No. 5 at 12" o.c.
9	No. 5 at 17.25" o.c.	No. 5 at 17.25" o.c.	No. 5 at 17.25" o.c.	No. 5 at 12" o.c.	No. 5 at 12" o.c.	No. 5 at 12" o.c.	No. 5 at 12" o.c.	No. 6 at 12" o.c.	No. 5 at 6" o.c.	No. 5 at 6" o.c.	N/A	N/A
10	No. 5 at 17.25" o.c.	No. 5 at 12" o.c.	No. 5 at 12" o.c.	No. 5 at 6" o.c.	No. 5 at 6" o.c.	No. 5 at 6" o.c.	No. 5 at 6" o.c.	N/A	N/A	N/A	N/A	N/A
11	No. 5 at 12" o.c.	No. 5 at 12" o.c.	No. 5 at 6" o.c.	No. 5 at 6" o.c.	No. 5 at 6" o.c.	N/A	N/A	N/A	N/A	N/A	N/A	N/A
12	No. 5 at 6" o.c.	No. 5 at 6" o.c.	No. 5 at 6" o.c.	N/A	N/A	N/A	N/A	N/A	N/A	N/A	N/A	N/A

For **SI**: 1 inch = 25.4 mm, 1 foot = 304.8 mm, 1 psf/ft. = 47.8803 Pa/m.

¹Minimum compressive strength of concrete is 2,000 psi.

²Minimum yield strength of No. 4 bar is 40,000 psi and Nos. 5, 6 and 7 bars is 60,000 psi.

³Reinforcing steel must be placed on the tension side of the wall, and the outer surface of the steel is covered by 1½-inch-thick (38 mm) concrete.

⁴Horizontal reinforcement is No. 4 at 10 inches on center or No. 5 at 12 inches on center.

⁵Walls to be anchored to all floors and roofs as specified in Section 1611 of the code. Walls shall be interconnected at corners by embedding and lapping the reinforcement as specified in Section 1912 of the code.

⁶The basement floor must be poured and the first floor in place prior to backfilling, or adequate temporary shoring must be installed.

⁷Calculations are based on maximum two floors above basement.

N/A = Not available.

TABLE 6—10VWF6 AND 12VWF6 RETAINING WALL—WALL UNRESTRAINED AT TOP 1,2,3,4

WALL HEIGHT (feet)	EQUIVALENT FLUID PRESSURE (lbs./ft. ² /ft.)											
	30	35	40	45	50	55	60	65	70	75	80	85
6	No. 5 at 17.25" o.c.	No. 5 at 17.25" o.c.	No.5 at 17.25" o.c.	No. 5 at 17.25" o.c.	No. 5 at 17.25" o.c.	No. 5 at 17.25" o.c.	No. 5 at 12" o.c.	No. 5 at 12" o.c.	No. 5 at 12" o.c.	No. 5 at 12" o.c.	No. 6 at 12" o.c.	No. 6 at 12" o.c.
7	No. 5 at 17.25" o.c.	No. 5 at 12" o.c.	No. 5 at 12" o.c.	No. 5 at 12" o.c.	No. 6 at 12" o.c.	No. 6 at 12" o.c.	No. 5 at 6" o.c.	No. 5 at 6" o.c.	No. 5 at 6" o.c.	No. 5 at 6" o.c.	No. 5 at 6" o.c.	No. 5 at 6" o.c.
8	No. 5 at 12" o.c.	No. 5 at 12" o.c.	No. 5 at 6" o.c.	No. 5 at 6" o.c.	No. 5 at 6" o.c.	No. 5 at 6" o.c.	N/A	N/A	N/A	N/A	N/A	N/A
9	No. 5 at 6" o.c.	No. 5 at 6" o.c.	No. 5 at 6" o.c.	N/A	N/A	N/A	N/A	N/A	N/A	N/A	N/A	N/A

For **SI**: 1 inch = 25.4 mm, 1 foot = 304.8 mm, 1 psf/ft. = 47.8803 Pa/m.

¹Minimum compressive strength of concrete is 2,000 psi.

²Minimum yield strength of No. 4 bar is 40,000 psi and Nos. 5 and 6 bars is 60,000 psi.

³Reinforcing steel placed near the edge of wall side facing the soil such that the outer surface of the steel is covered by 1½-inch-thick concrete.

⁴Horizontal reinforcement is No. 4 at 10 inches on center or No. 5 at 12 inches on center.

N/A = Not available.

TABLE 7—SF10 BASEMENT WALL—WALL RESTRAINED AT TOP AND BOTTOM 1,2,3,4,5,6

WALL HEIGHT (feet)	EQUIVALENT FLUID PRESSURE (lbs./ft. ² /ft.)											
	30	35	40	45	50	55	60	65	70	75	80	85
6	No. 4 at 10" o.c.	No. 4 at 10" o.c.	No. 4 at 10" o.c.	No. 4 at 10" o.c.	No. 4 at 10" o.c.	No. 4 at 10" o.c.	No. 4 at 10" o.c.	No. 4 at 10" o.c.	No. 4 at 10" o.c.	No. 4 at 10" o.c.	No.4 at 10" o.c.	No.4 at 10" o.c.
7	No. 4 at 10" o.c.	No. 4 at 10" o.c.	No. 4 at 10" o.c.	No. 4 at 10" o.c.	No. 4 at 10" o.c.	No. 4 at 10" o.c.	No. 4 at 10" o.c.	No. 4 at 10" o.c.	No. 4 at 10" o.c.	No. 5 at 10" o.c.	No.5 at 10" o.c.	No.5 at 10" o.c.
8	No. 4 at 10" o.c.	No. 4 at 10" o.c.	No. 4 at 10" o.c.	No. 5 at 10" o.c.	No. 5 at 10" o.c.	No. 5 at 10" o.c.	No. 5 at 10" o.c.	No. 5 at 10" o.c.	No. 5 at 10" o.c.	No. 5 at 10" o.c.	No.5 at 10" o.c.	No.5 at 10" o.c.
9	No. 4 at 10" o.c.	No. 5 at 10" o.c.	No. 5 at 10" o.c.	No. 5 at 10" o.c.	No. 5 at 10" o.c.	No. 5 at 10" o.c.	No. 5 at 10" o.c.	No. 5 at 10" o.c.	No. 5 at 10" o.c.	N/A	N/A	N/A
10	No. 5 at 10" o.c.	No. 5 at 10" o.c.	No. 5 at 10" o.c.	No. 5 at 10" o.c.	No. 5 at 10" o.c.	No. 5 at 10" o.c.	N/A	N/A	N/A	N/A	N/A	N/A

For **SI**: 1 inch = 25.4 mm, 1 foot = 304.8 mm, 1 psf/ft. = 47.8803 Pa/m.

¹Minimum compressive strength of concrete is 2,000 psi.

²Minimum yield strength of No. 4 bar is 40,000 psi and No. 5 bar is 60,000 psi.

³Reinforcing steel must be placed on the tension side of the wall, and the outer surface of the steel is covered by 1½-inch-thick (38 mm) concrete.

⁴Horizontal reinforcement is No. 4 at 10 inches on center.

⁵Walls to be anchored to all floors and roofs as specified in Section 1611 of the code. Walls shall be interconnected at corners by embedding and lapping the reinforcement as specified in Section 1912 of the code.

⁶The basement floor must be poured and the first floor in place prior to backfilling, or adequate temporary shoring must be installed.

N/A = Not available.

TABLE 8—SF10 RETAINING WALL—WALL UNRESTRAINED AT TOP^{1,2,3,4}

WALL HEIGHT (feet)	EQUIVALENT FLUID PRESSURE (lbs./ft. ² /ft.)											
	30	35	40	45	50	55	60	65	70	75	80	85
6	No. 4 at 10" o.c.	No. 4 at 10" o.c.	No. 4 at 10" o.c.	No. 5 at 10" o.c.	No. 5 at 10" o.c.	No. 5 at 10" o.c.	No. 5 at 10" o.c.	No. 5 at 10" o.c.	No. 5 at 10" o.c.	No. 5 at 10" o.c.	No. 5 at 10" o.c.	No. 5 at 10" o.c.
7	No. 5 at 10" o.c.	No. 5 at 10" o.c.	No. 5 at 10" o.c.	No. 5 at 10" o.c.	No. 5 at 10" o.c.	No. 5 at 10" o.c.	No. 5 at 10" o.c.	No.5 at 10" o.c.	N/A	N/A	N/A	N/A
8	No. 5 at 10" o.c.	No. 5 at 10" o.c.	No. 5 at 10" o.c.	No. 5 at 10" o.c.	No. 6 at 10" o.c.	N/A	N/A	N/A	N/A	N/A	N/A	N/A
9	No. 5 at 10" o.c.	No. 6 at 10" o.c.	N/A	N/A	N/A	N/A	N/A	N/A	N/A	N/A	N/A	N/A

For **SI**: 1 inch = 25.4 mm, 1 foot = 304.8 mm, 1 psf/ft. = 47.8803 Pa/m.

¹Minimum compressive strength of concrete is 2,000 psi.

²Minimum yield strength of No. 4 bar is 40,000 psi and Nos. 5 and 6 bars is 60,000 psi.

³Reinforcing steel placed near the edge of wall side facing the soil such that the outer surface of the steel is covered by 1½-inch-thick concrete.

⁴Horizontal reinforcement is No. 4 at 10 inches on center.

N/A = Not available.

STANDARD FORM SF 101040

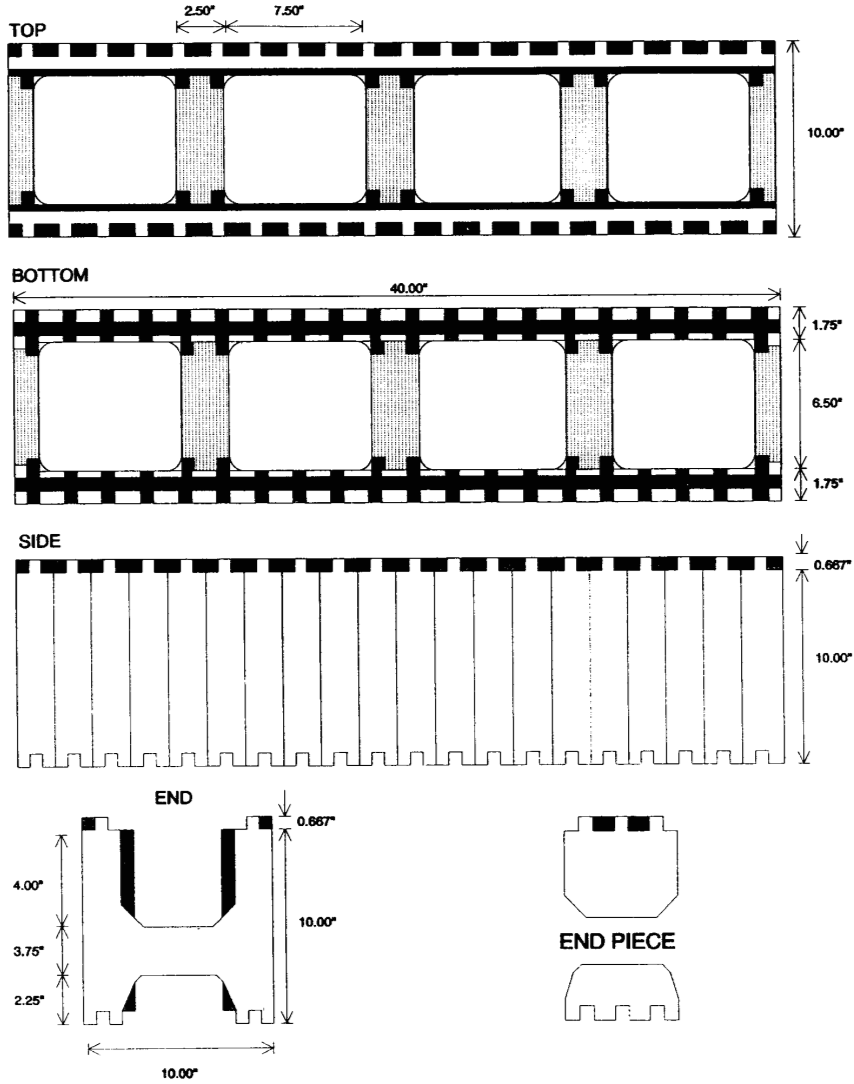

FIGURE 1—STANDARD FORM SF SERIES
 For SI: 1 inch = 25.4 mm, 1 foot = 304.8 mm.

VARIABLE WIDTH FORM VWF 21040

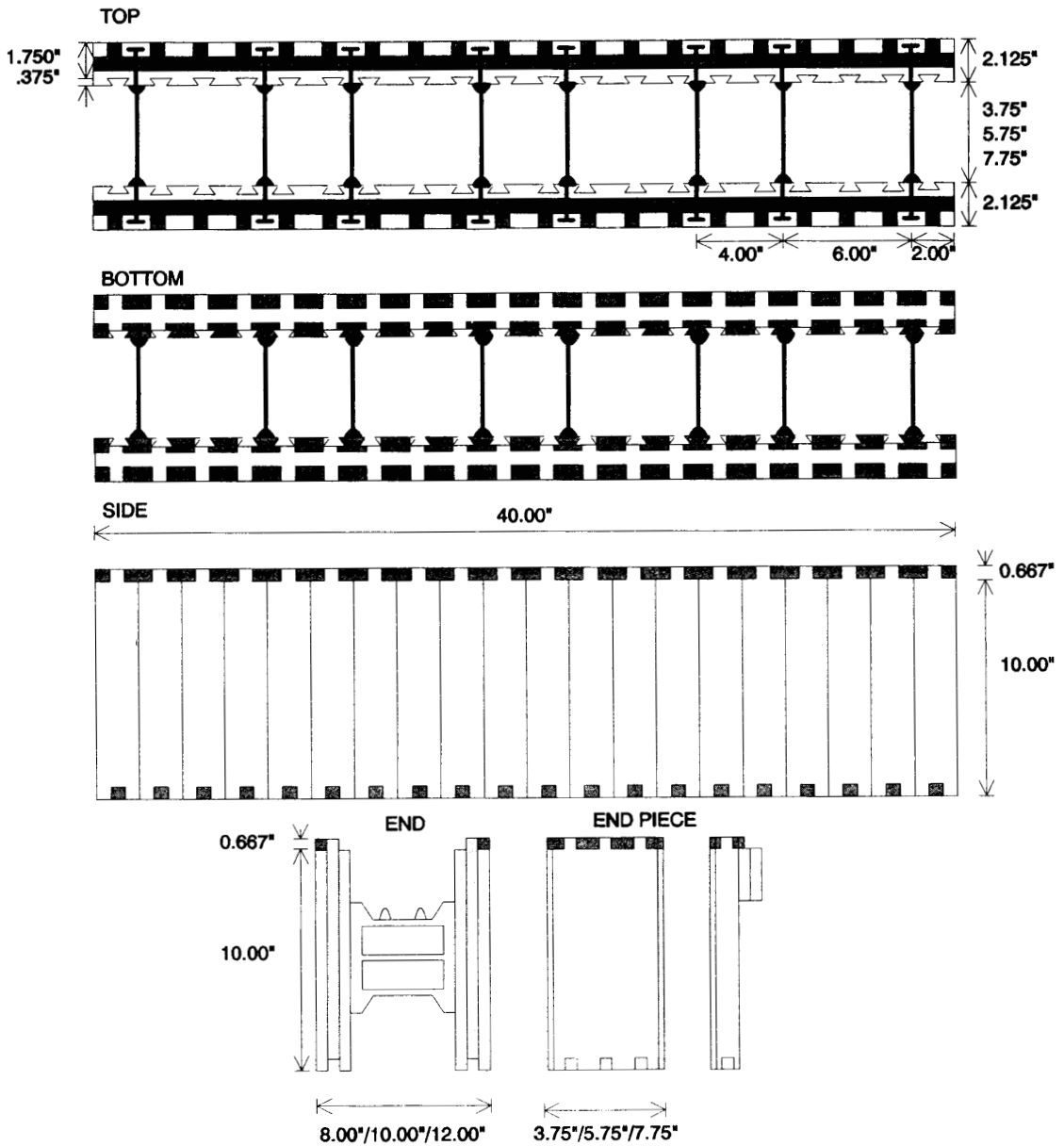

FIGURE 2—VARIABLE WIDTH 10VWF SERIES
 For SI: 1 inch = 25.4 mm, 1 foot = 304.8 mm.

VARIABLE WIDTH FORM VWF 21240

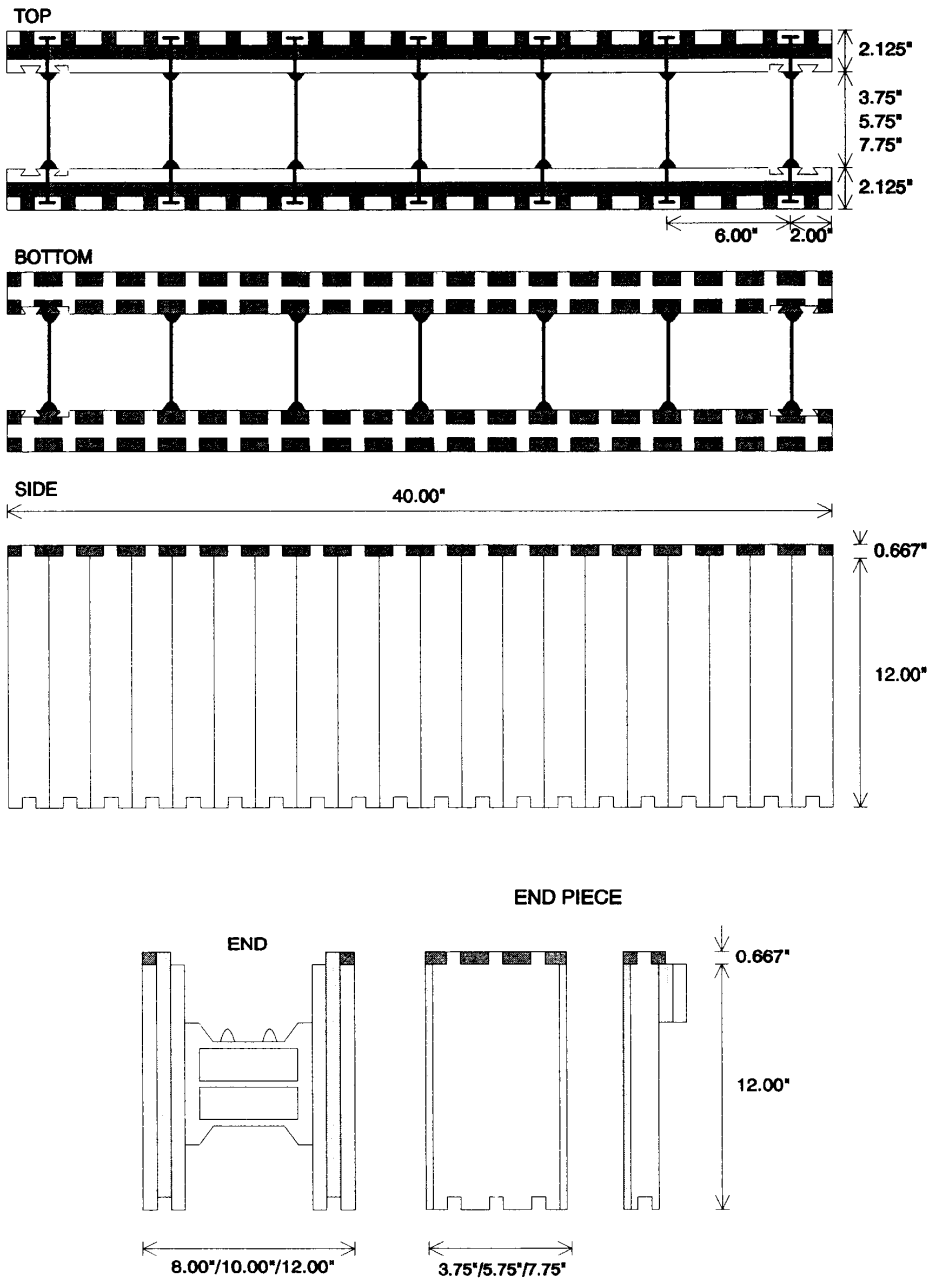
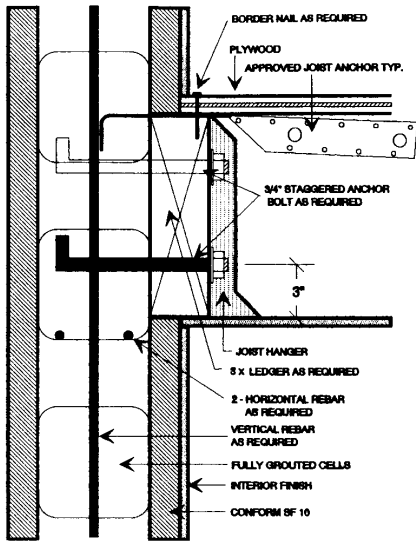
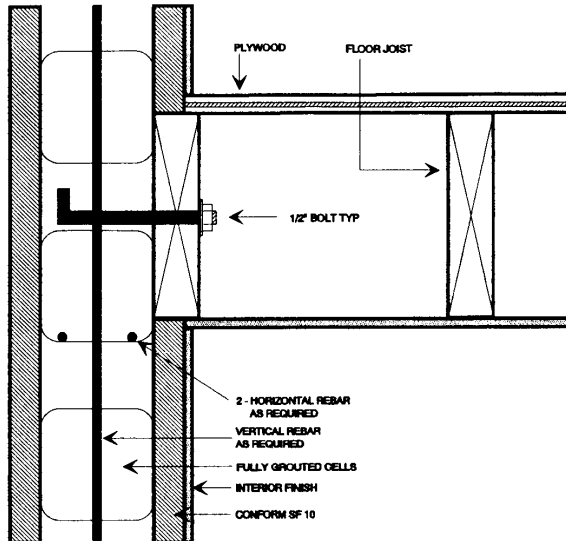

FIGURE 3—VARIABLE WIDTH 12VWF SERIES

For SI: 1 inch = 25.4 mm, 1 foot = 304.8 mm.



TYPICAL FLOOR FRAMING DETAIL
JOISTS PERPENDICULAR TO WALL



TYPICAL FLOOR FRAMING DETAIL
JOISTS PARALLEL TO WALL

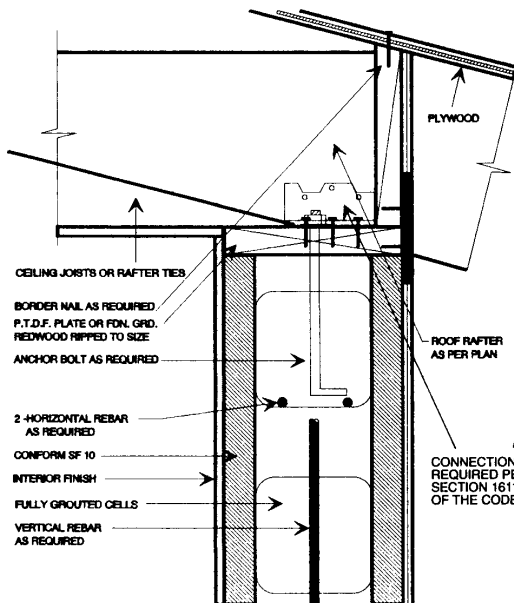

TYPICAL ROOF DETAIL
RAFTERS PERPENDICULAR TO WALL

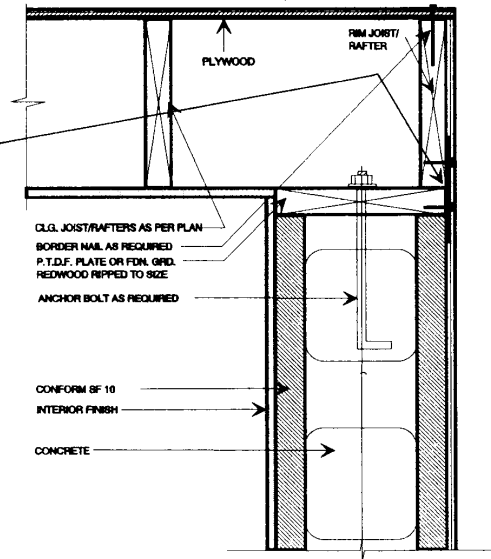

TYPICAL ROOF DETAIL
RAFTERS PARALLEL TO WALL

FIGURE 4—CONNECTIONS TO ROOFS AND FLOORS

For SI: 1 inch = 25.4 mm, 1 foot = 304.8 mm.

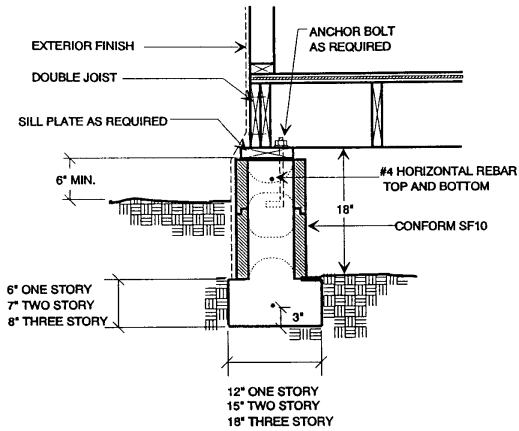

FIGURE 5—SF SERIES FOUNDATION WALL (STUD WALL CONSTRUCTION)

For SI: 1 inch = 25.4 mm, 1 foot = 304.8 mm.

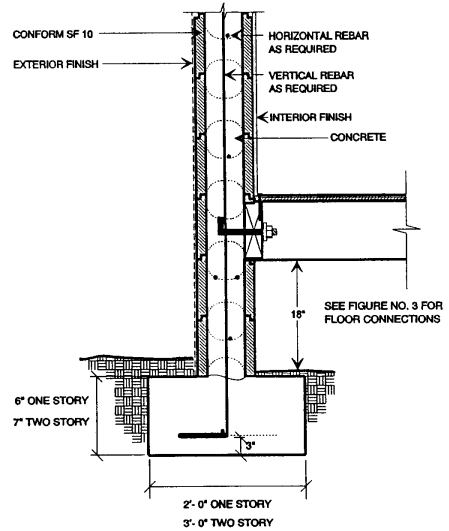

FIGURE 6—SF SERIES FOUNDATION WALL (CONCRETE WALL CONSTRUCTION)

For SI: 1 inch = 25.4 mm, 1 foot = 304.8 mm.

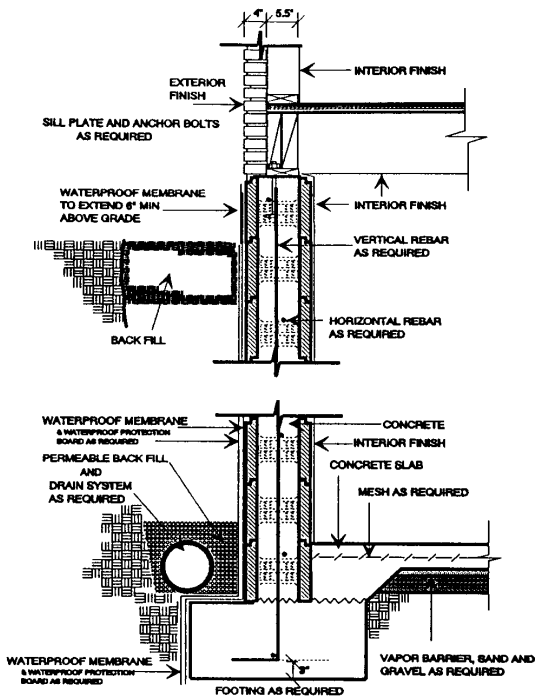

FIGURE 7—VWF SERIES BASEMENT WALL

For SI: 1 inch = 25.4 mm, 1 foot = 304.8 mm.

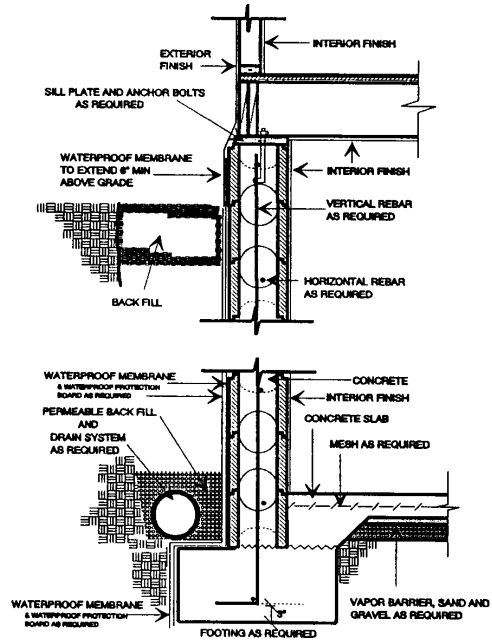
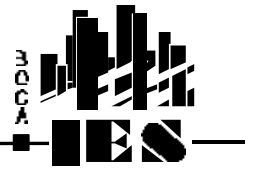

FIGURE 8—SF SERIES BASEMENT WALL

For SI: 1 inch = 25.4 mm, 1 foot = 304.8 mm.



evaluation scope

Compliance with the following codes:

BOCA National Building Code/1999

- # Section 106.4 Alternative materials and equipment
- # Section 1214.2 Air-Borne Noise
- # Section 1301.1 General
- # Section 1704.3 Labeling
- # Section 1909.1 Design of formwork
- # Section 2603.2 Labeling
- # Section 2603.3 Surface burning characteristics
- # Section 2603.4.1.4 Attics and crawl spaces

description

SmartBlock™ SF and VWF Forms are intended as permanent modular formwork for use in construction of plain and reinforced concrete walls and components including: grade beams, piers, step foundation walls, stem walls, retaining walls, basement walls, loadbearing and nonloadbearing interior walls, loadbearing and nonloadbearing exterior walls, sound barrier walls, fences, landscape walls, and exposed conditions within a crawl space.

The SF and VWF forms are modular blocks 40 inches (1 m) long, and 10²/₃ or 12³/₄ inches (273 to 324 mm) tall. Each block has two opposing faces of 2 pcf expanded polystyrene (EPS), 1³/₄ to 2¹/₈ inches (44 to 54 mm) thick. The void created by these faces is filled with concrete and required reinforcing steel. The EPS is manufactured from beads, which are manufactured by BASF Corporation (NER-479) and Huntsman Chemical Corporation (NER-384). The resulting minimum thickness of the concrete is 6¹/₂ inches (165 mm). See Figure 1 of this report.

The opposing faces of the VWF form units are connected with field-installed red (12 inch), blue (10 inch), or yellow (8 inch) polypropylene plastic ties, depending upon the nominal wall thickness being assembled. VWF form units are available in two models (21040 & 21240), which are identical except for the spacing of the plastic ties, as illustrated in Figures 2 and 3 of this report. Separate end pieces are used to close form ends. The resulting thickness of concrete is 7³/₄, 5³/₄ and 3³/₄ inches (197, 146 and 95 mm) respectively.

conditions of use

This report is limited to the applications and products as stated. BOCA-ES intends that the report be used by the code official to determine that the subject of the report complies with the code requirements specifically addressed, provided the product is installed in accordance with the following conditions:

- # American Conform Industries, Inc. shall provide the user of this report with complete instructions on the installation of SmartBlock™ SF and VWF. Where manufacturer's installation instructions differ from this report, this report shall be null and void. Information within the manufacturer's installation instructions that is not specifically evaluated herein is beyond the scope of this report.
- # SmartBlock™ SF and SmartBlock™ VWF shall be constructed to a maximum unfilled height of 10 feet. Maximum concrete pour rates shall be as indicated in Table 1 of this report.
- # Maximum size aggregate for the SmartBlock™ SF and VWF shall be 3/8 inch.
- # When the SmartBlock™ system is used to form exterior walls, the type of construction shall be limited to Type 5.

Exception: Installations complying with Section 2603.6.8 of the *BOCA National Building Code/1999*.

- # The SmartBlock™ SF and VWF shall be separated from the interior of the building by a thermal barrier of 1/2-inch gypsum board or equivalent approved material, attached in an approved manner, in accordance with Section 2603.4 of the *BOCA National Building Code/1999*.

Exception: On the interior side of crawl spaces, SmartBlock™ SF and VWF material does not require an ignition barrier, as required by Section 2603.4.1.4 of the *BOCA National Building Code/1999*, to separate it from the interior when all of the following conditions exist:

- ! Entry is made only for service of utilities;
- ! There are no interconnected spaces intended for human occupancy;
- ! The air in the crawl space or attic is not circulated to other parts of the building; and,

(Continued on next page)

DIVISION 03 CONCRETE

Section 03130 Permanent Forms

MANUFACTURER:

**American Conform
Industries, Inc.
1820 South Santa Fe
Santa Ana, CA 92705**

EVALUATION SUBJECT:

**SMARTBLOCK™ SF AND
VWF FORMS**

Research Report

95•46

PRINTED MARCH, 1999

Page 1 of 6

Copyright© 1999,
BOCA Evaluation Services, Inc.

A Participating Member
of the NES, Inc.

conditions of use*(Continued)*

- ! Additional thicknesses of foamed plastic are not installed over the exposed forms.
- # Use of SmartBlock™ SF and VWF has not been evaluated for use as a component of a fire-resistance rated assembly.
- # R-values of systems utilizing the SmartBlock™ SF and VWF shall be limited to those indicated in Table 2 of this report.
- # When SmartBlock™ is utilized to provide sound transmission control between dwelling units or between dwelling units and public or service areas in accordance with Section 1214.2 of the *BOCA National Building Code/1999*, the following shall apply:
 - ! The concrete formed by SmartBlock™ shall be minimum 6 in. thick;
 - ! Concrete density shall be 150 pcf, and shall fill the entire void within the SF unit; and
 - ! Minimum 1/2 inch thick of gypsum wallboard conforming to ASTM C36, shall be installed on each exterior face of the SF unit and caulked with nonhardening sealant at its entire perimeter.

items requiring verification

The following items are related to the use of the report subject, but are not within the scope of this evaluation. However, these items are related to the determination of code compliance:

- ⊞ Design calculations and details verifying the ability of the walls, formed by SmartBlock, to carry all superimposed loads placed upon them as required by Chapter 16 of the *BOCA National Building Code/1999*. These documents shall be prepared by an individual competent and qualified in the application of the structural design principles involved. The individual shall possess the registration of license in accordance with the professional registration laws of the state in which the project is constructed.
- ⊞ Compliance with the *BOCA National Building Code/1999*, and the American Concrete Institute's *Building Code Requirements for Structural Concrete*, 1995 (ACI 318-95), for concrete design and construction, including but not limited to the following:
 - ! Concrete consolidation. Vibration shall be used for consolidation only.
- ⊞ Special inspections in accordance with Section 1705.4 of the *BOCA National Building Code/1999*, to include, but not be limited to: concrete, reinforcing steel and formwork materials, installation of reinforcing steel, formwork installation and bracing, and concreting operations.
- ⊞ Weather-resistant covering, in accordance with Chapter 14 of the *BOCA National Building Code/1999*, when the SmartBlock™ SF and VWF are exposed to the exterior.
- ⊞ Waterproofing or dampproofing in accordance with Section 1813.0 of the *BOCA National Building Code/1999*, and the application of materials to SmartBlock™ including, but not limited to the following:
 - ! Compatibility of applied materials with the EPS. The EPS is not compatible with organic solvents such as hydrocarbons, chlorinated hydrocarbons, ketones and esters.
 - ! Use of coal tar pitch and emulsions is not permitted.
- ! Hot applications of materials shall not be in excess of 200 degrees F.
- ⊞ Installation method for the attachment of interior and exterior finishes.
- ⊞ Installations complying with Section 2603.6.8 of the *BOCA National Building Code/1999*, for buildings other than Type 5 construction.
- ⊞ Fireblocking in accordance with Section 721.0 of the *BOCA National Building Code/1999*. SmartBlock has not been evaluated as a fireblocking. Therefore, approved fireblocking shall be installed in place of SmartBlock at locations where fireblocking is required, such as but not limited to, ceiling and floor or roof levels in concealed wall spaces.
- ⊞ Method of rodent and insect infestation and penetration protection, for installations of the SmartBlock SF units that retain earth.

information submitted

- # Portland Cement Association Publication No. RD066, entitled *Sound Transmission Loss Through Concrete and Concrete Masonry Walls*, by Albert Litvin and Harold W. Belliston, dated 1978, containing results of testing of 6 in. and 8 in. plain concrete in accordance with ASTM E90.
- # Project No. 19-020-2, dated February 19, 1992, prepared by Edward L. Pack, P.E., containing results of an engineering analysis regarding the sound transmission characteristics of the SmartBlock system.
- # ITL, Inc., Report No. TR0746, dated March 24, 1992, prepared by R.A. Bouvier, containing results of hydrostatic burst testing.
- # Calculations, dated December 1, 1996, signed and sealed by Douglas J. Schoonover, P.E., containing calculations to determine allowable concrete flow rates. See Table 1 of this report for a summary of the results.
- # Southwest Research Institute Project No. 01-7522-405, dated June 1996, signed by Alex B. Wenzel, containing results of crawl space fire tests, which indicate that the contribution to fire and fire spread of the 2 pcf EPS material manufactured by Huntsman was less than that of R-11 fiberglass insulation, when applied to the foundation wall.
- # Southwest Research Institute Project No. 01-7788-205, dated February 1996, signed by Alex B. Wenzel, containing results of crawl space fire tests, which indicate that the contribution to fire and fire spread of the 2 pcf EPS material manufactured by BASF was less than that of R-11 fiberglass insulation, when applied to the foundation wall.
- # Report entitled, *Description of the R and U Value Determinations for a Test Wall, 70 1/20 x 79 3/40 x 97/80, Composed of (American) Conform's EPS Forms Filled with Concrete*, prepared by H.F. Poppendiek and R.J. Whaley of Geoscience Ltd., dated March 1992, reporting the R value of the SF form units in accordance with the procedures of ASTM C 236.

- # Calculations prepared by Thomas C. Campbell, P.E., dated March 11, 1992, establishing the R values for the three VWF wall systems based on *ASHRAE Fundamentals*, 1989, Chapter 22. See Table 2 of this report for a summary of the results.
- # Letter, dated December 3, 1996, by Douglas J. Schoonover, P.E., indicating that the testing performed in accordance with ASTM C 236, as listed above, was performed under his direct supervision, and that the material tested was representative of the SmartBlock product described in this report.
- # American ConForm Industries Standard Operation Procedures, dated July 1994, containing procedures for the manufacture of SmartBlock.
- # Underwriters Laboratories, File No. R13265, dated April 23, 1998, issued October 15, 1998, signed by representatives of AmericanConform and Underwriters Laboratories, containing procedures for in-house plant inspections and product labeling.

application for permit

To aid in the determination of compliance with this research report, the following represents the minimum level of information to accompany the application for permit:

- # The language “See BOCA Evaluation Services, Inc. Research Report No. 95-46” or a copy of this report;
- # Details, notes and calculations of concrete design and construction as required by the *BOCA National Building Code/1999* and ACI 318-95, prepared by a qualified individual as indicated in this report.

- # Concrete aggregate size and weight;
- # Air temperature at which the concrete is to be poured and rate of placement;
- # Unfilled height of the SmartBlock™ SF and VWF systems;
- # Details of steel reinforcement at openings with the Smart-Block™ SF and VWF systems;
- # Details of thermal barriers;
- # Details of interior and exterior finishes, when utilized; and
- # Details of waterproofing, dampproofing, and adhesive materials, when utilized.

identification

- # SmartBlock™ shall be marked at the plant with the identifying language “See BOCA Evaluation Services, Inc., Research Report No. 95-46.”
- # Additionally, each pallet of SmartBlock™ units shall be labelled with the authorized listing mark of the third-party inspection agency, Underwriters Laboratories (NER-QA403). The label shall indicate the product's identification and fire performance characteristics (flame spread and smoke-developed ratings).

**Table 1
ALLOWABLE CONCRETE POUR RATES (vertical feet/hour)**

Ambient Temperature (°F)	SmartBlock™ SF	SmartBlock™ VWF
40	1.5	2.5
50	2	3
60	2.5	4
70	3	4.5
80	3.5	5
90	4	6

Notes:

1. Concrete mixing and placement shall be in accordance with Section 1908 of the *BOCA National Building Code/1999*.
2. Concrete density shall be 150 pcf, and shall fill the entire void within the SF unit.

**Table 2
SMARTBLOCK™ R VALUES**

Form Type/Concrete Thickness	R Value (h•ft²•°F/Btu)
SmartBlock™ SF	17.5
SmartBlock™ VWF/3.75 in.	19.4
SmartBlock™ VWF/5.75 in.	19.5

SmartBlock™ VWF/7.75 in.	19.7
--------------------------	------

Notes:

1. Concrete mixing and placement shall be in accordance with Section 1908 of the *BOCA National Building Code/1999*.
2. Concrete density shall be 150 pcf, and shall fill the entire void within the SF unit.

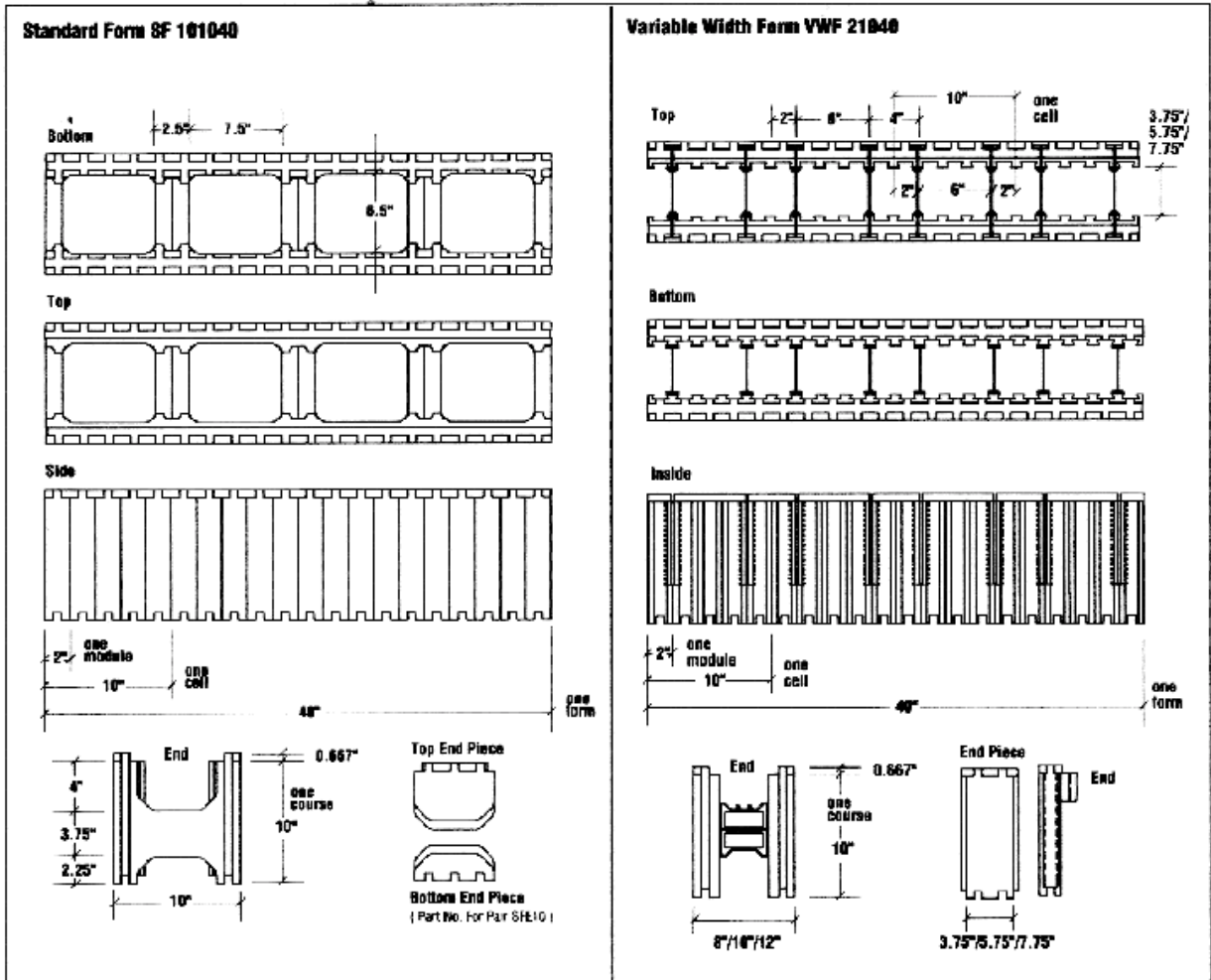

Figure 1*

Figure 2*

*THESE DRAWINGS ARE FOR ILLUSTRATION PURPOSES ONLY. THEY ARE NOT INTENDED FOR USE AS CONSTRUCTION DOCUMENTS FOR THE PURPOSE OF DESIGN, FABRICATION OR ERECTION.

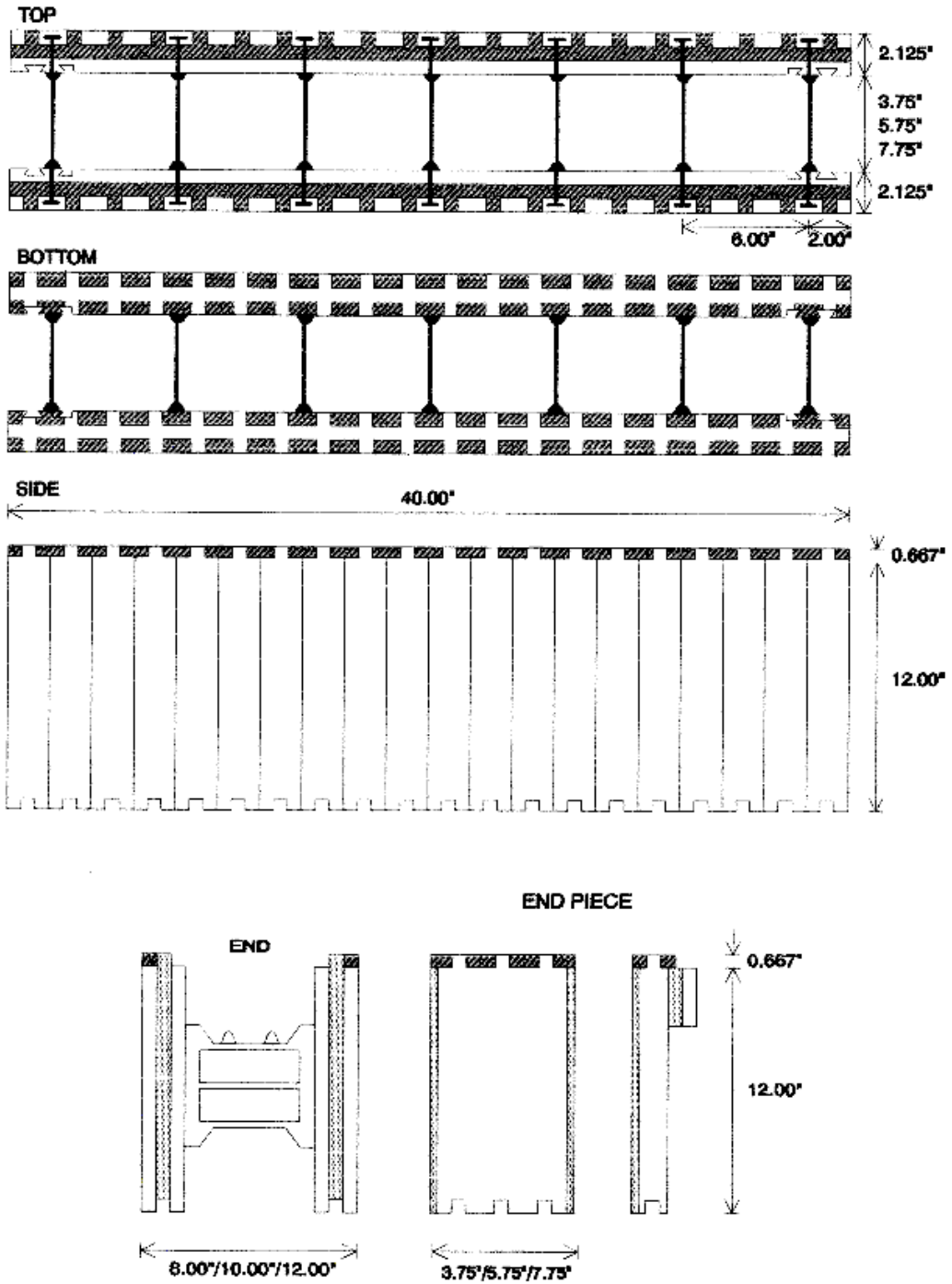

Figure 3*
Variable Width Form VWF 21240

NOTICE TO REPORT USERS

This report is subject to annual certification. Reports that are not certified shall not be used or referred to. To determine the status of certification of this report, contact BOCA Evaluation Services, Inc., or consult the latest edition of the *BOCA International Product Evaluation Listing* published periodically in the BOCA magazine.

This report is subject to the conditions listed herein and to the specific product, data and test reports submitted by the applicant requesting this report. Independent test were not performed by BOCA Evaluation Services, Inc. and BOCA-ES specifically does not make any warranty, either expressed or implied, as to any findings or other matter in this report or as to any product covered by this report. Evaluation reports are not to be construed as representing aesthetics or any other attributes not specifically addressed nor as an endorsement or recommendation for the use of the report subject. This disclaimer includes, but is not limited to, merchantability.

Please contact BOCA Evaluation Services, Inc., with any questions you may have regarding this report. Additionally, please contact us

4051 West Flossmoor Road • Country Club Hills, IL 60478-5795

telephone (708) 799-2305 • fax (708) 799-0310

e-mail: boca-es@bocai.org • <http://www.bocai.org>

if you have any information on the performance of the product described herein which is contrary to this report.



Approval #

980020-1
Replaces 920083-T

Safety & Buildings Division
201 West Washington Avenue
P.O. Box 2689
Madison, WI 53701-2689

Wisconsin Material Approval

Material

CONFORM EXPANDED POLYSTYRENE BLOCKS

Manufacturer

American Conform Industries, Inc.
1820 S. Santa Fe Street
Santa Ana, CA 92705

SCOPE OF EVALUATION

The Conform® Expanded Polystyrene Blocks manufactured by American Conform Industries, Inc. were evaluated in accordance with sections **ILHR 21.11, 21.11(1)(a), ILHR 51.06(2), ILHR 51.06(3)(a), ILHR 51.06(3)(b), and ILHR 51.06(5)(f)** of the Wisconsin Building and Heating, Ventilating and Air Conditioning Code.

DESCRIPTION AND USE

The Conform® concrete form system consists of expanded polystyrene (EPS) units of two basic types Standard Forms(SF Series) and Variable Width Forms (VWF Series) which serve as insulation and forms for load-bearing walls, shear walls and foundation walls. The two component units are described below:

1. The SF Series has a face shell thickness of 1 ¼ inches average. They are 10 inches high/10 inches wide by 40 inches long with tongue-and-groove attachments at the top and bottom. When laid up, the units form 7 ½ inch by 6 ½ inch rectangular vertical cores at 10 inches on center and 6 ½ inches by 6 ¼ inch rectangular horizontal cores at 10 inches on center. The form units remain after placing of reinforcing steel and concrete and must be protected by approved interior and exterior finish materials.

- The VWF Series has a face shell thickness of 2 inches average. The unites are 12 inches high by 40 inches long and have variable widths depending on the thickness of the finished concrete wall, which are 3 ¼ inches; 5 ¼ inches; 7 ¼ inches. The tongue-and-groove units are interconnected with seven polypropylene bridge inserts.

Conform® Blocks are made of molded expanded polystyrene (EPS). The EPS is BF322 or BF422, in densities of 1.5 – 2.0 pcf Styropor manufactured by BASF, or Types 254, 454, 554, 754, 900 and 4786, in densities of 1.5 – 2.0 pcf manufactured by Huntsman Chemical Corporation.

TEST RESULTS

A sample wall section of insulated reinforced concrete made with Conform® Blocks and Boards was tested in accordance with ASTM C236 standard by Geoscience LTD and found to have an R-value of:

$$R_{total} = R_{air\ to\ air} = 17.55\ hr^2\ ^\circ F / Btu\ and$$

$$U = 1 / R_{total} = 1 / 17.55 = 0.057\ Btu / hr\ ft^2\ ^\circ F\ with\ foam\ density\ of\ 1.9\ lbs / ft^3\ or\ higher.$$

Conform® Blocks were tested by Underwriters Laboratories, Inc. and the classification for BASF Type 322 or Type 422 beads and Huntsman Chemical Corporation Type 4786 polystyrene beads at a nominal 1.8 pcf density and 5-inch thick maximum as follows: smoke developed 250; flame spread 10.

Wall sections constructed with Conform® Expanded Polystyrene Blocks made with Huntsman foam only, covered by ½-inch gypsum board passed a room fire test conducted by the University of California, Berkeley.

Southwest Research Institute of San Antonio, Texas has authorized BASF's use of the SWRI Crawl Space Test Report #01-7788-205, and Huntsman Chemical Corporation's use of the SWRI Crawl Space Test Report #01-1374-206(1).

LIMITATIONS OF APPROVAL

The foam plastic substrate shall be listed as having a flame spread rating of 25 or less and a smoke developed rating of 450 or less when tested in accordance with ASTM E-84.

The exterior face of all walls must be finished with an approved weather covering.

Thermal barriers shall be provided to separate the forms from the occupied spaces in accordance with sections II.HR 21.11 and 51.06(3).

Conform® Expanded Polystyrene Blocks may remain uncovered on the interior of crawl space walls provided the floor between the crawl space and the occupied space consists of at least ½-inch tongue and groove plywood sheathing or equivalent, and the crawl space is not used for storage or air handling purposes.

Conform® Expanded Polystyrene Blocks are nonstructural building elements, their use is limited to that of an insulated concrete formwork only.

These forms are approved for use as concrete forms for basement walls and exterior walls when the resulting concrete walls satisfy **Table ILHR 21.18-A** or when structural calculations are submitted to the Department. The VWF6 Series and VWF8 Series blocks are considered as providing solid walls of polystyrene and concrete of 4 inch, 6-inch and 8-inch nominal thickness, respectively.

The Conform Expanded Polystyrene Blocks shall be installed in accordance with the manufacturer's recommendations.

This approval will be valid through December 31, 2002, unless manufacturing modifications are made to the product or a re-examination is deemed necessary by the department. The Wisconsin Material Approval Number must be provided when plans that include this product are submitted for review.

DISCLAIMER

The department is in no way endorsing or advertising this product. This approval addresses only the specified applications for the product and does not waive any code requirement not specified in this document.

Reviewed by: PM

Approval Date: 3-26-98

By: Lee E. Finley
Lee E. Finley, C.S.I.
Product/Material and Building Plan Review
Program Development Bureau
(414)548-8611

CITY OF LOS ANGELES
CALIFORNIA



RICHARD J. RIORDAN
MAYOR

COMMISSIONERS

JOYCE L. FOSTER
PRESIDENT

MABLE CHANG
VICE-PRESIDENT

LEE KANON ALPERT
JEANETTE APPLIGATE
NANCY H. ZAMORA

DEPARTMENT OF
BUILDING AND SAFETY

400 CITY HALL
LOS ANGELES, CA 90013-4880

Andrew Adelman
GENERAL MANAGER

RICHARD HOLGUIN
EXECUTIVE OFFICER

American Conform Industries, Inc.
1820 S. Santa Fe Street
Santa Ana, CA 92705

Attn: Ed Bobich
(714) 662-1100

RESEARCH REPORT: RR 25006
(CSI #03100)

BASED UPON ICBOES EVALUATION
REPORT NO. 4572

REEVALUATION DUE DATE:
August 1, 2001

GENERAL APPROVAL - Reevaluation - Conform Smartblock Polystyrene Forms for Reinforced Concrete Walls

DETAILS

Conform is a non-structural material used as forms for the placement of reinforced concrete. These forms remain in place after the concrete has cured and become part of the structure. The formwork is assembled by interlocking the forms (10" high x 40" long) one on top of the other in a running bond.

The above assemblies and/or products are approved when in compliance with the description, use, identification and findings of Report No. 4572, dated January, 1999, of the I.C.B.O. Evaluation Service, Incorporated. The report, in its entirety, is attached and made part of this general approval.

The parts of Report No. 4572 which are excluded on the attached copy have been removed by the Los Angeles Building Department as not being included in this approval.

The approval is subject to the following conditions:

1. Complete plans and calculations signed by a licensed engineer or architect registered in the State of California for concrete walls, including retaining walls and basement walls must be submitted to the Structural Plan Check Section for approval for each job.

Exception:

Footings using VWF forms and meeting the requirements of Table 18-I-D, or footing using the SF forms in compliance with figure number 4 of the attached ICBO evaluation report do not require calculations.

RR 25006
Page 1 of 2



American Conform Industries, Inc.

RE: Conform Smartblock Concrete Form Wall System

Exception:

Footings using VWF forms and meeting the requirements of Table 18-I-D, or footing using the SF forms in compliance with figure number 4 of the attached ICBO evaluation report do not require calculations.

2. The forms may only be used in locations where non-fire rated, combustible construction is permitted by the 1996 Los Angeles City Building Code.
3. The allowable pour rate of the forms shall be 2 ft. per hour for SR series forms, and 4 ft. per hour for VWF series forms.

The parts of Report No. 4572 which are excluded on the attached copy have been removed by the Los Angeles Building Department as not being included in this approval.

DISCUSSION

The omission of the retaining walls and basement walls from the ICBOES report does not preclude the use of the Conform products from said construction.

BASF Corporation Expanded Polystyrene Beads are approved by Research Report No. 24943.

This general approval will remain effective provided the Evaluation Report is maintained valid and unrevised with the issuing organization. Any revisions to the report must be submitted to this Department, with appropriate fee, for review in order to continue the approval of the revised report.

Addressee to whom this Research Report is issued is responsible for providing copies of it, complete with any attachments indicated, to architects, engineers and builders using items approved herein in design or construction which must be approved by Department of Building and Safety Engineers and Inspectors.

American Conform Industries, Inc.

RE: Conform Smartblock Concrete Form Wall System

2. The forms may only be used in locations where non-fire rated, combustible construction is permitted by the 1999 Los Angeles City Building Code.
3. The allowable pour rate of the forms shall be 4 ft. per hour for SF series forms, and 4 ft. per hour for VWF series forms.

DISCUSSION

The omission of the retaining walls and basement walls from the ICBOES report does not preclude the use of the Conform products from said construction.

BASF Corporation Expanded Polystyrene Beads are approved by Research Report No. 24943.

This general approval will remain effective provided the Evaluation Report is maintained valid and unrevised with the issuing organization. Any revisions to the report must be submitted to this Department, with appropriate fee, for review in order to continue the approval of the revised report.

Addressee to whom this Research Report is issued is responsible for providing copies of it, complete with any attachments indicated, to architects, engineers and builders using items approved herein in design or construction which must be approved by Department of Building and Safety Engineers and Inspectors.

This general approval of an equivalent alternate to the Code is only valid where an engineer and/or inspector of this Department has determined that all conditions of this approval have been met in the project in which it is to be used.

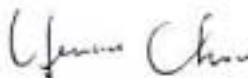

YEUAN CHOU, Chief
Engineering Research Section

DCR
DCR:am
RR25006-wgk/f
B-1-10-05
IC-2183D/1006.1

Attachment: ICBOES Evaluation Report No. 4572 (10 Pages).

TEXAS DEPARTMENT OF INSURANCE

Engineering Services / MC 103-3A 333 Guadalupe Street P.O. Box 149104 Austin, Texas 78714-9104
Phone No. (512) 322-2212 Fax No. (512) 463-6693

PRODUCT EVALUATION

FR-24

Effective December 12, 1995

Revised October 30, 1998

The following product has been evaluated for compliance with the wind loads specified in Section 120 of the Texas Department of Insurance Windstorm Resistant Construction Guide and Section 103 of the Texas Windstorm Insurance Association Building Code for Windstorm Resistant Construction. This product shall be subject to reevaluation 3 years after the effective date.

This product evaluation is not an endorsement of this product or a recommendation that this product be used. The Texas Department of Insurance has not authorized the use of any information contained in the product evaluation for advertising, or other commercial or promotional purpose.

This product evaluation is intended for use by those individuals who are following the prescriptive portions of the Texas Department of Insurance Windstorm Resistant Construction Guide or the Texas Windstorm Insurance Association Building Code for Windstorm Resistant Construction. This product evaluation does not relieve a Texas licensed engineer of his responsibilities as outlined in the Texas Engineering Practice Act.

Conform Smartblock Polystyrene Forms for Reinforced Concrete Walls, SF and VWF series, as manufactured by

**American ConForm Industries, Inc.
1820 South Santa Fe St.
Santa Ana, California 92705**

will be acceptable as permanent framework for structural concrete walls in designated catastrophe areas along the Texas Gulf Coast when constructed in accordance with the following product evaluation.

PRODUCT DESCRIPTION

Conform Smartblock formwork is non-structural expanded polystyrene (EPS) into which concrete and steel are placed to create a reinforced concrete structure. The interlocking forms are placed one on top of the other in a running bond and serve as forms for the reinforced concrete wall. Smartblock forms are manufactured in 10 inch standard form series and 10 and 12 inch variable-width form series. Both form series are 40 inches in length and 10 inches in height.

INSTALLATION REQUIREMENTS

General Installation Requirements:

Building plans and calculations, along with a WPI-2D, Building Design Compliance, form sealed by a Texas licensed professional engineer, shall be submitted to the Texas Department of Insurance before the commencement of construction. One set of blueprints and calculations, sealed by a Texas licensed professional engineer, shall be available on the job-site to the Windstorm Inspections staff at all times.

The design of the roof framing system shall either be specified on the design plans or shall be constructed in accordance with the applicable windstorm construction document adopted by the Texas Department of Insurance. The building plans shall specify the connection of the roof system to the wall system.

The design of the foundation and the connection of the wall system to the foundation shall be specified on the building plans.

Conform Smartblock formwork shall be covered with $\frac{1}{2}$ inch gypsum wallboard or other 15 minute thermal barrier to separate it from the interior of the building.

The attachment of the exterior wall coverings and roof coverings shall either be specified on the building plans or shall be specified in a Texas Department of Insurance product evaluation report. If a Texas Department of Insurance product evaluation report is used, then the evaluation report shall have a method for fastening to the wall and roof system.

Installation Requirements:

Inland II Zone: The wall system shall be designed to resist the wind pressures specified in Section 120 of the Texas Department of Insurance *Windstorm Resistant Construction Guide*. Use the "Inland" wind pressures specified in Figure 1. The design drawings shall include the design wind pressure (in psf) used to design the building system.

Inland I Zone: The wall system shall be designed to resist wind pressures determine using the wind load provisions of ASCE 7-93 *Minimum Design Loads for Buildings and Other Structures*. Section 102 of the Texas Windstorm Insurance Association *Building Code for Windstorm Resistant Construction* specifies the basic wind speed required for the design. The design drawings shall include the basic wind speed (in miles per hour) used to design the building system.

Seaward Zone: The wall system shall be designed to resist wind pressures determine using the wind load provisions of ASCE 7-93 *Minimum Design Loads for Buildings and Other Structures*. Section 102 of the Texas Windstorm Insurance Association *Building Code for Windstorm Resistant Construction* specifies the basic wind speed required for the design. The design drawings shall include the basic wind speed (in miles per hour) used to design the building system.

Note: The manufacturer's installation instructions and design drawings shall be available on the job site during installation. All fasteners shall be corrosion resistant as specified in either Texas Department of Insurance *Windstorm Resistant Construction Guide* or the Texas Windstorm Insurance Association *Building Code for Windstorm Resistant Construction* depending upon which document is applicable.

10.6 Structural Design Calculations for SF10 Series

ALLOWABLE AXIAL LOADS (POUNDS PER FOOT)

WALL HEIGHT (FEET)									
4'-0"	5'-0"	6'-0"	7'-0"	8'-0"	9'-0"	10'-0"	11'-0"	12'-0"	13'-0"
43,509	42,646	41,590	40,343	38,903	37,272	35,449	33,434	31,227	28,828

SF10 SERIES REBAR @ 10" ON CENTER - VERTICAL

VERTICAL REINFORCING STEEL	ALLOWABLE MOMENT $.9Asfy(d-a/2)$ (ft - lbs. / ft)	ALLOWABLE SHEAR $(.85)2\sqrt{f'_c}bd$ (lbs / ft)	a	d	WALL WEIGHT (PCF)
#4 CENTERED	2114	2223	.63	3.25	74.1
#4 ON EDGE	3194	3250	.63	4.75	74.1
#5 CENTERED	4219	2223	1.46	3.25	74.1
#5 ON EDGE	6625	3207	1.46	4.687 5	74.1
#6 CENTERED	-	-	-	-	-
#6 ON EDGE	7341	2822	2.07	4.125	74.1

$f'_c = 2,000$ psi

Horizontal reinforcing steel = #4 @ 10" on center

$f_y = 40,000$ psi for #3 and #4 reinforcing steel

$f_y = 60,000$ psi for #5 and larger reinforcing steel

ALLOWABLE AXIAL LOADING

$$fP = 0.55 f f_c A_y [1 - (Kl_c / 32 h)^2]$$

Where :

- f = 0.70
- f_c = 2000 psi
- A_g = 6.5 inches x 9 inches (reduced 25% due to the 2.5 inch
58.50 inches² wide bridges @ 10" on center)
- K = 0.80 - Restrained against rotation at the top and bottom
- h = 6.5 inches

Wall Height

$$4'-0'' \quad fP = (0.55)(.70)(2000)(58.50)[1 - (.80(48)/(32)(6.5))^2] = 43509 \text{ lbs/ft}$$

$$5'-0'' \quad fP = (0.55)(.70)(2000)(58.50)[1 - (.80(60)/(32)(6.5))^2] = 42646 \text{ lbs/ft}$$

$$6'-0'' \quad fP = (0.55)(.70)(2000)(58.50)[1 - (.80(72)/(32)(6.5))^2] = 41590 \text{ lbs/ft}$$

$$7'-0'' \quad fP = (0.55)(.70)(2000)(58.50)[1 - (.80(84)/(32)(6.5))^2] = 40343 \text{ lbs/ft}$$

$$8'-0'' \quad fP = (0.55)(.70)(2000)(58.50)[1 - (.80(96)/(32)(6.5))^2] = 38903 \text{ lbs/ft}$$

$$9'-0'' \quad fP = (0.55)(.70)(2000)(58.50)[1 - (.80(108)/(32)(6.5))^2] = 37272 \text{ lbs/ft}$$

$$10'-0'' \quad fP = (0.55)(.70)(2000)(58.50)[1 - (.80(120)/(32)(6.5))^2] = 35449 \text{ lbs/ft}$$

$$11'-0'' \quad fP = (0.55)(.70)(2000)(58.50)[1 - (.80(132)/(32)(6.5))^2] = 33434 \text{ lbs/ft}$$

$$12'-0'' \quad fP = (0.55)(.70)(2000)(58.50)[1 - (.80(144)/(32)(6.5))^2] = 31227 \text{ lbs/ft}$$

$$13'-0'' \quad fP = (0.55)(.70)(2000)(58.50)[1 - (.80(156)/(32)(6.5))^2] = 28828 \text{ lbs/ft}$$

SF10 SERIES

#4 @ 10" O.C. - CENTERED

$$f_y = 40,000 \text{ psi}$$

$$f_c = 2,000 \text{ psi}$$

$$A_s = 12/10 (.20) = 0.24 \text{ in}^2/\text{ft}$$

$$b = 9 \text{ inches (reduced 25% for bridge width)}$$

$$d = 6.5 \text{ inches} / 2 = 3.25 \text{ inches}$$

DESIGN MOMENT

$$a = A_s f_y / .85 f_c b = (0.24)40,000 / .85 (2000) 9 = 0.6275$$

$$fM_u = .9 A_s f_y (d - a/2)$$

$$fM_u = .9 (.24) 40,000 (3.25 - 0.6275 / 2)$$

$$fM_u = 25369.20 \text{ inch - pounds} = \underline{\underline{2114 \text{ ft - lbs}}}$$

DESIGN SHEAR

$$\underline{\underline{\phi V_u = .85 2\sqrt{f_c} (b)d = .85(2)\sqrt{2000}(9)3.25 = 2223\text{lbs}}}$$

SF10 SERIES

#4 @ 10" O.C. - ON EDGE

$$f_y = 40,000 \text{ psi}$$

$$f_c = 2,000 \text{ psi}$$

$$A_s = 12/10 (.20) = 0.24 \text{ in}^2/\text{ft}$$

$$b = 9 \text{ inches (reduced 25% for bridge width)}$$

$$d = 6.5 - (1.5 + .50/2) = 4.75 \text{ inches}$$

DESIGN MOMENT

$$a = A_s f_y / .85 f_c b = (0.24)40,000 / .85 (2000) 9 = 0.6275$$

$$fM_u = .9 A_s f_y (d - a/2)$$

$$fM_u = .9 (.24) 40,000 (4.75 - 0.6275 / 2)$$

$$fM_u = 38329.20 \text{ inch - pounds} = \underline{\underline{3194 \text{ ft - lbs}}}$$

DESIGN SHEAR

$$\underline{\underline{\phi V_u = .85 2\sqrt{f_c} (b)d = .85 (2)\sqrt{2000} (9)4.75 = 3250 \text{ lbs}}}$$

SF10 SERIES

#5 @ 10" O.C. - CENTERED

$$f_y = 60,000 \text{ psi}$$

$$f_c = 2,000 \text{ psi}$$

$$A_s = 12/10 (.31) = 0.372 \text{ in}^2/\text{ft}$$

$$b = 9 \text{ inches (reduced 25% for bridge width)}$$

$$d = 6.5 / 2 = 3.25 \text{ inches}$$

DESIGN MOMENT

$$a = A_s f_y / .85 f_c b = (0.37)60,000 / .85 (2000) 9 = 1.45882$$

$$fM_u = .9 A_s f_y (d - a/2)$$

$$fM_u = .9 (.372) 60,000 (3.25 - 1.45882 / 2)$$

$$fM_u = 50633 \text{ inch - pounds} = \underline{\underline{4219 \text{ ft - lbs}}}$$

DESIGN SHEAR

$$\underline{\underline{\phi V_u = .85 2 \sqrt{f_c} (b)d = .85 (2) \sqrt{2000} (9) 3.25 = 2223 \text{ lbs.}}}$$

SF10 SERIES

#5 @ 10" O.C. - ON EDGE

$$f_y = 60,000 \text{ psi}$$

$$f_c = 2,000 \text{ psi}$$

$$A_s = 12/10 (.31) = 0.372 \text{ in}^2/\text{ft}$$

$$b = 9 \text{ inches (reduced 25% for bridge width)}$$

$$d = 6.5 - (1.5 + .625/2) = 4.6875 \text{ inches}$$

DESIGN MOMENT

$$a = A_s f_y / .85 f_c b = (0.372)60,000 / .85 (2000) 9 = 1.4588$$

$$fM_u = .9 A_s f_y (d - a/2)$$

$$fM_u = .9 (.372) 60,000 (4.6875 - 1.4588 / 2)$$

$$fM_u = 79510.08 \text{ inch - pounds} = \underline{\underline{6625 \text{ ft - lbs}}}$$

DESIGN SHEAR

$$\underline{\underline{\phi V_u = .85 2 \sqrt{f_c} (b) d = .85 (2) \sqrt{2000} (9) 4.6875 = 3207 \text{ lbs.}}}$$

SF10 SERIES

#6 @ 10" O.C. - ON EDGE

$$f_y = 60,000 \text{ psi}$$

$$f_c = 2,000 \text{ psi}$$

$$A_s = 12/10 (.44) = 0.528 \text{ in}^2/\text{ft}$$

$$b = 9 \text{ inches (reduced 25% for bridge width)}$$

$$d = 6.5 - (2.0 + .75/2) = 4.1250 \text{ inches}$$

DESIGN MOMENT

$$a = A_s f_y / .85 f_c b = (0.528)60,000 / .85 (2000) 9 = 2.0706$$

$$fM_u = .9 A_s f_y (d - a/2)$$

$$fM_u = .9 (.528) 60,000 (4.125 - 2.0706 / 2)$$

$$fM_u = 88093 \text{ inch - pounds} = \underline{\underline{7341 \text{ ft - lbs}}}$$

DESIGN SHEAR

$$\underline{\underline{\phi V_u = .85 2 \sqrt{f_c} (b) d = .85 (2) \sqrt{2000} (9) 4.125 = 2822 \text{ lbs.}}}$$

10.7 CSI TECHNICAL SPECIFICATIONS

This document is arranged in agreement with the recommended section and page format developed by CSI (Construction Specifications Institute). All versions of this document are copyrighted by American ConForm Industries and may not be used or duplicated without permission.

SECTION 03135

EXPANDED POLYSTYRENE CONCRETE FORMWORK

PART 1 GENERAL

1.01 SECTION INCLUDES

- A. American ConForm Industries SmartBlock for cast-in-place insulated concrete, with shoring, bracing and anchorage.
- B. Required access for other work.
- C. Form accessories.

1.02 INSTALLED BUT NOT FURNISHED PRODUCTS

- D. Section 03300: Cast-In-Place Concrete: Supply of concrete accessories for placement by this section.
- E. Section 04300: Supply of masonry accessories for placement by this section.
- F. Section 05500: Metal Fabrications: Supply of metal fabrications for placement by this section.

1.03 RELATED SECTIONS

- A. Section 03200: Concrete Reinforcement.
- B. Section 03300: Cast-In-Place Concrete.

1.04 REFERENCES

- C. ACI 301: Structural Concrete for Buildings.
- D. ACI 318: Building Code Requirements for Reinforced Concrete.
- E. ASTM C 578: Standard Specification for Preformed, Cellular Polystyrene Thermal Insulation.
- F. American ConForm Industries User's Manual for SmartBlock Forms.
- G. Structural Calculations for SmartBlock Forms.

1.05 DESIGN REQUIREMENTS

- A. A. All designing, engineering and construction of formwork, shoring and bracing must conform to design and applicable code requirements. Concrete must conform to required shape, lines and dimensions.

1.06 SUBMITTALS

- A. Shop Drawings; identify required dimensions, materials, and arrangement.
- B. Product Data; denotes form materials and installation requirements.

1.07 QUALITY ASSURANCE

- A. Work is to conform to ACI 347.
- B. Erection of formwork is the contractor's responsibility. Approval of the shop drawings, by the architect of record, as submitted or as corrected does not relieve the contractor of their responsibility to appropriately construct and maintain the forms so that they will function properly.

1.08 REGULATORY REQUIREMENTS

- A. Conform to applicable codes for designing, fabricating and erecting of formwork.

- B. ICBO Evaluation Service, Inc. Report 4572; ConForm SmartBlock Polystyrene forms for reinforced concrete walls.
- C. BOCA International Evaluation Services, Inc. Report 95- 46: DIVISION 03, CONCRETE; Section 03130 Permanent Forms.

1.09 DELIVERY, STORAGE, AND HANDLING

- A. Deliver American ConForm Industries SmartBlock Forms, installation instructions and user reference manual as provided by manufacturer.
- B. Store as strapped, banded or other prepackaged bundles and boxes provided by the manufacturer to prevent damage. Protect from UV deterioration due to prolonged exposure to direct sunlight.

1.10 COORDINATION

- A. Coordination of this section, with other sections requiring attachment or embedment of components or modification of formwork, must be prearranged.
- B. If erection of the formwork results in insufficient concrete cover over reinforcement, stop construction and request instructions from the Architect/Engineer of record.

PART 2 PRODUCTS

2.01 MANUFACTURERS: PREFABRICATED FORMS

- A. American ConForm Industries; Product: SmartBlock SF10 Standard Form.
- B. Two opposing faces of EPS foam connected with an EPS foam bridge. An interlocking tongue-and-groove is along top and bottom horizontal surfaces. Surface of exterior is scored 1/16" deep on 2" increments to facilitate measuring and cutting.
- C. Expanded Polystyrene Foam:

1. Density: 1.5 – 2.0 pcf.
2. Flame spread: ASTM E 84, 25 or less.
3. Smoke Developed: ASTM E 84, 450 or less.
- D. Substitutions: Under provisions of Section 01600.

2.02 MANUFACTURERS: UNASSEMBLED FORMS

- A. American ConForm Industries; Product: SmartBlock 12VWF Variable Width Form.
- B. Two opposing faces of EPS foam connected with polypropylene connectors manually inserted into preformed “T” slots in the foam. Connector flange is 1 ¼” wide by 6” long and after proper positioning, is ¼” below the surface of the foam panel. An interlocking tongue-and-groove is along top and bottom horizontal surfaces. Surface of exterior is scored 1/16” deep on 2” increments to facilitate measuring and cutting.
- C. Expanded Polystyrene Foam:
 1. Density: 1.5 – 2.0 pcf.
 2. Flame spread: ASTM E 84, 25 or less.
 3. Smoke Developed: ASTM E 84, 450 or less.
- D. Substitutions: Under provisions of Section 01600.

2.03 ACCESSORIES

- A. Bracing: Commercially available systems or nominal lumber or steel framing members.
- B. Cleat or Sleepers: Nominal lumber or steel framing members.
- C. Tape: Release tape for securing, protecting and sealing slots, corners, adjustment cuts, interlocking tongue and groove.
- D. Nails, Tie Wire, Lag Bolts, Through Bolts, Anchorages: Sized as required, of sufficient strength and composition to maintain formwork positioning while placing concrete.

PART 3 EXECUTION

3.01 EXAMINATION

- A. Dimensional lines, levels and centers of foundation must be verified before erecting formwork. Dimensions must agree with drawings.
- B. Strength of foundation concrete to be verified before proceeding with erecting formwork.

3.02 ERECTION: FORMWORK

- A. American ConForm Industries SmartBlock Forms must be installed in accordance with manufacturer's recommendations. Erect SmartBlock forms in a running bond. Corners are overlapped "log cabin" style. Protect forms and connectors from damage.
- B. Erect formwork, shoring and bracing to achieve design requirements. All work must conform to ACI 301 requirements.
- C. Bracing and shoring must ensure stability of formwork and support construction loads.
- D. Design, erect, support, brace, and maintain formwork to support axial, lateral, dynamic and static loads and moments that may occur until such forces can be resisted by the concrete structure. Resultant concrete, members and structures must be of correct shape, size, position, elevation and alignment.
- E. Plumb and align all joints.
- F. Approval of the Architect/Engineer of record must be obtained before framing openings not indicated on drawings.

3.03 EMBEDDED PARTS, OPENINGS AND INSERTS.

- A. Locate, set in place and stabilize items to be cast directly into concrete.
- B. Openings, where required, must be formed and stabilized.

- C. Work with other sections must be coordinated before locating, forming, placing and stabilizing openings, sleeves, slots, pockets, recesses, bolts, anchors, other inserts and components.
- D. Positioning of items must conform to the appropriate section. Masonry anchors must conform to spacing and intervals specified in Section 04300.
- E. Manufactures instructions for installation of accessories must be followed. Positioning must not be compromised during placement of the concrete.

3.04 FORM MAINTENANCE

- A. Remove foreign matter on exterior and interior of forms before placing into position.
- B. Cavities must be clear of debris prior to concrete placement.
- C. Compressed air or water can be used to remove remaining foreign matter. Ensure clean-outs allow water and debris can drain to exterior.
- D. In cold weather, remove ice and snow from interior cavity of forms. Do not use de-icing salts or other chemicals. Unless formwork is within heated space, do not use water to clean out forms. Use compressed air or other method approved by the Architect/Engineer of record to remove foreign matter.
- E. Wall finishes requiring bonding to the EPS foam can only be applied to a clean surface. Oxidation, from UV exposure, in the form of yellow dust must be removed from the exterior surfaces. Mild detergent and a stiff brush or pressure washers may be used. Rinse thoroughly with water.

3.05 TOLERANCES OF FORMWORK

- A. Tolerances of formwork must be maintained in accordance with ACI 301.

3.06 FIELD QUALITY ASSURANCE

- A. Before placement of concrete, inspect erected formwork, shoring, and bracing. Ensure formwork conforms to design, stability and cleanliness and that shoring, bracing, supports, fastenings, ties, accessories and other items are secure and maintain their positions.

END OF SECTION

