



DATA SHEETS

No: PCS-001

ProCleanSorb Loose Fill Product
(Applies to all manufactured product fill)

ZENOVA Multipurpose Fire Extinguishers
500, 2L, 6L & 9L

DEPLOYMENT INFORMATION: PROCLEANSORB

- PCS-001 is loose Premium ProCleanSorb
- It can be used to clear up spills of contaminants
- Shovel or scatter the loose fill over the spill
- Work in with a broom or brush until spill is completely absorbed
- Dispose of used ProCleanSorb in a blue hazardous waste sack
- Every 1Kg will absorb up to 12 times its weight of contaminants
- Will not absorb water
- Non-Leaching
- See Absorption list of contaminants for further details

DEPLOYMENT INFORMATION: ZENOVA MULTIPURPOSE FIRE EXTINGUISHERS

- Multipurpose fire extinguishers may be used on almost any type of fire
- Tested & Effective On A, B, F, Electrical & Lithium fires
- Independently tested to BS6165 for A, B & F class fires and safe to use on electrical equipment
- The perfect solution for fires in any environment from home to work and industry
- Easy to operate
- Safe to use around electrical equipment
- FX500 is operational from any angle
- Independently tested to BS6165 for A, B & F class fires
- The fluid used in the extinguisher has been tested and certified to EN1568 and EN3-7

PROCLEANSORB ABSORPTION & ENCAPSULATION

ACETONE	CYCLOHEXANE	MOTOR OILS
ACETONECYANHYDRIN	CYANIDE WASH	NAPHTHALENE
ACETONITRILE	DICHLOROBENZENE	2 - NITROANILINES
ACROLEIN	1, 2 DICLOROETHENE	NITROBENZENE
ADBLUE	DIESEL OILS	PAINTS
ALCOHOLS	DIESEL FUELS	PARRAFINS
ALLYLCHLORIDE	DYES	PENTANE
AMYLACETATES	ETHANOL	PENTACHLOROPHENOL
ANIMAL FATS	ETHEL BENZENE	PEANUT OIL
ANTI-FOULING	ETHELETER	PETROL
ANTI FREEZE	ETHELENE GLYCOL	PETROLEUM ETHER
AVGAS	EXANE (97%)	PRINTERS INKS
BENZINE	FISH OIL	PROPANOL
BIODEGRADEABLE OILS	GASOLINE	PHENOL
BODY FLUIDS	HEAVY METALS	PHENOL (48% IN ACETONE)
BROMODICHLOREMEMETHA	HEPTANES	SCINTILLATION LIQUID
BROMOFORM	HERBICIDES	SILICONE OIL (100CS)
BROMOFORM METHYL	HEXANES	STRENE
BUNKER C OIL	HEXACHLOROBENZENE	SULPHURIC ACID
BUTANOL	HEXACHOLOROBUTADIENE	TETRACHLOROETHANE
2 - BUTANONE	HEXACHLOROETHANE	TETRACHLOROETHYLENE
BUTYLACETATES	HF ACID	TETRAHYDROFURAN
BUTRIC ACID	INKS (OIL BASED)	TOLUENE
CANOLA OIL	ISOBUTANOL	TRICHLOROETHYLENE
CARBON DISULFIDE	ISOPRENE	TRICHLOROPHENOL
CARBON TETRACHLORIDE	ISOPROPANOL	TRIETHYLAMINE
CAUSTIC SODA	JET FUELS	VARNISHES
CHLOROBENZENE	JP/7	VAROL
CHLOROFORM	KEROSENE	VEGETABLE OIL
CLEANING FLUIDS	METHANOL	VINYL ACETATE
CORN OIL	METHYLENE CHLORIDE	VINYL CHLORIDE
CRUDE OILS	METHYL KEYTONE	XYLENE
CUTTING OILS	METHYL PHENOL	

ProCleanSorb also adsorbs heavy metals, including:

CADMIUM CHROMIUM COPPER LEAD NICKEL ZINC

Page: 01/06 – DATA SHEET PROCLEANSORB

Section 01: Chemical Product and Company Information

Supplier Details:

Pro Earth Limited
 Unit D3, Dominion Way, Rustington
 West Sussex
 United Kingdom

Contacts:

Tel: +44 (0)330-118-0336
 E-mail: enquiries@pro-earth.co.uk
 Web: www.pro-earth.co.uk

Manufacturer:

Pro Earth Ltd

Product Name: Premium **ProCleanSorb**
 Chemical Name: Canadian Sphagnum Peat Moss 100%
 Formula: Preparation / Mixture
 Product Use: ProCleanSorb is composed of fine screened dehydrated sphagnum peat moss, carefully selected, dried, sieved, blended pH balanced, using unique proprietary methods, in which its chemical and physical characteristics allow a very high capacity of moisture retention (or absorption) such as: fuels and fumes, hydrocarbons, solvents bodily fluids and the majority of chemical liquid products.

Section 02: Hazards Identification

Regulation Number: 1272/2008

GHS Hazard Class: Not Applicable

Signal Word:

Hazard Statement:

Precautionary Statements: Prevention No Precautionary Statement
 Response No Precautionary Statement
 Storage No Precautionary Statement
 Disposal No Precautionary Statement

<0% of mixture consists of ingredients of unknown acute toxicity

Hazardous Classification: Not classified as hazardous

Fire and Explosion: Not considered flammable or combustible, but product will burn if involved in a fire.

Potential Health Effects: No Information

Ingestion: No Information

Inhalation: Inhalation over long periods, of high amounts of nuisance dust may overload lung clearance mechanism, irritate mucous membrane and make lungs more vulnerable to respiratory disease.

Skin Contact: May cause slight irritation

Eye Contact: Eye irritation may result

Other: None

Chronic effects of over exposure: None

Appearance: Brownish, fibrous material.

Component	Health (Blue)	Flammability (Red)	Reactivity (Yellow)	Special (White)
ProCSorb	1	0	0	--

SAFETY DATA SHEET: ProCleanSorb Loose Fill Product (applies to all manufactured product
DATE: fill) Prepared: 04.12.2023

Section 03: Composition, Information on Ingredients

Product Composition	Approx. %	ACGIH TVL	OSHA PEL	NIOSH REL	CAS NO.	EINECS / ELINCS	DANGER SYMBOL	RISK PHRASE	DSL CANADA
Peat Moss	100	5mg / m ³ Respirable dust 10mg / m ³ Total dust	5mg / m ³ Respirable dust 15mg / m ³ Total dust	10mg / m ³ Total dust	-	-	-	-	-

S.M.E. Nutrient Analyses: results in ppm (mg/L)

N-NO ³	N-NH ₄ D	PD	K	Ca	Mg	Na	Zn	Mn	Cu	Fe	B
0-21	2-13	0-16	0-33	0-32	0-22	0-30	>0.3	>0.3	>0.05	>1.1	>0.2

Trade Secret (TS) Some items on this MSDS may be designated as trade secrets. Bon-a-fide requests for disclosure of trade secret information to medical personnel must be made in accordance with provisions contained in 29 CFR 1910.1200 I 1-13. The full text for all R-Phrases is shown in section 16.

Section 04: First Aid Measures

Inhalation: Remove to fresh air. If not breathing, provide CPR (cardio pulmonary resuscitation). Get immediate medical attention.

Skin Contact: Wash skin with plenty of soap and water for at least 15 minutes.

Eye Contact: Immediately wash skin with plenty of soap and water for at least 15 minutes. Get immediate medical attention if irritation persists.

Ingestion: If swallowed do NOT induce vomiting, give large quantities of water to drink. Never give anything to an unconscious person. Give immediate medical attention.

Section 05: Fire – fighting Measures

Flash Point: Not Applicable

Flammable Limits in Air: Not Applicable

Extinguishing Media: Water, Fog, Spray

Special Firefighting Procedures: Burning may continue inside bags, other containment media or loose product piles after surface fire has been extinguished. Break bags. Other containment media open or separate piles to ensure that fire is completely extinguished.

Section 06: Accidental Release Measures

Action to be taken if material is released or spilled:

Wear appropriate protective clothing as specified in section 08: Exposure Controls / Personal Protection.

Warn others of Spill and its nature

Contain Spill

Absorb Spill

Place in Chemical waste container

Disposal Method: Disposal should be in accordance with Local Authority / chosen waste carrier / waste assessment criteria (WAC).

Section 07: Handling and Storage

Precautions to be taken in Handling and storage: Wear proper personal protective equipment (PPE), avoid contact with skin, eyes or clothing. Wash hands after handling material. Follow the local applicable regulations for handling and storage.

Information on emptied container: Not Applicable

Specific Uses: ProCleanSorb is composed of fine screened sphagnum peat moss, carefully selected, dried, sieved, blended pH balanced, using ProCleanSorb unique proprietary methods, in which its chemical and physical characteristics allow a very high capacity of moisture retention (or absorption) such as: fuels and fumes, hydrocarbons, solvents and the majority of chemical liquid products.

Section 08: Exposure Controls / Personal Protection for Toxic Spill Clear Up

Ventilation:	Always provide good, general ventilation to minimise dust exposure when handling ProCleanSorb.
Respiratory Protection:	Always use approved face mask when deploying ProCleanSorb.
Protection Gloves:	Always use approved industrial grade gloves or gauntlets when handling ProCleanSorb.
Eye Protection:	Always use protective eyewear (Safety Glasses) when handling ProCleanSorb.
Protective Clothing:	Always wear suitable protective clothing to prevent skin contact.
Other Equipment:	Always ensure that hand washing equipment is available in the workplace.
Work / Hygiene Practices:	Avoid contact with eyes. Wash hand after handling.

SATURATION: **ALWAYS DETERMINE THE NATURE (COMPOSITION) OF THE SPILL TO BE ABSORBED. REFER TO PROCLEANSORB ABSORPTION LEVEL INFORMATION CHART REFER TO PROCLEANSORB CHEMICALS ABSORPTION CHART NEVER IMPLIMENT A SPILL CONTROL PROCEDURE WITHOUT IDENTIFYING THE ORIGIN OF THE SPILL AND ENSURING PERSONAL PROTECTION IS IN PLACE.**

Page: 04/06

Section 09: Physical and Chemical Properties

Appearance – Colour:	Brownish, fibrous material
Physical State:	Partially decomposed vegetation material
Odour:	Earthy

	Product Criteria
Odour Threshold	Earthy
PH	3.5 – 4.5
Flashpoint	150°C Minimum (Open cup)
Lower / Upper Explosive Limit	Not Applicable
Flammability (Solid / Gas)	Not Applicable
Explosive Properties	Not Applicable
Oxidising Properties	Not Applicable
Specific Gravity (@25°C)	60-90g/l (on dry weight basis)
Evaporation Rate	Not Applicable
% Volatile by Volume	Not Applicable
Partition Coefficient	Not Applicable
Auto Ignition Temperature	Not Applicable
Decomposition Temperature	Not Applicable
Boiling Point	Not Applicable
Melting Point	Not Applicable
Vapour Pressure	Not Applicable
Vapour Density	Not Applicable
Solubility in Water	None
Water Solubility in Solvent	None
Freezing Point	Not Applicable
Viscosity	Not Applicable
VOC Content	Not Applicable

PHYSICAL CHARACTERISTICS

Air Porosity:	10-20% (V/V)
Dry Bulk Density:	4-9 lbs/ft ³ (0.08 – 0.12gm/cm)
Moisture Content:	0 – 15% by weight
Water Holding Capacity:	63 – 73% by volume

Section 10: Stability and Reactivity

Stability:	Stable
Conditions to avoid:	None
Incompatibility (Materials to avoid):	None
Hazardous Decomposition Products:	None
Hazardous Polymerisation:	Will not occur

Section 11: Toxicological Information

GHS Required Criteria	Toxicity Criteria	Toxicity Information	Comments	Chemical
Acute Toxicity		No Information Available		
Skin Corrosion / Irritation		No Information Available		
Serious Eye Damage / Eye Irritation		No Information Available		
Respiratory or Skin Sensitisation		No Information Available		
Germ Cell Mutagenicity		No Information Available		
Carcinogenicity		Not Listed		
Reproductive Toxicity		No Information Available		
STOST – Single Exposure		No Information Available		
STOST – Repeated Exposure		No Information Available		
Aspiration Hazard		No Information Available		

STOST – Specific Target Organ Systemic Toxicity.

Only selected Registry of Toxic Effects of Chemical Substances (RTECS) data is presented here. See entry in RECTS.

Section 12: Ecological Information

Biodegradation: No Information Available
Bioaccumulation: No Information Available
Eco Toxicity: No Information Available
Mobility: No Information Available

Section 13: Disposal Considerations

Waste from residues / Unused products: Follow the waste disposal requirements of your Country, State or Local Authority

Packaging: Packaging should be disposed of responsibly, in accordance with Local Authority requirements

Section 14: Transportation Information

DOT TRANSPORT

DOT Proper Shipping Name: Not Regulated
ADR International Carriage of dangerous goods by road: Not Regulated
Rail Transport: Not Regulated
Sea Transport: Not Regulated
Air Transport: Not Regulated

IATA/ICAO CLASS

Page: 06/06

Section 15: Regularity Information

Directive: 67/548/EU

Label for Supply



Risk Phases

R – Phases:

R36 – Irritating Eyes

R38 – Irritating Skin

S- Phases

S24 – Avoid contact with skin

S25 – Avoid contact with eyes

Toxic Substances Control Act (TSCA) Status:

This product is in compliance with rules, regulations and orders of TSCA. All components are listed on TSCA inventory.

Superfund Amendments and reauthorisation act of 1986 (SARA). Title III Section 313 – Supplier Notification:

This regulation requires submission of annual reports of toxic chemical(s) that appear in section 313 of the Emergency

Planning and Community Right to Know Act of 1986 and 40 CFR 372. This information must be included in all MSDS's that are copied and distributed for the material.

The Section 313 toxic chemicals contained in this product are: None.

EU - INFORMATION

This product has been reviewed for compliance with the following EU directives:

REACH 1907/2006

Directive 67/548/EEC

Regulation (EC) No. 1272/2008 on classification, labelling, and packaging (CLP) of substances and mixtures.

Section 16: Other Information

EU Hazards Identification

R: None

S: None

Danger Symbols: None

Revision Comments: Updated January 2017 (UK only)

Revision No. 01

Information Sources/; RTECHS, REACH, OSHA 29CFR, 1910.1200

This material safety data sheet (MSDS) is offered solely for your information, consideration and investigation. The data described in this MSDS consists of data on literature, our acquisitioned data and analogical inference by data of similar chemical substances or products. Pro-Earth or ProCleanSorb provide no warranties, either expressed or implied, and assumes no responsibility for the accuracy or completeness of the data contained herein.

This data is offered in good faith as typical values and not as a product specification. No warranty, either expressed or implied, is made. The recommended handling procedures are believed to be generally applicable.

**SECTION 1: Identification of the substance/mixture and of the company/undertaking****1.1. Product identifier**

Product form : Mixture
Product name : ZENOVA FIRE EXTINGUISHER FX500 (BOV)
Product code : NPD12179
Vaporizer : Aerosol

1.2. Relevant identified uses of the substance or mixture and uses advised against**1.2.1. Relevant identified uses**

Intended for general public

1.2.2. Uses advised against

No additional information available

1.3. Details of the supplier of the safety data sheet

Zenova Limited
172 Arlington Road
London NW1 7HL
United Kingdom
T +44 (0) 2030 393977
info@zenovagroup.com , www.zenovagroup.com

1.4. Emergency telephone number

Emergency number : +44 (0) 2030 393977

Country/Area	Organisation/Company	Address	Emergency number	Comment
United Kingdom	National Poisons Information Service (Birmingham Centre) City Hospital	Dudley Road B18 7QH	0344 892 0111	Only for healthcare professionals

SECTION 2: Hazards identification**2.1. Classification of the substance or mixture****Classification according to Regulation (EC) No. 1272/2008 [CLP]**

Aerosol, Category 3 H229
Full text of H- and EUH-statements: see section 16

Adverse physicochemical, human health and environmental effects

Pressurised container: May burst if heated.

2.2. Label elements**Labelling according to Regulation (EC) No. 1272/2008 [CLP]**

Signal word (CLP) : Warning
Hazard statements (CLP) : H229 - Pressurised container: May burst if heated.
Precautionary statements (CLP) : P102 - Keep out of reach of children.
P210 - Keep away from heat, hot surfaces, sparks, open flames and other ignition sources.
No smoking.
P251 - Do not pierce or burn, even after use.
P410+P412 - Protect from sunlight. Do not expose to temperatures exceeding 50 °C/122 °F.

ZENOVA FIRE EXTINGUISHER FX500 (BOV)

500ML NPD12179

Safety Data Sheet according to the REACH Regulation (EC) 1907/2006 amended by Regulation (EU) 2020/878
Issue date: 18/11/2022 Revision date: 02/01/2024 Supersedes version of: 24/11/2022 Version: 3.0

2.3. Other hazards

The mixture does not contain substance(s) included in the list established in accordance with Article 59(1) of REACH for having endocrine disrupting properties, or substance(s) are not identified as having endocrine disrupting properties in accordance with the criteria set out in Commission Delegated Regulation (EU) 2017/2100 or Commission Regulation (EU) 2018/605 at a concentration equal to or greater than 0,1 %

SECTION 3: Composition/information on ingredients

3.1. Substances

Not applicable

3.2. Mixtures

Product subject to CLP Article 1.1.3.7. The disclosure rules of the components is modified in this case.
This mixture does not contain any substances to be mentioned according to the criteria of section 3.2 of REACH Annex II

SECTION 4: First aid measures

4.1. Description of first aid measures

First-aid measures general	: If you feel unwell, seek medical advice.
First-aid measures after inhalation	: Remove person to fresh air and keep comfortable for breathing.
First-aid measures after skin contact	: Wash skin with plenty of water.
First-aid measures after eye contact	: Rinse eyes with water as a precaution.
First-aid measures after ingestion	: Call a poison center or a doctor if you feel unwell.

4.2. Most important symptoms and effects, both acute and delayed

Symptoms/effects after inhalation	: Although no appropriate human or animal health effects data are known to exist, this material is expected to be an inhalation hazard.
Symptoms/effects after skin contact	: None under normal conditions.
Symptoms/effects after eye contact	: None under normal conditions.
Symptoms/effects after ingestion	: None under normal conditions.

4.3. Indication of any immediate medical attention and special treatment needed

Treat symptomatically.

SECTION 5: Firefighting measures

5.1. Extinguishing media

Suitable extinguishing media	: Water spray. Dry powder. Foam. Carbon dioxide.
Unsuitable extinguishing media	: Do not use a heavy water stream.

5.2. Special hazards arising from the substance or mixture

Fire hazard	: No fire hazard.
Explosion hazard	: Pressurised container: May burst if heated.
Hazardous decomposition products in case of fire	: Toxic fumes may be released.

5.3. Advice for firefighters

Firefighting instructions	: Fight fire from safe distance and protected location. Do not enter fire area without proper protective equipment, including respiratory protection.
Protection during firefighting	: Do not attempt to take action without suitable protective equipment. Self-contained breathing apparatus. Complete protective clothing.

ZENOVA FIRE EXTINGUISHER FX500 (BOV) 500ML NPD12179

Safety Data Sheet according to the REACH Regulation (EC) 1907/2006 amended by Regulation (EU) 2020/878
Issue date: 18/11/2022 Revision date: 02/01/2024 Supersedes version of: 24/11/2022 Version: 3.0

SECTION 6: Accidental release measures

6.1. Personal precautions, protective equipment and emergency procedures

General measures : Stop leak if safe to do so. Notify authorities if product enters sewers or public waters.
Absorb spillage to prevent material damage.

6.1.1. For non-emergency personnel

Protective equipment : Wear recommended personal protective equipment.
Emergency procedures : Ventilate spillage area. No open flames, no sparks, and no smoking.

6.1.2. For emergency responders

Protective equipment : Do not attempt to take action without suitable protective equipment. For further information refer to section 8: "Exposure controls/personal protection".
Emergency procedures : Evacuate unnecessary personnel. Stop leak if safe to do so.

6.2. Environmental precautions

Avoid release to the environment.

6.3. Methods and material for containment and cleaning up

For containment : Absorb spilled material with sand or earth. Contain any spills with dikes or absorbents to prevent migration and entry into sewers or streams. Stop leak without risks if possible.
Methods for cleaning up : Mechanically recover the product.
Other information : Dispose of materials or solid residues at an authorized site.

6.4. Reference to other sections

For further information refer to section 13.

SECTION 7: Handling and storage

7.1. Precautions for safe handling

Additional hazards when processed : Not expected to present a significant hazard under anticipated conditions of normal use.
Precautions for safe handling : Ensure good ventilation of the work station. Wear personal protective equipment. Keep away from heat, hot surfaces, sparks, open flames and other ignition sources. No smoking.
Do not pierce or burn, even after use.
Hygiene measures : Do not eat, drink or smoke when using this product. Always wash hands after handling the product.

7.2. Conditions for safe storage, including any incompatibilities

Technical measures : Keep in a cool, well-ventilated place away from heat.
Storage conditions : Protect from sunlight. Do not expose to temperatures exceeding 50 °C/ 122 °F.
Packaging materials : Store always product in container of same material as original container.

Switzerland

Storage class (LK) : LK 2 - Liquefied or pressurized gases

7.3. Specific end use(s)

No additional information available

SECTION 8: Exposure controls/personal protection

8.1. Control parameters

8.1.1 National occupational exposure and biological limit values

No additional information available

ZENOVA FIRE EXTINGUISHER FX500 (BOV)

500ML NPD12179

Safety Data Sheet according to the REACH Regulation (EC) 1907/2006 amended by Regulation (EU) 2020/878
Issue date: 18/11/2022 Revision date: 02/01/2024 Supersedes version of: 24/11/2022 Version: 3.0

8.1.2. Recommended monitoring procedures

No additional information available

8.1.3. Air contaminants formed

No additional information available

8.1.4. DNEL and PNEC

No additional information available

8.1.5. Control banding

No additional information available

8.2. Exposure controls

8.2.1. Appropriate engineering controls

Appropriate engineering controls:

Ensure good ventilation of the work station.

8.2.2. Personal protection equipment

Personal protective equipment:

Wear recommended personal protective equipment.

Personal protective equipment symbol(s):



8.2.2.1. Eye and face protection

Eye protection:

Safety glasses

8.2.2.2. Skin protection

Skin and body protection:

Wear suitable protective clothing

Hand protection:

Protective gloves

8.2.2.3. Respiratory protection

Respiratory protection:

In case of insufficient ventilation, wear suitable respiratory equipment

8.2.2.4. Thermal hazards

No additional information available

8.2.3. Environmental exposure controls

Environmental exposure controls:

Avoid release to the environment.

SECTION 9: Physical and chemical properties

9.1. Information on basic physical and chemical properties

Physical state	: Liquid
Colour	: clear.
Odour	: characteristic.
Odour threshold	: Not available
Melting point	: Not applicable
Freezing point	: Not available

ZENOVA FIRE EXTINGUISHER FX500 (BOV)

500ML NPD12179

Safety Data Sheet according to the REACH Regulation (EC) 1907/2006 amended by Regulation (EU) 2020/878
Issue date: 18/11/2022 Revision date: 02/01/2024 Supersedes version of: 24/11/2022 Version: 3.0

Boiling point	: Not available
Flammability	: Non flammable.
Explosive properties	: Pressurised container: May burst if heated.
Lower explosion limit	: Not available
Upper explosion limit	: Not available
Flash point	: Not applicable
Auto-ignition temperature	: Not available
Decomposition temperature	: Not available
pH	: Not available
Viscosity, kinematic	: Not available
Solubility	: Not available
Partition coefficient n-octanol/water (Log Kow)	: Not available
Vapour pressure	: Not available
Vapour pressure at 50°C	: Not available
Density	: Not available
Relative density	: Not available
Relative vapour density at 20°C	: Not available
Particle characteristics	: Not applicable

9.2. Other information

9.2.1. Information with regard to physical hazard classes

% of flammable ingredients :

9.2.2. Other safety characteristics

No additional information available

SECTION 10: Stability and reactivity

10.1. Reactivity

Pressurised container: May burst if heated.

10.2. Chemical stability

Stable under normal conditions.

10.3. Possibility of hazardous reactions

No dangerous reactions known under normal conditions of use.

10.4. Conditions to avoid

Avoid contact with hot surfaces. Heat. No flames, no sparks. Eliminate all sources of ignition.

10.5. Incompatible materials

No additional information available

10.6. Hazardous decomposition products

Under normal conditions of storage and use, hazardous decomposition products should not be produced.

SECTION 11: Toxicological information

11.1. Information on hazard classes as defined in Regulation (EC) No 1272/2008

Acute toxicity (oral)	: Not classified
Acute toxicity (dermal)	: Not classified
Acute toxicity (inhalation)	: Not classified
Skin corrosion/irritation	: Not classified
Serious eye damage/irritation	: Not classified
Respiratory or skin sensitisation	: Not classified

ZENOVA FIRE EXTINGUISHER FX500 (BOV) 500ML NPD12179

Safety Data Sheet according to the REACH Regulation (EC) 1907/2006 amended by Regulation (EU) 2020/878
Issue date: 18/11/2022 Revision date: 02/01/2024 Supersedes version of: 24/11/2022 Version: 3.0

Germ cell mutagenicity	: Not classified
Carcinogenicity	: Not classified
Reproductive toxicity	: Not classified
STOT-single exposure	: Not classified
STOT-repeated exposure	: Not classified
Aspiration hazard	: Not classified

ZENOVA FIRE EXTINGUISHER FX500 (BOV) - 500ML NPD12179

Vaporizer	Aerosol
-----------	---------

11.2. Information on other hazards

No additional information available

SECTION 12: Ecological information

12.1. Toxicity

Ecology - general	: The product is not considered harmful to aquatic organisms nor to cause long-term adverse effects in the environment.
Hazardous to the aquatic environment, short-term (acute)	: Not classified
Hazardous to the aquatic environment, long-term (chronic)	: Not classified

12.2. Persistence and degradability

ZENOVA FIRE EXTINGUISHER FX500 (BOV) - 500ML NPD12179

Persistence and degradability	Not rapidly degradable
-------------------------------	------------------------

12.3. Bioaccumulative potential

No additional information available

12.4. Mobility in soil

No additional information available

12.5. Results of PBT and vPvB assessment

No additional information available

12.6. Endocrine disrupting properties

No additional information available

12.7. Other adverse effects

No additional information available

SECTION 13: Disposal considerations

13.1. Waste treatment methods



Regional waste regulation	: Disposal must be done according to official regulations.
Waste treatment methods	: Dispose of contents/container in accordance with licensed collector's sorting instructions.
Sewage disposal recommendations	: Disposal must be done according to official regulations.
Product/Packaging disposal recommendations	: Disposal must be done according to official regulations.
Additional information	: Do not re-use empty containers.

ZENOVA FIRE EXTINGUISHER FX500 (BOV) 500ML NPD12179

Safety Data Sheet according to the REACH Regulation (EC) 1907/2006 amended by Regulation (EU) 2020/878
Issue date: 18/11/2022 Revision date: 02/01/2024 Supersedes version of: 24/11/2022 Version: 3.0

SECTION 14: Transport information

In accordance with ADR / IATA

ADR	IATA
14.1. UN number or ID number	
UN 1950	UN 1950
14.2. UN proper shipping name	
AEROSOLS	Aerosols, non-flammable
Transport document description	
UN 1950 AEROSOLS, 2.2, (E)	UN 1950 Aerosols, non-flammable, 2.2
14.3. Transport hazard class(es)	
2.2	2.2
	
14.4. Packing group	
Not applicable	Not applicable
14.5. Environmental hazards	
Dangerous for the environment: No	Dangerous for the environment: No
No supplementary information available	

14.6. Special precautions for user

Overland transport

Classification code (ADR)	: 5A
Special provisions (ADR)	: 190, 327, 344, 625
Limited quantities (ADR)	: 1I
Excepted quantities (ADR)	: E0
Packing instructions (ADR)	: P207, LP200
Special packing provisions (ADR)	: PP87, RR6, L2
Mixed packing provisions (ADR)	: MP9
Transport category (ADR)	: 3
Special provisions for carriage - Packages (ADR)	: V14
Special provisions for carriage - Loading, unloading and handling (ADR)	: CV9, CV12
Tunnel restriction code (ADR)	: E

Air transport

PCA Excepted quantities (IATA)	: E0
PCA Limited quantities (IATA)	: Y203
PCA limited quantity max net quantity (IATA)	: 30kgG
PCA packing instructions (IATA)	: 203
PCA max net quantity (IATA)	: 75kg
CAO packing instructions (IATA)	: 203
CAO max net quantity (IATA)	: 150kg
Special provisions (IATA)	: A98, A145, A167, A802
ERG code (IATA)	: 2L

14.7. Maritime transport in bulk according to IMO instruments

Not applicable

ZENOVA FIRE EXTINGUISHER FX500 (BOV) 500ML NPD12179

Safety Data Sheet according to the REACH Regulation (EC) 1907/2006 amended by Regulation (EU) 2020/878
Issue date: 18/11/2022 Revision date: 02/01/2024 Supersedes version of: 24/11/2022 Version: 3.0

SECTION 15: Regulatory information

15.1. Safety, health and environmental regulations/legislation specific for the substance or mixture

15.1.1. EU-Regulations

REACH Annex XVII (Restriction List)

Contains no substance(s) listed on REACH Annex XVII (Restriction Conditions)

REACH Annex XIV (Authorisation List)

Contains no substance(s) listed on REACH Annex XIV (Authorisation List)

REACH Candidate List (SVHC)

Contains no substance(s) listed on the REACH Candidate List

PIC Regulation (Prior Informed Consent)

Contains no substance(s) listed on the PIC list (Regulation EU 649/2012 concerning the export and import of hazardous chemicals)

POP Regulation (Persistent Organic Pollutants)

Contains no substance(s) listed on the POP list (Regulation EU 2019/1021 on persistent organic pollutants)

Ozone Regulation (1005/2009)

Contains no substance(s) listed on the Ozone Depletion list (Regulation EU 1005/2009 on substances that deplete the ozone layer)

Dual-Use Regulation (428/2009)

Contains no substance subject to the COUNCIL REGULATION (EC) No 428/2009 of 5 May 2009 setting up a Community regime for the control of exports, transfer, brokering and transit of dual-use items.

Explosives Precursors Regulation (2019/1148)

Contains no substance(s) listed on the Explosives Precursors list (Regulation EU 2019/1148 on the marketing and use of explosives precursors)

Drug Precursors Regulation (273/2004)

Contains no substance(s) listed on the Drug Precursors list (Regulation EC 273/2004 on the manufacture and the placing on market of certain substances used in the illicit manufacture of narcotic drugs and psychotropic substances)

15.1.2. National regulations

Germany

- Employment restrictions : Observe restrictions according Act on the Protection of Working Mothers (MuSchG).
Observe restrictions according Act on the Protection of Young People in Employment (JArbSchG).
- Water hazard class (WGK) : Not classified according to Regulation Governing Systems for Handling Substances Hazardous to Waters (AwSV).
- Hazardous Incident Ordinance (12. BImSchV) : Is not subject of the Hazardous Incident Ordinance (12. BImSchV)

Switzerland

- Storage class (LK) : LK 2 - Liquefied or pressurized gases

15.2. Chemical safety assessment

No chemical safety assessment has been carried out

SECTION 16: Other information

Abbreviations and acronyms:

ADN	European Agreement concerning the International Carriage of Dangerous Goods by Inland Waterways
ADR	European Agreement concerning the International Carriage of Dangerous Goods by Road
ATE	Acute Toxicity Estimate
BCF	Bioconcentration factor
BLV	Biological limit value

ZENOVA FIRE EXTINGUISHER FX500 (BOV) 500ML NPD12179

Safety Data Sheet according to the REACH Regulation (EC) 1907/2006 amended by Regulation (EU) 2020/878
Issue date: 18/11/2022 Revision date: 02/01/2024 Supersedes version of: 24/11/2022 Version: 3.0

BOD	Biochemical oxygen demand (BOD)
-----	---------------------------------

ZENOVA FIRE EXTINGUISHER FX500 (BOV) 500ML NPD12179

Safety Data Sheet according to the REACH Regulation (EC) 1907/2006 amended by Regulation (EU) 2020/878
Issue date: 18/11/2022 Revision date: 02/01/2024 Supersedes version of: 24/11/2022 Version: 3.0

Abbreviations and acronyms:

COD	Chemical oxygen demand (COD)
DMEL	Derived Minimal Effect level
DNEL	Derived-No Effect Level
EC-No.	European Community number
EC50	Median effective concentration
EN	European Standard
IARC	International Agency for Research on Cancer
IATA	International Air Transport Association
IMDG	International Maritime Dangerous Goods
LC50	Median lethal concentration
LD50	Median lethal dose
LOAEL	Lowest Observed Adverse Effect Level
NOAEC	No-Observed Adverse Effect Concentration
NOAEL	No-Observed Adverse Effect Level
NOEC	No-Observed Effect Concentration
OECD	Organisation for Economic Co-operation and Development
OEL	Occupational Exposure Limit
PBT	Persistent Bioaccumulative Toxic
PNEC	Predicted No-Effect Concentration
RID	Regulations concerning the International Carriage of Dangerous Goods by Rail
SDS	Safety Data Sheet
STP	Sewage treatment plant
ThOD	Theoretical oxygen demand (ThOD)
TLM	Median Tolerance Limit
VOC	Volatile Organic Compounds
CAS-No.	Chemical Abstract Service number
N.O.S.	Not Otherwise Specified
vPvB	Very Persistent and Very Bioaccumulative
ED	Endocrine disrupting properties

Full text of H- and EUH-statements:

H229	Pressurised container: May burst if heated.
------	---

Safety Data Sheet (SDS), EU

This information is based on our current knowledge and is intended to describe the product for the purposes of health, safety and environmental requirements only. It should not therefore be construed as guaranteeing any specific property of the product.



Best ALL IN ONE fire extinguisher.
EN3 certified.

Safe to use on any type of fire.
The only fire extinguisher you will ever need.

The Zenova FX2L is a fire extinguisher range that is effective and safe to use on all types of fires, taking the guesswork out of tackling fires. No more confusion on which extinguisher to use for different fire classes – use the Zenova FX2L for any type of fire.

- ✓ Can put out A, B, C, D, Electrical & F fires.

Zenova FX2L extinguishers are fully compliant with PFOA, PFOS and PFAS EU standards and regulations and are compliant with the ECHA Proposed Annex XV Restriction v2.0 to REACH - trace PFAS elements are well below the current standards and below the proposed new standards.



TESTED							
CERTIFIED							
	13A	55B			Safe for use on live electrical equipment up to 1000V	40F	

Features

- ✓ Easy operation,
- ✓ Fast and effective extinguishing.
- ✓ Economical maintenance and service
- Stainless steel tank
- Polyethylene internal lining
- Corrosion-resistant finish



Quality and safety

Manufactured for all EU market requirements based on certified ISO 9001 quality system.

Inspection recommended every 12 months. Use only spare parts in accordance with approved sample of fire extinguisher.

Technical Data

Size:	2L
Extinguishing agent:	Zenova FX fluid
Cylinder test pressure:	27 bar
Propellant:	Nitrogen
Operation pressure:	15 bar at 20°C
Operating temperature:	+5°C / +50°C

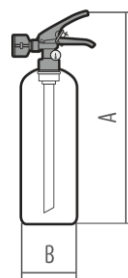



















Total height (A)
368mm

Cylinder diameter (B)
110mm

Best ALL IN ONE fire extinguisher.
EN3 certified.
Safe to use on any type of fire.
The only fire extinguisher you will ever need.

Application

The Zenova FX6L, is a fire extinguisher range that is effective and safe to use on all types of fires, taking the guesswork out of tackling fires. Zenova FX6L for any type of fire
Zenova FX6L extinguishers can put out A, B, C, D, Electrical & F fires.
Zenova FX6L extinguishers are EN3 certified for A, B, Electrical & F fires.
No more confusion on which extinguisher to use for what fire type.

							
TESTED							
CERTIFIED							
	34A	113B			35kV	75F	

Features

- ✓ Easy operation,
- ✓ Fast and effective extinguishing.
- ✓ Economical maintenance and service
- ✓ Cut-off valve behind the pressure gauge makes control of the extinguisher easier

Quality and safety

Manufactured for all EU market requirements based on certified ISO 9001 quality system. Fulfils European Standard EN3 and Safety Directive PED 2014/68/UE.

Inspection should be made every 12 months at least. Use only spare parts in accordance with approved sample of fire extinguisher.





Technical Data

Weight of extinguishing agent	6.0 kg
Extinguishing agent	6 litre Zenova FX fluid
Cylinder test pressure	27 bar
Propellant:	Nitrogen
Operation pressure	15 bar at 20°C
Operating temperature	+5°C / +50°C
Total weight	9.3 kg
Total height	502 mm
Cylinder diameter	160 mm

- Corrosion-resistant finish
- Plastic base skirt for protection
- Polyethylene internal lining

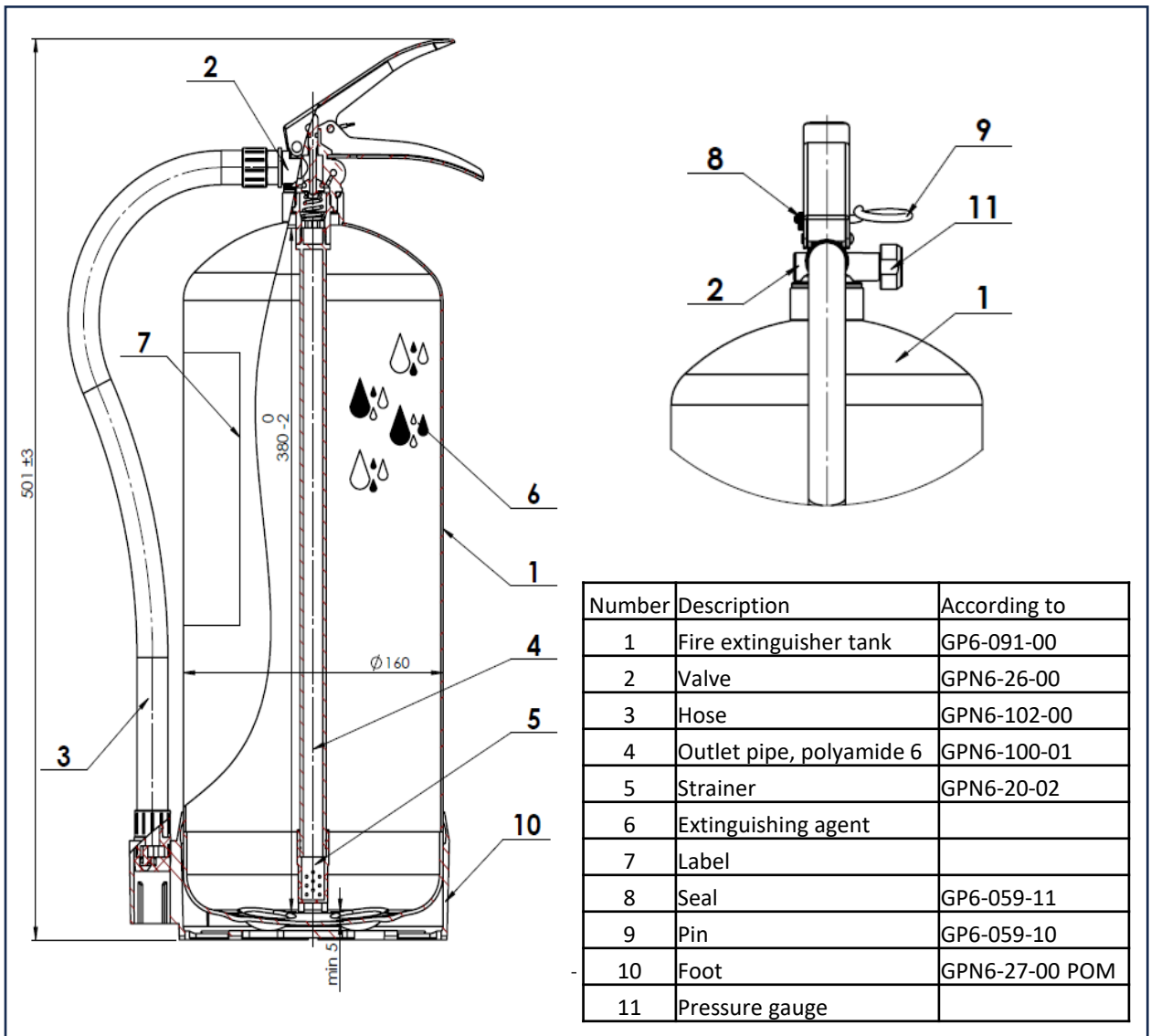

Number	Description	According to
1	Fire extinguisher tank	GP6-091-00
2	Valve	GPN6-26-00
3	Hose	GPN6-102-00
4	Outlet pipe, polyamide 6	GPN6-100-01
5	Strainer	GPN6-20-02
6	Extinguishing agent	
7	Label	
8	Seal	GP6-059-11
9	Pin	GP6-059-10
10	Foot	GPN6-27-00 POM
11	Pressure gauge	



Best ALL IN ONE fire extinguisher.
 EN3 certified.
 Safe to use on any type of fire.
 The only fire extinguisher you will ever need.

Application

The Zenova FX9L, is a fire extinguisher range that is effective and safe to use on all types of fires, taking the guesswork out of tackling fires. Zenova FX9L for any type of fire
 Zenova FX9L extinguishers can put out A, B, C, D, Electrical & F fires.
 Zenova FX9L extinguishers are EN3 certified for A, B, Electrical & F fires.
 No more confusion on which extinguisher to use for what fire type.

TESTED							
CERTIFIED							
	43A	183B			35kV	75F	

Features

- ✓ Easy operation,
- ✓ Fast and effective extinguishing.
- ✓ Economical maintenance and service
- ✓ Cut-off valve behind the pressure gauge makes control of the extinguisher easier

Quality and safety

Manufactured for all EU market requirements based on certified ISO 9001 quality system. Fulfils European Standard EN3 and Safety Directive PED 2014/68/UE.

Inspection should be made every 12 months at least. Use only spare parts in accordance with approved sample of fire extinguisher.

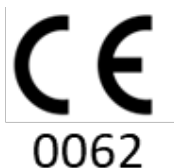



Technical Data

Weight of extinguishing agent	9.0 kg
Extinguishing agent	9 litre Zenova FX fluid
Cylinder test pressure	27 bar
Propellant:	Nitrogen
Operation pressure	15 bar at 20°C
Operating temperature	+5°C / +50°C
Total weight	9.3 kg
Total height	576 mm
Cylinder diameter	185 mm

- Corrosion-resistant finish
- Plastic base skirt for protection
- Polyethylene internal lining

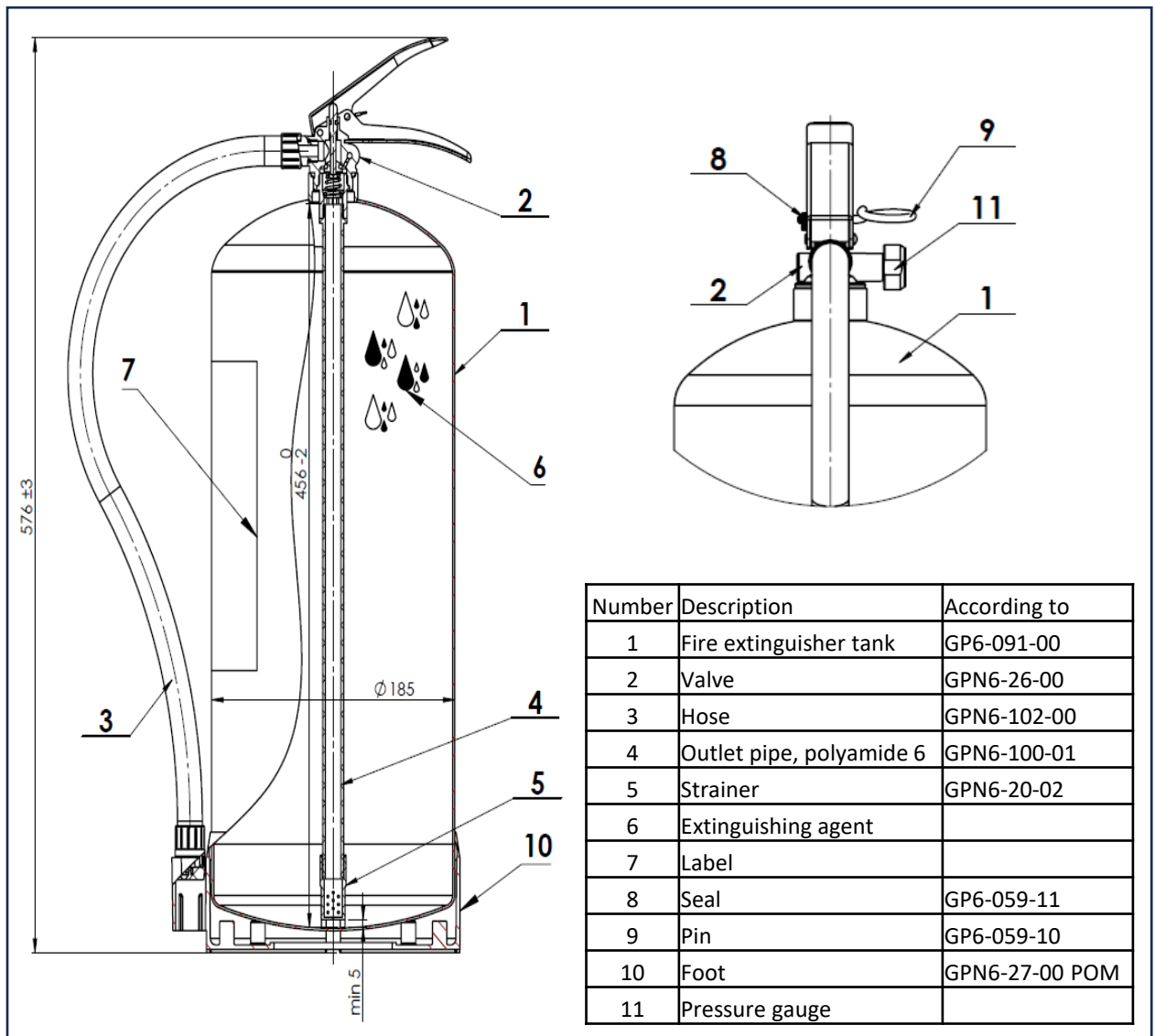

Number	Description	According to
1	Fire extinguisher tank	GP6-091-00
2	Valve	GPN6-26-00
3	Hose	GPN6-102-00
4	Outlet pipe, polyamide 6	GPN6-100-01
5	Strainer	GPN6-20-02
6	Extinguishing agent	
7	Label	
8	Seal	GP6-059-11
9	Pin	GP6-059-10
10	Foot	GPN6-27-00 POM
11	Pressure gauge	