



Main applications

- Extrusion, injection, blow moulding, thermoforming of plastics
- Vulcanization of rubber
- Synthetic fibre production and polymerisation
- Packing and packaging
- Dryers for ceramics and building elements
- Industrial electric ovens
- Food processing plants
- Chemical and pharmaceutical industry



Main features

- Ultra-compact dimensions from 15A to 120A
- Switching at zero voltage changeover
- Input command from DC/AC logic signal with push-in connectors; signalling leds
- Cage clamps for power cables
- Load voltage 480V, 600V AC
- SCCR 100 kA
- Thermal alarm option with led and alarm output
- Interrupted load option with led and alarm output
- Internal overvoltage protection

PROFILE

Correct management of electrical heating elements for industrial heating applications requires robust, safe, interference-free, fast and diagnostically capable static contactors.

The range of static contactors GRS meets all these requirements, with current ratings from 15 to 120 Amperes and voltages up to 600 V AC, with extremely compact size in every single current level.

It's necessary use the relay with a proper heat sink (see section accessory). Accessories like heat sink, fuses and fans are available.

GRS COMMAND SIGNAL CONNECTION

The GRS series can be controlled by DC and AC logical signals managed through push-in connectors for a faster and easier connection, even without tools.

The ON / OFF status of the static device is always displayed by a green LED on the front panel, for an immediate view of its operation.

POWER CONNECTIONS

Both the line voltage terminal available on the upper part of the device and the load terminal on the lower part are of the "cage" type, which offers the best and safest seal even for cables of different cross-sections, whether mounted with a cable lug or simply stripped.

DIAGNOSTICS AND ALARMS

It is increasingly vital for operators and maintainers to recognize possible anomalies in the system immediately and solve them quickly in order to ensure the efficiency and profitability of machinery and plants. The GRS series offers a series of diagnostic information associated with a physical alarm output with voltage-free or PNP-type isolated contact.

The thermal alarm is triggered if heat dissipation exceeds a critical threshold, signalling it with a yellow led on the front panel, interrupting the power supply and triggering the alarm output (NO or NC). This function is available as an option for all current levels.

The absence of current on the load (for models with DC control) is indicated by a red led on the front panel and by the activation of the alarm output, as well as by the absence of line voltage.

Alarm output status is memorized: in the presence of a 24 V DC auxiliary power supply, the alarm will be memorized even in the event of an OFF command.

The alarm is reset when normal operating conditions are restored, or when the 24 V DC auxiliary power supply is switched off and on again.

TECHNICAL DATA

Main features

Category of use: AC51

Rated working voltage

- 480Vac (max. range 24...530Vac)

- 600Vac (max range 24 ... 660Vac)

Rated frequency: 50/60Hz

Non-repetitive voltage:

- 1200Vp for model with rated voltage 480Vac

- 1400Vp for model with rated voltage 600Vac

Switching voltage for zero: < 20V

Activation time: = 1/2 cycle

Deactivation time: = 1/2 cycle

Potential drop at rated current:

= < 1,2Vrms

Power factor = 1

Control input

- DC INPUT

Type DD-0 ":

Max. input: < 9mA @32V

Max. reverse voltage: 36Vdc

Control voltage: 5,1...32Vdc

Activation voltage: > 5,1Vdc

Deactivation voltage: < 5Vdc

Input impedance 500 kΩ

Type 1/2/3/5 ":

Control supply 6 to 32 Vdc,

I_{max} < 14 mA at 32V)

Massima tensione inversa: 36Vdc

Maximum control signal current absorption: <3.2mA

@32V

Control voltage: 3...32Vdc
Activation voltage: > 3Vdc
Deactivation voltage: < 1,8Vdc
Input impedance 9,45 kΩ

- AC INPUT (Type "A"):

Control voltage:

INSTALL FUSE (3A MAX) ON THE CONTROL INPUT CIRCUIT

Activation voltage:

Deactivation voltage:

Control voltage @ 260 Vac/Vdc

Alarm Output Option

(Type "D" Input Version)

A load or line failure or an overtemperature alarm commands:

- Options 1/2/5: one voltage-free contact (solid state N.C or N.O.), max. properties:
- N.O. version 30V-150mA conduction resistance: $\leq 1\Omega$
- N.C. version 30V-50mA conduction resistance: $\leq 15\Omega$
- Option 3: two normally inactive (parallelable) PNP digital outputs, one for load failure and the other for overtemperature (properties: $I_{max} = 150mA$ $V_{out} = +V$ DC power supply -1V).

Maximum interrupted load alarm trip delay < 400ms

Alarm Output Option

(Type "A" Input Version)

The over-temperature alarm commands a voltage-free contact (solid state N.C.), max. properties:

30V-50mA conduction resistance: $\leq 15\Omega$

Outputs

GRS 15

Rated device current with appropriate heatsink: 15 A@40°C in continuous service
Non-repetitive overcurrent t=20 ms:

620A

I²t for blowout: $\leq 1800A^2s$
dV/dt critical with output deactivated: 1000V/ μs

GRS 25

Rated device current with appropriate heatsink: 25 A@40°C in continuous service

Non-repetitive overcurrent t=20 ms: 620A

I²t for blowout: $\leq 1800A^2s$

dV/dt critical with output deactivated: 1000V/ μs

GRS 25I

Rated device current: 25 A@40°C in continuous service

Non-repetitive overcurrent t=20 ms:

1600A

I²t for blowout $\leq 12800A^2s$

dV/dt critical with output deactivated

1000V/ μs

GRS 30

Rated device current with appropriate heatsink: 30 A@40°C in continuous

service

Non-repetitive overcurrent t=20 ms: 620A

I²t for blowout: $\leq 1800A^2s$

dV/dt critical with output deactivated: 1000V/ μs

GRS 30I

Rated device current 30 A@40°C in continuous service

Non-repetitive overcurrent t=20 ms:

1600A

I²t for blowout: $\leq 12800A^2s$

dV/dt critical with output deactivated:

1000V/ μs

GRS 40

Rated device current with appropriate heatsink: 40 A@40°C in continuous service

Non-repetitive overcurrent t=20 ms:

620A

I²t for blowout: $\leq 1800A^2s$

dV/dt critical with output deactivated: 1000 V/ μs

GRS 50

Rated device current with appropriate heatsink: 50 A@ 40°C in continuous service

Non-repetitive overcurrent t=20 ms:

1600A

I²t for blowout: $\leq 12800A^2s$

dV/dt critical with output deactivated:

1000V/ μs

GRS 60

Rated device current with appropriate heatsink: 60 A@ 40°C in continuous service

Non-repetitive overcurrent t=20 ms:

1600A

I²t for blowout: $\leq 12800A^2s$

dV/dt critical with output deactivated: 1000V/ μs

GRS 75

Rated device current with appropriate heatsink: 75 A@ 40°C in continuous service

Non-repetitive overcurrent t=20 ms:

1600A

I²t for blowout: $\leq 12800A^2s$

dV/dt critical with output deactivated:

1000V/ μs

GRS 90

Rated device current with appropriate heatsink: 90A@40°C in continuous service

Non-repetitive overcurrent t=20 ms: 1500A

I²t for blowout: $\leq 11250A^2s$

dV/dt critical with output deactivated:

1000V/ μs

GRS 120

Rated device current with appropriate heatsink: 120A@40°C in continuous service

Non-repetitive overcurrent t=20 ms: 1500A

I²t for blowout: $\leq 11250A^2s$

dV/dt critical with output deactivated:

1000V/ μs

THERMAL PROTECTION

(Optional, always present in GRS with current size $\geq 50A$):

The temperature of the SCR module is constantly monitored inside the device.

When the maximum temperature threshold of the internal SCR is exceeded, current conduction to the load is interrupted and the yellow thermal protection LED comes on to signal the condition.

Thermal Characteristics

GRS 15

Junction temp: $\leq 125^\circ C$

Rth junction/case: $\leq 0,6^\circ C/W$

GRS 25

Junction temp: $\leq 125^\circ C$

Rth junction/case: $\leq 0,6^\circ C/W$

GRS 30

Junction temp: $\leq 125^\circ C$

Rth junction/case: $\leq 0,65^\circ C/W$

GRS 40

Junction temp: $\leq 125^\circ C$

Rth junction/case: $\leq 0,6^\circ C/W$

GRS 50

Junction temp: $\leq 125^\circ C$

Rth junction/case: $\leq 0,35^\circ C/W$

GRS 60

Junction temp: $\leq 125^\circ C$

Rth junction/case: $\leq 0,35^\circ C/W$

GRS 75

Junction temp: $\leq 125^\circ C$

Rth junction/case: $\leq 0,3^\circ C/W$

GRS 90

Junction temp: $\leq 125^\circ C$

Rth junction/case: $\leq 0,3^\circ C/W$

GRS 120

Junction temp: $\leq 125^\circ C$

Rth junction/case: $\leq 0,3^\circ C/W$

Calculation of the Power Dissipated By

the Solid State Relay

Single-phase static relay

$P_d = 1.2 \cdot I_{RMS} [W]$ (for GRS)

I_{RMS} = single-phase load current

Calculation of the heatsink Thermal

Resistance

$R_{th} = (90^\circ C - T_{amb. max}) / P_d$ with P_d = power dissipation

Max amb. T.= maximum air temperature in the electrical cabinet.

Use a heatsink with lower than calculated heat resistance (Rth).

Isolation

Rated isolation voltage input/output: 4000VACrms 1min



Ambient conditions

- **Working temperature:** from 0 to 80°C
- **Max. relative humidity:** 90% non-condensing at 40°C
- **Max. installation altitude:** 6600ft above sea level
- **Pollution level :** 2
- **Storage temperature:** -20..+85°C

Installation notes

Use the extra-rapid fuse shown in the catalogue according to the connection example supplied.

Applications with static units must also include a safety circuit breaker for disconnecting the power line from the load. Protect the SSR from over-temperature using an appropriate heatsink (accessory). The heatsink must be appropriately scaled for the ambient temperature and load current (refer to technical documentation).

-Mounting procedure on the heatsink:

The module-heatsink contact surface must have a maximum flatness error of 0.05mm and a maximum roughness of 0.02mm. The anchorage holes on the heatsink must be threaded and

countersunk.

Caution: Spread 1 gram of heat-conducting silicone paste (DOW CORNING 340 HeatSink is recommended) on the dissipative metal surface of the module. The surfaces must be clean, and there must be no impurities in the heat-conducting paste.

Tighten the two fixing screws alternately until a torque of 0.60 Nm / 5.3 lb.in for M4 screws and 0.75 Nm / 6.6 lb.in for M5 screws is reached.

Wait 30 minutes so that the excess paste can drain away. Tighten the two fixing screws alternately until a torque of 1.2 Nm / 10.6 lb.in for M4 screws and 1.5 Nm / 13.3 lb.in for M5 screws is reached. It is recommended that you check the soundness of the execution by disassembling a sample module to check that there are no air bubbles under the copper plate.

Mount the device vertically (maximum 10° inclination from the vertical axis)

- Vertical distance between a device and the panel wall >50mm
- Horizontal distance between a device and the panel wall at least 20mm
- Vertical distance between one device and another at least 50mm.

- Horizontal distance between one device and another at least 20mm. Make sure that the cable ducts do not reduce these distances; in this case, mount the units overhanging the panel, so that the air can flow vertically on the heat sink without hindrance.

Limits of use

- Ambient temperature limits.
- Need for air exchange with the outside or an air conditioner to transfer the dissipated power to the outside of the panel.
- Installation limits (distances between devices to ensure dissipation under natural convection conditions)
- Maximum voltage limits and derivative of the transients present on the line, for which the static unit provides internal protection devices (depending on the models).
- Presence of leakage current < 3mA (max. value with nominal voltage and junction temperature of 125°C).



DIMENSIONS AND MOUNTING MEASUREMENTS

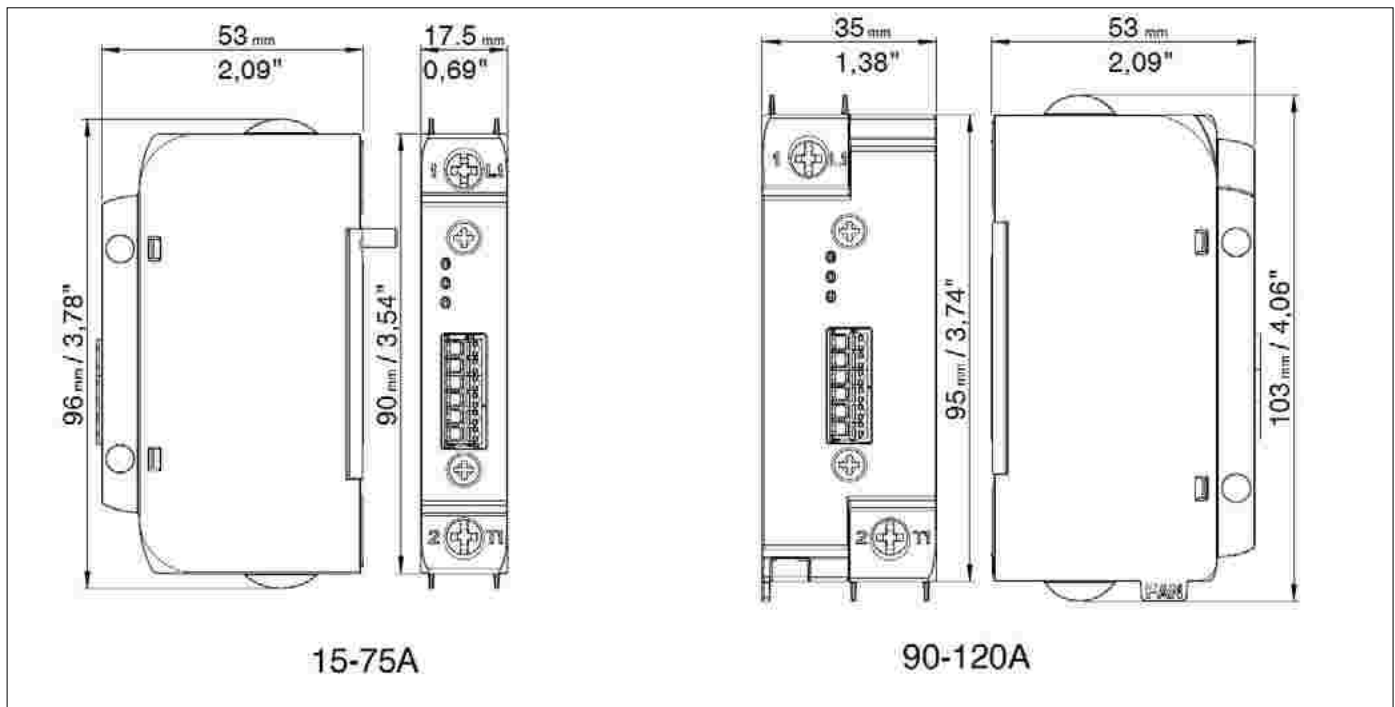

Model	15-75A	90-120A
Weight [g]	108	156

Notes:

The dimensions are representative of all models of the series (command "D"/"DD" type, "A" type and with options)

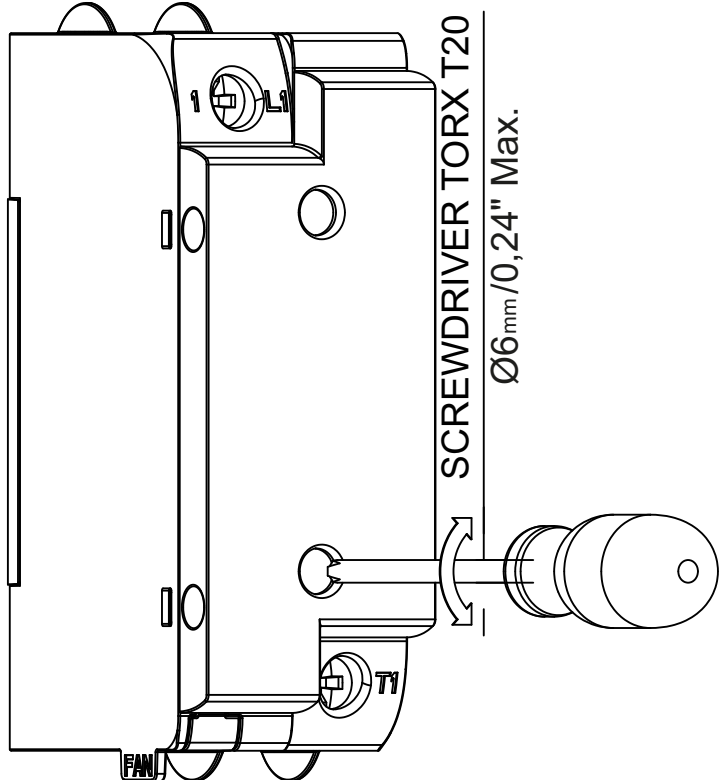
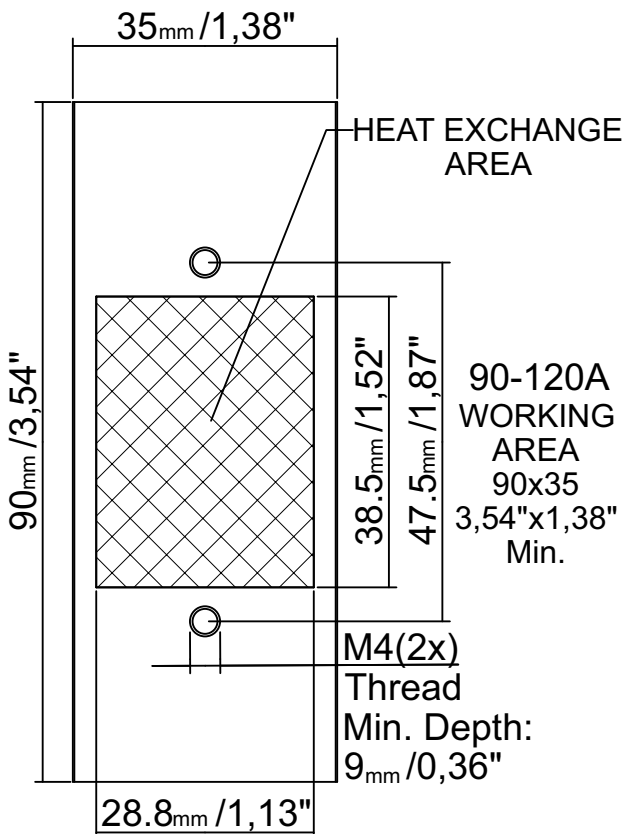
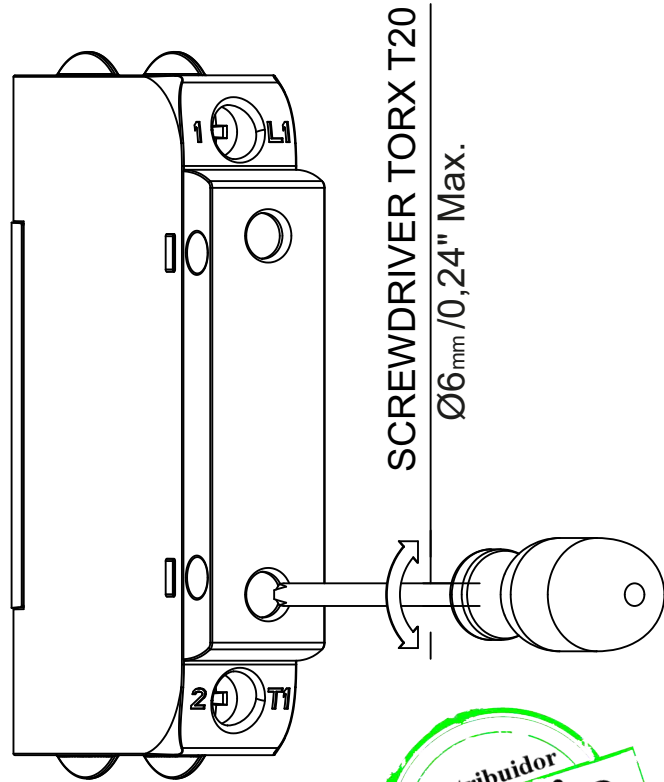
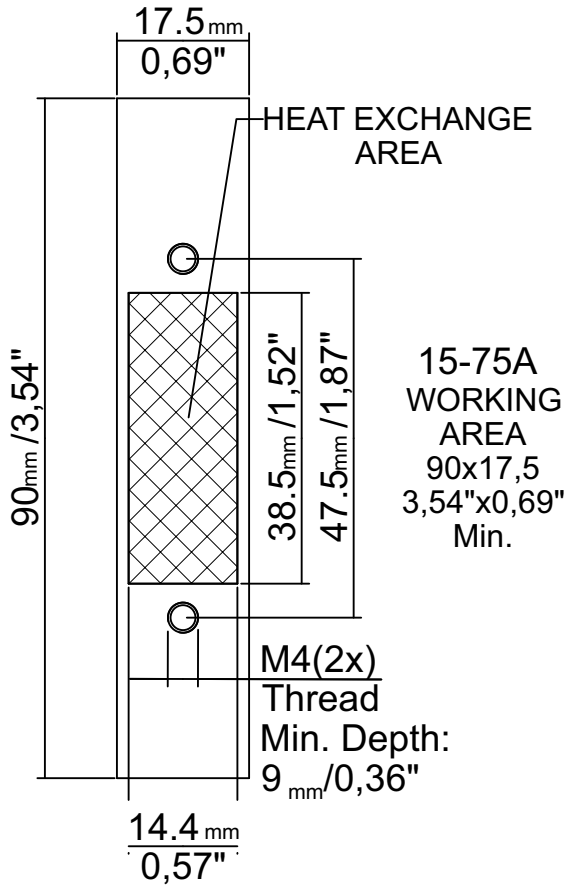

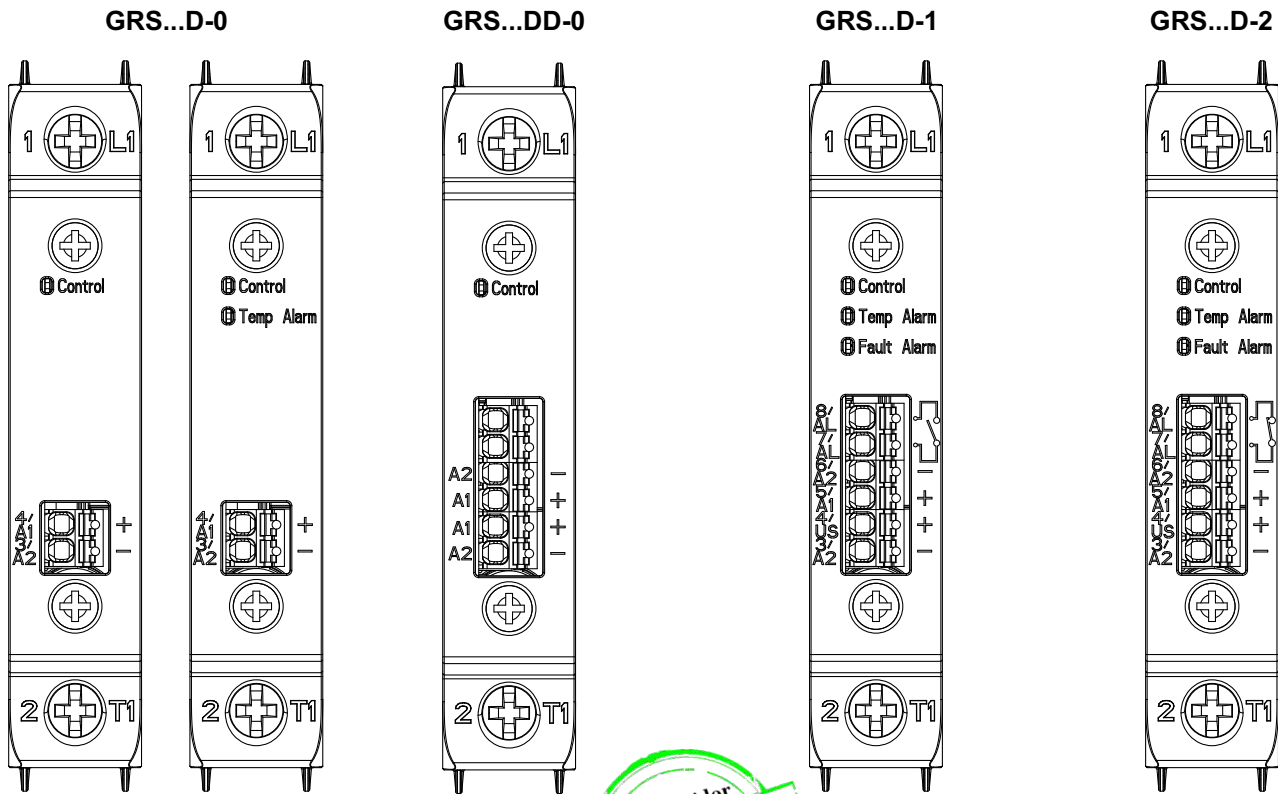

Description of terminal/connector versions with type "D"/"DD" input

Power terminals (common to all versions) (Overvoltage Category III)

Rif.	Description	Notes
1/L1	Line Connection	
2/T1	Load Connection	

Signal connector version without options (GRS...D-0) (Overvoltage Category II o III)

3/A2-	GND Control input ON/OFF	Control input ground
4/A1+	+Vdc control input ON/OFF	Range from 6 to 32 Vdc, I _{max} <9 mA at 32V

Signal connector version without options (GRS...DD-0) (Overvoltage Category II o III)

3/A2-	GND control input ON/OFF	Control input ground
4/A1+	+Vdc control input ON/OFF	Range from 6 to 32 Vdc, I _{max} <9 mA at 32V
5/A1+	+Vdc control input ON/OFF	Range from 6 to 32 Vdc, I _{max} <9 mA at 32V
6/A2-	GND control input ON/OFF	Control input ground

Signal connector version with options "1" and "2" type (GRS...D-1/2) (Overvoltage Category II o III)

3/A2-	GND for power supply and control input ON/OFF		
4/Us	+ Vdc power supply	Power supply GRS (Range from 6 to 32 V DC, I _{max} < 14 mA at 32V)	
5/A1+	+Vdc control input ON/OFF	Range: ON from 5 to 32Vdc, I _{max} <0,5 mA a 32V	OFF < 1,8V
6/A2-	GND Control input ON/OFF (common to terminal 3/A2-)	Additional connection to be used only as GND for the control signal	
7/AL		solid state conctat N.O. I _{max} = 150mA V _{max} = 30 Vdc/25Vac Z _{close} < 1 Ω Z _{open} > 1 MΩ	solid state conctat N.C. I _{max} = 50mA V _{max} = 30 Vdc/25Vac Z _{close} < 15 Ω Z _{open} > 1 MΩ
8/AL	Alarm output: - Interrupted load - Line voltage absent - Overtemperature		

Note: The connections are also representative of 90-120A models

Note: For terminals and conductors to be used, see the table: "CLAMP AND CONDUCTOR CHARACTERISTICS TABLE" on page 14

GRS...D-3

GRS...D-5

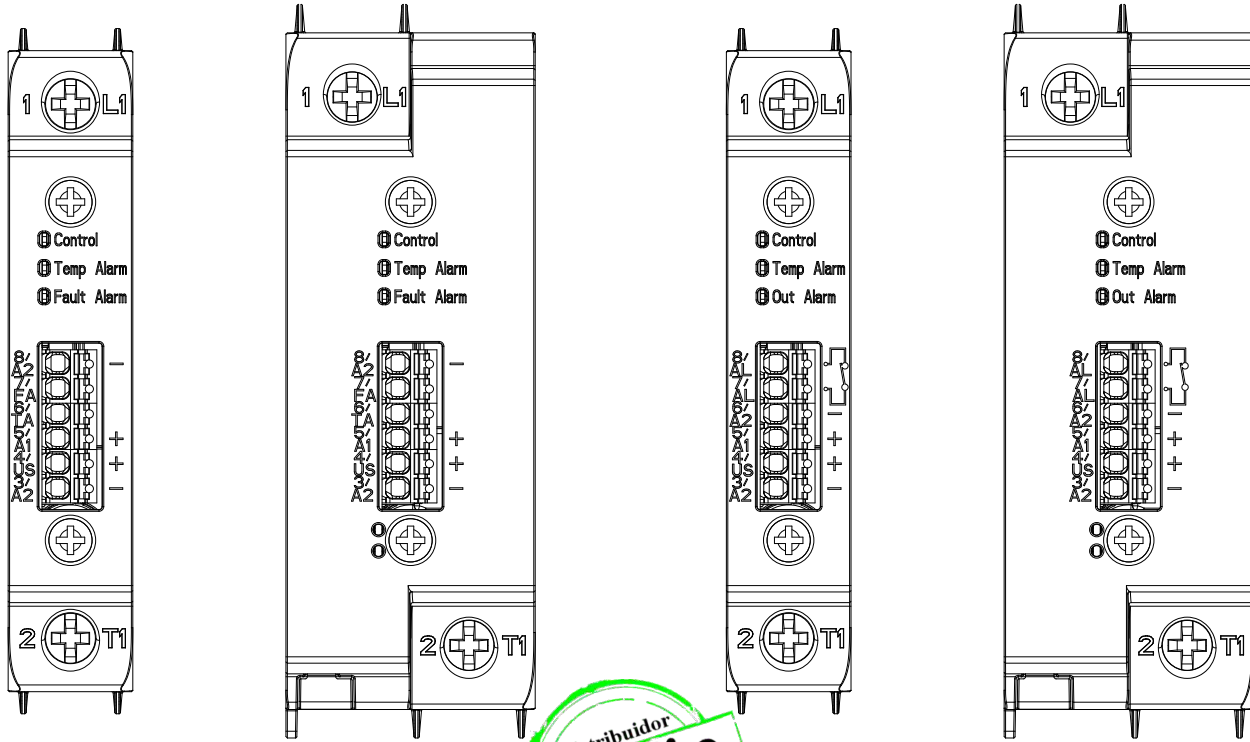

Description of terminal/connector versions with type "D" input

Signal connector version with option type "3" (GRS...D-3) (Overvoltage Category II o III)

Rif.	Description	Notes
3/A2-	GND for power supply and control input ON/OFF	
4/US	+ Vdc power supply	Power supply GRS (Range from 10 to 32 Vdc, I _{max} < 14 mA at 32V)
5/A1+	+Vdc control input ON/OFF	Range: ON da 5,1 a 32Vdc, I _{max} <0,5 mA at 32V OFF < 1,8V
6/TA	Overtemperature alarm output	PNP output normally not active (1) I _{max} =150mA Vout: + V DC power supply -1V
7/FA	Alarm output: interrupted load or line voltage absent	PNP output normally not active (1) I _{max} =150mA Vout: + V DC power supply -1V
8/A2-	GND Control input ON/OFF (common to terminal 3/A2-)	Additional connection to be used only as GND for the control signal

Alarm output connector version with type "5" option (GRS...A-5) (Overvoltage Category II o III)

3/A2-	GND for power supply and control input ON/OFF	
4/Us	+ Vdc power supply	Power supply GRS (Range from 6 to 32 V DC, I _{max} < 14 mA at 32V)
5/A1+	+Vdc control input ON/OFF	Range: ON from 3 to 32Vdc, I _{max} <0,5 mA at 32V OFF < 1,8V
6/A2-	GND Control input ON/OFF (common to terminal 3/A2-)	Additional connection to be used only as GND for the control signal
7/AL	Overtemperature alarm output	Solid state N.C. contact I _{max} = 50mA V _{max} = 30 Vdc/25Vac Z _{closed} < 15 Ω Z _{open} > 1 MΩ
8/AL		

(1): The normally inactive PNP outputs can be connected to each other and obtain a single alarm output

Note: The connections are also representative of 90-120A models

Note : For terminals and conductors to be used, see the table: "CLAMP AND CONDUCTOR CHARACTERISTICS TABLE" on page 14

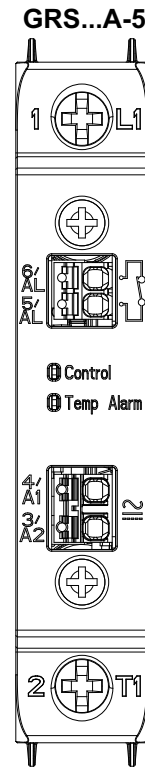
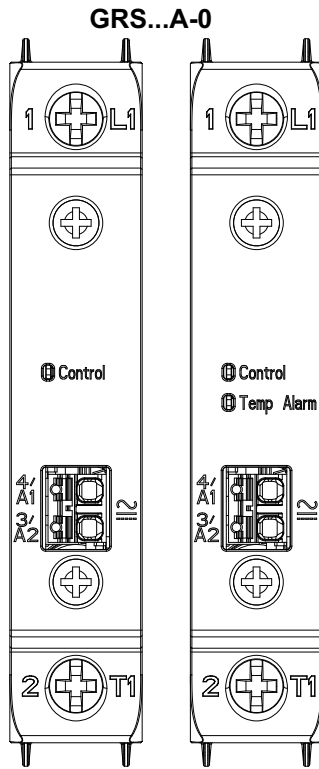

Description of terminal versions with type "A" input

"Power Terminals (common to all versions)" (Overvoltage category III)

Rif.	Description	Notes
1/L1	Line Connection	
2/T1	Load Connection	

"control connector" (Overvoltage Category II)

3/A2	Control input ON/OFF in AC	Vac/Vdc input (Range 20 to 260Vac/Vdc, I _{max} < 8 mA) (Overvoltage Category II)
4/A1		

Alarm output connector version with type "5" option (GRS...A-5) (Overvoltage Category II o III)

5/AL	Overtemperature alarm output	Solid state N.C. contact I _{max} = 150 mA V _{max} = 30 Vdc/25Vac Z _{closed} < 1 Ω Z _{open} > 1 MΩ
6/AL		

Note: The connections are also representative of 90-120A models

Note : For terminals and conductors to be used, see the table: "CLAMP AND CONDUCTOR CHARACTERISTICS TABLE" on page 14

LED STATUS DESCRIPTION

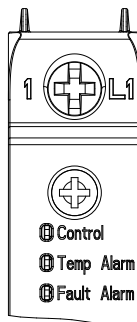

Note:
ON LED is always present,
Temp Alarm and Fault Alarm LEDs are optional

STATUS	LED Control (Green)	LED Temp Alarm (Yellow)	LED Fault Alarm/Out Alarm (Red)
SCR OFF, no alarm	OFF	OFF	OFF
SCR ON, no alarm	ON	OFF	OFF
SCR ON, Alarm output active	ON	OFF	ON
Control signal active, SCR forced off for overtemperature protection	OFF	ON	OFF
Control signal active, SCR forced off for overtemperature protection, Alarm output active	OFF	ON	ON
SCR off, Alarm output active for interrupted load (alarm is stored, Status only possible with GRS with Type D input and options 1/2/3)	OFF	OFF	ON

Logic voltage output command

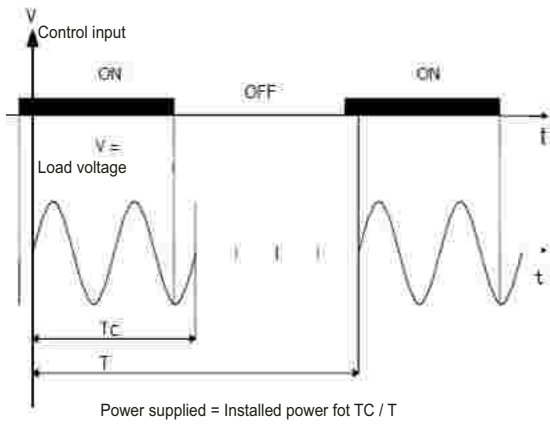

GRS thermal protection

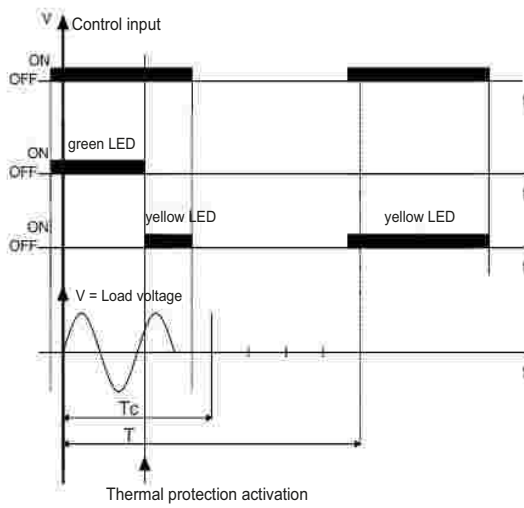

THERMAL ALARM

Models with thermal alarm

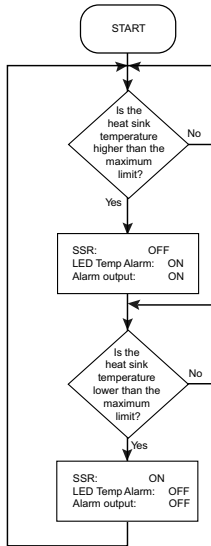

Models with thermal alarm and FAN63 option

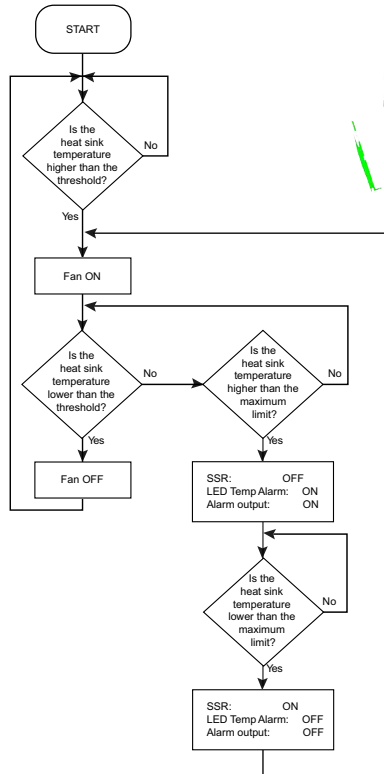

ALARM LOAD INTERRUPTED

GRS with V DC command (Control type "D" with options)

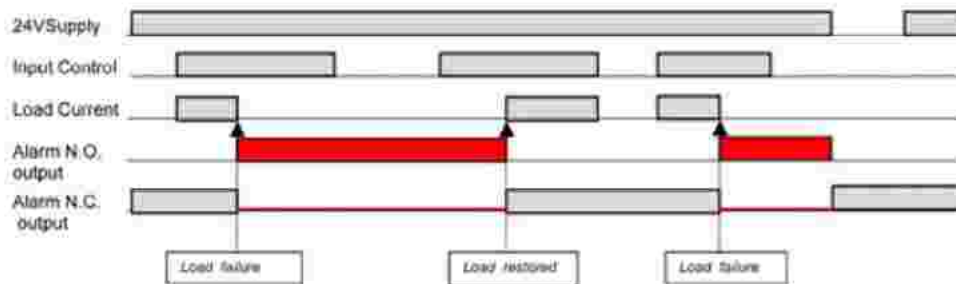

Single-phase connection

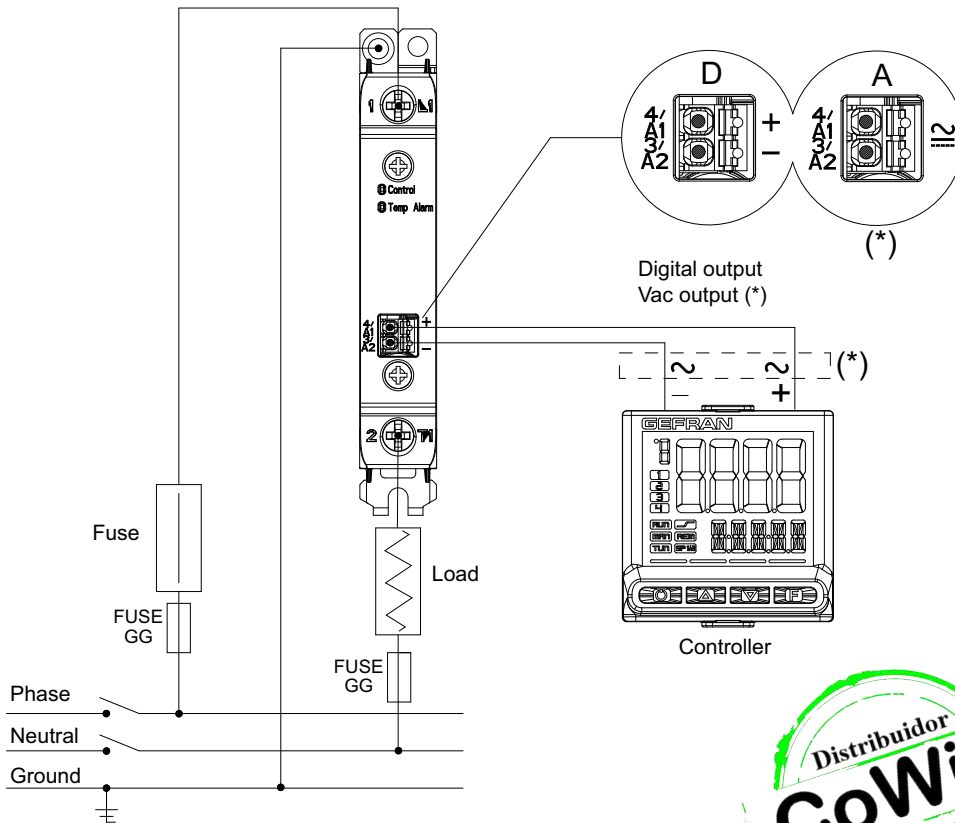

Three-phase Wye connection with neutral

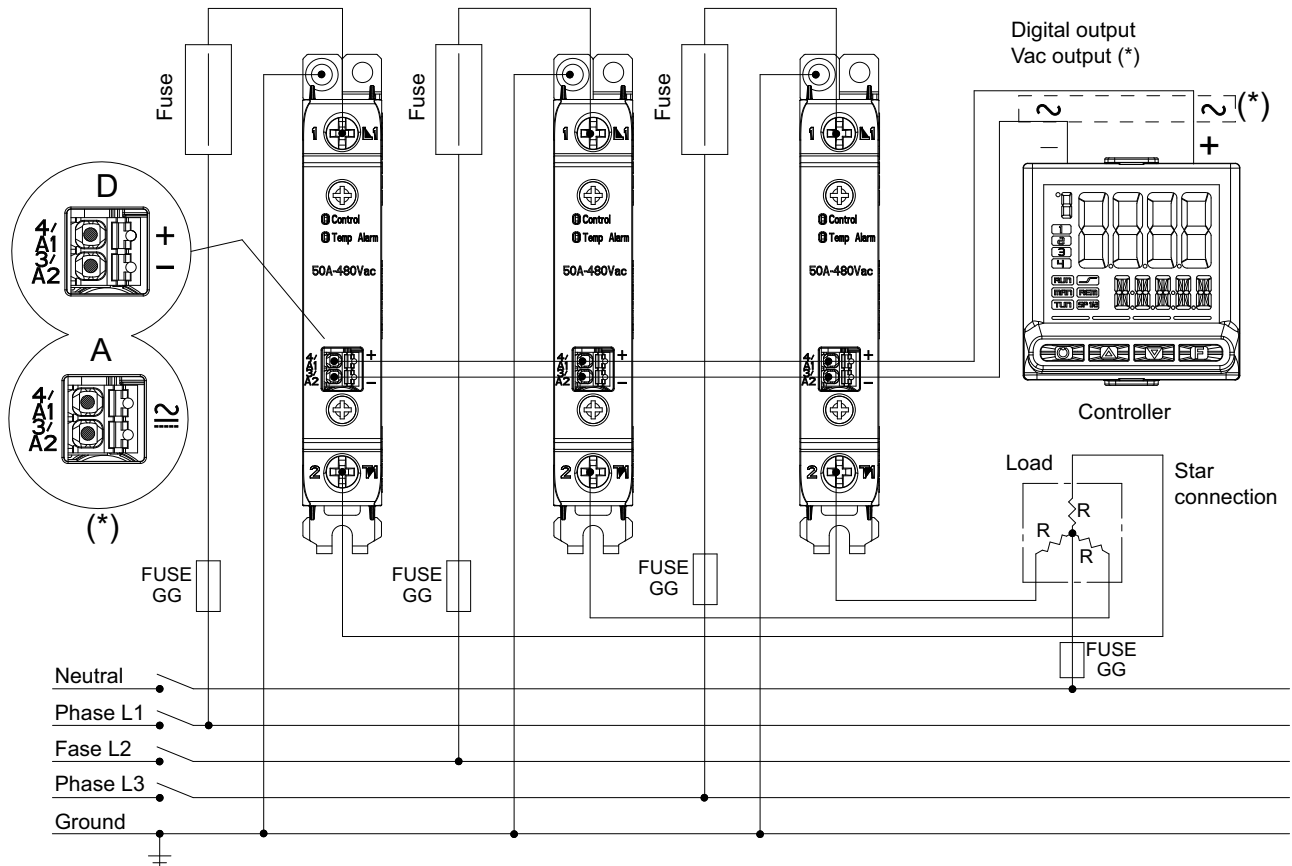

(*) Or relay output with V AC output voltage
(Use GRS with Vdc command input Type "A" input)

Three-phase Triangle or Star connection without neutral on two phases

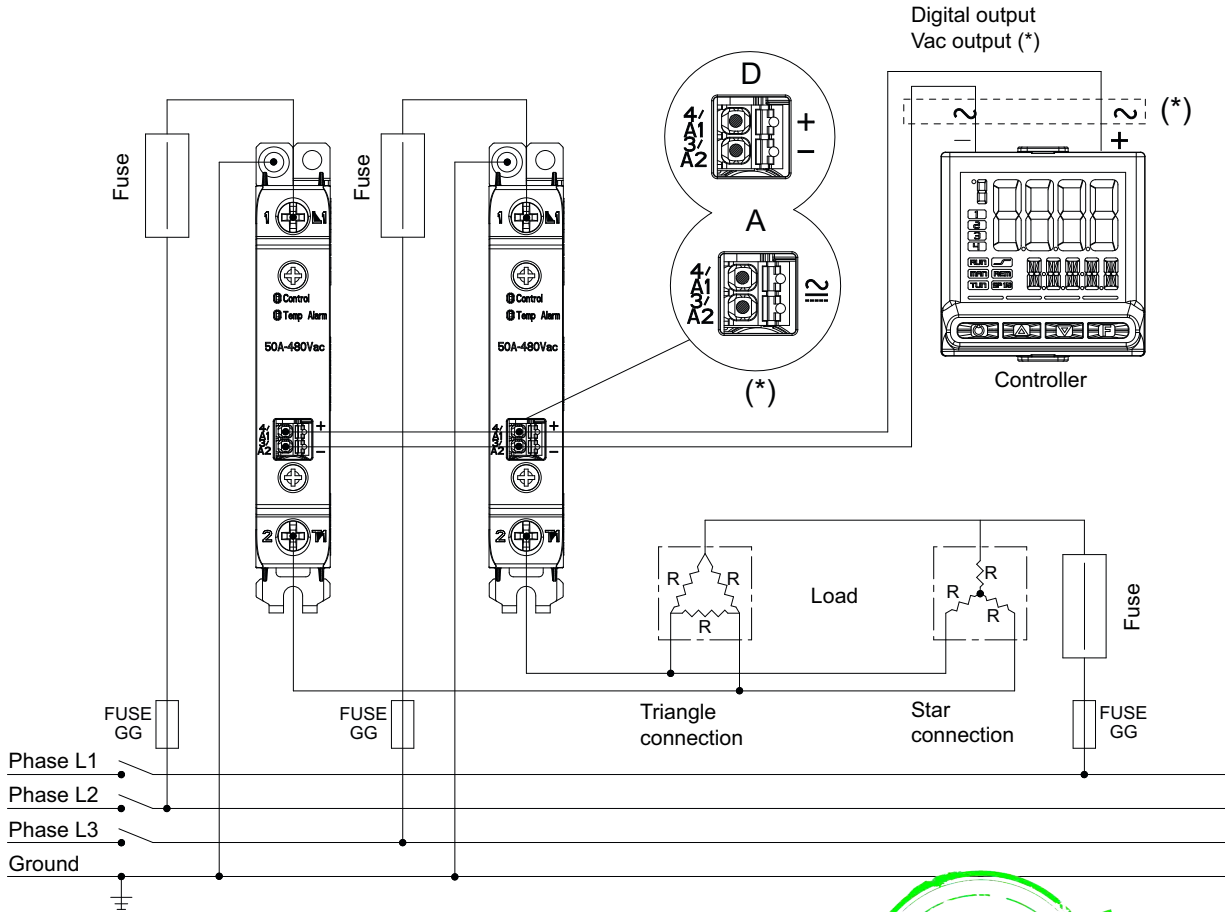

(*) Or relè output with Vac tension
(Use GRS-H with comand input vac type A)



Connection example for GRS-H with VDC ("DD-0" type)

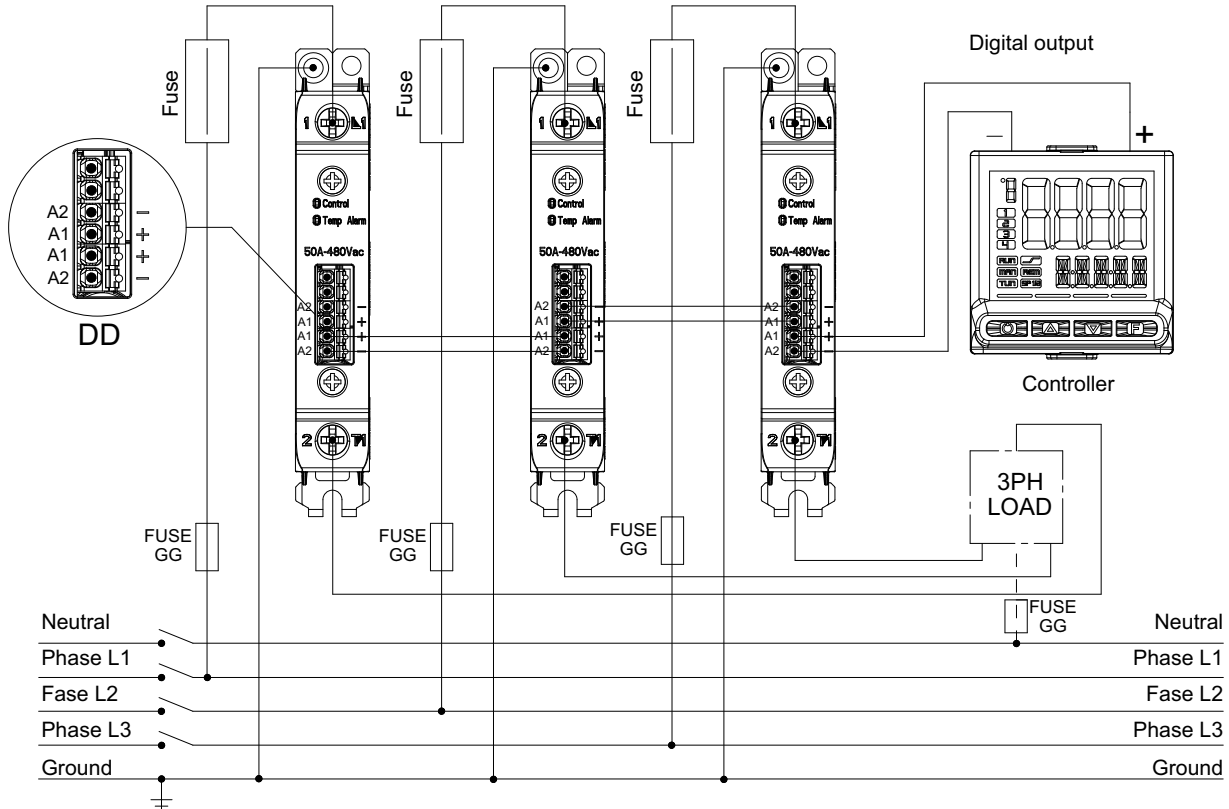

Connection example for GRS with V DC command with isolated contact alarm output option (Options 1 and 2)

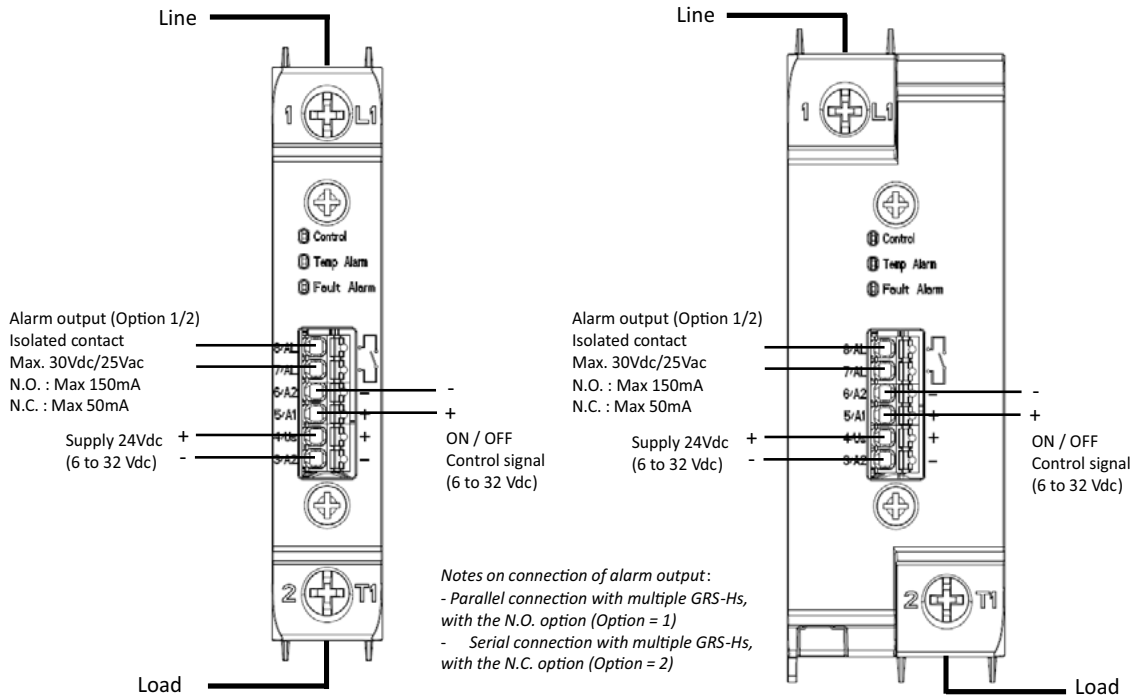

Connection example for GRS with V DC command with PNP alarm output option (Option 3)

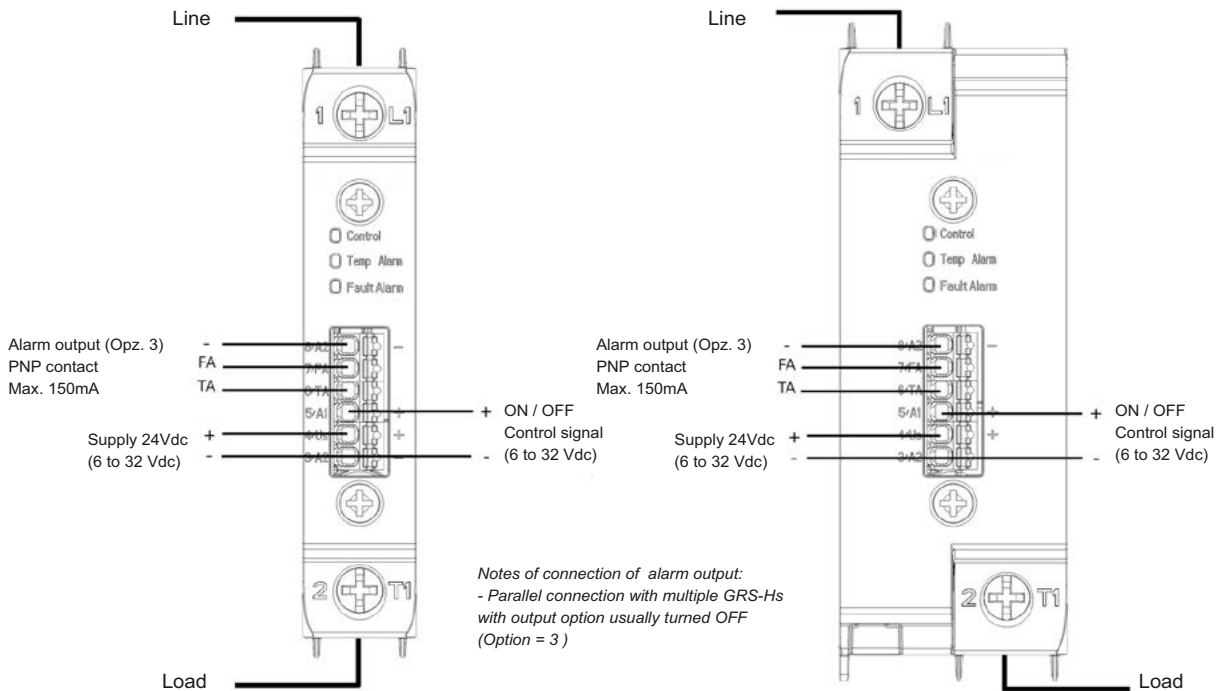

Connection example for GRS with V DC control with thermal alarm option (Option 5)

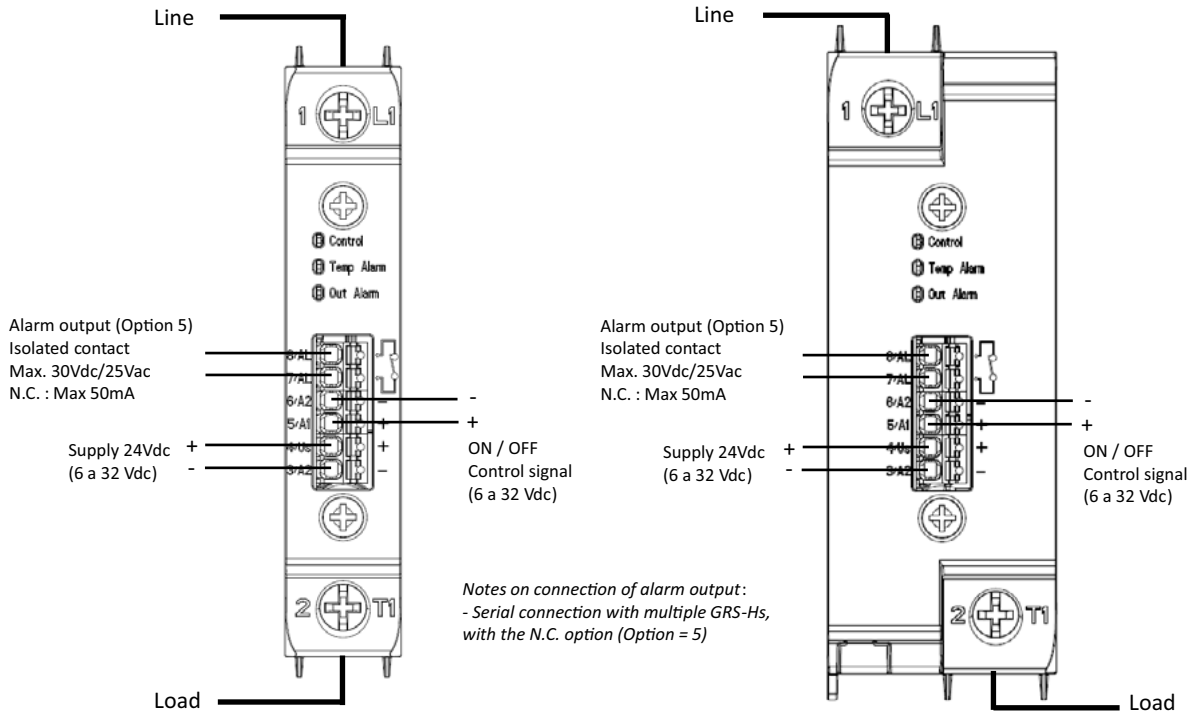

Connection example for GRS with V AC control with thermal alarm option (Option 5)

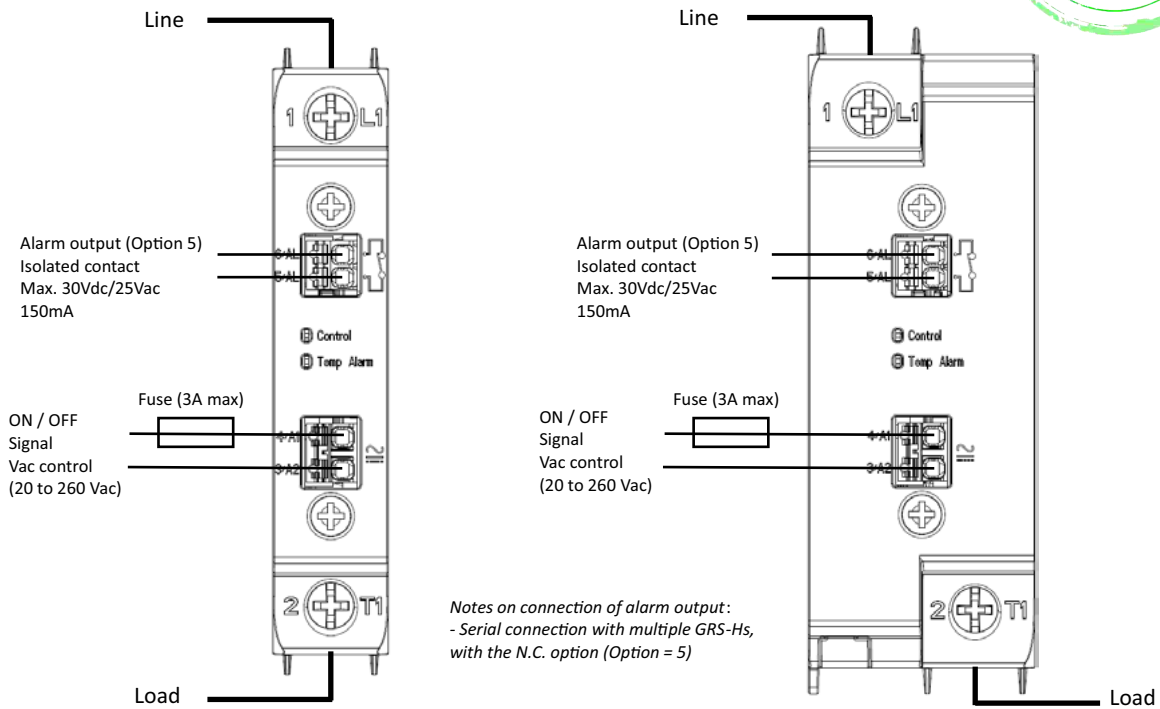

GG FUSES

An electrical protection device known as a GG FUSE must be used to ensure protection against short-circuit of the electrical cable (see EN 60439-1, paragraph 7.5 Short-circuit protection and short-circuit withstand strength" and 7.6 "Switching devices and components installed in ASSEMBLIES", or the equivalent paragraphs of standard EN 61439-1).

ROTECTION WITH MCB

Protection co-ordination (Type 2) with Siemens Miniature Circuit Breaker (MCB / Thermal-Magnetic) 5SY4 series, curve A, 1P and 2P							
Current size model (I ² t)	1P MCB model (MCB Nominal current in A) at 230Vac *	Wire cross sectional area (mm ²)	Minimum length ***of copper wire conductor (m)	2P MCB model (MCB Nominal current in A) at 400Vac **	Wire cross sectional area (mm ²)	Minimum length ***of copper wire conductor (m)	
GRS(-H)-15,25,30,40 (1800 A ² s)	5SY4110-5 (10)	1,0	6,0	5SY4210-5 (10)	1,0	6,0	
		1,5	9,0		1,5	10,0	
		2,5	14,0		2,5	14,0	
	5SY4116-5 (16)	1,0	6,0	5SY4216-5 (16)	1,0	6,0	
		1,5	9,0		1,5	10,0	
		2,5	14,0		2,5	14,0	
		4,0	15,0		4,0	25,0	
	5SY4120-5 (20)	1,5	9,0	5SY4220-5 (20)	1,5	10,0	
		2,5	15,0		2,5	21,0	
		4,0	30,0		4,0	30,0	
	5SY4125-5 (25)	2,5	18,0	5SY4225-5 (25)	2,5	18,0	
		4,0	30,0		4,0	30,0	
	5SY4132-5 (32)	2,5	21,0	5SY4232-5 (32)	2,5	36,0	
		4,0	35,0		-	-	
	GRS(-H)-25I, 30I, 50, 60,75 (12800 A ² s)	For MCBs smaller than those indicated in the lines below, there are no section and length constraints.					
5SY4132-5 (32)		2,5	2,0	5SY4232-5 (32)	2,5	2,0	
		4,0	4,0		4,0	4,0	
		6,0	7,0		6,0	7,0	
5SY4140-5 (40)		4,0	4,0	5SY4240-5 (40)	4,0	4,0	
		6,0	7,0		6,0	7,0	
		10,0	10,0		10,0	10,0	
5SY4150-5 (50)		6,0	7,0	5SY4250-5 (50)	6,0	7,0	
		10,0	10,0		10,0	10,0	
		16,0	18,0		16,0	18,0	
5SY4163-5 (63)		6,0	7,0	5SY4263-5 (63)	6,0	7,0	
		10,0	10,0		10,0	10,0	
		16,0	18,0		16,0	18,0	
GRS(-H)-90,120 (11250 A ² s)		For MCBs smaller than those indicated in the lines below, there are no section and length constraints					
		5SY4132-5 (32)	2,5	2,0	5SY4232-5 (32)	2,5	2,0
	4,0		4,0	4,0		4,0	
	6,0		7,0	6,0		7,0	
	5SY4140-5 (40)	4,0	4,0	5SY4240-5 (40)	4,0	4,0	
		6,0	7,0		6,0	7,0	
		10,0	10,0		10,0	10,0	
	5SY4150-5 (50)	6,0	7,0	5SY4250-5 (50)	6,0	7,0	
		10,0	10,0		10,0	10,0	
		16,0	18,0		16,0	18,0	
	5SY4163-5 (63)	6,0	7,0	5SY4263-5 (63)	6,0	7,0	
		10,0	10,0		10,0	10,0	
		16,0	18,0		16,0	18,0	

* The sizing is valid for a 230Vac phase-neutral line with an assumed short-circuit current of 2,5KA

** The sizing is valid for a 400Vac phase-to-phase line with an assumed short-circuit current of 5KA

*** Between MCB and Load plus return path which goes back to the lines/neutral

Example, for a GRS-50- ..., with line voltage of 230Vac, controlled load of 45 A nominal, with a section of 6mm² of cable, an MCB 5SY4150-5 (50 A) the minimum length of the cables is 7m (cable length is intended between MCB and load, including return).



TABLE OF TERMINALS AND CONDUCTORS

POWER TERMINALS		
GRS(-H) Rating current	15-25-30-40-50-60-75	90-120
Wiring type	Rigid / flexible / ferrule conductor	
Contact area (WxD) screw type	9,2 x 8 mm M5	10,5 x 10,7 mm M5
Stripping length	11 mm	13 mm
Minimum allowed section 1 Conductor / 2 Conductors	1 x 0.75 mm ² / 2 x 0.75 mm ² 1 x 18 AWG / 2 x 18 AWG	
Maximum allowed section 1 Conductor / 2 Conductors	1 x 25 mm ² / 2 x 16 mm ²	1 x 50 mm ² / 2 x 25 mm ²
	1 x 3 AWG / 2 x 6 AWG	1 x 1/0 AWG / 2 x 3 AWG
Tightening torque	2,5-3 Nm (22-26,6lb-in)	
Note: Use 75°C (167°F) copper (CU), multi-stranded conductors		

CONTROL/SIGNAL TERMINALS	
Rigid / flexible / cable lug conductor cross section	
1 Conductor section 2 Conductors section	1 x 0.2-1.5 mm ² / 2 x 0.1-0.75 mm ²
	1 x 24-15 AWG 2 x 27-18 AWG
Stripping length / cable lug	1x 8-10 mm 2x 10-12 mm
Note: Use 60/75°C (140/167°F), solid or multi-strand copper (CU) conductors	



Nota:
 For Canadian end-use applications only, an R/C VZCA/7 (or CSA-approved) surge protector is required to be installed in the end-use as shown below:
 - Maximum clamping voltage 800V, for the control input of Type "D"/"DD" devices.
 - Maximum clamping voltage 2500V, for control input of "A" type devices.
 - Maximum clamping voltage 800V, for the auxiliary output of type "D"/"DD" and "A" devices.

PROTECTION FUSES

Type 1 and Type 2 coordination are ratings based on the level of protection and resilience provided during a high current fault. Device is designed to protect people and equipment during a short circuit fault,, but the differences between the two levels can be explained as follows:
 Type 1 : after a short circuit event it may be too damaged for further use.
 Type 2 : after a short circuit event device will still be in working.

Protection co-ordination (Type 2)

Size device	Fuse nominal Current	Model and fuse size (manufacturer Bussmann Div Cooper (UK) Ltd)	Fuse code (descr.)	Fuse holder accessory code (descr.)
15	16	FWC-16A10F 10x38	338470 (FUS-016)	337132 (PF-10x38)
25,25I	25	FWC-25A10F 10x38	338474 (FUS-025)	
30,30I	32	FWC-32A10F 10x38	338483 (FUS-032)	
40	40	FWP-40A14F 14x51	338147 (FUS-040)	337131 (PF-14x51)
50	50	FWP-50A14F 14x51	338079 (FUS-051)	
60	63	FWP-63A22F 22x58	338191 (FUS-063)	337130 (PF-22x58)
75	80	FWP-80A22F 22x58	338199 (FUS-080)	
90	100	FWP100A22F 22x58	338478 (FUS-100)	
120	125	170M1418 000-TN/80	338106 (FUS-100)	337092 (PF-DIN)

Protection co-ordination (Type 1) according to UL 508

The devices are suitable For Use On A Circuit Capable Of Delivering Not More Than 100,000 A rms Symmetrical Amperes, 600 Volts Maximum when Protected by UL Listed fuses with size and class as specified in the table below:

Size device	Fuse Class	Fuse Current Max Size [A]	Prospective short circuit current [kArms]
15, 25 , 30	J	40	100
	CC	30	
40	J	40	
25I		80	
30I		80	
50		80	
60		80	
75		80	
90		125	
120		125	

Use Fuses Only.

FANS (for 90A/120A models only)

Model		Code	Type
90A	FAN60	363484	230 Vac 60mm x 60mm x 30mm for 90A models
120A		363011	230Vac 80mm x 80mm x 38 mm for 120A models
90A	FAN61	363485	115Vac 60mm x 60mm x 30 mm for 90A models
120A		363003	115Vac 80mm x 80mm x 38 mm for 120A models
	FAN62	363037	24 Vdc 60mm x 60mm x 25mm

ORDER CODE

GRS - [] - [] - [] - [] - 0 - 0 - 0

Rated current	
15Aac	15
25Aac	25
25Aac I2t++	25I
30Aca	30
30Aac I2t++	30I
40Aac	40
50Aac	50
60Aac	60
75Aac	75
90Aac	90
120Aac	120

Rated voltage	V
480Vac	48
600Vac	60

Input type	
6 ... 32 Vdc	D
6..32 Vdc Double Input	DD
20 ... 260 Vac / Vdc	A

Future developments	
0	None

Control terminal	
0	Push In

OPTIONS	
0	None
1	Thermal alarm and load interrupted Insulated contact (NO) (1)
2	Thermal alarm and load interrupted Insulated contact (NC) (1)
3	Thermal alarm and load interrupted Digital output PNP (NO) (1)
5	Thermal alarm Insulated contact (NC)



Notes:

Available solo per version with type D, non DD



WARNING: this symbol indicates danger.

Read the following warnings before installing, connecting or using the device:

- follow instructions precisely when connecting the device.
- always use cables that are suitable for the voltage and current levels indicated in the technical specifications.
- In applications with risk of damage to persons, machines or materials, you **MUST** install auxiliary alarm devices. It is advisable to verify frequently that the alarm device is functional even during the normal operation of the equipment.
- **DO NOT** operate the device in rooms with dangerous (flammable or explosive) atmosphere.
- During continuous operation, the heat sink can reach up to 100°C, and stays at a high temperature even after the device is turned off due to thermal inertia; therefore, **DO NOT** touch it and avoid contact with electrical wires.
- do not work on the power part without first disconnecting electrical power to the panel.
- do not remove the cover when the device is powered!

Installation:

- correctly ground the device using the specific terminal.
- power supply lines must be separated from device input and output lines; always check that the supply voltage matches the voltage indicated on the device label.
- avoid dust, humidity, corrosive gases and heat sources.
- respect the installation distances between one device and another (to allow for dissipation of generated heat).
- to keep air in movement, we advise you to install a fan near the GRS group in the electrical panel containing the GRSs.





Maintenance: at regular intervals, check operation of the cooling fans and clean all air ventilation filters.

- repairs must be done out only by trained and specialized personnel. Cut power to the device before accessing internal parts.
- do not clean the box with solvents derived from hydrocarbons (trichloroethylene, gasoline, etc.). Using such solvents will compromise the device's mechanical reliability. Use a clean cloth moistened with ethyl alcohol or water to clean external parts in plastic.

Service: GEFTRAN has a service department. The warranty excludes defects caused by any use not conforming to these instructions.

GEFRAN spa reserves the right to make aesthetic or functional changes at any time and without notice.



	This device conforms to European Union Directive 2014/30/EU and 2014/35/EU as amended with reference to generic standards: EN 61000-6-2 (immunity in industrial environment) EN 61000-6-4 (emission in industrial environment) - EN 61010-1 (safety regulations).
	Conformity TC RU C-IT.AJ132.B.00422
	Conformity UL508 - File: E243386
	Short Circuit Current Rating 100KA / 600V according to UL 508