



WHOLE HOME CARBON FILTER

INSTALLATION GUIDE &
OWNER'S MANUAL

FOR MODELS

- IC-1044
- IC-1054
- IC-1354

YOUR SYSTEM:

Installation Date: _____

Installer: _____

City/State: _____

Phone: _____

Model: _____

Serial #: _____

YOUR WATER RESULTS:

Total Hardness: _____ gpg

Iron (Fe): _____ ppm

Acidity (pH): _____

Total Dissolved Solids (TDS): _____ ppm

Total Compensated Hardness: _____ gpg

INSTALLATION CHECKLIST

Plumbing Connections— All plumbing materials and the installation must adhere to State and Local Plumbing Codes. Please see the warning on Page 3 for additional considerations when installing into a copper or galvanized steel plumbing system.

Water Pressure— Proper operation of the equipment requires:

- A minimum of 25 pounds water pressure.
- A maximum of 100 pounds water pressure.
- A minimum flow rate of 3 gallons per minute.

Temperature— Equipment must not be installed where it will be exposed to temperatures below 40° F or above 100° F.

Bypass Valve— The system includes a bypass valve. If the existing plumbing already has a bypass, the one provided may be removed. If you used the bypass provided, a full port ball valve should be installed on the inlet side. The equipment is designed to accommodate minor plumbing misalignments, but is not able to support the weight of the system or plumbing.

INSTALLATION PROCESS

- 1. System Location**— Place the scale reduction tank in the desired location. Ensure the area has a smooth, level surface and will not experience freezing temperatures.
- 2. Attached Bypass**— Connect the bypass valve provided to the 1" openings on the top of the media tank.
- 3. Connect Inlet**— Plumb the cold water supply from the water source to the inlet port of the bypass valve.
- 4. Start Up Instructions**—
 - Place a bucket under the outlet port of the bypass valve or run a temporary line from the outlet to a drain until the water runs clear.
 - **Slowly** open the inlet valve to the Fill Position shown on Page 4. Allow the tank to fill with water until a steady stream of water comes out of the outlet port.
 - **Close** the inlet side of the bypass to stop the flow of water.
 - Connect the outlet port of the bypass valve to the cold water line that supplies the building.
 - Fully open the inlet valve of the bypass. The unit is now providing conditioned water to the building.
 - Open faucets downstream from the system to release any air in the lines.
 - Be sure to check for any leaks and repair before completion.

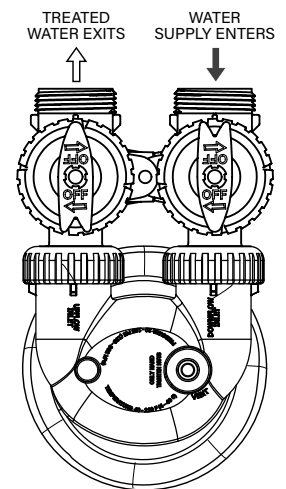

INSTALLATION DIAGRAM

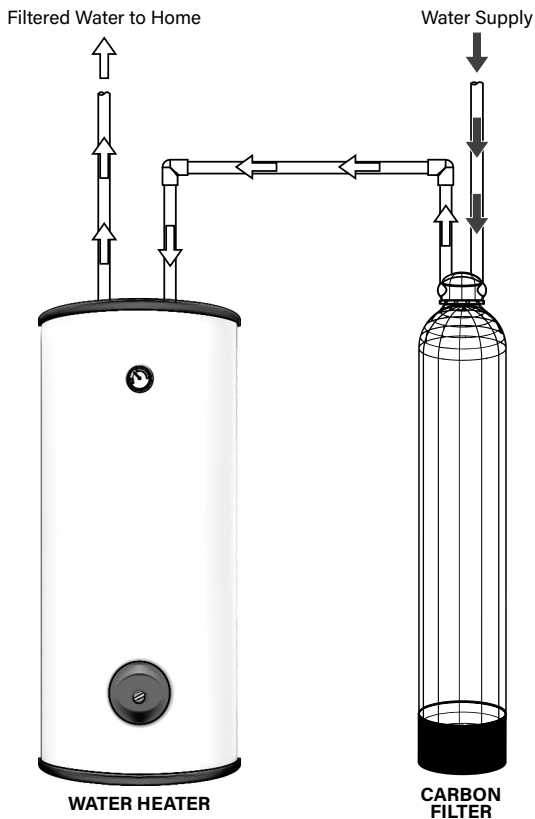

WARNING— Please be aware that some homes may have been constructed to building codes that encouraged the grounding of electrical appliances to the plumbing system. If this system will be installed in a copper, galvanized steel, or metal (conductive) plumbing system, the plastic components of the system will interrupt the electrical continuity of the plumbing system.

This will result in any stray currents from improperly grounded appliances downstream or potential galvanic activity to no longer be grounded. A grounded "jumper wire" bridging the equipment and reestablishing the contiguous conductive nature of the plumbing system needs to be installed prior to your systems use.

A simple ground jumper wire and pipe clamp can be purchased at any hardware store.

SPECIFICATIONS

CARBON FILTER CAPABILITIES			
Model:	IC-1044	IC-1054	IC-1354
Media Included (Cu. Ft.)	Granular Activated Carbon 1.0	Granular Activated Carbon 1.3	Granular Activated Carbon 2.0
Gravel (Lbs.)	15	20	25
pH Range	7.0 (or greater)	7.0 (or greater)	7.0 (or greater)
Max. Service Flow (GPM)	4	5	7
Min.-Max. Operating Pressure (PSI)	25-100	25-100	25-100
Min.-Max. Operating Temp. (°F)	40-100	40-100	40-100
Plumbing Size:	1"	1"	1"
Total Dimensions:			
• Valve & Media Tank (Width x Height)	10"x46.5"	10"x56.5"	13"x56.5"
• Inlet/Outlet Width	3"	3"	3"

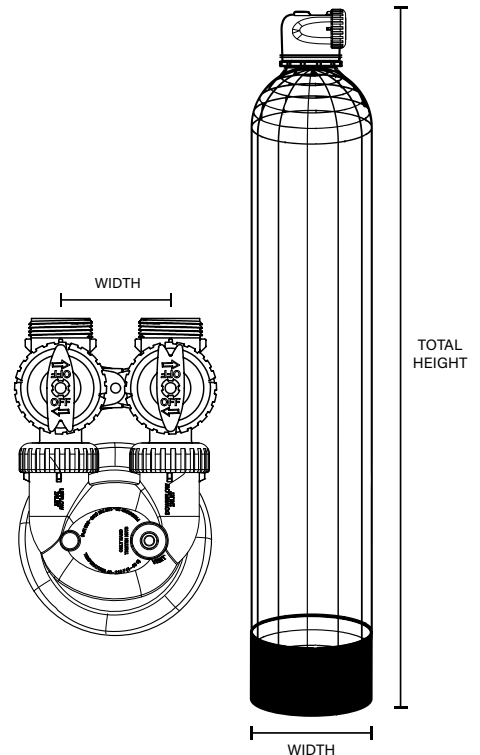

PRODUCT WARRANTY

In the unlikely event that your system has defects in material or assembly, the manufacturer will proudly stand behind our products and support the original owner for:

5 YEARS
on Mineral Tank

5 Years
on All Parts

System must be installed in accordance with specifications outlined in this manual and local plumbing codes to qualify for the factory warranty. Warranty coverage is limited and will not cover damaged due to accident, fire, flood, freezing, any other "Act of God," change in water conditions, misapplication, neglect, vacuum, lack of maintenance, or equipment installed on a non-potable water source.

Periodic media replacement based on water usage is necessary to maintain longterm effectiveness.

BYPASS VALVE OPERATION

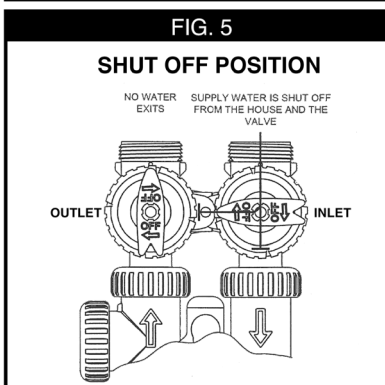
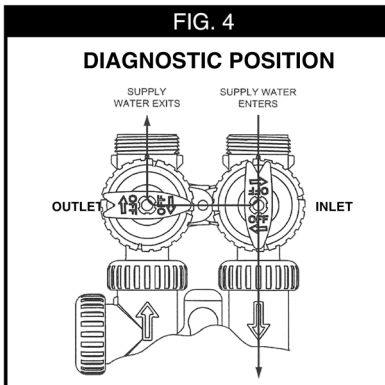
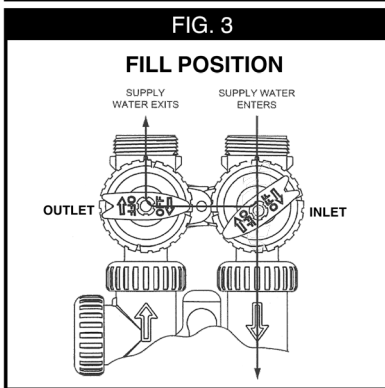
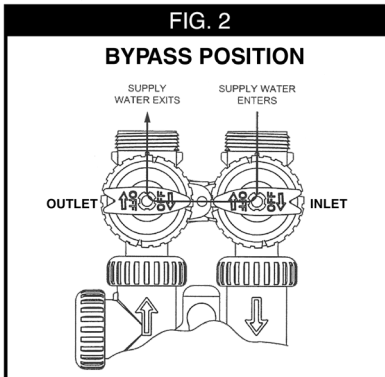
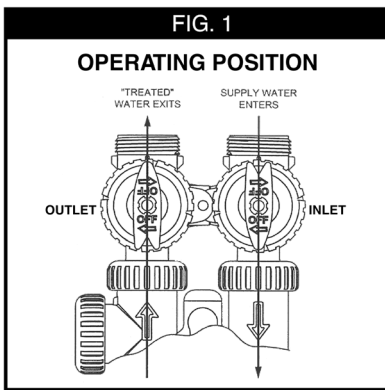

The bypass valve is used to isolate the system's operation from the plumbing system's water pressure in order to perform repairs or maintenance. The bypass provided with your water system is uniquely designed to be versatile with many advanced features. The 1" full flow valve incorporates four positions, including a diagnostic position that allows service personnel to work on a pressurized system while still providing untreated water to the building. It's completely non-metallic design allows for easy serviceability without the needs for tools.

The bypass body and rotors are glass-filled Noryl while the nuts and caps are glass-filled polypropylene. All seals are self-lubricating EPDM to help prevent seizing after long periods of non-use. Internal O-rings can easily be replaced if maintenance is required.

The bypass consists of two interchangeable plug valves that are operated independently by red arrow-shaped handles. The handles will point in the direction of the water flow in any given position. The plug valves enable the bypass valve to operate in multiple positions. See diagrams for details.

- 1. Normal Operating Position—** Inlet handle is turned to have the arrow pointing toward the unit. Water flows through the control valve during normal operation. This position also allows the control valve to isolate the media bed during the regeneration cycle. The outlet handle is pointed away from the unit to allow the flow of treated water to leave the system and enter the building's plumbing system. (See Fig. 1)
- 2. Bypass Position—** The inlet and outlet handles point towards each other. This isolates the control valve from the water pressure contained in the plumbing system. Any water drawn from the building while the system is in this position will receive untreated water directly from the source. (See Fig. 2)
- 3. Fill Position—** During initial start up, the media tank will need to be filled with water. Slowly open the inlet handle to be partially open; handle arrow should point at a 30°-45° angle from the closed position. The outlet handle should remain closed, pointing toward the center of the bypass. (See Fig. 3)
- 4. Diagnostic Position—** The inlet handle arrow points toward the unit to allow water pressure to flow into the control valve. The outlet handle remains closed, pointed toward the center of the bypass. (See Fig. 4) This is helpful to have water run through the system without it affecting the rest of the building.
- 5. Shut Off Position—** The inlet handle is closed with the arrow pointing toward the center of the bypass. The outlet handle should point away from the unit. (See Fig. 5) This will stop all water flow to the building. If water is still available to the plumbing system in this position, a plumbing connection somewhere that is going around the unit.