



1"-2" COMMERCIAL WATER SOFTENER

INSTALLATION GUIDE &
OWNER'S MANUAL

FOR TS SERIES

INDEX

Valve Settings— For Users	3
Bypass Valve Operation	4
Bypass Diagrams for 1" & 1.25" Valves	
Installation Instructions	5
Pre-Installation Checklist	
Installation Diagrams	
Post-Installation Checklist	
Valve Settings— For Installers	6
Operation and Maintenance	8
Error Codes and In-Field Resolution Guide	10
Replacement Parts	13

YOUR SYSTEM:

Installation Date: _____

Installer: _____

City/State: _____

Phone: _____

Model: _____

Serial #: _____

YOUR WATER RESULTS:

Total Hardness: _____ gpg

Iron (Fe): _____ ppm

Acidity (pH): _____

Total Dissolved
Solids (TDS): _____ ppm

Total Compensated
Hardness: _____ gpg

PRODUCT WARRANTY

In the unlikely event that your system has defects in material or assembly, the manufacturer will proudly stand behind our products and support the original owner for the following:

5 YEARS
on Mineral Tank

5 YEARS
on Brine Tank

5 Years
on All Parts

1 Year
on All Other Components

System must be installed in accordance with specifications outlined in this manual and local plumbing codes to qualify for the factory warranty. Warranty coverage is limited and will not cover damaged due to accident, fire, flood, freezing, any other "Act of God," change in water conditions, misapplication, neglect, vacuum, lack of maintenance, or equipment installed on a non-potable water source.

VALVE SETTINGS— USER

DISPLAY SETTINGS

When the system is operating, the screen will scroll between the following displays. Press **NEXT** to pause on the current display for 5 minutes. Continue to press **NEXT** to alternate between displays:

- **Current Time of Day Screen**— Be sure this is accurate for proper operation of the system.
- **Days Remaining**— Number of days left before the system regenerates.
- **Capacity Remaining**— Volume of water that will be treated before the system regenerates. Press ∇ button while on the Capacity Remaining display to decrease the volume in 10 gallon increments.
- **Flow Indicator**— If a water meter is installed, the flow indicator flashes on the display to show the rate at which water is flowing through the system.
- **Flow Rate**— Show the current speed treated water is flowing through the system in gallons per minute.

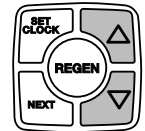
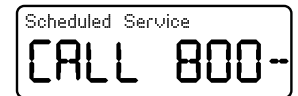
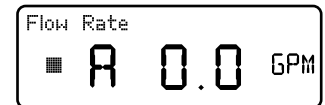
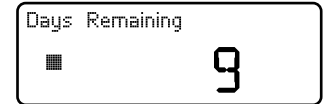
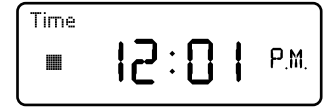

SERVICE REMINDER

Regular maintenance will prolong the life of your system. The unit will let you know when it's time to schedule a check-up. To clear this reminder, press the Δ and ∇ buttons together while the scrolling message is displayed.

SET TIME OF DAY

Besides the initial start up, time of day should only need to be set if the battery has been depleted due of extended power outages or for daylight saving time. If an extended power outage occurs, the time of day will flash, which indicates the time of day should be reset and the non-rechargeable battery replaced.

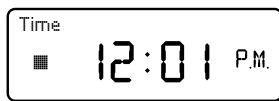

- 1. Access Time of Day**— Press **SET CLOCK**.

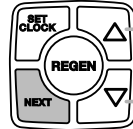

- 2. Set Hour**— Use the Δ or ∇ button to select the current hours of the day. The AM/PM designation will change as you scroll past 12. Press **NEXT**.

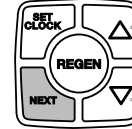

- 3. Set Minutes**— Use the Δ or ∇ button to select the current minute of the hour. Press **NEXT** to exit the Time of Day settings. — or — Press **REGEN** to return to previous step.

Return to operating display screens

SALT ALARM

If the Salt Level Alarm was set, the remaining salt level will be displayed. When the salt remaining has gone below the set point, the display will show CHECK SALT LEVEL.

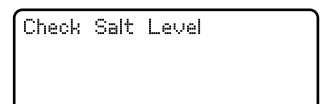
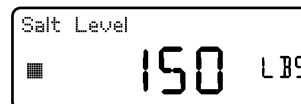

RESET SALT LEVEL

- 1. On the Check Salt Level Screen**— Press **SET CLOCK**.
- 2. Set Salt Pounds**— Use the Δ or ∇ button to set pounds of salt (Range: 0-400 lbs).

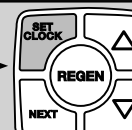
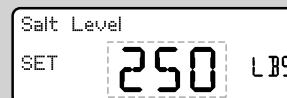
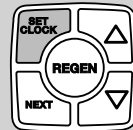
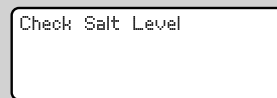

Return to operating display screens

BYPASS VALVE OPERATION

INTEGRATED BYPASS ONLY AVAILABLE ON 1"-1.25" VALVES

The bypass valve is used to isolate the system's operation from the plumbing system's water pressure in order to perform repairs or maintenance. The bypass provided with your water system is uniquely designed to be versatile with many advanced features. The 1" full flow valve incorporates four positions, including a diagnostic position that allows service personnel to work on a pressurized system while still providing untreated water to the building. It's completely non-metallic design allows for easy serviceability without the needs for tools.

The bypass body and rotors are glass-filled Noryl while the nuts and caps are glass-filled polypropylene. All seals are self-lubricating EPDM to help prevent seizing after long periods of non-use. Internal O-rings can easily be replaced if maintenance is required.

The bypass consists of two interchangeable plug valves that are operated independently by red arrow-shaped handles. The handles will point in the direction of the water flow in any given position. The plug valves enable the bypass valve to operate in multiple positions. See diagrams for details.

1. Normal Operating Position— Inlet handle is turned to have the arrow pointing toward the unit. Water flows through the control valve during normal operation. This position also allows the control valve to isolate the media bed during the regeneration cycle. The outlet handle is pointed away from the unit to allow the flow of treated water to leave the system and enter the building's plumbing system. (See Fig. 1)

2. Bypass Position— The inlet and outlet handles point towards each other. This isolates the control valve from the water pressure contained in the plumbing system. Any water drawn from the building while the system is in this position will receive untreated water directly from the source. (See Fig. 2)

3. Fill Position— During initial start up, the media tank will need to be filled with water. Slowly open the inlet handle to be partially open; handle arrow should point at a 30°-45° angle from the closed position. The outlet handle should remain closed, pointing toward the center of the bypass. (See Fig. 3)

4. Diagnostic Position— The inlet handle arrow points toward the unit to allow water pressure to flow into the control valve. The outlet handle remains closed, pointed toward the center of the bypass. (See Fig. 4)
This is helpful to have water run through the system without it affecting the rest of the building.

5. Shut Off Position— The inlet handle is closed with the arrow pointing toward the center of the bypass. The outlet handle should point away from the unit. (See Fig. 5) This stops all water flow to the building. If water is still available to the plumbing system in this position, this indicates a plumbing connection somewhere that is going around the unit.

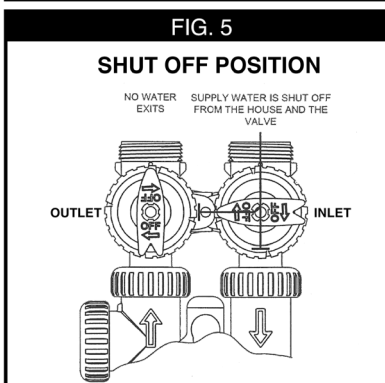
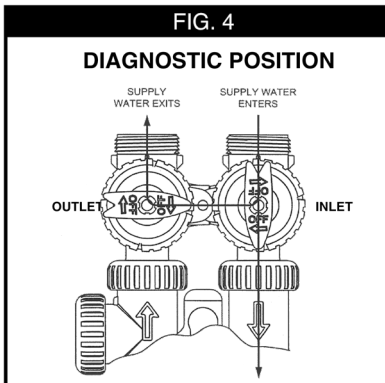
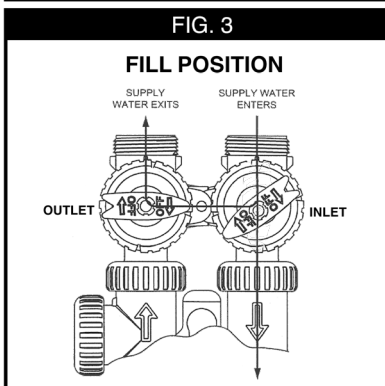
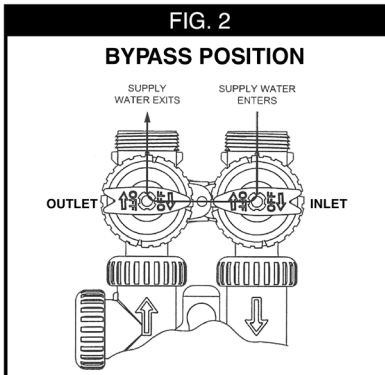
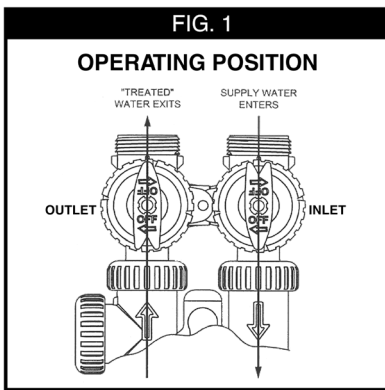

INSTALLATION INSTRUCTIONS

PRE-INSTALLATION CHECKLIST

Plumbing Connections— All plumbing materials and the installation must adhere to State and Local Plumbing Codes.

Water Pressure— Proper operation of the equipment requires:

- A minimum of 25 pounds water pressure.
- A maximum of 100 pounds water pressure.
- A minimum flow rate of 3 gallons per minute.

Electrical Requirements— A continuous 110 volt 60 hertz AC current is needed for power supply. Ensure power is not on a switched outlet or interrupted in any other way.

Temperature— Equipment must not be installed where it will be exposed to temperatures below 40° F or above 100° F.

Drainage Information— The unit should be installed as close to the drain and water supply as possible. The connections for inlet and outlet will vary depending on the style of valve. Ensure you have the proper diameter for the unit. Construct the drain outlet to include an air gap of at least 2 pipe diameters.

Bypass Valve— The system includes a bypass valve. If the existing plumbing already has a bypass, the one provided may be removed. If you used the bypass provided, a full port ball valve should be installed on the inlet side. The equipment is designed to accommodate minor plumbing misalignments, but is not able to support the weight of the system or plumbing.

INSTALLATION DIAGRAM

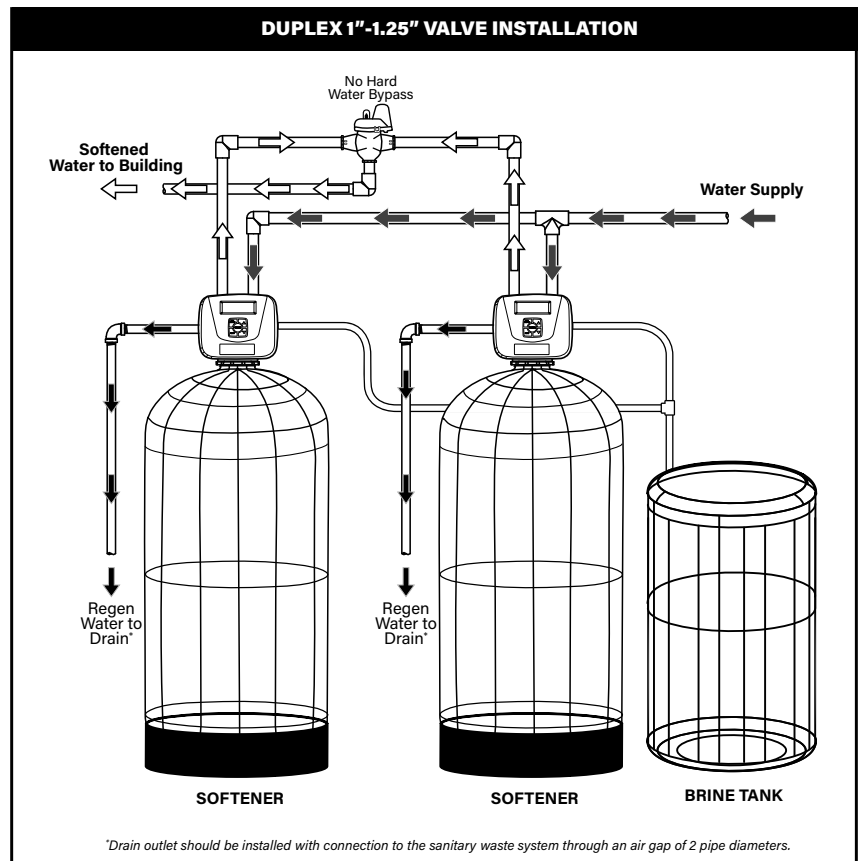
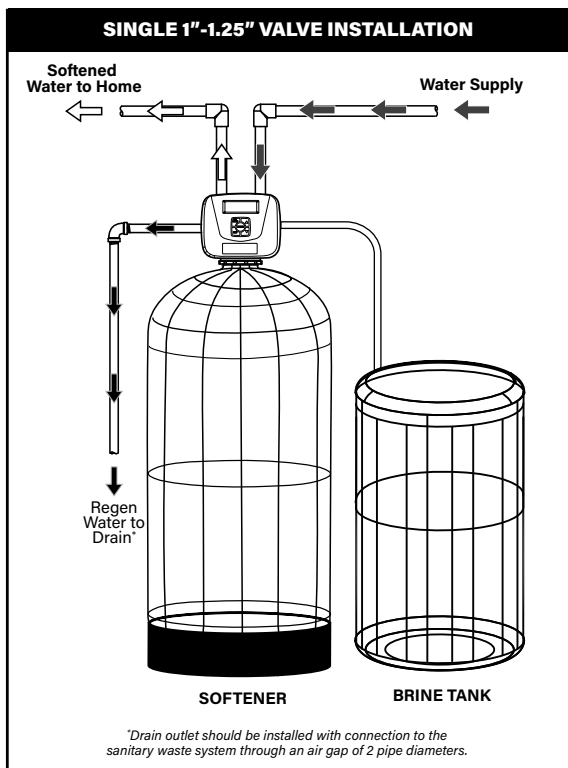

Transformer Details:	- Consumption: 9.5 Watts
- Supply Voltage: 110 Volt AC	- Output Voltage: 15 Volt DC
- Supply Frequency: 60 Hz Power	- Output Current: 500 mA

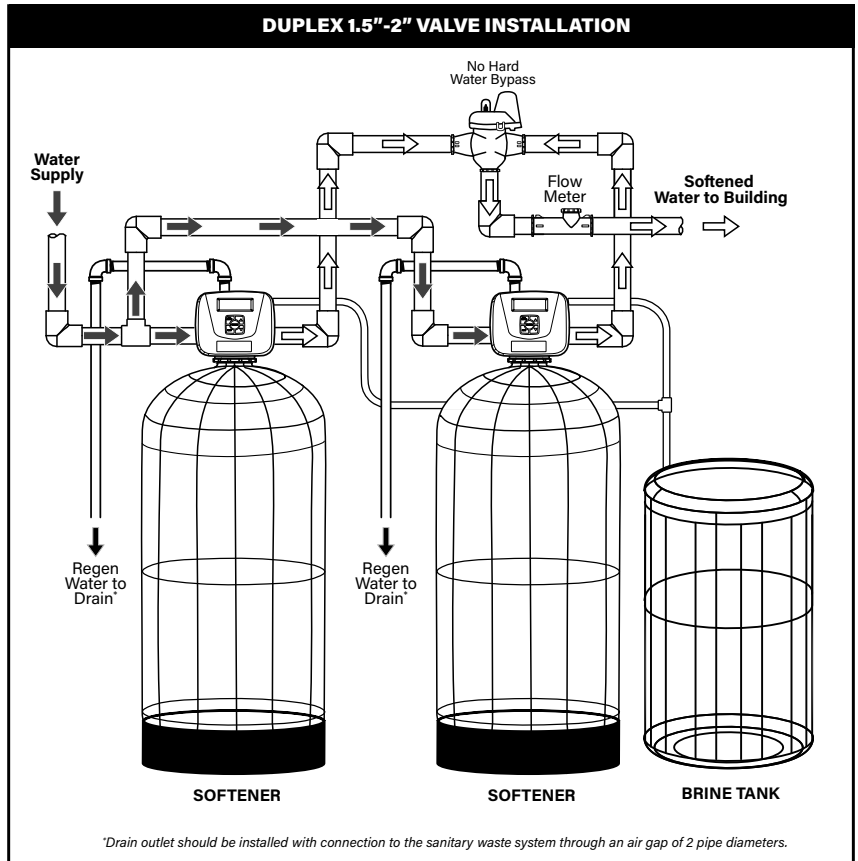
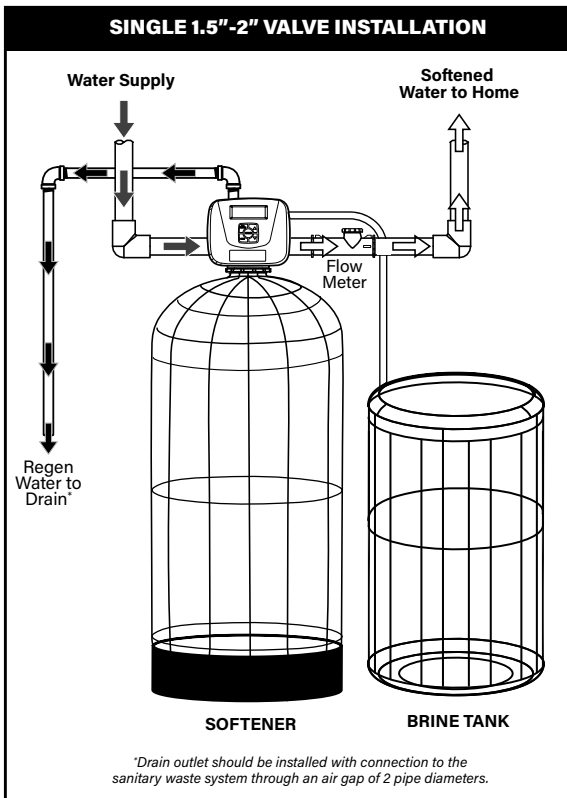

Transformer Details:	- Consumption: 9.5 Watts
- Supply Voltage: 110 Volt AC	- Output Voltage: 15 Volt DC
- Supply Frequency: 60 Hz Power	- Output Current: 500 mA

Post-INSTALLATION CHECKLIST

 **IMPORTANT—**
Do not plug the transformer into an outlet until instructed in the steps below.

- 1. Flush System—** After installation is complete, rotate the bypass valve handles to the bypass position shown in **Fig. 2** on page 4. With water pressure turned on, open a cold water faucet and allow water to clear pipes of debris which may occur during installation. Close cold water faucet.
- 2. Fill Brine Tank—** Manually pour water into brine tank until approximately 2" of water is visible in the tank. Then, add 160-200 lbs. of solar salt to the tank. Always keep salt above the water level in tank.
- 3. Set Time of Day—** Plug power cord into a 120/60 uninterrupted outlet. Press and hold **SET CLOCK** button until hour number is flashing. Use the Δ and ∇ buttons to set correct hour of day (cycle past 12 to change AM/PM). Press the **NEXT** button to advance to the minutes value and use the Δ or ∇ button to set current minute of the hour. Press **NEXT** to exit and save the current time. See page 3.
- 4. Start Up Instructions—**
 - Press and hold **REGEN** button until motor starts. When motor stops, valve will be in **BACKWASH** cycle of regeneration process.
 - **Unplug** power cord from 120/60 outlet. Rotate inlet side of bypass partially open so water enters system slowly, as shown in **Fig. 3** on page 4. Continue to until water is flowing from drain pipe at a steady pace and without any air; this indicated that the media tank is completely full.
 - **Rotate** the inlet side of the bypass to fully open position as shown in **Fig. 4** on page 4.

- **Plug** the power cord back into a 120/60 outlet. Press **REGEN** button to force motor to advance to **BRINE** position. While system is counting down, press **REGEN** again to advance motor to the **2ND BACKWASH** cycle. While system is counting down, press **REGEN** button a third time to advance the system to the **RINSE** cycle. While system is counting down, press **REGEN** button to advance the system to the **FILL** cycle. While system is counting down, press **REGEN** button a final time to advance motor to **SOFTENING** position. The time of day will return to the screen.

5. Release Treated Water— Slowly turn the outlet side of the bypass valve top open it as shown in **Fig. 1** on page 4. Unit is now providing conditioned water to the building.

VALVE SETTINGS— INSTALLER

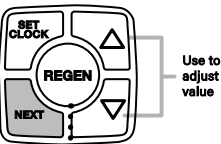
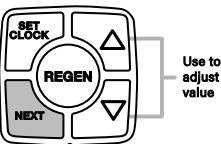
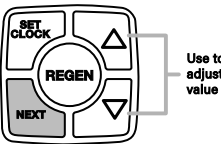
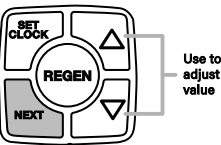
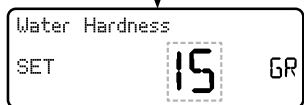
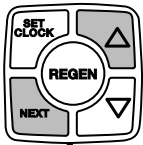
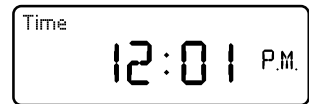

.....➔ Return to regular operating display screens

1. Access Programming— Press and hold **NEXT** and the Δ button simultaneously for 3 seconds.

2. Water Hardness— Use the Δ and ∇ buttons to set the grains of hardness as CaCO_3 per gallon. The grains per gallon can be increased if soluble iron needs to be reduced.

- **Range:** 1-150 grains
- This display will only appear if **Volume Capacity** is set to **AUTO** in advanced programming (see Advanced Water Technician's Guide).

3. Day Override— If **Volume Capacity** is set to **OFF**, this setting will control the number of days between regenerations. If **Volume Capacity** is set to **AUTO** or a specific number, this will set the **maximum** number of days between regenerations.

Use the Δ or ∇ button to select one of the following options:

- **Days Value:** Set a number (1-28) of days to trigger a regeneration, even if sufficient volume of water has not been used.
- **OFF:** System will only trigger a regeneration based on volume used.

4. Regeneration Time— Use the Δ or ∇ button to set the hour of the day regeneration should begin. The AM/PM designation will change as you scroll past 12. Press **NEXT** to change the minutes value.

- The ideal time will vary based on the owner's water usage habits. Set a regeneration time when treated water is not necessary.
- This display will not appear if **Regeneration Time Option** is set to **IMMEDIATE REGENERATION**.

5. Energy Saver— Use the Δ or ∇ button to select one of the following options:

- **ON:** The control will automatically turn off the display screen light after 5 minutes of keypad inactivity.
- **OFF:** The display screen light will always be illuminated.

Press **NEXT** to exit Installer Display Settings. — or — Press **REGEN** to return to previous step.

OPERATION & MAINTENANCE

REGENERATION MODE

A system is usually set to regenerate at a time of low water usage (*i.e. when a household is asleep or a business is using a minimal amount of water*). If there is a demand for water when the system is regenerating, untreated water will be used in single tank configurations.

When the system starts regeneration, the screen information will display the current cycle that is in process and the time remaining for that step to be completed. The system performs each cycle automatically and will return to the operating mode once all regeneration cycles are complete.

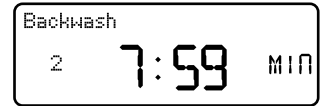

In multi-system installations, one unit will regenerate at any given time. A unit that needs to regenerate but is waiting another unit to finish, it will display STANDBY on the screen.

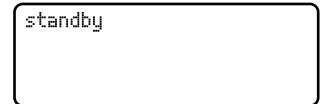

MANUAL REGENERATION

Occasionally, you may need to manually regenerate the system before the programming calls for it, such as after increased water usage or if the system has been operating without salt.

To start a manual regeneration, press and release the **REGEN** button. **REGEN TODAY** will flash on the display to indicate that the system will regenerate at the preset delayed regeneration time (*default is 2:00 AM*).

- Press **REGEN** again to cancel the request.

NOTE: If the **Regeneration Time Option** is set to **IMMEDIATE REGENERATION**, there is no delayed regeneration time designated in the programming. Therefore **REGEN TODAY** will not activate if **REGEN** is pressed. To initiate a manual regeneration immediately, press and hold **REGEN** for **3 seconds**. The system will begin to regenerate immediately. The request cannot be canceled.

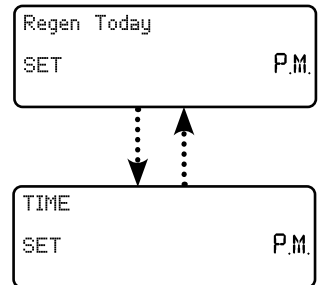

(For softeners, if brine tank does not contain salt, fill with salt and wait at least 2 hours before regenerating.)

POWER LOSS AND BATTERY REPLACEMENT

If an extended power outage occurs, the control valve will retain the time of day settings until the board's battery is depleted. If the battery is depleted, the screen will appear dark without any information. When this happens, it may be difficult to diagnose whether or not an issue was caused by a board failure or low battery. Follow the steps below to troubleshoot the issue:

1. Remove the valve cover and disconnect the power from the PC board via the 4-pin connector.
2. Pull the battery up to release it from the board housing. Wait 5 minutes for board to fully de-energize.
3. With the battery out, reconnect the power supply to the board. The screen should begin to show display information.
 - **This indicates that the board is operating correctly.**
 - **If the display does not work, call your local professional for service.**
4. **IMPORTANT:** unplug the transformer from the outlet before replacing with a new battery to avoid causing a short circuit that could damage the PC board. Install a 3 volt lithium coin cell type 2032 battery by pushing down into the housing on the board. Ensure the battery is fully seated into the bracket.
5. Reset the time of day (see Page 3) and initiate a regeneration (see Page 8).

Replace battery with 3 volt lithium coin cell type 2032.

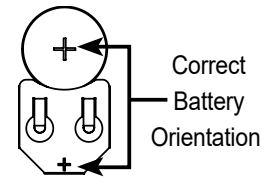

When replacing the battery, align positives and push down to fully seat.

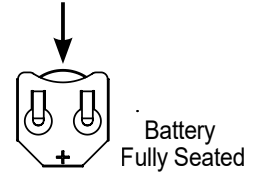

BRINE TANK MAINTENANCE AND SALT

Refill the brine tank as necessary, make sure it stays at least 1/3 full of salt at all times. Without proper salt levels, the water softener may not operate properly.

The brine tank will not hold water during its normal operation (a.k.a. dry salt storage). The brine tank is designed for the use of solar salts, pellets, or rock salt. **DO NOT USE BLOCK SALT** unless the dry salt storage feature is not being utilized. If pellet or rock salt is used, the manufacturer recommends cleaning the brine tank every 6 months.

ERROR MESSAGE

If the word **ERROR** appears and flashes alternately with the dealer name, take note of the error number displayed. This indicates a specific type of issue the control valve has experienced. Contact your dealer and share the error number to start the troubleshooting process.

See the following pages for a listing of the most common error codes and troubleshooting indicators.



ERROR CODES AND DESCRIPTIONS

Error Code Number	Definition	Description
101	Unable to start	Valve does not sense any movement with motor engaged
102	Motor stalled	Valve is not able to find the next cycle position
103	Motor ran too long	Valve is not able to find the next cycle position
104	Valve homing	Valve is not able to find the "Home" position
106	MAV 1 ran too long	MAV 1 was not able to find proper park position
107	MAV 1 stalled	MAV 1 motor ran too short and was not able to find proper park position
109	Invalid motor state	Control detected incorrect motor state and can no longer operate properly
116	MAV 2 ran too long	MAV 2 was not able to find proper park position
117	MAV 2 stalled	MAV 2 motor ran too short and was not able to find proper park position
201	Invalid regen step	Internal software issue regarding regeneration cycle steps causing controller to malfunction
204	Leak detected	Occurs when dP input is active for "ALARM" and the input is closed.
402	Power down memory	Check sum error for operational data and status section of EEPROM memory—specific type of memory error.
403	Program memory	Check sum error for operational data and status section of EEPROM memory—specific type of memory error.
404	Diagnostic memory	Check sum error for operational data and status section of EEPROM memory—specific type of memory error.
405	History memory	Check sum error for operational data and status section of EEPROM memory—specific type of memory error.
406	Contact memory	Check sum error for operational data and status section of EEPROM memory—specific type of memory error.
407	Status RAM memory failure	Control can no longer operate properly due to corrupted data detected in the Operational Data and Status Section of RAM memory. Once generated, the Error Mode is not entered nor an error displayed, instead previously stored data (<6 hours old) is used to maintain control operation.
408	Diagnostic RAM memory failure	Control can no longer operate properly due to corrupted data detected in the Operational Data and Status Section of RAM memory. Once generated, the Error Mode is not entered nor an error displayed, instead previously stored data (<6 hours old) is used to maintain control operation.
410	Config download	Configuration file downloaded to the control was not originally uploaded from another control with the identical software revision.

Press and hold **NEXT** and **REGEN** simultaneously for 3 seconds to perform a soft reset and clear an error.

IN-FIELD RESOLUTION GUIDE

Service Issue	Recommended Solution
Display is flashing Time of Day	Likely caused by a power outage. Reset Time of Day by following instructions in product's Installer & Owner's Manual. If system included a battery back up, replace it following instructions on Page 3.
Display is showing the wrong Time of Day	Unit has irregular access to power. Check to make sure product is not plugged into an outlet controlled by a light switch or a breaker/GFI was triggered. If no issues found with power source, replace the PC board.
There is nothing shown on display	The unit may have no access to power. Ensure adapter is plugged into an active outlet and cord is fully connected to PC board. If no issues found with power source, you have the option to replace the power adapter and/or the PC board.
Display does not show Flow Indicator icon while processing water	A flow meter may not be installed. Other possibilities include the unit being in Bypass position, the flow meter is not properly connected to the PC board, or something is lodged inside prohibiting turning of the blades. If no issues are found with the flow meter, it may be defective and should be replaced.
Unit is regenerating at wrong time of day	Ensure the Time of Day is correct and reset as needed by following instructions in product's Installer & Owner's Manual. Check the Time of Regeneration is set correctly and/or that programming setting has DELAYED regeneration selected. <i>(Immediate Regeneration will activate at random times.)</i>
Unit is not regenerating automatically when holding down the REGEN button	The valve cover may not be positioned correctly. Remove and reattach in proper position. Other reasons include a broken piston rod, broken drive gear, or broken drive cap assembly. If all components appear intact, replace the PC board.
Unit is not regenerating according to the system programming, but <i>will</i> while holding down the REGEN button	The unit may be in the Bypass position or the regeneration settings are not programmed correctly. Other possibilities include the flow meter is not connected to the PC board or something is lodged inside prohibiting turning of the blades. If no issues are found in the items above, you have the option to replace the flow meter and/or the PC board.
Water is running to the drain	Please review all of the following scenarios: <ul style="list-style-type: none"> ▪ After a power outage, the system will resume an interrupted regeneration process. If system included a battery back up, replace it following instructions on Page 3. ▪ Seal, stack assembly, or piston assembly may be damaged and needs to be replaced. ▪ Ensure drive cap assembly is tightened properly.

Additional common troubleshooting recommendations continue on next page

IN-FIELD RESOLUTION GUIDE

Service Issue	Recommended Solution
System is using too much regenerant	<p>Check the valve programming for REFILL setting, water quality setting, and regen frequency to ensure it matches the job site needs.</p> <p>Also ensure there are no leaking fixtures drawing water causing the unit to regenerate more often.</p>
Regenerant is present in treated water	<p>This could be caused by low water pressure entering the system. Ensure there is a minimum of 25 psi at all times. Also check for an incompatible, damaged, or plugged injector, and that the drain line is free from debris.</p>
Unfiltered or hard water is present after passing through the unit	<p>Please review all of the following scenarios:</p> <ul style="list-style-type: none"> ▪ Ensure the bypass is in the closed position. ▪ Check flow meter to ensure nothing is lodged inside. ▪ Media could be exhausted from unusually high water usage or changes in water quality. Test the water and adjust program settings as needed. ▪ Regenerant is available during regen cycles. Ensure brine tank has salt and system is able to draw in regenerant. <i>(See Service Issue below for details.)</i> ▪ Check seals, piston, and stack assembly for damage. ▪ Ensure the control valve type and piston type are compatible. ▪ The media may be fouled and needs to be replaced.
Unit does not draw in regenerant	<p>Please review all of the following scenarios:</p> <ul style="list-style-type: none"> ▪ Injector is plugged. Remove and replace part. ▪ The regenerant piston may be broken. Remove and replace part. ▪ Check the regenerant line for air leaks. ▪ Check the drain line for material restricting flow and causing excess back pressure. ▪ Drain line is too long or too high for proper drainage. ▪ Check incoming water pressure to ensure it maintains a minimum of 25 psi.
There is excessive water in the brine tank	<p>Please review all of the following scenarios:</p> <ul style="list-style-type: none"> ▪ Brine line is not fully inserted into connector elbow inside brine tank. ▪ Injector is plugged. Remove and replace part. ▪ The seal, stack assembly, or piston may be damaged. ▪ Check the REFILL setting in programming. ▪ Ensure drive cap assembly is tightened properly. ▪ Check the drain line for restrictions from debris or kinks in the line. ▪ Backwash flow controller is plugged. Remove and replace part. ▪ Refill flow controller is missing; replace part.

REPLACEMENT PARTS

Front Cover & Drive Assembly			
Drawing #	Part Number	Description	Quantity
1	V4576-01	VARSITY FRONT COVER ASSEMBLY BLACK	1
2	V3107-01	MOTOR ASSEMBLY	1
3	V3002	DRIVE BRACKET ASY W/ MOTOR	1
4	V4630CP-BOARD	WS1 THRU 2 CP PCB REPL	1
5	V3110	DRIVE REDUCING GEAR 12X36	3
6	V3109	DRIVE GEAR COVER	1
Not Shown	V3186-06	POWER SUPPLY US 15VDC HOCV	1
	V3186AUS-05OD	POWER SUPPLY AUS 15VDC VI OUTDOOR	
	V3186EU-06	POWER SUPPLY EU 15VDC HOCV	
	V3186UK-06	POWER SUPPLY UK 15VDC HOCV	
	V3186-01	POWER CORD ONLY	
Not Shown	V3946	BACKPLATE MIDSIZE	1

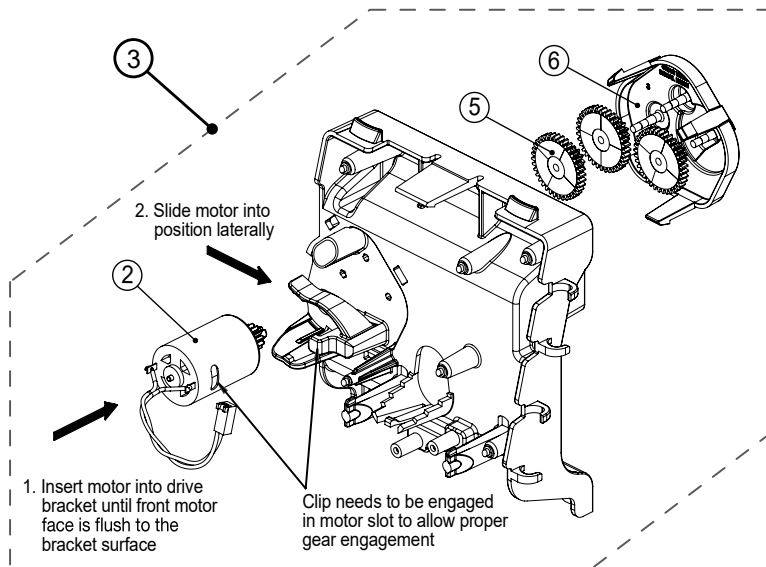
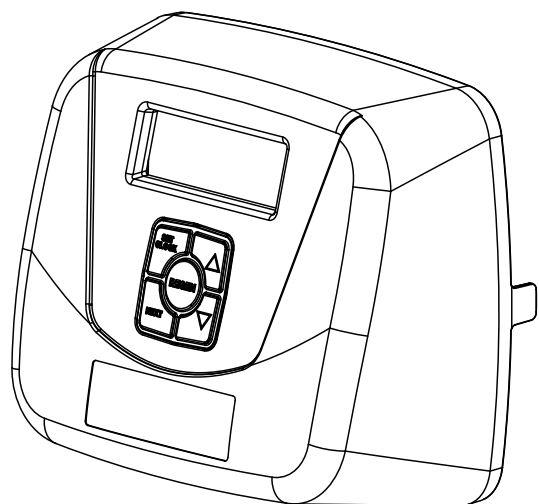

Battery replacement is 3 volt lithium coin cell type 2032.

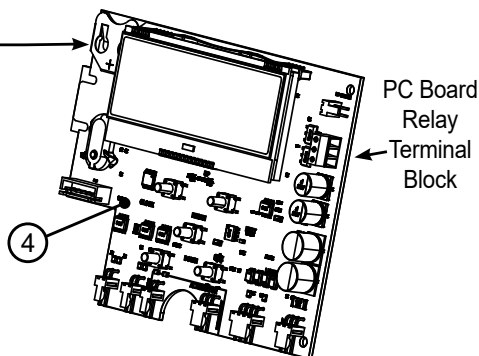
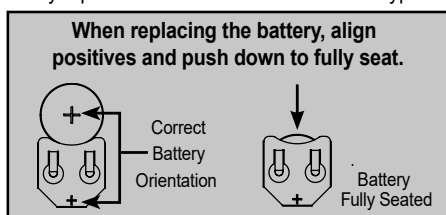

1"-1.25" DRIVE CAP ASSEMBLY, PISTONS, & STACK ASSEMBLY

DRAWING #	PART #	DESCRIPTION	QTY
1	V3005	WS1 Spacer Stack Assembly	1
2	V3004	Drive Cap Assembly	1
3	V3178	WS1 Drive Back Plate	1
4a	V3011*	WS1 Piston Downflow Assembly	1
4b	V3011-01*	WS1 Piston Upflow Assembly	1
5	V3174	WS1 Regenerant Piston	1
6	V3135	O-Ring 228	1
7	V3180	O-Ring 337	1
8	V3105	O-Ring 215 (Distributor Tube)	1
9	V3001-04	1" Body Assembly Downflow	1
	V3020	1.25" Body Assembly Downflow	1

*V3011 is labeled with DN and V3011-01 is labeled with UP
 NOTE: The regenerant piston is not used in backwash only applications.

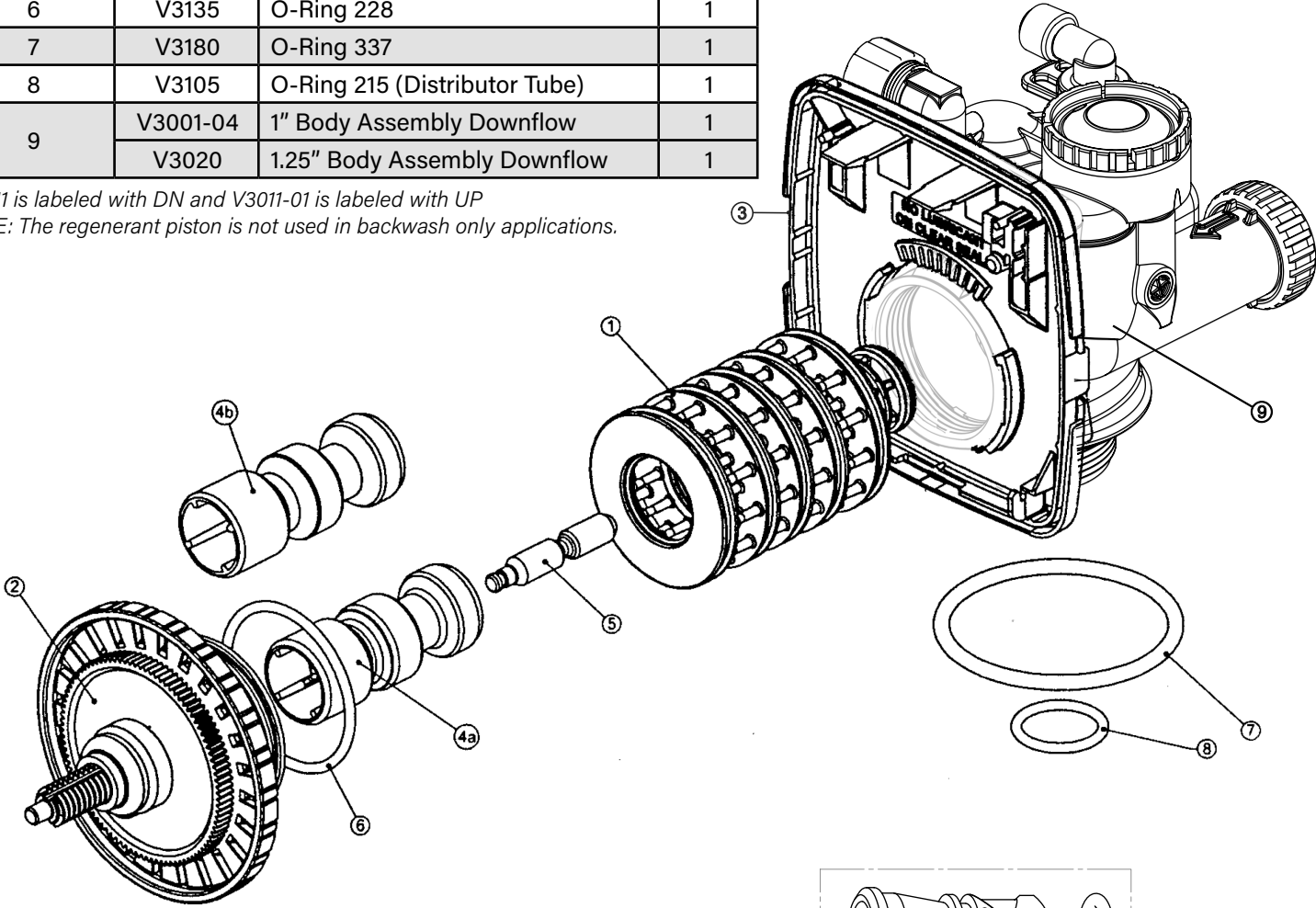

WATER METER & METER PLUG

DRAWING #	PART #	DESCRIPTION	QTY
1	V3151	WS1 Nut 1" QC	1
2	V3003*	WS1 Meter Assembly	1
3	V3118-01	WS1 Turbine Assembly	1
4	V3105	O-Ring 215	1
5	V3003-01	WS1 Meter Plug Assembly	1

*Order number V3003 includes V3118-01 and V3105

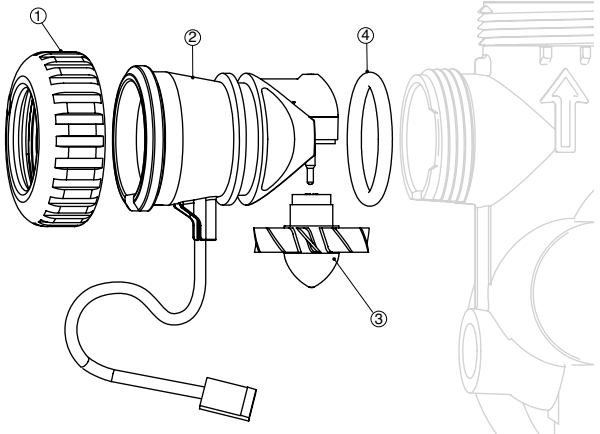

1.5" DRIVE CAP ASSEMBLY, PISTONS, & STACK ASSEMBLY			
DRAWING #	PART #	DESCRIPTION	QTY
1	V3004	Drive Cap Assembly	1
2	V3135	O-Ring 228	1
3	V3407	1.25" and 1.5" downflow piston assembly	1
4	V3174	WS1 Regenerant Piston	1
5	V3423	1.5 Backplate Dowel	1
6	V3430-01	1.25" and 1.5" Spacer Stack Assembly	1
7	V3178	WS1 Drive Backplate	1
8	V3419	O-Ring 347	1
9	V3641	O-Ring 328	1
10	V3400-01	1.5 Valve Body Downflow	1

NOTE: The regenerant piston is not used in backwash only applications.

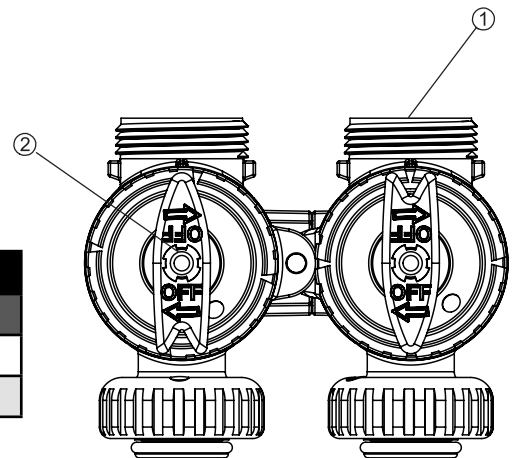
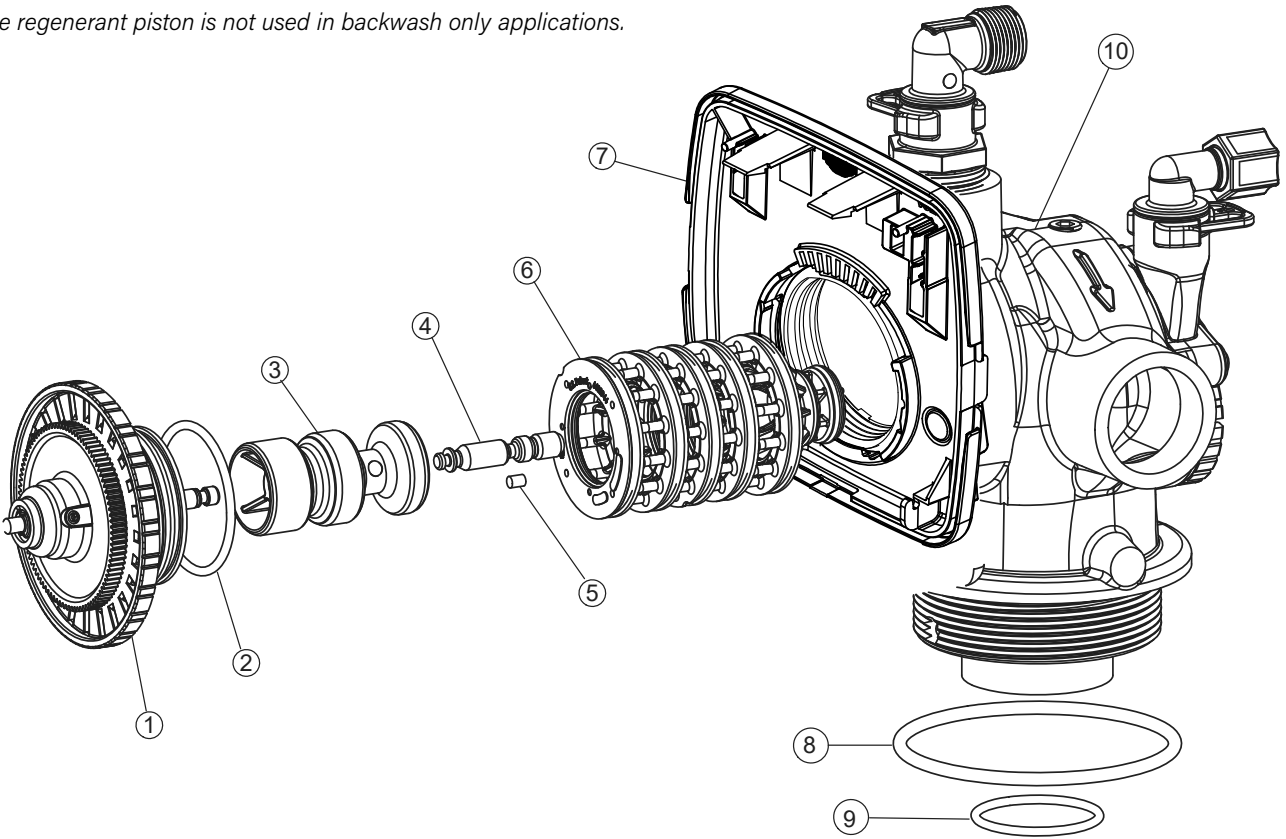

BYPASS: 1"-1.25" VALVES			
DRAWING #	PART #	DESCRIPTION	QTY
1	V3005	WS1 Spacer Stack Assembly	1
2	V3004	Drive Cap Assembly	1

2" DRIVE CAP ASSEMBLY, PISTONS, & STACK ASSEMBLY

DRAWING #	PART #	DESCRIPTION	QTY
1	V3726	WS2 Brine Piston Assembly	1
2	V3725	WS2 Piston Downflow Assembly	1
3	V3452	O-Right 230 (Tank Flange O-Ring)	1
4	V3728	WS2 Drive Cap Assembly	1
5	V3724	Washer, Flat SS 1/4	1
6	V3642	Bolt, BHCS S/S 1/4 20x1.25	1
7	V3178	Drive Backplate	1
8	V3729	WS2 Stack Assembly	1
9	V3419	O-Ring 347 for WS15	1
10	V3541	O-Ring 225 (for bodies with NPT threads)	1
11	V3700-01	WS2 Body, NPT	1
Not Shown	V3468	WS2H Plug, 1/4 Hex NPT	1
	D1300-01	Top Baffle DFSSR Clack 1.5/50mm	1

NOTE: The regenerant piston is not used in backwash only applications.

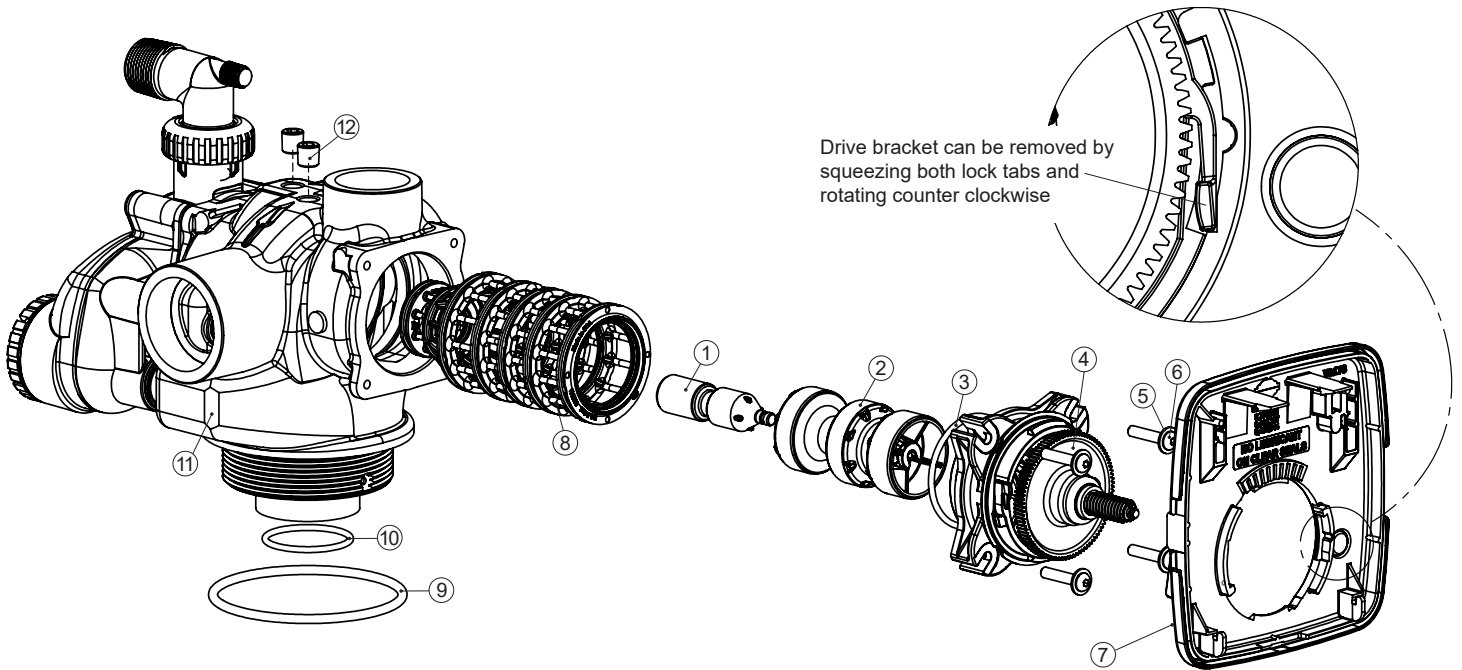

REFILL FLOW CONTROL & PORT PLUG			
DRAWING #	PART #	DESCRIPTION	QTY
1	V3195-01	WS1 Refill Port Plug Assembly*	1
2	H4615	Elbow Locking Clip	1
3	JCP-P-6	Polytube Insert 3/8	1
4	JCPG-6PBLK	Nut 3/8	1
5	H4613	Elbow Cap 3/8	1
6	V3163	O-Ring 019	1
7	V3165-01**	WS1 RFC Retainer Assembly	1
8	V3182	WS1 RFC	1
Not Shown	H4650	Elbow 1/2" with Nut and Insert	Option

*This part is required for backwash only systems

**Assembly includes WS1 RFC

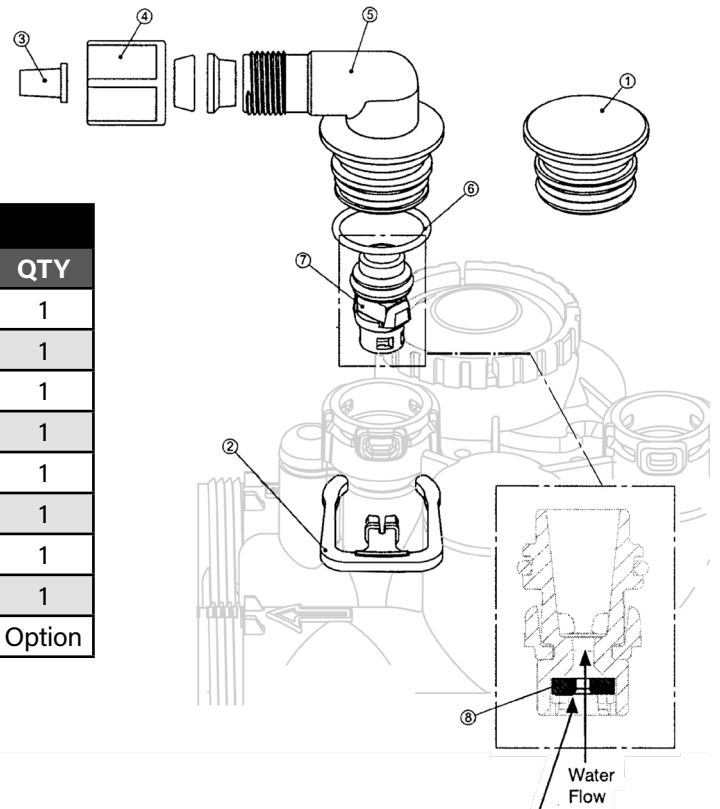

Proper RFC orientation directs refill water flow towards the washer face with rounded edge and text.

1" VALVE INJECTOR PARTS			
DRAWING #	PART #	DESCRIPTION	QTY
1	V3176	Injector Cap	1
2	V3152	O-Ring 135	1
3	V3177	Injector Screen	1
4	V3010-1Z	WS1 Injector Assembly Z Plug	1
5	V3010-1A	WS1 Injector Assembly A: Black	1
	V3010-1B	WS1 Injector Assembly B: Brown	
	V3010-1C	WS1 Injector Assembly C: Violet	
	V3010-1D	WS1 Injector Assembly D: Red	
	V3010-1E	WS1 Injector Assembly E: White	
	V3010-1F	WS1 Injector Assembly F: Blue	
	V3010-1G	WS1 Injector Assembly G: Yellow	
	V3010-1H	WS1 Injector Assembly H: Green	
	V3010-1I	WS1 Injector Assembly I: Orange	
	V3010-1J	WS1 Injector Assembly J: Light Blue	
V3010-1K	WS1 Injector Assembly K: Light Green		
Not Shown	V3170	O-Ring 011	*
Not Shown	V3171	O-Ring 013	*

*Injector plug and injectors each contain one 011 (lower) and one 013 (upper) o-ring.

NOTE: For upflow position, injector is located in the up hole and injector plug in the down hole. For a filter that only backwashes, injector plugs are located in both holes.

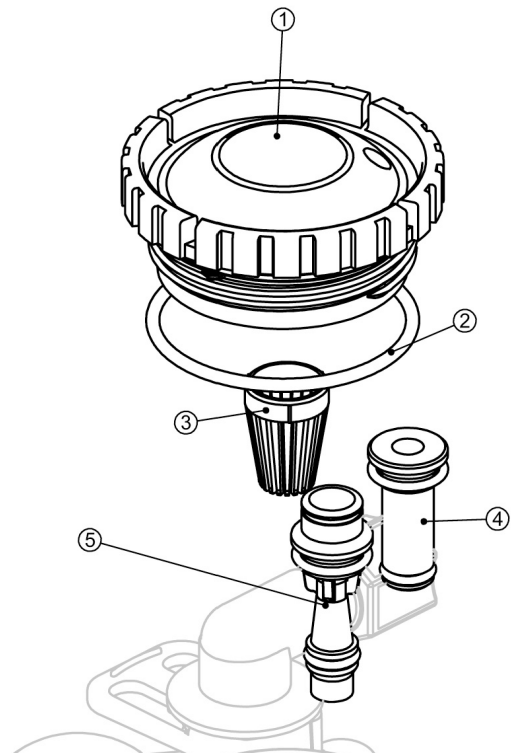

1.5" INJECTOR PARTS			
DRAWING #	PART #	DESCRIPTION	QTY
1	V3967	WS1.5 Injector Body, Welded Assembly	1
2	V3441	O-Ring 226	1
3	V3968	WS1.5 Injector Feed Tube Dnflw, BLK	1
	V3968-01	WS1.5 Injector Feed Tube Upflw, Gray	1
4	V3177-01	WS1 Injector Screen	1
5	V3969	WS1.5 Injector Draw Tube Dnflw, BLK	1
	V3969-01	WS1.5 Injector Draw Tub Upflw, Gray	1
6	V3176	WS1 Injector Cap	1
7	V3152	O-Ring 135	1
8	V3010-15B	WS1.5 Injector Assembly B	1
	V3010-15C	WS1.5 Injector Assembly C	1
	V3010-15D	WS1.5 Injector Assembly D	1
	V3010-15E	WS1.5 Injector Assembly E	1
	V3010-15F	WS1.5 Injector Assembly F	1
	V3010-15G	WS1.5 Injector Assembly G	1
	V3010-15H	WS1.5 Injector Assembly H	1
	V3010-15I	WS1.5 Injector Assembly I	1
V3010-15Z	WS1.5 Injector Assembly Z	1	
9	V3498	Refill Flow Control 1/2"	1
10	V3428	WS1.5 Refill Retainer Assembly (0.5 GPM)	1
11	V3163	O-Ring 019	1
12	H4612	Regenerant Elbow with Flow Control	1
13	JCPG-8PBLK	Nut, Compression 1/2" Black	1
14	JCP-P-8	Insert, Polytube 1/2"	1
15	V3182	Refill Flow Control (0.5 GPM)	1
16	H4615	Retaining Clip	1
17	V3724	Washer, Flat Stainless Steel	1
18	V3642	Bolt, BHCS Stainless Steel	1
19	V3195-01	Refill Port Plug	1

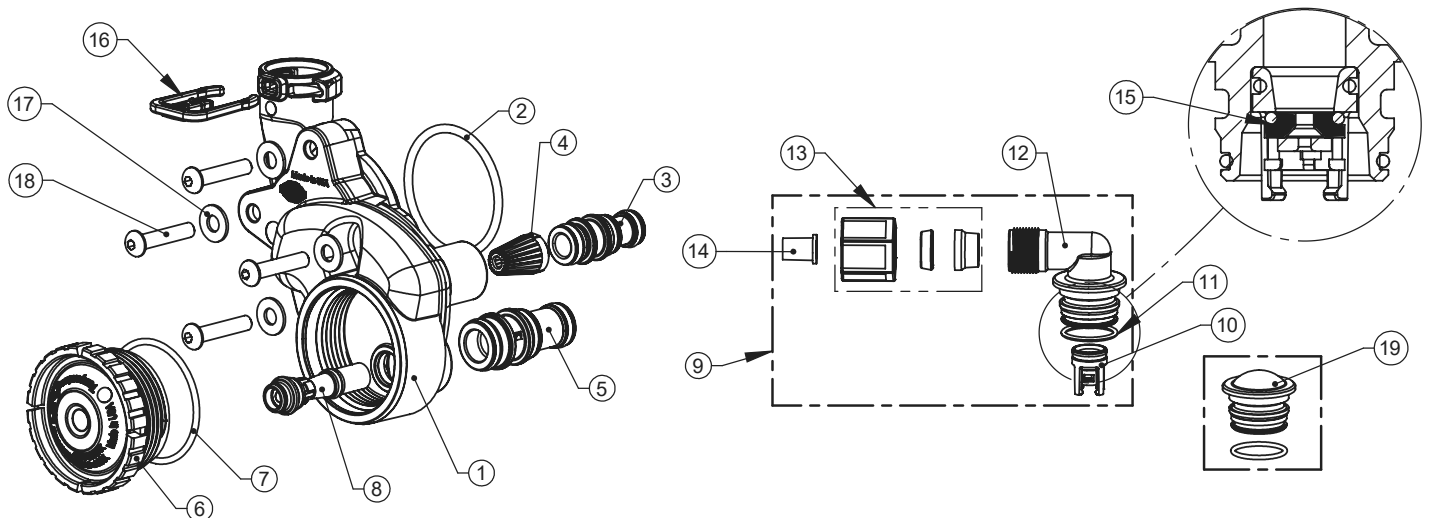

2" INJECTOR PARTS

DRAWING #	PART #	DESCRIPTION	QTY
1	V3477	WS2H Injector Cap	1
2	V3152	O-Ring 135	1
3	V3727	WS2 Injector Body Assembly	1
4	V3010-2R-15B	WS2/2H INJ R Assembly W/CV3010-15B	1
	V3010-2S-15C	WS2/2H INJ S Assembly W/CV3010-15C	1
	V3010-2T-15D	WS2/2H INJ T Assembly W/CV3010-15D	1
	V3010-2U-15E	WS2/2H INJ U Assembly W/CV3010-15E	1
	V3010-2V-15F	WS2/2H INJ V Assembly W/CV3010-15F	1
	V3010-2W-15G	WS2/2H INJ W Assembly W/CV3010-15G	1
	V3010-2X-15H	WS2/2H INJ X Assembly W/CV3010-15H	1
	V3010-2A	WS2/2H Injector Assembly A	1
	V3010-2B	WS2/2H Injector Assembly B	1
	V3010-2C	WS2/2H Injector Assembly C	1
	V3010-2D	WS2/2H Injector Assembly D	1
	V3010-2E	WS2/2H Injector Assembly E	1
	V3010-2F	WS2/2H Injector Assembly F	1
V3010-2G	WS2/2H Injector Assembly G	1	
5	V3731	WS2 Injector Draw Tube, Dwn Assembly	1
6	V3730	WS2 Injector Feed Tube, Dwn Assembly	1
7	V3315	O-Ring 231	1
8	V3724	Washer Flat SS 1/4	1
9	V3643	Bolt BHCS S/S 1/4-20 x 2.25	1
10	V3162-022	WS1 DLFC 022-3/4	1
11	V3231	WS2H Refill Flow Control Retainer	1
12	V3277	O-Ring 211	1
13	V3105	O-Ring 215	1
14	V3150	WS1 Split Ring	1
15	V3151	WS1 Nut 1 QC	1
16	V3149	WS1 FTG 1 PVC Male NPT Elbow	1

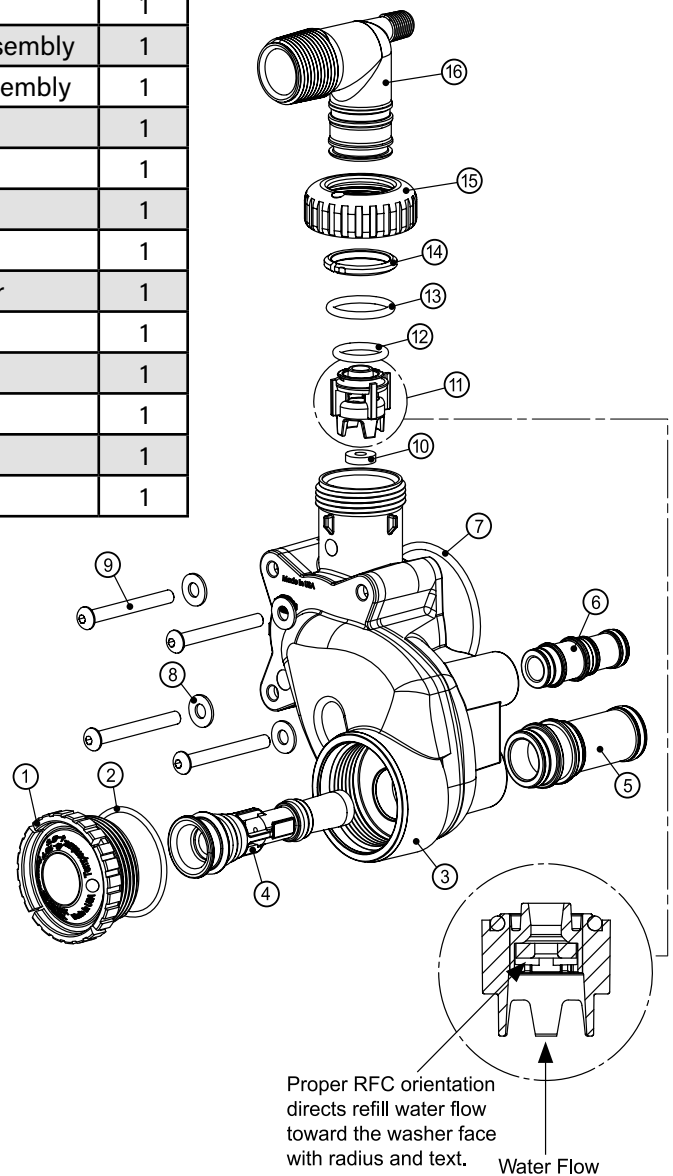

DRAIN LINE — 3/4"

DRAWING #	PART #	DESCRIPTION	QTY
1	H4615	Elbow Locking Clip	1
2	PKP10TS8-BULK	Polytube Insert 5/8	Option
3	V3192	WS1 Nut 3/4 Drain Elbow	Option
4	V3158-01	WS1 Drain Elbow 1/4 Male Assembly	1
5	V3163	O-Ring 019	1
6	V3159-01	WS1 DLFC Retainer Assembly	1
7	V3162-007	WS1 DLFC 0.7 gpm for 3/4	One DLFC must be used if 3/4" fitting is used
	V3162-010	WS1 DLFC 1.0 gpm for 3/4	
	V3162-013	WS1 DLFC 1.3 gpm for 3/4	
	V3162-017	WS1 DLFC 1.7 gpm for 3/4	
	V3162-022	WS1 DLFC 2.2 gpm for 3/4	
	V3162-027	WS1 DLFC 2.7 gpm for 3/4	
	V3162-032	WS1 DLFC 3.2 gpm for 3/4	
	V3162-042	WS1 DLFC 4.2 gpm for 3/4	
	V3162-053	WS1 DLFC 5.3 gpm for 3/4	
	V3162-065	WS1 DLFC 6.5 gpm for 3/4	
	V3162-075	WS1 DLFC 7.5 gpm for 3/4	
	V3162-090	WS1 DLFC 9.0 gpm for 3/4	
	V3162-100	WS1 DLFC 10.0 gpm for 3/4	

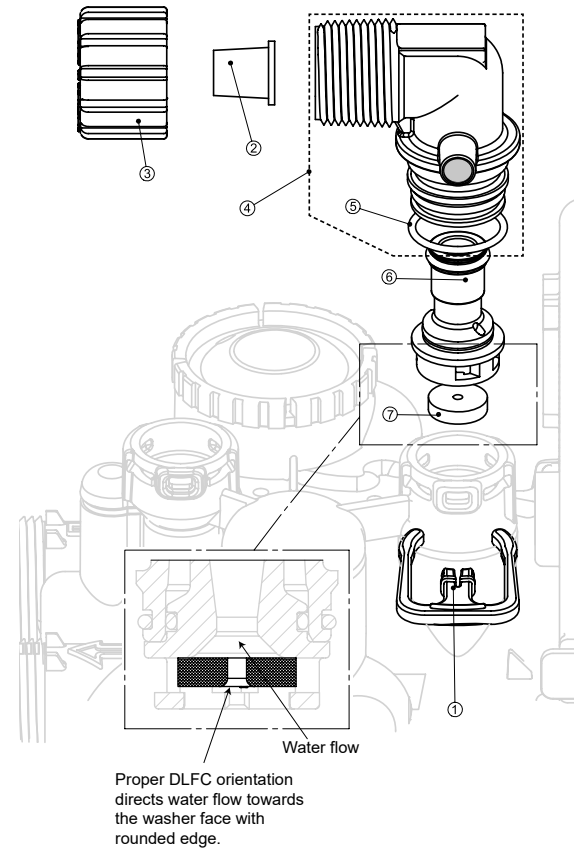

Valves are shipped without drain line flow control (DLFC) — install DLFC before using. Valves are shipped without 3/4" nut for drain elbow (polytube installation only) and 5/8" polytube insert (polytube installation only).

DRAIN LINE — 1"

DRAWING #	PART #	DESCRIPTION	QTY
1	H4615	Elbow Locking Clip	1
2	V3008-02	WS1 Drain FTG 1 Straight	1
3*	V3166	WS1 Drain FTG Body1	1
4*	V3167	WS1 Drain FTG Adapter	1
5*	V3163	O-Ring 019	1
6*	V3150	WS1 Split Ring	1
7*	V3151	WS1 Nut 1" QC	1
8*	V3105	O-Ring 215	1
9	V3190-090	WS1 DLFC 9.0 gpm for 1	One DLFC must be used if 1" fitting is used
	V3190-100	WS1 DLFC 10.0 gpm for 1	
	V3190-110	WS1 DLFC 11.0 gpm for 1	
	V3190-130	WS1 DLFC 13.0 gpm for 1	
	V3190-150	WS1 DLFC 15.0 gpm for 1	
	V3190-170	WS1 DLFC 17.0 gpm for 1	
	V3190-200	WS1 DLFC 20.0 gpm for 1	
	V3190-250	WS1 DLFC 25.0 gpm for 1	

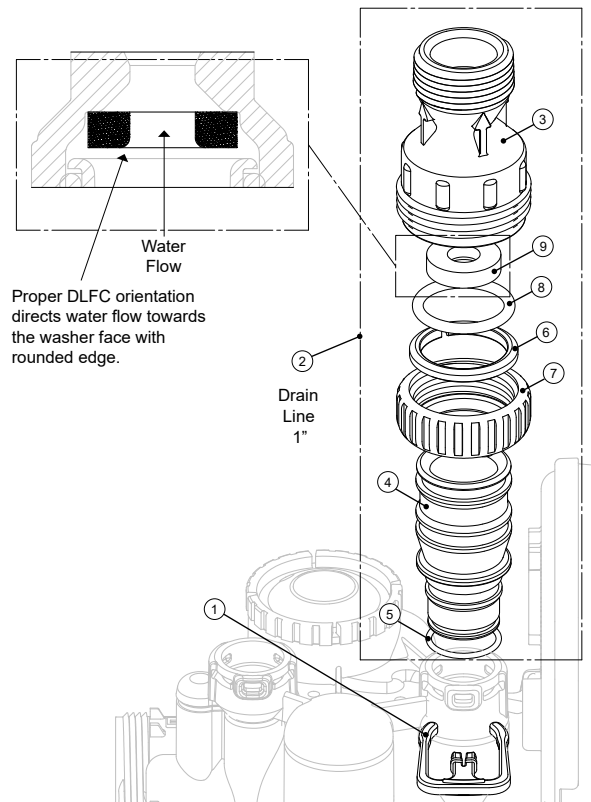

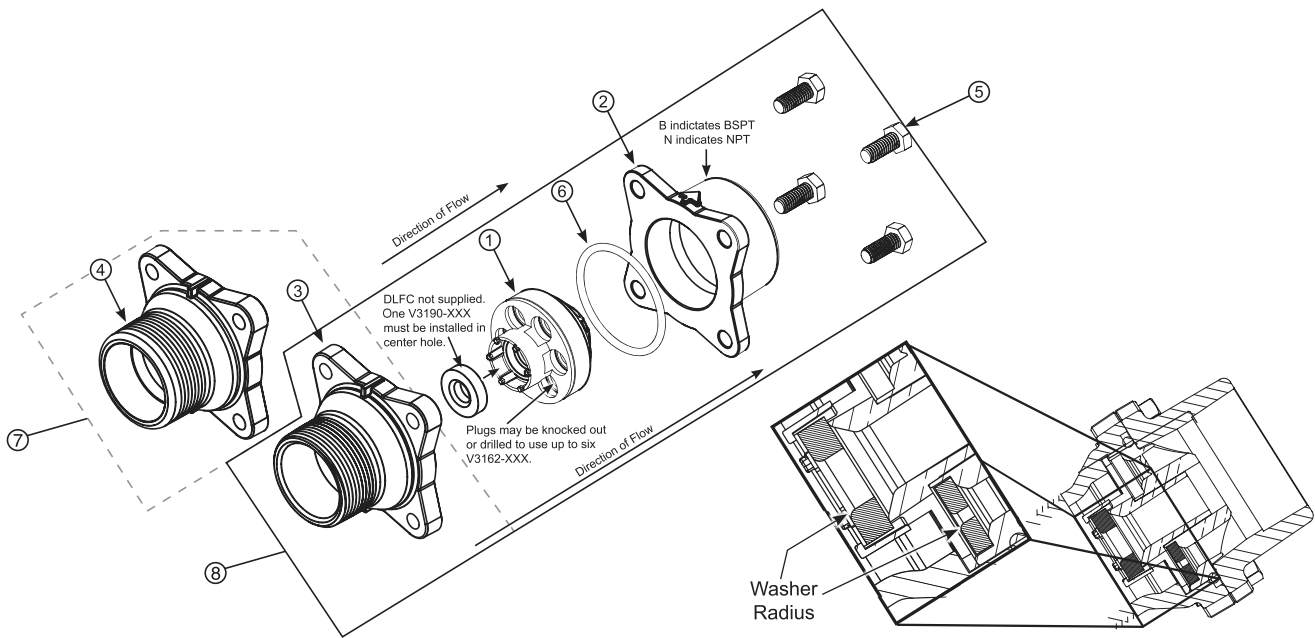

DRAIN LINE — 1.25" and 1.5"			
DRAWING #	PART #	DESCRIPTION	QTY
1	V3081	WS15 Retainer DLFC Assembly	1
2	V3645	WS15 DLFC Flange Outlet FNPT	1
3	V3646	WS15 DLFC Flange Inlet MNPT	1
4	V3647	WS125 DLFC Flange Inlet MNPT	1
5	V3652	Bolt, Hex HD, 5/16- 18 x 3/4	1
6	V3441	O-Ring 226	1
7	V3079	WS DLFC 1.25x1.5 Assembly	1
8	V3080	WS DLFC 1.5x1.5 Assembly	1
Not Shown (Install one V3190-XXX in center hole; knock out plugs. Allow installation of up to 6 more of V3162-XXX.)	V3162-007	WS1 DLFC 0.7 gpm for 3/4	1
	V3162-010	WS1 DLFC 1.0 gpm for 3/4	1
	V3162-013	WS1 DLFC 1.3 gpm for 3/4	1
	V3162-017	WS1 DLFC 1.7 gpm for 3/4	1
	V3162-022	WS1 DLFC 2.2 gpm for 3/4	1
	V3162-027	WS1 DLFC 2.7 gpm for 3/4	1
	V3162-032	WS1 DLFC 3.2 gpm for 3/4	1
	V3162-042	WS1 DLFC 4.2 gpm for 3/4	1
	V3162-053	WS1 DLFC 5.3 gpm for 3/4	1
	V3162-065	WS1 DLFC 6.5 gpm for 3/4	1
	V3162-075	WS1 DLFC 7.5 gpm for 3/4	1
	V3162-090	WS1 DLFC 9.0 gpm for 3/4	1
	V3162-100	WS1 DLFC 10.0 gpm for 3/4	1
	V3190-090	WS1 DLFC 9.0 gpm for 1	1
	V3190-100	WS1 DLFC 10.0 gpm for 1	1
	V3190-110	WS1 DLFC 11.0 gpm for 1	1
	V3190-130	WS1 DLFC 13.0 gpm for 1	1
	V3190-150	WS1 DLFC 15.0 gpm for 1	1
	V3190-170	WS1 DLFC 17.0 gpm for 1	1
	V3190-200	WS1 DLFC 20.0 gpm for 1	1
V3190-250	WS1 DLFC 25.0 gpm for 1	1	

DRAIN LINE — 2"			
DRAWING #	PART #	DESCRIPTION	QTY
1	V3052	WS15 Retainer DLFC Assembly	1
2	V3245	WS15 DLFC Flange Outlet FNPT	1
3	V3646	WS15 DLFC Flange Inlet MNPT	1
4	V3273	WS125 DLFC Flange Inlet MNPT	1
5	V3441	O-Ring 338	1
Not Shown (Install one V3190-XXX in center hole; knock out plugs. Allow installation of up to 6 more of V3162-XXX.)	V3162-007	WS1 DLFC 0.7 gpm for 3/4	1
	V3162-010	WS1 DLFC 1.0 gpm for 3/4	1
	V3162-013	WS1 DLFC 1.3 gpm for 3/4	1
	V3162-017	WS1 DLFC 1.7 gpm for 3/4	1
	V3162-022	WS1 DLFC 2.2 gpm for 3/4	1
	V3162-027	WS1 DLFC 2.7 gpm for 3/4	1
	V3162-032	WS1 DLFC 3.2 gpm for 3/4	1
	V3162-042	WS1 DLFC 4.2 gpm for 3/4	1
	V3162-053	WS1 DLFC 5.3 gpm for 3/4	1
	V3162-065	WS1 DLFC 6.5 gpm for 3/4	1
	V3162-075	WS1 DLFC 7.5 gpm for 3/4	1
	V3162-090	WS1 DLFC 9.0 gpm for 3/4	1
	V3162-100	WS1 DLFC 10.0 gpm for 3/4	1
	V3190-090	WS1 DLFC 9.0 gpm for 1	1
	V3190-100	WS1 DLFC 10.0 gpm for 1	1
	V3190-110	WS1 DLFC 11.0 gpm for 1	1
	V3190-130	WS1 DLFC 13.0 gpm for 1	1
	V3190-150	WS1 DLFC 15.0 gpm for 1	1
	V3190-170	WS1 DLFC 17.0 gpm for 1	1
	V3190-200	WS1 DLFC 20.0 gpm for 1	1
V3190-250	WS1 DLFC 25.0 gpm for 1	1	
	V3051	WS2 DLFC NPT Assembly	

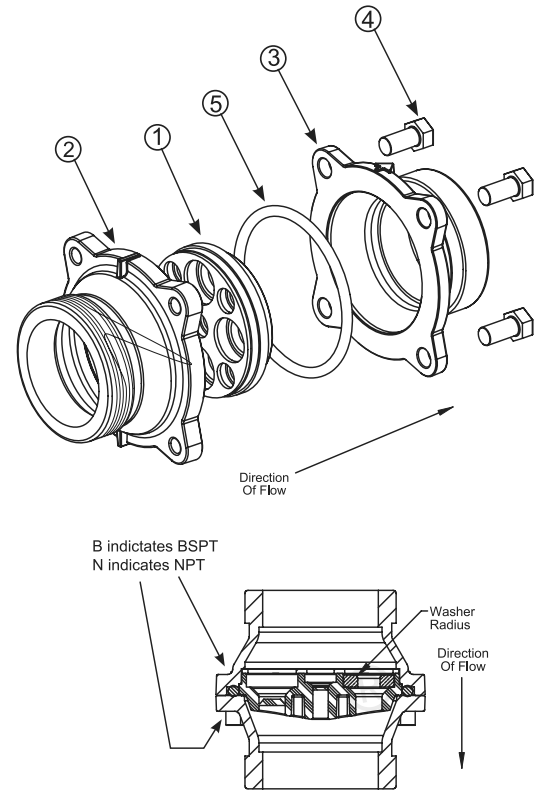

DRAIN LINE — 2"			
DRAWING #	PART #	DESCRIPTION	QTY
1	V3190-090	WS1 DLFC 9.0 gpm for 1	1
	V3190-100	WS1 DLFC 10.0 gpm for 1	1
	V3190-110	WS1 DLFC 11.0 gpm for 1	1
	V3190-130	WS1 DLFC 13.0 gpm for 1	1
	V3190-150	WS1 DLFC 15.0 gpm for 1	1
	V3190-170	WS1 DLFC 17.0 gpm for 1	1
	V3190-200	WS1 DLFC 20.0 gpm for 1	1
2	V3765-01	WS3 DLFC Housing NPT	1
3	V3766	WS3 DLFC Retainer	1
4	V3767	WS3 DLFC Retainer Cover	1
5	V3768	WS3 DLFC Retainer Ring	1
6	V3769	O-Ring 336	1
	V3764	WS3 DLFC NPT Assembly	1

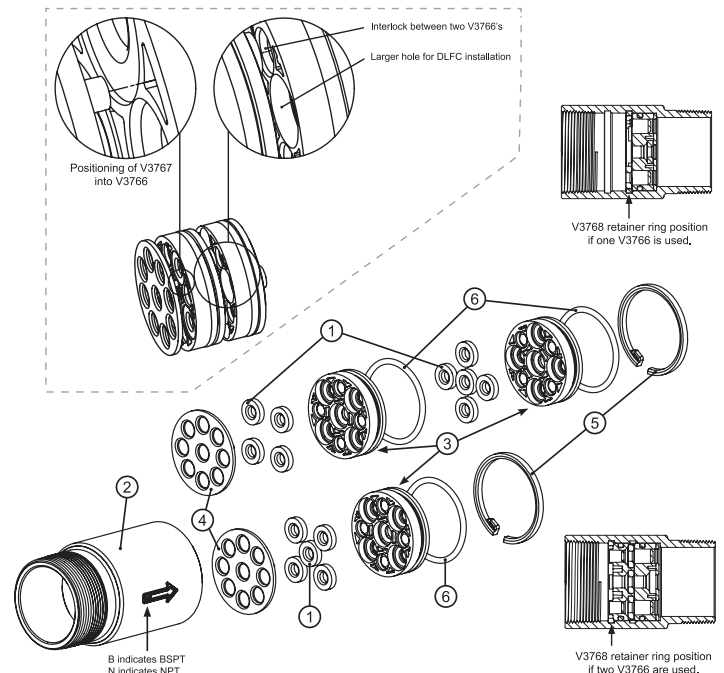

1" AND 1.25" NHWBP PARTS

DRAWING #	PART #	DESCRIPTION	QTY
1	V3073	MAV/NOWHBY Cover Assembly	1
2	V3476	WS Motor Assembly, 8ft	1
3	V3592	Screw, #8 3/4, PHPN T-25 SS	1
4	V3262-01	WS1.5 & 2 Alt/2By Reduction Gear Cover Assembly	1
5	V3110	WS1 Drive Reducing Gear 12x36	1
6	V3264	WS2 Bypass Reduct Gear Axle	1
7	V3527	Screw, 1/4-20 x 3/4, BHSCS SS	1
8	V3072	MAV/NOWHBY 1/1.25/1.5 Drive Assembly	1
9	V3506-01	MAV/NOHRD 1/1.25/1.5 Piston	1
10	V3074	MAC/NOHWBY 1/1.25/1.5 Stack Assembly	1
11	V3521FF	NOHRD Water Bypass Body Assembly F-F	1
12	V3521FM	NOHRD Water Bypass Body Assembly F-M	1
13	V3151	WS1 Nut, QC	1
14	V3150	WS1 Split Ring	1
15	V3105	O-Ring 215	1
	V3070FF	No Hard Water Bypass 1/1.25 F-F Assembly	1
	V3070FM	No Hard Water Bypass 1/1.25 F-M Assembly	1

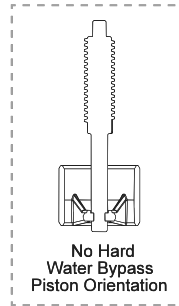
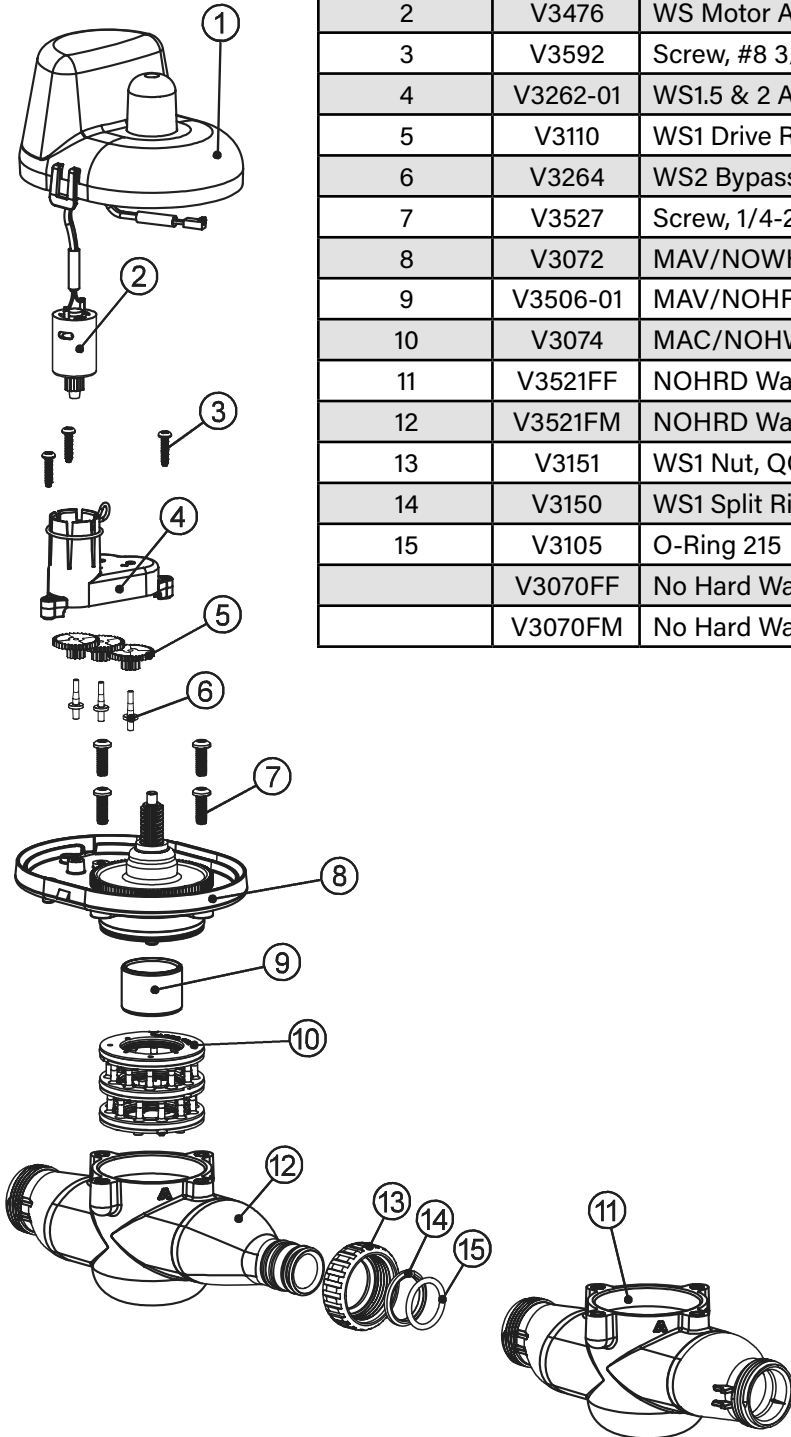

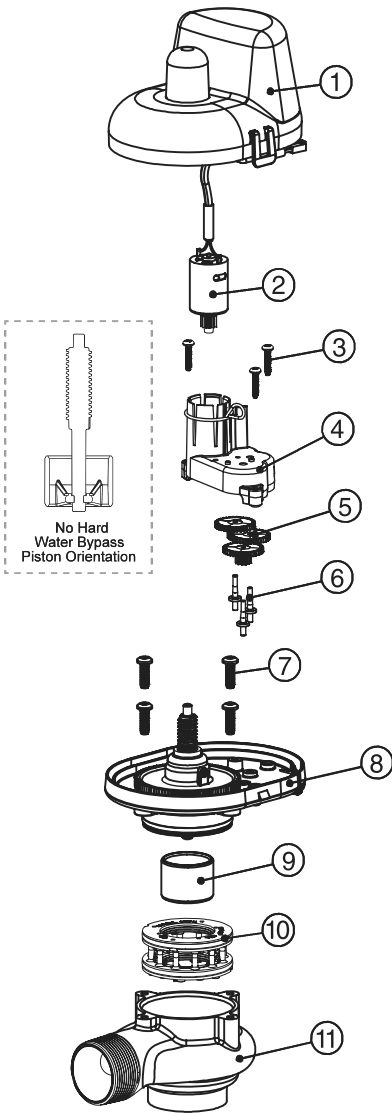

1.5" NHWP PARTS			
DRAWING #	PART #	DESCRIPTION	QTY
1	V3073	MAV/NOWHBY Cover Assembly	1
2	V3476	WS Motor Assembly, 8ft	1
3	V3592	Screw, #8 3/4, PHPN T-25 SS	1
4	V3262-01	WS1.5 & 2 Alt/2By Reduction Gear Cover Assembly	1
5	V3110	WS1 Drive Reducing Gear 12x36	1
6	V3264	WS2 Bypass Reduct Gear Axle	1
7	V3527	Screw, 1/4-20 x 3/4, BHSCS SS	1
8	V3072	MAV/NOWHBY 1/1.25/1.5 Drive Assembly	1
9	V3506-01	MAV/NOHRD 1/1.25/1.5 Piston	1
10	V3886	WS15 NHWBY Stack Assembly	1
11	V3832-01	WS15 NHWBY Body M x F NPT	1
Not Shown	V3805	Stain Relief Cover Kit	1
	V3097	No Hard Water Bypass 1.5 M x F NPT Assembly	1

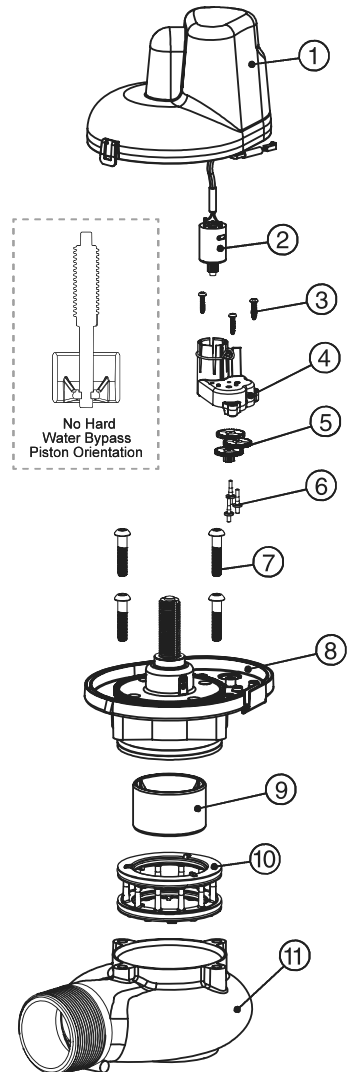

2" NHWP PARTS			
DRAWING #	PART #	DESCRIPTION	QTY
1	V3073	MAV/NOWHBY Cover Assembly	1
2	V3476	WS Motor Assembly, 8ft	1
3	V3592	Screw, #8 3/4, PHPN T-25 SS	1
4	V3262-01	WS1.5 & 2 Alt/2By Reduction Gear Cover Assembly	1
5	V3110	WS1 Drive Reducing Gear 12x36	1
6	V3264	WS2 Bypass Reduct Gear Axle	1
7	V3642	Screw 1/4-20 x 1-1/4, BHSCS SS	1
8	V3078	MAV/NOHWBY 2 Drive Assembly	1
9	V3634-01	MAV/NOHWBY 2 Piston	1
10	V3887	WS2 NHWBY Stack Assembly	1
11	V3832-01	WS15 NHWBY Body M x F NPT	1
Not Shown	V3805	Stain Relief Cover Kit	1
	V3098	Motor Alt Valve 2 NPT R EV2 Assembly	1

1" AND 1.25" MAV PARTS

DRAWING #	PART #	DESCRIPTION	QTY
1	V3073	MAV/NOWHBY Cover Assembly	1
2	V3476	WS Motor Assembly, 8ft	1
3	V3592	Screw, #8 3/4, PHPN T-25 SS	1
4	V3262-01	WS1.5 & 2 Alt/2By Reduction Gear Cover Assembly	1
5	V3110	WS1 Drive Reducing Gear 12x36	1
6	V3264	WS2 Bypass Reduct Gear Axle	1
7	V3527	Screw, 1/4-20 x 3/4, BHSCS SS	1
8	V3072	MAV/NOWHBY 1/1.25/1.5 Drive Assembly	1
9	V3506-01	MAV/NOHRD 1/1.25/1.5 Piston	1
10	V3074	MAV/NOHWBY 1/1.25/1.5 Piston	1
11	V3504FF	MAV Body 1/1.25 Assembly F-F	1
12	V3504MM	MAV Body 1/1.25 Assembly M-M	1
13	V3151	WS1 Nut, QC	1
14	V3150	WS1 Split Ring	1
15	V3105	O-Ring 215	1
Not Shown	V3474	WS Alt MAV 1/1.25 Cord, 8ft Black	1
	V3069FF	Motor Alt Valve 1/1.25 F-F Assembly	
	V3069MM	Motor Alt Valve 1 /1.25 M-M Assembly	

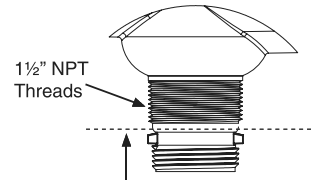
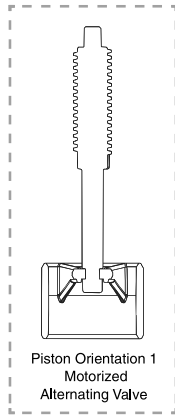
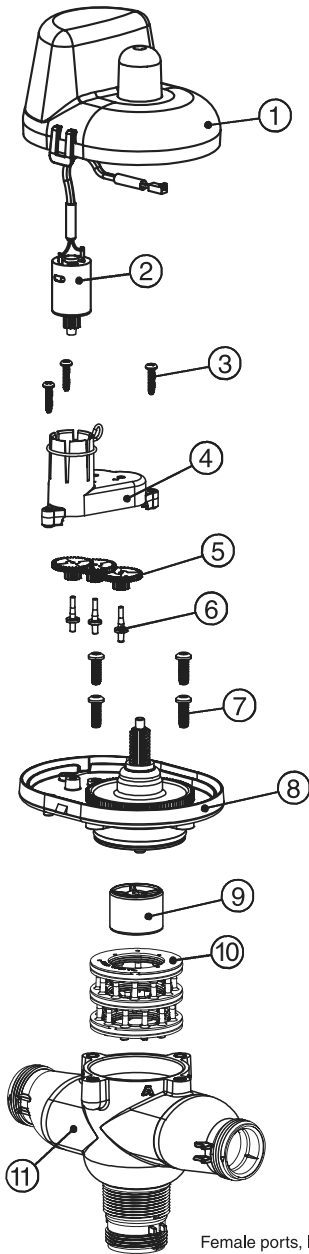

Quick Connect Nut Threads can be cut off to allow access to 1/2" NPT Threads. Deburr and clean edge after cutting.

NOTE: Teflon tape is required when using the 1/2" NPT Threads. Do not use pipe dope or other sealants on threads.

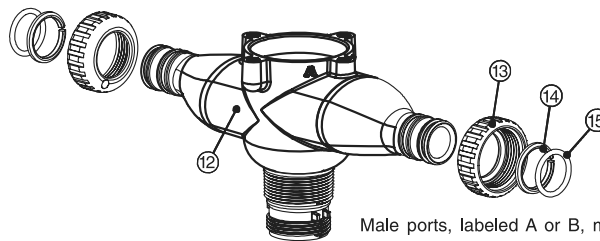

Female ports, labeled A or B, may be connected using Clack fitting packages. The motorized alternating valve unlabeled port accepts Clack fitting packages or may be removed to use 1/2" NPT threaded outlet.

Male ports, labeled A or B, may be connected directly to a Clack 1" or 1.25" control valve outlet or to a V3191-01 vertical bypass adapter assembly. The motorized alternating valve outlet accepts Clack fitting packages or may be removed to use 1/2" NPT threaded outlet.

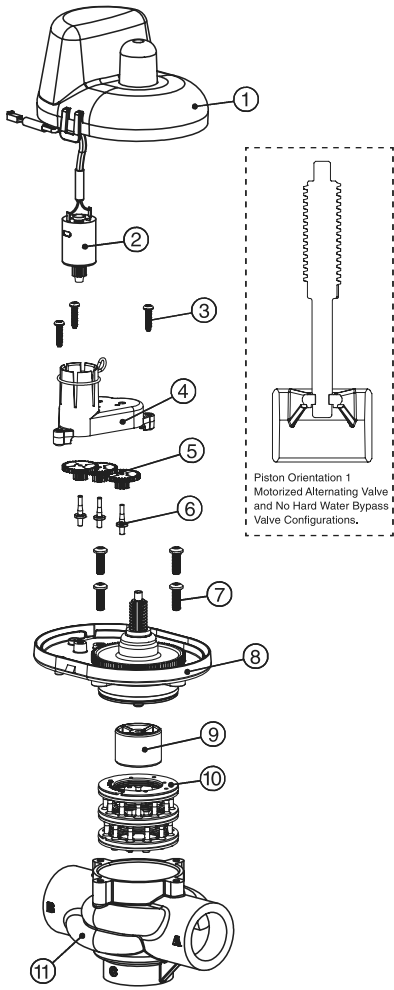

1.5" MAV PARTS			
DRAWING #	PART #	DESCRIPTION	QTY
1	V3073	MAV/NOWHBY Cover Assembly	1
2	V3476	WS Motor Assembly, 8ft	1
3	V3592	Screw #8-3/4, PHPN T-25 SS	1
4	V3262-01	WS1.5 & 2 ALT/2BY Reduction Gear Cover Assembly	1
5	V3110	WS1 Drive Reducing Gear 12x36	1
6	V3264	WS2 Bypass reduction Gear Axle	1
7	V3527	Screw 1/4-20 x 3/4, BHSCS SS	1
8	V3072	MAV/NOWHBY 1/1.25/1.5 Drive Assembly	1
9	V3506-01	MAV/NOHRD 1/1.25/1.5 Piston	1
10	V3074	MAV/NOHWBY 1/1.25/1.5 Stack Assembly	1
11	V3525-01	MAV Body 1/5 NPT	1
Not Shown	V3474	WS Alt MAV 1/1.25 Cord, 8ft Black	1
	V3071	Motor Alt Valve 1/5 NPT REV2 Assembly	1
	V3475	Option	1

2" MAV PARTS			
DRAWING #	PART #	DESCRIPTION	QTY
1	V3073	MAV/NOWHBY Cover Assembly	1
2	V3476	WS Motor Assembly, 8ft	1
3	V3592	Screw, #8 3/4, PHPN T-25 SS	1
4	V3262-01	WS1.5 & 2 Alt/2By Reduction Gear Cover Assembly	1
5	V3110	WS1 Drive Reducing Gear 12x36	1
6	V3264	WS2 Bypass Reduct Gear Axle	1
7	V3642	Screw 1/4-20 x 1-1/4, BHSCS SS	1
8	V3078	MAV/NOHWBY 2 Drive Assembly	1
9	V3634-01	MAV/NOHWBY 2 Piston	1
10	V3077	MAV/NOHWBY 2 Stack Assembly	1
11	V3633-01	WS2 MAV Body NPT	1
Not Shown	V3474	WS Alt Connection Cord, 8 ft Black	1
	V3076	Motor Alt Valve 2 NPT REV2 Assembly	1
	V3475	Option	1

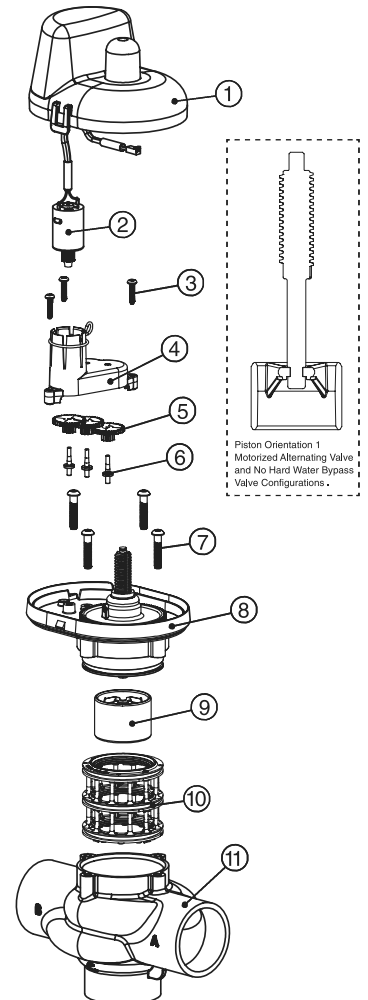

1" PLASTIC METER PARTS

DRAWING #	PART #	DESCRIPTION	QTY
1	V3003-02	WS1.5/2L/2H Meter Commercial Assembly	1
	V3221	WS Meter Assembly, 15 ft Cord (Includes items 2-4)	1
2	V3118-03	WS15/2 Turbine Assembly	1
3	V3105	O-Ring 215	1
4	V3501	WS15/2 Turbine Clip	1
5	V3755	WS1 Meter Housing	1
6	V3151	WS1 Nut QC	1
Not Shown	V3756	WS1 Flow Straightener	1
	V3039-15	Assembly	1

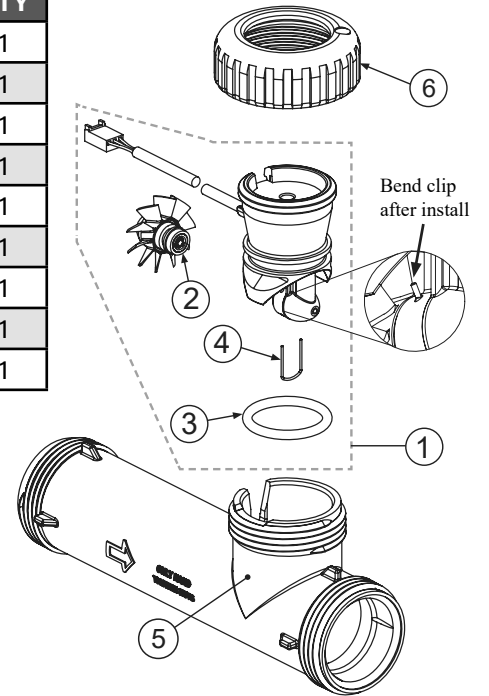

1.5", 2", 3" STAINLESS STEEL METER PARTS

DRAWING #	PART #	DESCRIPTION	QTY
1	V3003-02	WS1.5/2L/2H Meter Commercial Assembly	1
	V3221	WS Meter Assembly, 15 ft Cord (Includes items 2-4)	
2	V3118-03	WS15/2 Turbine Assembly	1
3	V3105	O-Ring 215	1
4	V3501	WS15/2 Turbine Clip	1
5	V3401-04	WS15 Meter Housing	1
	V3754-01	WS2 Meter Housing	1
	V3601-01	WS3 Meter Housing	1
6	V3632	Meter Retaining Clip	1
	V3040-15	WS1.5 Complete Meter Assembly	1
	V3094-15	WS2 Complete Meter Assembly	1
	V3095-15	WS3 Complete Meter Assembly	1

